

# **Dynamic Contouring Movers - Gen 2 & Controller**

Customer Product Manual

Part 7593729-03

Issued 02/26

**For parts and technical support, call the Industrial Coating  
Systems Customer Support Center at (800) 433-9319 or  
contact your local Nordson representative.**

This document is subject to change without notice.  
Check <http://emanuals.nordson.com> for the latest version.

---



NORDSON DEUTSCHLAND GMBH

---

**Contact Us**

Nordson Corporation welcomes requests for information, comments, and inquiries about its products. General information about Nordson can be found on the Internet using the following address:  
<http://www.nordson.com>.

Address all correspondence to:

Nordson GmbH  
Heinrich Hertz Strasse 42  
40699 Erkrath,  
Germany

**Notice**

This is a Nordson Corporation publication which is protected by copyright. Original copyright date 2020. No part of this document may be photocopied, reproduced, or translated to another language without the prior written consent of Nordson Corporation. The information contained in this publication is subject to change without notice.

**Trademarks**

Nordson and the Nordson logo are registered trademarks of Nordson Corporation.

All other trademarks are the property of their respective owners.





## EC DECLARATION OF CONFORMITY

ACCORDING TO CE DIRECTIVE 2006/42/ EC ANNEX II 1A

**DESCRIPTION:** Dynamic Contouring Mover (DCM) for powder application

**FAMILY/MODELS:** DCM All variants (6ft-Right/Left, 5ft-Right/Left)  
p/n 7035724, 7035725, 7035726, 7035727

**APPLICABLE DIRECTIVES & STANDARDS USED TO VERIFY COMPLIANCE:**

Directive 2006/42/EC (Machinery)  
2014/34/EU Explosive Atmosphere  
EN 60204-1 "Safety of Machinery - Electrical equipment of machines"  
EN ISO 12100 "Safety of machinery - Basic concepts, general principles for design"

**MARKING OF PRODUCT:** 

The equipment delivered is generally intended to be part of a powder coating system and can be operated on its own or in conjunction with other equipment.

In order to be in full compliance with the CE machinery directive and its amendments, the customer is obliged to respect the applicable regulations for his powder coating system upon incorporation of the equipment in the powder coating plant and before starting operation.

We hereby declare that the product specified conforms to the directives and standards described above and that it has been provided with a CE label. Provided the product is installed and operated in line with the Nordson manuals, its operation is safe.

Name and address of Nordson authorized person



Kai Flockenhaus  
Manager Procurement & Process,  
ICS Europe (Industrial Coating Systems)  
Nordson Deutschland GmbH  
40699 Erkrath, Heinrich-Hertz-Strasse 42

Date: 12/05/2023

x

<b>Safety</b> .....	<b>1</b>
<b>Qualified Personnel</b> .....	<b>1</b>
<b>Intended Use</b> .....	<b>1</b>
<b>Regulations and Approvals</b> .....	<b>1</b>
<b>Personal Safety</b> .....	<b>2</b>
<b>Fire Safety</b> .....	<b>2</b>
<b>Grounding</b> .....	<b>3</b>
<b>Action in the Event of a Malfunction</b> .....	<b>3</b>
<b>Disposal</b> .....	<b>3</b>
<b>Description – DCM (Dynamic Contouring Mover)</b> .....	<b>4</b>
<b>Function</b> .....	<b>5</b>
<b>Installation</b> .....	<b>5</b>
<b>Transport</b> .....	<b>6</b>
<b>Unpacking</b> .....	<b>6</b>
<b>Storage</b> .....	<b>6</b>
<b>Preparing for Installation</b> .....	<b>6</b>
<b>Installation Concept and Connection Points</b> .....	<b>7</b>
<b>Installing the DCM onto the Reciprocator</b> .....	<b>8</b>
<b>Home Position Setting</b> .....	<b>10</b>
<b>Grounding</b> .....	<b>11</b>
<b>Removing the Encore Automatic Gun</b> .....	<b>12</b>
<b>Maintenance</b> .....	<b>13</b>
<b>Maintenance Table</b> .....	<b>13</b>
<b>Replacing the Linear Bearing Bushing</b> .....	<b>14</b>
<b>Troubleshooting</b> .....	<b>18</b>
<b>Parts</b> .....	<b>19</b>
<b>System Layout Schematic – with Powder Pilot<sup>®</sup> 4.X</b> .....	<b>21</b>
<b>System Layout Schematic – with iControl 2 or Engage</b> ....	<b>22</b>
<b>Servomotor Electrical Data</b> .....	<b>23</b>
<b>Technical Data</b> .....	<b>24</b>
Dimensions and Weights .....	<b>24</b>
<b>DCM Controller</b> .....	<b>27</b>
<b>Description</b> .....	<b>27</b>
<b>Installation</b> .....	<b>28</b>
System Configuration .....	<b>28</b>
DCM Settings .....	<b>30</b>
Scanner Settings .....	<b>34</b>
Scanner Status .....	<b>37</b>
Horizontal Distances .....	<b>38</b>
Vertical Zone Definition .....	<b>39</b>
Reciprocator Settings .....	<b>40</b>
Booth Settings .....	<b>41</b>
DCM Homing .....	<b>42</b>
User Administration – Customer Supervisor .....	<b>43</b>
<b>Operation</b> .....	<b>44</b>

System Start Up .....	44
Global Navigation Bar .....	45
Main Start Screen .....	46
Manual Program Load Control .....	48
Reciprocator Control .....	49
DCM Control .....	51
Program Editing .....	53
System Alarm List .....	56
<b>Stand Alone System Colour Change .....</b>	<b>57</b>
<b>Maintenance .....</b>	<b>58</b>
<b>Repair .....</b>	<b>58</b>
<b>Troubleshooting .....</b>	<b>59</b>
<b>Wiring Diagram .....</b>	<b>61</b>
<b>Appendix A – System Dimensions .....</b>	<b>62</b>
Scanners to Booth .....	62
Scanners to DCM's .....	63
Zones .....	64
Vertical Adjustments .....	65
Horizontal Adjustments .....	66
Right Side Valid Scanning Zone .....	67
Left Side Valid Scanning Zone .....	68

## Safety

Read and follow these safety instructions. Task- and equipment-specific warnings, cautions, and instructions are included in equipment documentation where appropriate.

Make sure all equipment documentation, including these instructions, is accessible to all persons operating or servicing equipment.

## Qualified Personnel

Equipment owners are responsible for making sure that Nordson equipment is installed, operated, and serviced by qualified personnel. Qualified personnel are those employees or contractors who are trained to safely perform their assigned tasks. They are familiar with all relevant safety rules and regulations and are physically capable of performing their assigned tasks.

## Intended Use



**CAUTION:** Use of Nordson equipment in ways other than those described in the documentation supplied with the equipment may result in injury to persons or damage to property.

Some examples of unintended use of equipment include

- using incompatible materials
- making unauthorized modifications
- removing or bypassing safety guards or interlocks
- using incompatible or damaged parts
- using unapproved auxiliary equipment
- operating equipment in excess of maximum ratings

## Regulations and Approvals



**WARNING:** Make sure all equipment is rated and approved for the environment in which it is used. Any approvals obtained for Nordson equipment will be voided if instructions for installation, operation, and service are not followed.

All phases of equipment installation must comply with all local codes.

## Personal Safety

To prevent injury, follow these instructions.

- Do not operate or service equipment unless you are qualified.
- Do not operate equipment unless safety guards, doors, or covers are intact and automatic interlocks are operating properly. Do not bypass or disarm any safety devices.
- Keep clear of moving equipment. Before adjusting or servicing any moving equipment, shut off the power supply and wait until the equipment comes to a complete stop. Lock out power and secure the equipment to prevent unexpected movement.
- Relieve (bleed off) pneumatic pressure before adjusting or servicing pressurized systems or components. Disconnect, lock out, and tag switches before servicing electrical equipment.
- Obtain and read Safety Data Sheets (SDS) for all materials used. Follow the manufacturer's instructions for safe handling and use of materials, and use recommended personal protection devices.
- To prevent injury, be aware of less-obvious dangers in the workplace that often cannot be completely eliminated, such as hot surfaces, sharp edges, energized electrical circuits, and moving parts that cannot be enclosed or otherwise guarded for practical reasons.
- Do not use the air blow gun to clean your body. Compressed air can pierce the skin and if directed towards the face it could cause a severe eye injury.

## Fire Safety

To avoid a fire or explosion, follow these instructions.

- Do not smoke, weld, grind, or use open flames where flammable materials are being used or stored.
- Provide adequate ventilation to prevent dangerous concentrations of volatile materials or vapors. Refer to local codes or your material SDS for guidance.
- Do not disconnect live electrical circuits while working with flammable materials. Shut off power at a disconnect switch first to prevent sparking.
- Know where emergency stop buttons, shutoff valves, and fire extinguishers are located. If a fire starts in a spray booth, immediately shut off the spray system and exhaust fans.
- Clean, maintain, test, and repair equipment according to the instructions in your equipment documentation.
- Use only replacement parts that are designed for use with original equipment. Contact your Nordson representative for parts information and advice.

## Grounding



**WARNING:** Operating faulty electrostatic equipment is hazardous and can cause electrocution, fire, or explosion. Make resistance checks part of your periodic maintenance program. If you receive even a slight electrical shock or notice static sparking or arcing, shut down all electrical or electrostatic equipment immediately. Do not restart the equipment until the problem has been identified and corrected.

Grounding inside and around the booth openings must comply with EN50050-2, EN50177, EN16985, latest conditions.

- All electrically conductive objects in the spray areas shall be electrically connected to ground with a resistance of not more than 1 ohm when measured with an appropriate instrument.
- Equipment to be grounded includes, but is not limited to, the floor of the spray area, operator working area platforms, hoppers, photoeye supports, and blow-off nozzles. Personnel working in the spray area must be grounded.
- There is a possible ignition potential from the charged human body. Personnel standing on a painted surface, such as an operator platform, or wearing non-conductive shoes, are not grounded. Personnel must wear shoes with conductive soles or use a ground strap to maintain a connection to ground when working with or around electrostatic equipment.
- Operators must maintain skin-to-handle contact between their hand and the gun handle to prevent shocks while operating manual electrostatic spray guns. If gloves must be worn, cut away the palm or fingers, wear electrically conductive gloves, or wear a grounding strap connected to the gun handle or other true earth ground.
- After servicing equipment, reconnect all disconnected equipment, ground cables and wires.

## Action in the Event of a Malfunction

If a system or any equipment in a system malfunctions, shut off the system immediately and perform the following steps:

- Disconnect and lock out electrical power. Close pneumatic shutoff valves and relieve pressures.
- Identify the reason for the malfunction and correct it before restarting the equipment.

## Disposal

Dispose of equipment and materials used in operation and servicing according to local codes.

## Description – DCM (Dynamic Contouring Mover)



Figure 1 **Dynamic Contouring Mover**

The Nordson DCM is designed to improve the coating operation by automatically adjusting the position of each automatic powder spray gun individually according to the product's geometry.

Using a heavy duty reciprocating arm, each DCM moves in a linear horizontal motion, to ensure it follows the profile of the product for optimal coating. This enables excellent coating for all products including those with complex contours.

Each DCM is equipped with a Nordson Encore Automatic Gun (Tube Mount version). 5, 6 and 8 foot gun options are available.

## Function

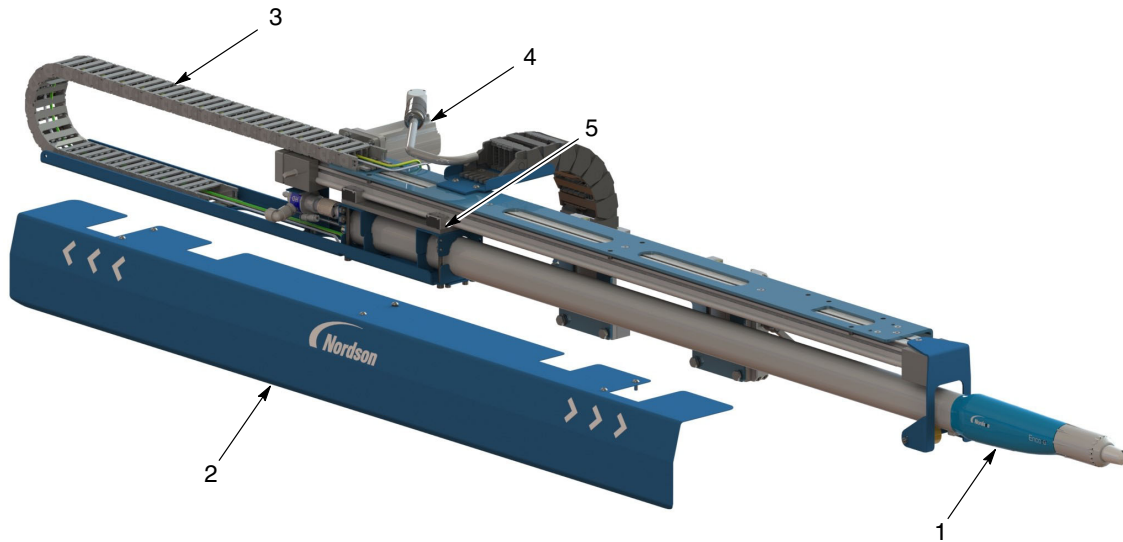

Figure 2 Identification of DCM Components

Item	Component	Function
1	Encore Automatic Gun	Charges the powder electrostatically and applies it to the product
2	Cover	Protective shroud to cover the mechanics of the DCM
3	Energy Chain	Supports the cable and tubing supply to the gun
4	Motor Assembly	Drives the gun and reciprocates along the horizontal plane
5	Carriage	Mounting point for the automatic gun

See Figure 2

The Encore automatic powder spray gun is mounted to the carriage of the DCM which enables horizontal reciprocation with its drive belt structure. Inductive sensors are fitted to determine the start and stop positions. All electrical connections are installed at the rear of the unit, they are supported and guided using a flexible energy chain.

The geometry of the product to be coated is obtained using 2D laser scanners which transmit the data to the Nordson Powder Pilot control system. This control system defines the movement required for each individual gun and precisely moves them using a servo motor and the latest technology drives.

## Installation



**WARNING:** Allow only qualified personnel to perform the following tasks. Follow the safety instructions in this document and all other related documentation.

When the DCM is mounted onto the vertical reciprocating device, it is essential to define the area required for all machines to move freely and avoid collision. According to Norm EN13857, regarding the safety of machinery and safe distances in hazardous zones.

All electrical connections must be made by a qualified electrician.

All fasteners and clamps must be securely tightened before operating the DCM.

**NOTE:** Pneumatic (including pressure and quality) and electrical supplies must be in accordance with the system drawings supplied by Nordson.

## Transport

Transport the unit so as to avoid damage. Use suitable packaging materials. Protect the unit from humidity, large temperature fluctuations (condensation), dust and vibrations.

## Unpacking

Unpack the unit carefully to avoid damage. Inspect for any damage caused during transport. Save packing materials for possible later use, or otherwise dispose of properly according to local regulations.

## Storage

Use suitable packaging materials. Protect the unit from humidity, large temperature fluctuations (condensation), dust and vibrations.

## Preparing for Installation

**NOTE:** The Nordson DCM units are delivered fully assembled and only require the Encore automatic gun to be mounted. Ensure that all necessary brackets are available ready to mount the DCM.

# Installation Concept and Connection Points

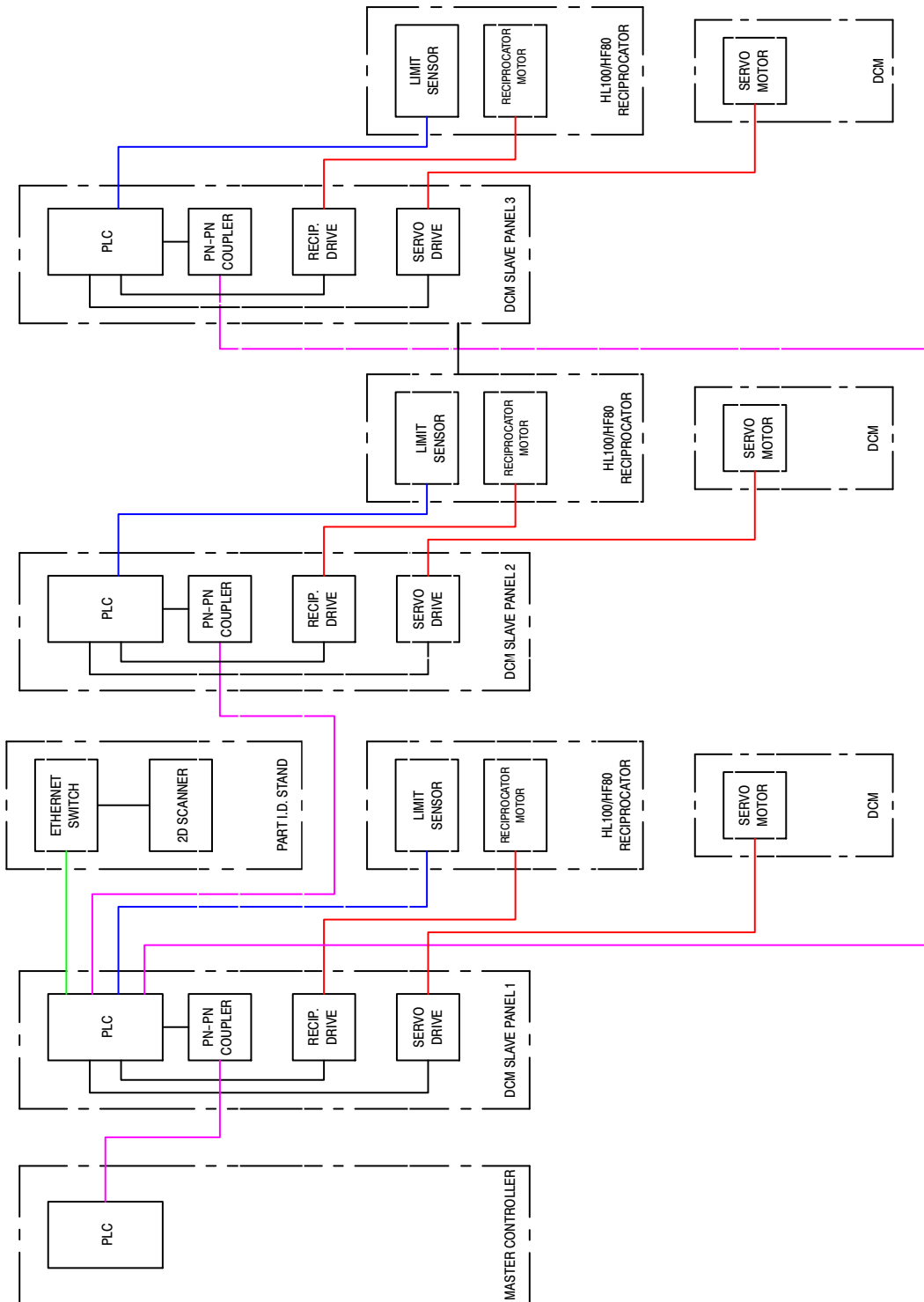

Figure 3 Layout Showing Installation Concept and Connection Points

The DCM's are connected to the coating system as displayed in the above diagram. This diagram shows the minimum requirements needed to run the DCM.

## Installing the DCM onto the Reciprocator

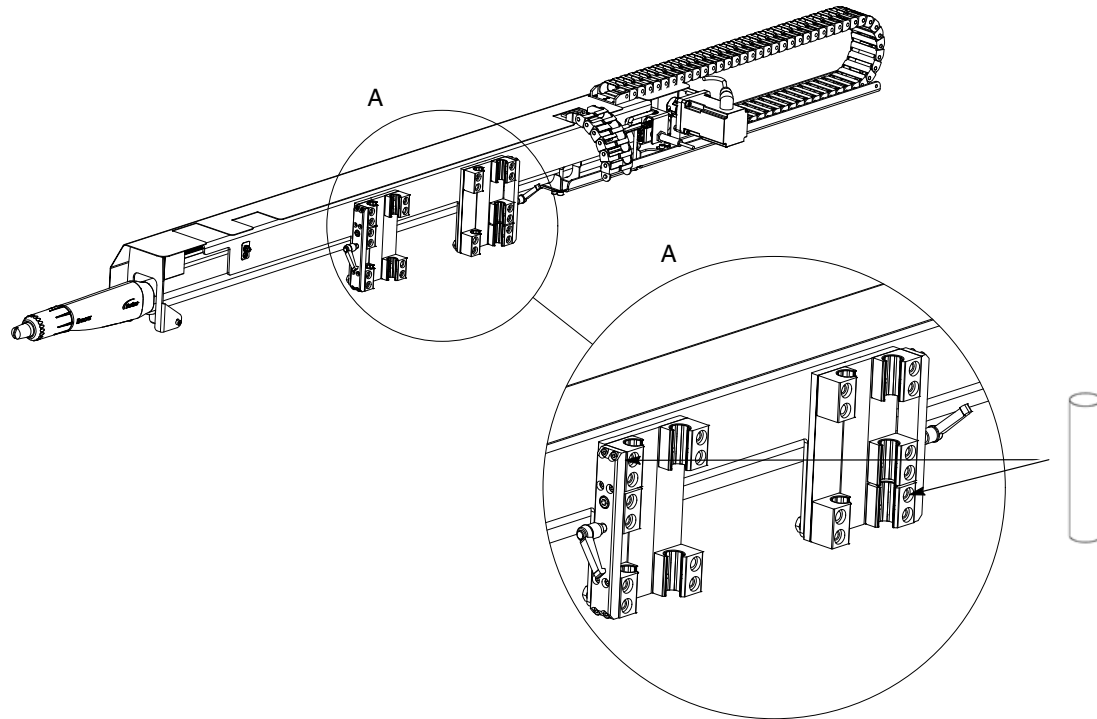

Figure 4 **DCM Mounting Brackets**

1. Loosen the clamps (A) on the back side of the DCM. Do not remove the support bolt as this is holding the sliding bearing in place. Then fit the installation guide rods.

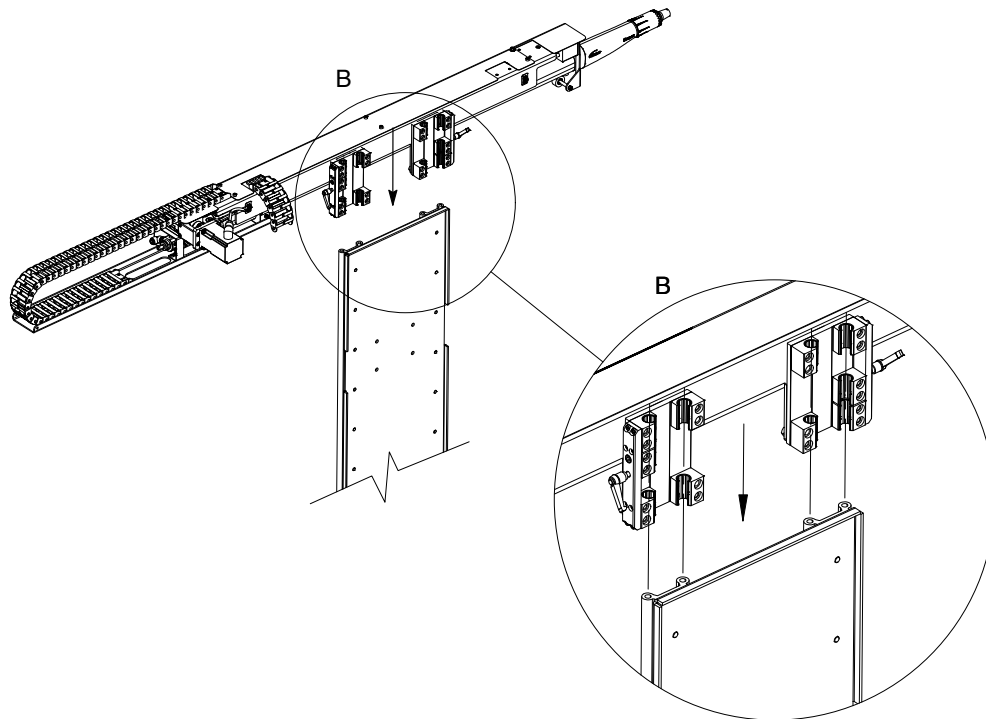

Figure 5 **Attaching the DCM**

2. Use the installation guide rods to cover the sharp edges of the mounting rail. Slide the DCM into the bracket as shown above.

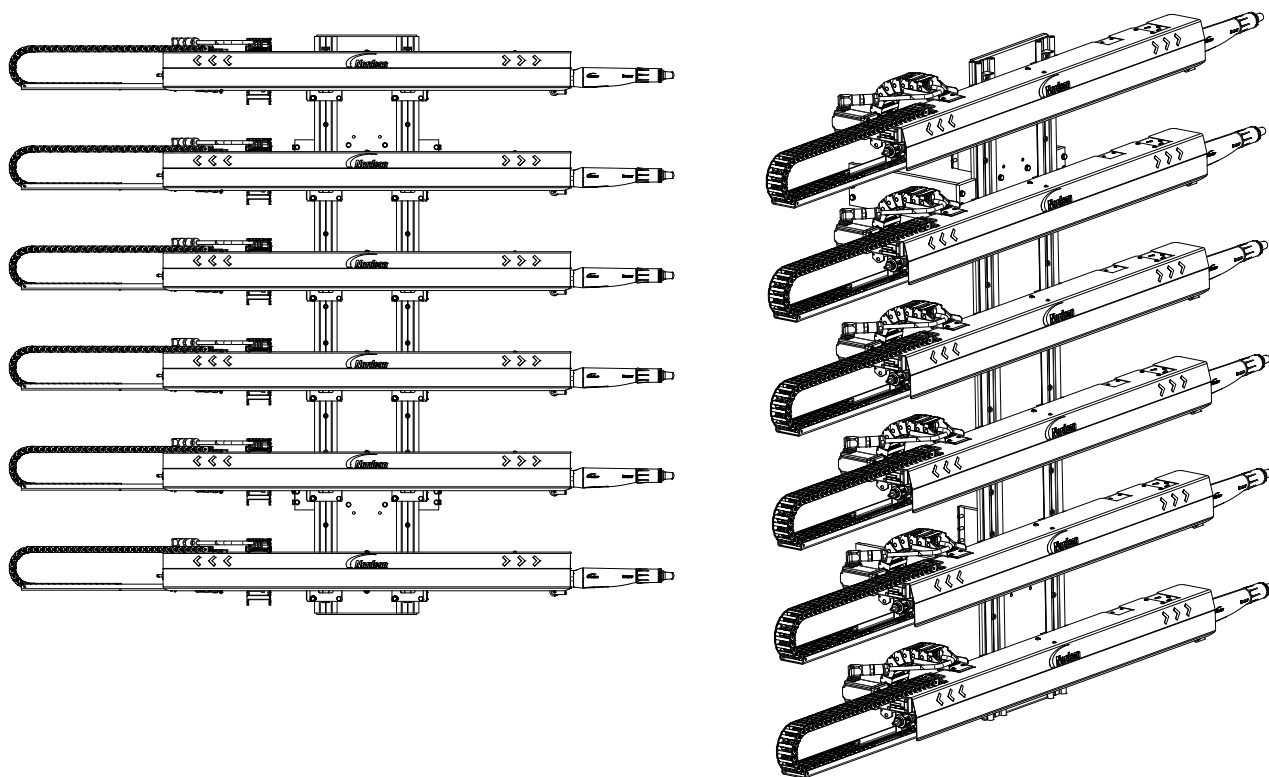

Figure 6 DCM Mounting

3. Install all DCM's onto the rail. Tighten the clamps to secure them in position.

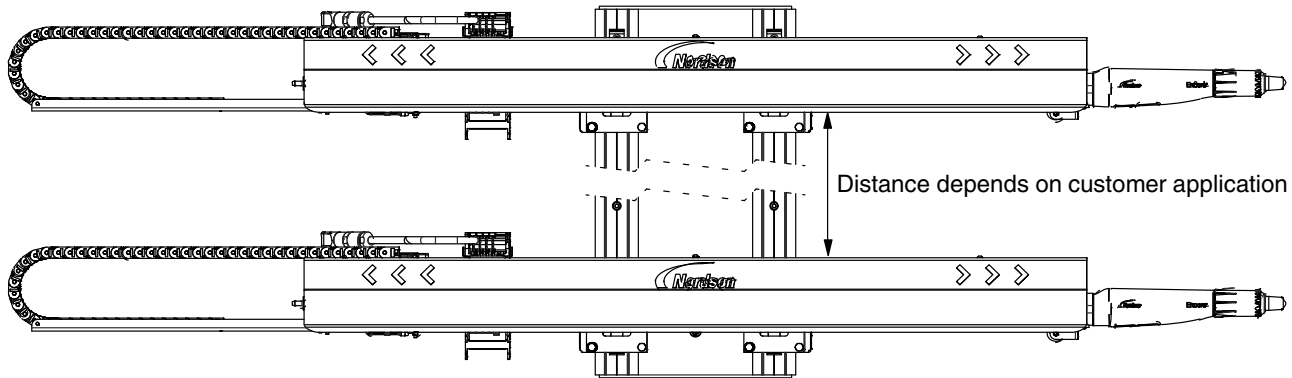

Figure 7 Positioning the DCM

4. Set the limit sensors and mechanical hard stop on the reciprocator to the required position.

**NOTE:** The counterweights inside the reciprocator will need adjusting to accommodate the additional weight. For the installation guide of the counterbalance weights, please see the relevant technical manual on the Nordson eManuals website – [www.emanuals.nordson.com/finishing](http://www.emanuals.nordson.com/finishing) (Powder-Europe)

## Home Position Setting

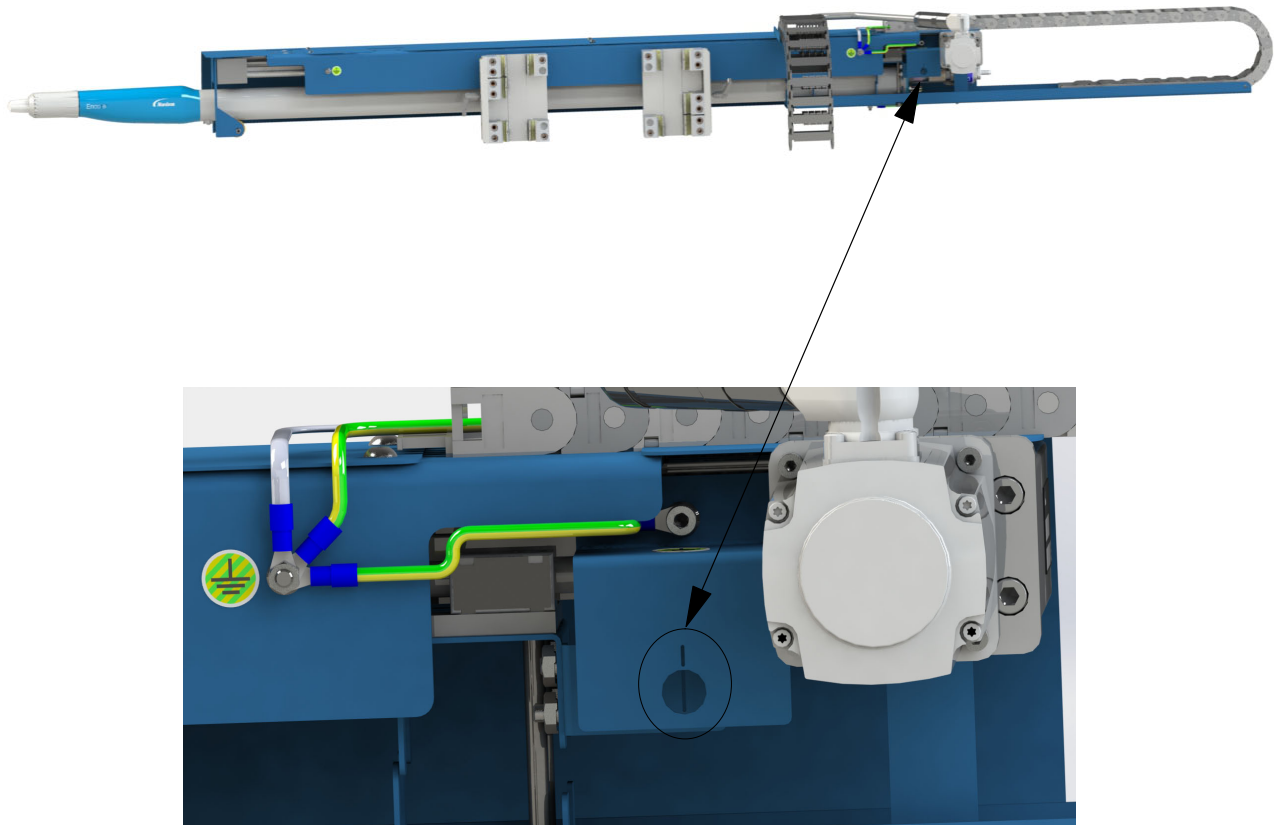

Figure 8 Positioning the DCM Home Position

Ensure DCM servo drive control power is switched Off, on the DCM settings screen at the HMI.

Manually move the gun carriage until the 2 lines in the image above, are aligned.

Then touch the Home button for this DCM and ensure the Current Position value shows 0 mm.

**NOTE:** Refer to system Operator Card/Manual for detailed instructions of the HMI.

# Grounding

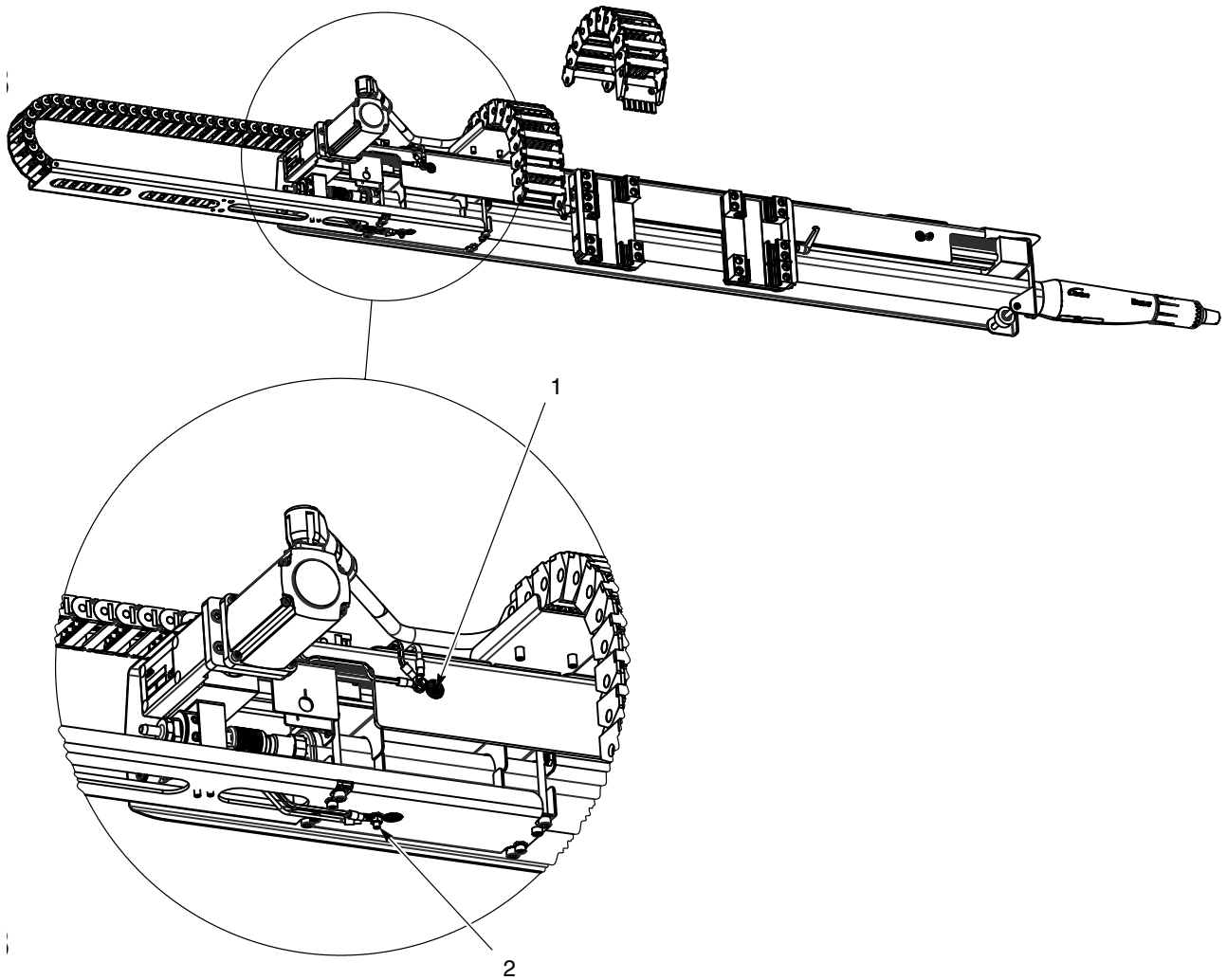

Figure 9 **Grounding Points**

It is essential that the DCM is always properly grounded. Points 1 and 2 must be connected with a ground cable via the energy chain. Point 1 must also be connected to the ground point on the reciprocator.

## Removing the Encore Automatic Gun

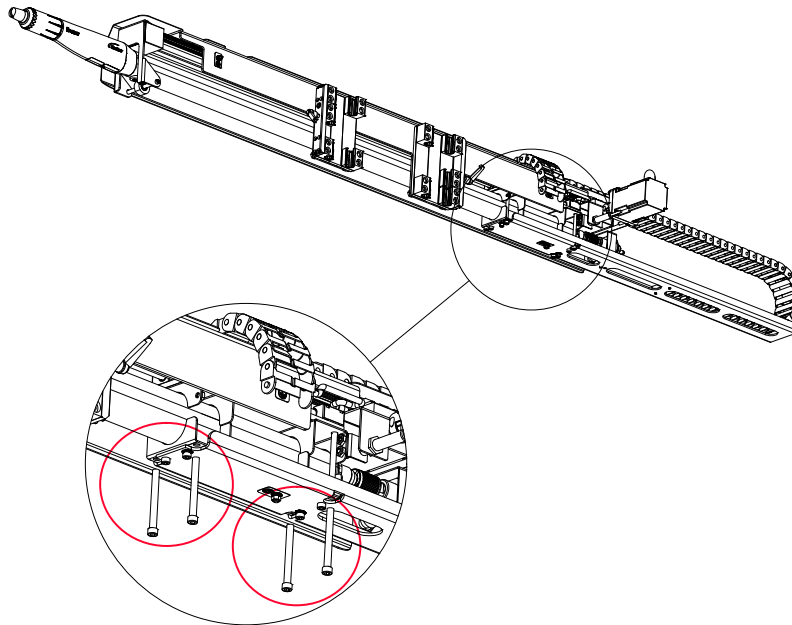

Figure 10 Fixing Points of Encore Automatic Gun

1. Drive the DCM to its starting position.
2. Turn off the system power and isolate.
3. Unplug all cables and hoses then disconnect the grounding points.
4. Loosen the 4 screws indicated above.



**CAUTION:** Do not remove the screws completely as this may cause the gun or brackets to fall.

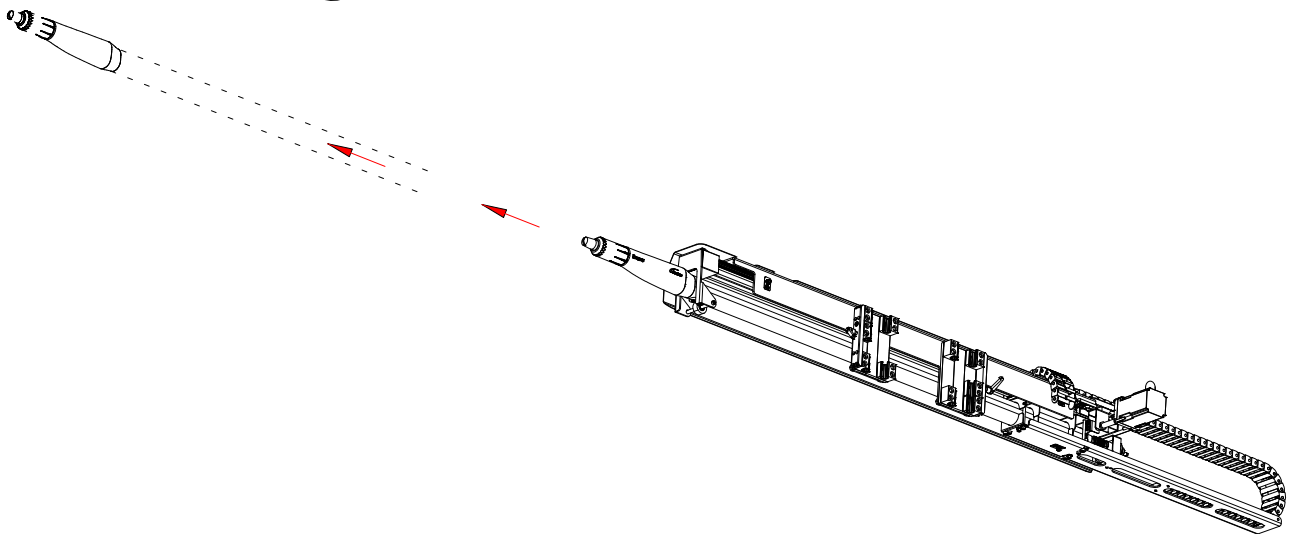

Figure 11 Automatic Gun Removal

5. The gun is now completely free to slide out from the front of the DCM.
6. To reinstall the gun or a replacement, reverse steps 1 - 5

## Maintenance



**WARNING:** Breathing in certain airborne dusts (including finishing powders) may be hazardous to health. Ask the powder manufacturer for a Material Safety Data Sheet (MSDS) for information. Use appropriate respiratory protection. Always disconnect the power and wait until the motor has cooled, before removing covers and working on the device.



**CAUTION:** It is important to follow the specific maintenance instructions of each product.

## Maintenance Table

Description	Operator	Action	Daily	Weekly	Monthly	Quarterly	6 Monthly	Yearly	AR
Clean and remove powder from the automatic spray gun	TO	Use a clean lint free cloth to wipe the powder	X						
Clean and remove powder from the linear axis	TO	Use a clean, lint free cloth to wipe the powder	X						
Clean and remove powder from the drive motor	TO	Use a clean, lint free cloth to wipe the powder	X						
Clean and remove powder from the belts and cables	TO	Use a clean, lint free cloth to wipe the powder		X					
Re-adjust / tighten all clamps on the reciprocator	TO	For tightening turn the grip handle clockwise			X				
Check all electrical power cables	ST	Visual inspection			X				
Check all powder hose connections	ST	Visual inspection			X				
Check all gun cables	ST	Visual inspection			X				
Check the complete system and replace worn or damaged parts	ND or ST	Visual inspection					X		
Replace the sliding bearings bushing	ND or ST	Refer to the instructions that follow							X

ND = Nordson Technician TO = Trained Operator ST = Skilled/Trained Technician

## Replacing the Linear Bearing Bushing

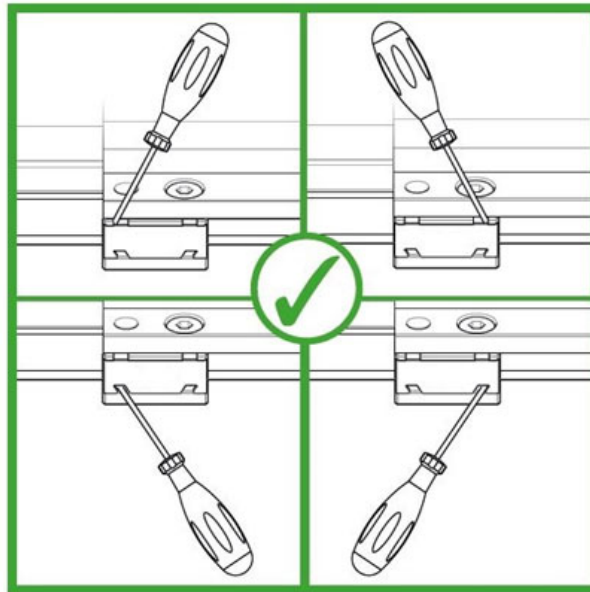

Figure 12 **Linear Bearing Bushing Removal - 1**

1. Turn off the system and isolate
2. Open the side cover of the bearing with a screwdriver

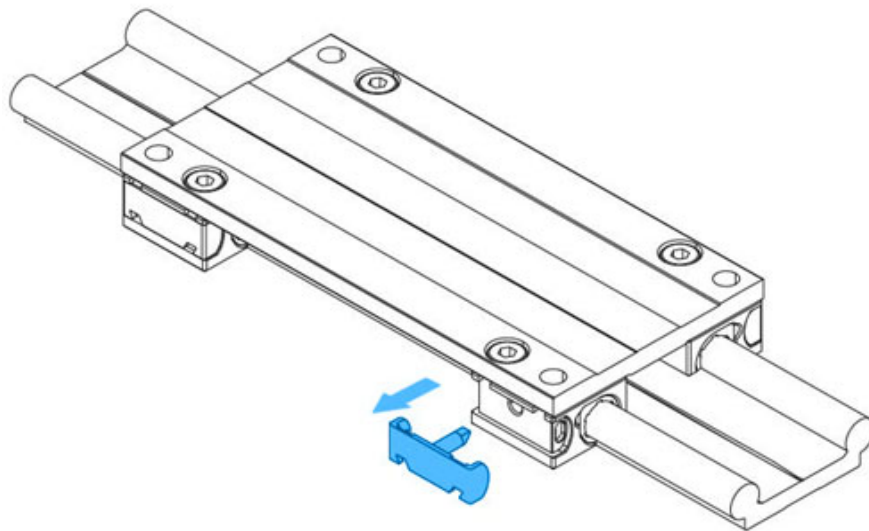

Figure 13 **Linear Bearing Bushing Removal - 2**

3. Remove the side cover (1) of the bearing

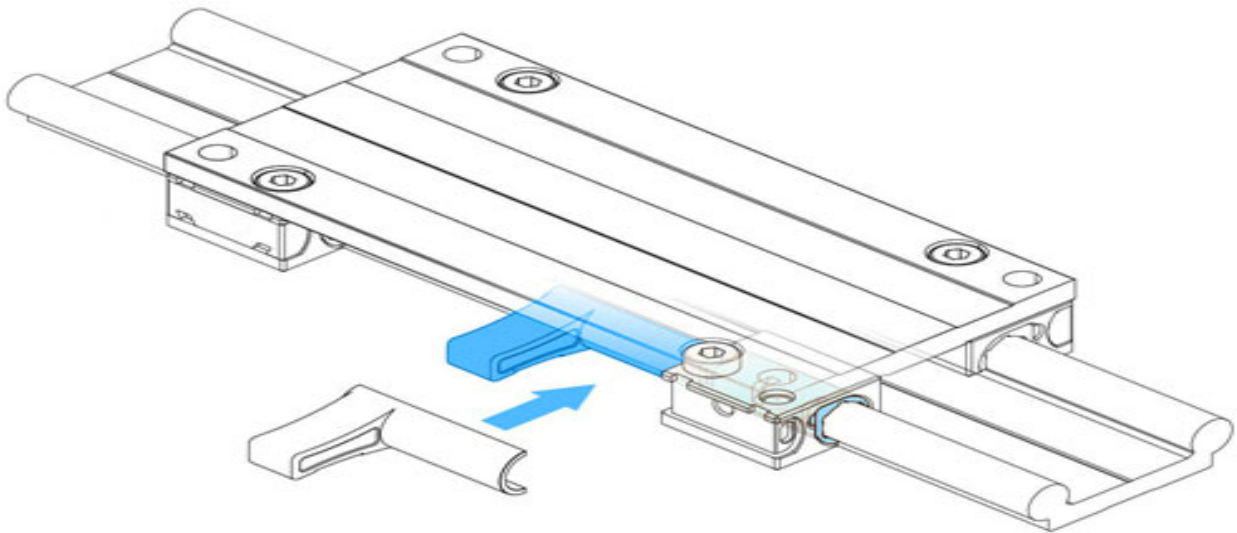

Figure 14 **Linear Bearing Bushing Removal - 3**

4. Place the bushing removal tool (2) next to the bearing on the rail

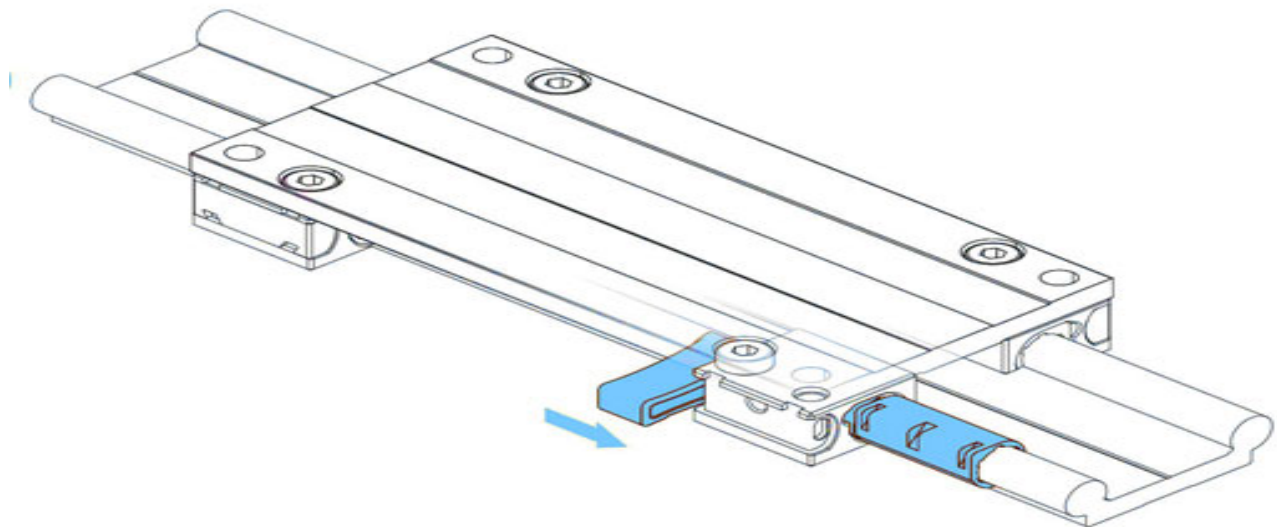

Figure 15 **Linear Bearing Bushing Removal - 4**

5. Push the removal tool in the direction of the arrow shown until the bushing is completely out of the housing

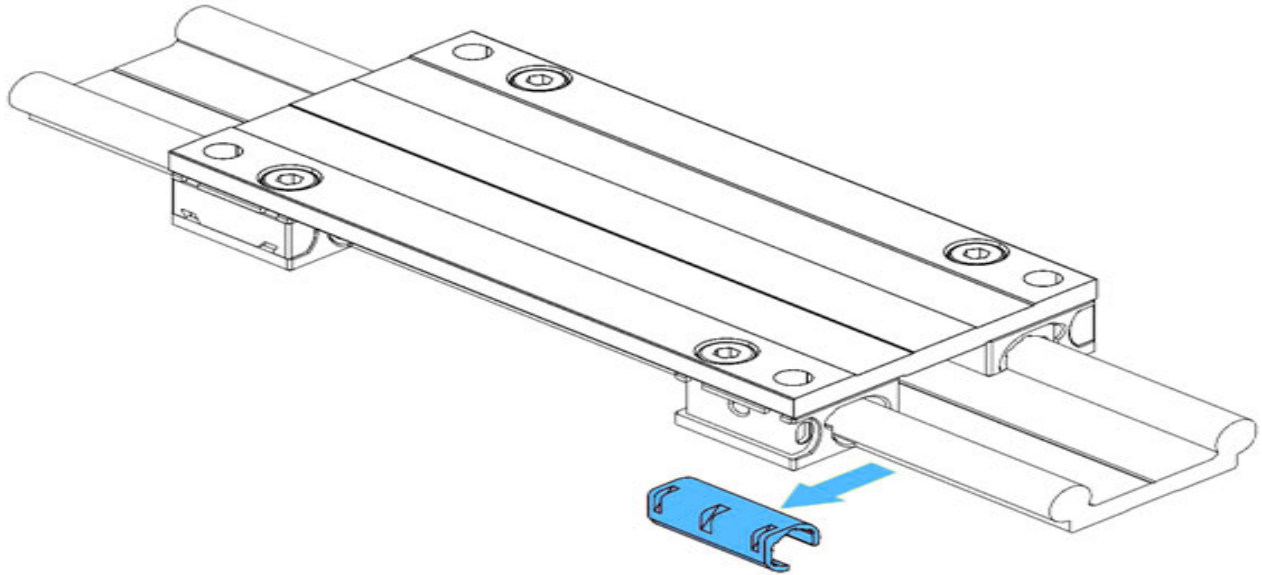

Figure 16 **Linear Bearing Bushing Removal - 5**

6. Unclip the bushing (3) and dispose of it

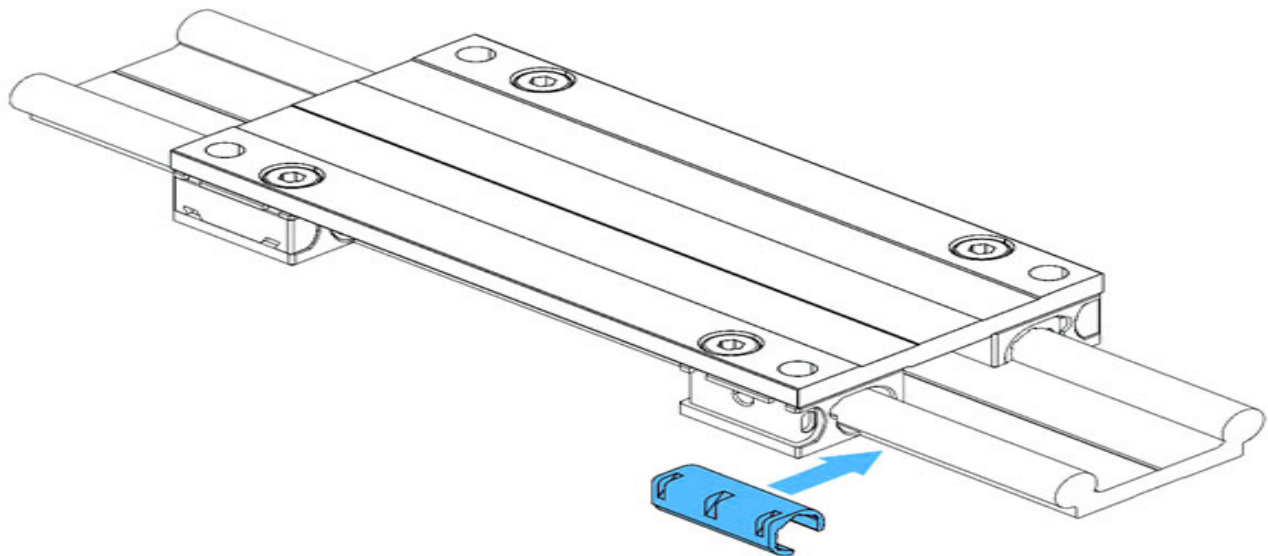

Figure 17 **Linear Bearing Bushing Removal - 6**

7. Fit the new bushing onto the rail

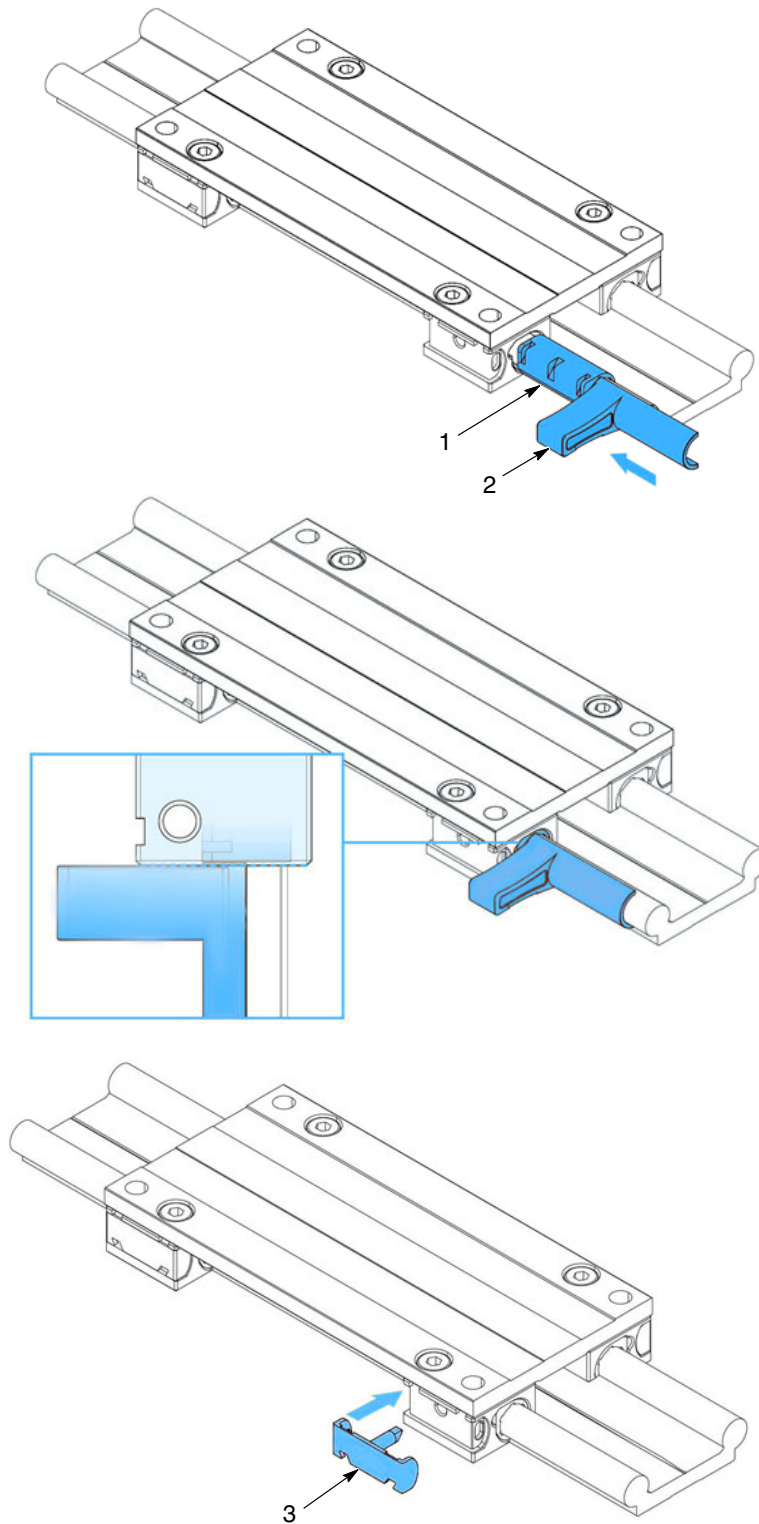

Figure 18 Linear Bearing Bushing Removal - 7

8. Push the new bushing (1) inside the bearing housing until the tool (2) stops at the bearing housing, as shown above. Then refit the side cover (3) of the bearing.

## Troubleshooting



**WARNING:** Allow only qualified personnel to perform the following tasks. Follow the safety instructions in this document and all other related documentation.

**NOTE:** A fault can occur for several reasons. It is advisable to check all possible causes for a given fault. Obvious causes of malfunction such as broken wires, missing fasteners etc., should be noted during visual inspections and corrected immediately. These troubleshooting procedures cover only the most common problems. If you cannot solve a problem, contact your Nordson representative.

Problem	Possible Cause	Corrective Action
1. Axis does not move	Connection cables are not connected or are defective	Inspect the cables. Ensure they are correctly connected or replace if they are defective
	Linear mover is blocked or jammed	Inspect the mover. Remove anything that could be blocking it and repair or replace if necessary
	Defective drive motor	Replace the drive motor unit
2. Excessive noise	Toothed belt loose and scraping	Inspect the toothed belt. Re-tension or replace as necessary
	Drive motor issue	Repair or replace as necessary
3. The DCM is vibrating while moving	The carriage is not correctly mounted on the linear axis	Inspect and repair as required

## Parts

To order parts, call the Nordson Industrial Coating Systems Customer Support Center at (800) 433-9319 or contact your local Nordson representative.

See Figure 19 - page 20

Item	Part	Description	Quantity	Note
-	7035724	ASSEMBLY, DCM HD/VT, GEN2, 5FT, RH	-	A
-	7035725	ASSEMBLY, DCM HD/VT, GEN2, 5FT, LH	-	A
-	7035726	ASSEMBLY, DCM HD/VT, GEN2, 6FT, RH	-	A
-	7035727	ASSEMBLY, DCM HD/VT, GEN2, 6FT, LH	-	A
-	7035800	ASSEMBLY, DCM HD/VT, GEN2, 8FT, RH	1	A
-	7035801	ASSEMBLY, DCM HD/VT, GEN2, 8FT, LH	1	A
1	7035289	KIT,DCM,APPLICATOR WHEEL GUIDE	1	
-	7035279	KIT, DCM,SLIDE BEARINGS,W/TOOL	1	B, C
-	-----	Bushing Removal Tool	1	B, C
-	-----	Slider Bearing Side Cover	1	B, C
2	7035700	MOTOR, DCM, GEN 2, 0.2 KW, MULTITURN	1	
3	7035701	CABLE, MOTOR, GEN 2, DCM, 20M, M23	1	
4	7035286	COUPLING,DCM,MOTOR	1	
NS	7035702	DRIVE, MOTOR, DCM, GEN 2	1	D
<p>NOTE A: The DCM units are handed, Left and Right. Ensure you order the correct unit - L or R            B: Comes in kit part number 7035279            C: See pages 14 to 17            D: Located in main control panel</p> <p>AR: As Required            NS: Not Shown</p>				

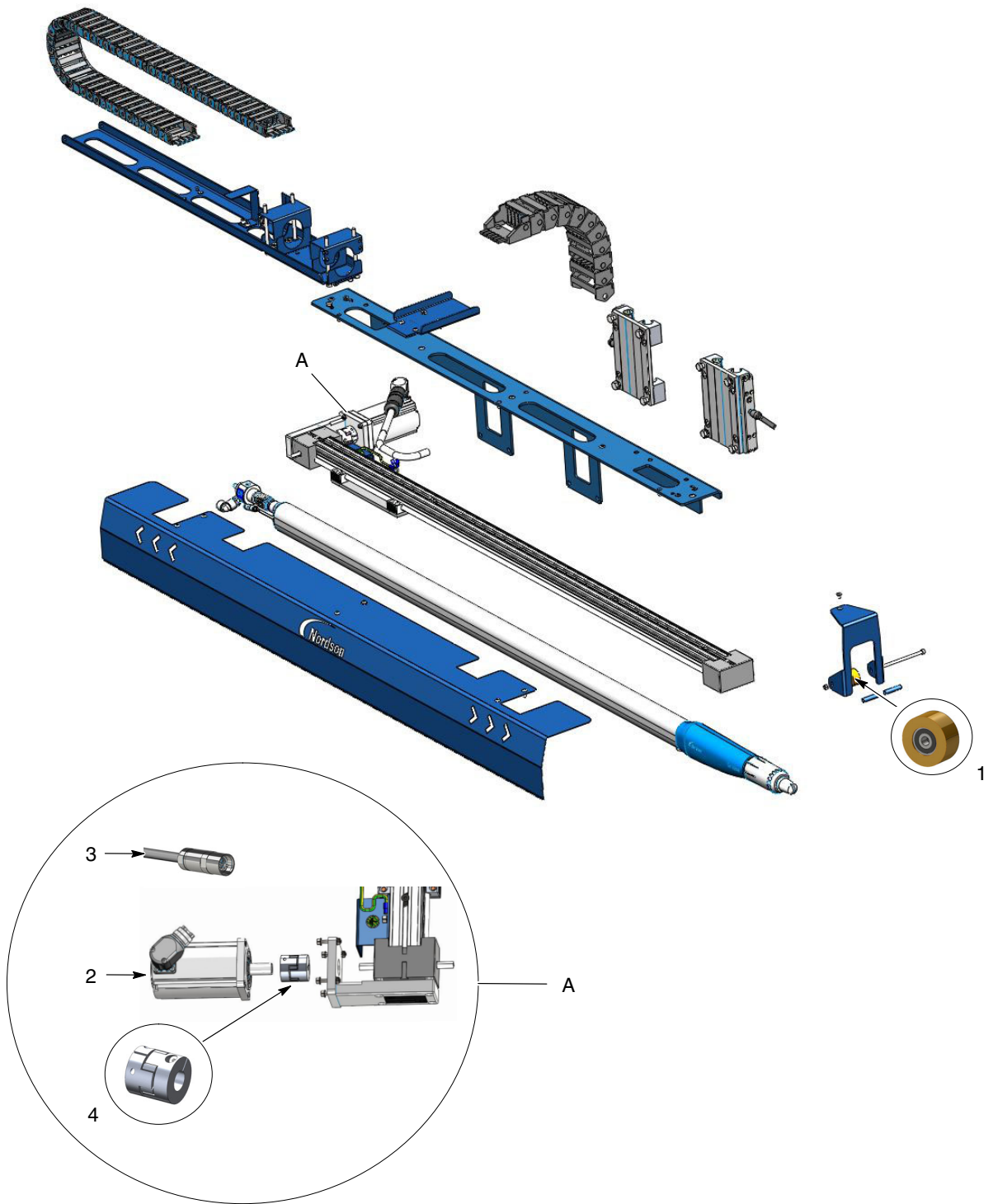

Figure 19 Spare Parts Identification Images

# System Layout Schematic – with Powder Pilot™ 4.X

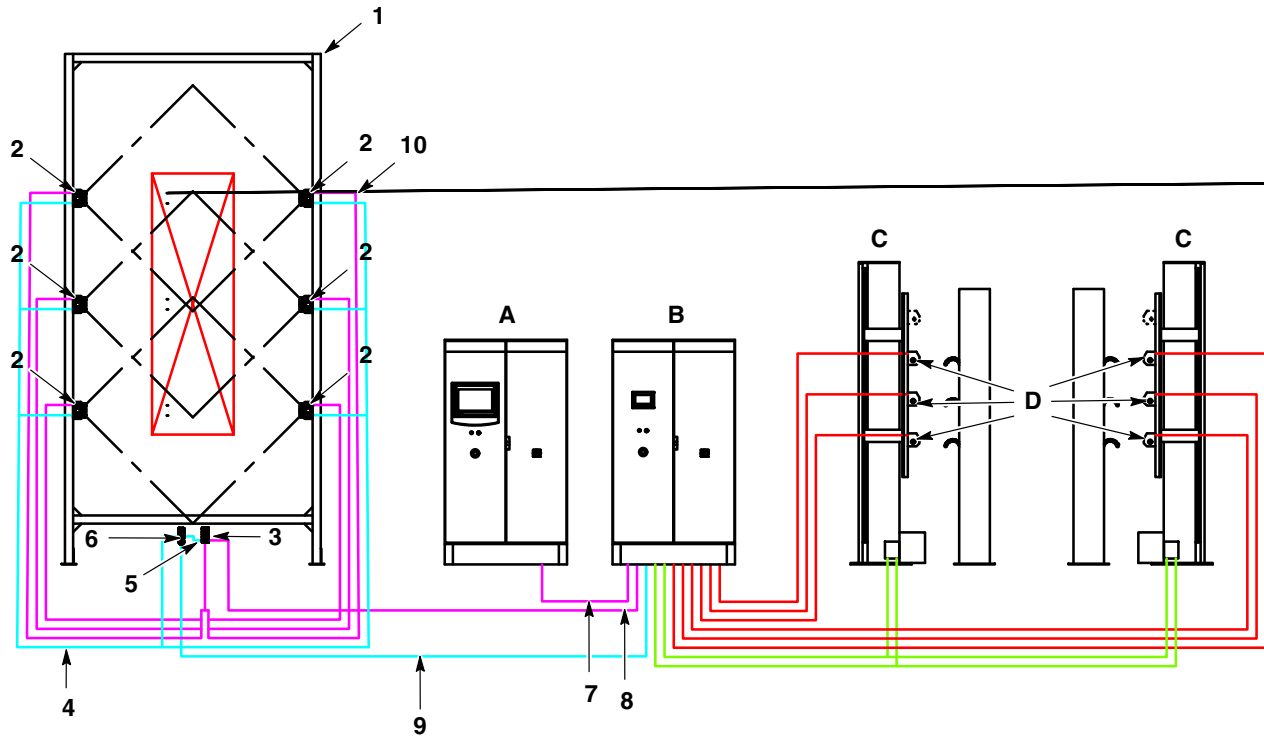

Figure 20 Laser Scanner Mounting Frame and Schematic - with Powder Pilot™ 4.X

Item	Part	Description	Quantity	Note
1	7035822	2D SCANNER STAND, DCM, GEN2	1	A
2	7035834	SCANNER, DCM, 2D LASER, GEN2	6	
—	7035932	BRACKET ADJ,SCANNER,DCM,2D LASER,GEN 2	6	B
3	7035470	ETHERNET SWITCH,2D SCANNER, DCM	1	
4	7035858	CABLE,M12,M/F,PWR,5M,2D SCANNER,GEN2	6	
5	7035859	CABLE,M12,M/F,PWR,0.3M,2D SCANNER,GEN2	1	
6	7035451	DISTRIBUTION BOX, M12x5PIN, 8 PORT, IP65	1	
7	7035681	CABLE, COMM, PN, RJ45-RJ45, 15M	1	
8	7035464	CONSOLE CABLE,LIGHT CURTAIN,M12 - RJ45,30M	1	
9	7035670	CABLE, CONN, 3x1 MM, OPEN ENDS	1	
10	7035466	CABLE, LIGHT CURTAIN, PROFINET,5M	6	
A	-	POWDER PILOT™ 4.X - <i>optional</i>	-	
B	-	DCM CONTROL CABINET	-	
C	-	RECIPROCATORS	-	
D	-	DYNAMIC CONTOURING MOVERS	-	

NOTE A: Supplied separately, without the 2D scanners. This has adjustable width and height.  
 B: 1 per scanner

# System Layout Schematic – with iControl 2 or Engage

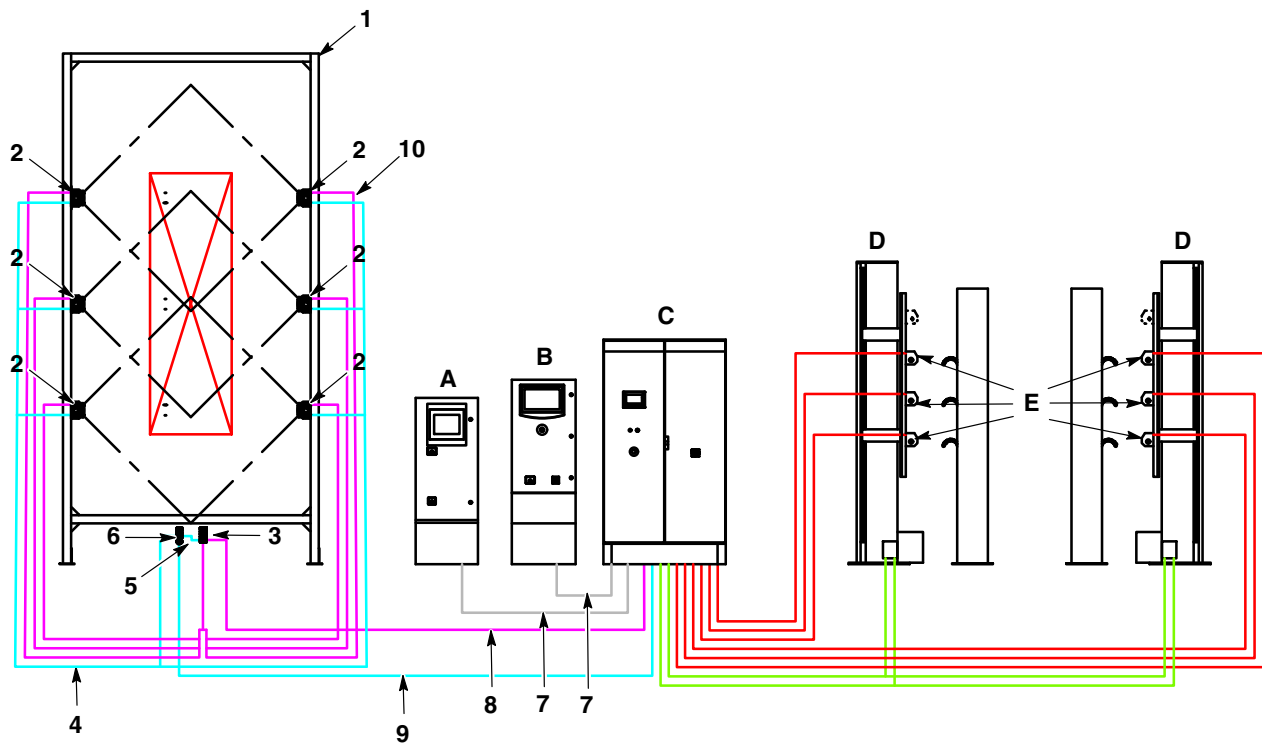

Figure 21 Laser Scanner Mounting Frame and Schematic - with iControl 2 or Encore Engage

Item	Part	Description	Quantity	Note
1	7035822	2D SCANNER STAND, DCM, GEN2	1	A
2	7035834	SCANNER, DCM, 2D LASER, GEN2	6	
—	7035932	BRACKET ADJ,SCANNER,DCM,2D LASER,GEN 2	6	B
3	7035470	ETHERNET SWITCH,2D SCANNER, DCM	1	
4	7035858	CABLE,M12,M/F,PWR,5M,2D SCANNER,GEN2	6	
5	7035859	CABLE,M12,M/F,PWR,0.3M,2D SCANNER,GEN2	1	
6	7035451	DISTRIBUTION BOX, M12x5PIN, 8 PORT, IP65	1	
7	7035675	CABLE, CONN, 25x1 MM, OPEN ENDS	1	
8	7035464	CONSOLE CABLE,LIGHT CURTAIN,M12 - RJ45,30M	1	
9	7035670	CABLE, CONN, 3x1 MM, OPEN ENDS	1	
10	7035466	CABLE, LIGHT CURTAIN, PROFINET,5M	6	
A	-	POWDER PILOT™ 4.X - <i>optional</i>	-	
B	-	DCM CONTROL CABINET	-	
C	-	RECIPROCATORS	-	
D	-	DYNAMIC CONTOURING MOVERS	-	

NOTE A: Supplied separately, without the 2D scanners. This has adjustable width and height.  
 B: 1 per scanner

## Servomotor Electrical Data

Refer to the Services drawing supplied with the system for exact specifications. Multiple connection points may be required. Below, you can see the typical values.

Description	Values
Factory ambient temperature	-15°C to 40°C
Drive unit	Servomotor
Power supply	230 v
Power consumption	200w
Frequency	50/60 Hz
Protection type	IP65
Max. torque	1.6 Nm
Weight	1.18 kg
Connection type	Hybrid Plug Connector
Connector size	M23x1

# Technical Data

**NOTE:** The Dynamic Contouring Mover is available in 4 different versions

## Dimensions and Weights

Dynamic Contouring Mover - 5 ft - HD & VT	
Total length when fully extended - HD	2663 mm
Total length when fully retracted - HD	2192 mm
Total length when fully extended - VT	2786 mm
Total length when fully retracted - VT	2322 mm
Stroke	961 mm
Weight (including 1 Encore Automatic Gun & Accessories)	11.6 kg

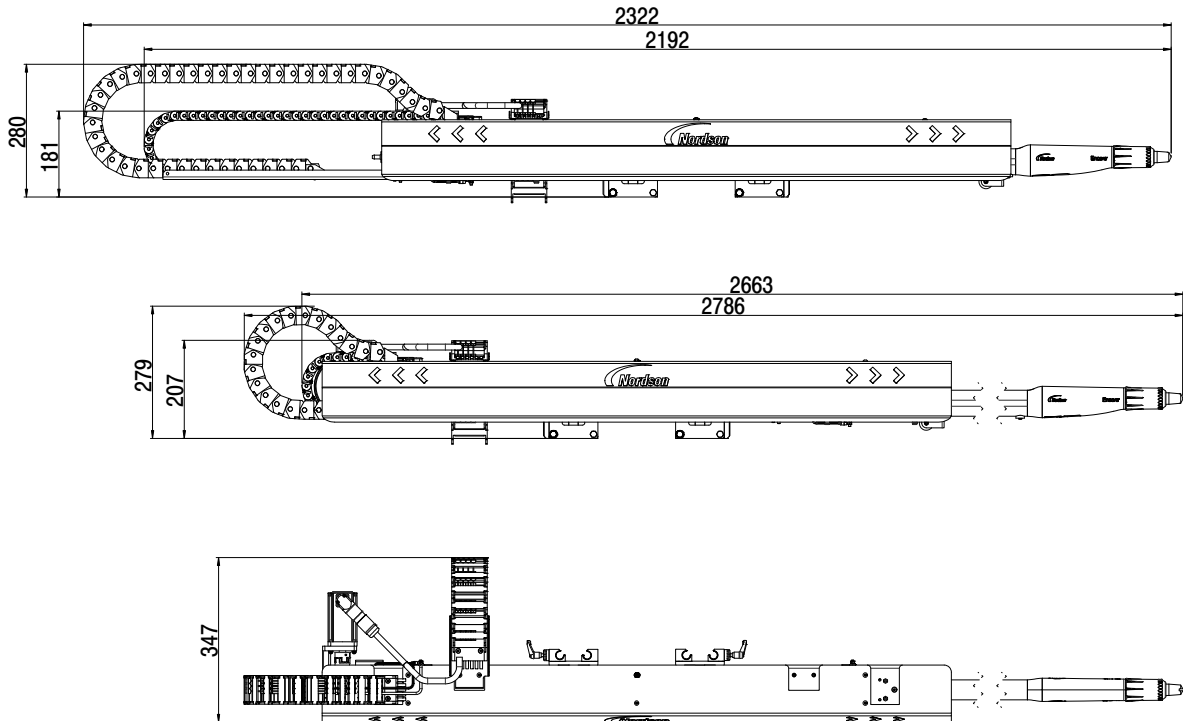

Figure 22 Encore 5ft Gun Dynamic Contouring Mover

**Dimensions and Weights(contd)**

<b>Dynamic Contouring Mover - 6 ft - HD &amp; VT</b>	
Total length when fully extended - HD	3265 mm
Total length when fully retracted - HD	2645 mm
Total length when fully extended - VT	3374 mm
Total length when fully retracted - VT	2760 mm
Stroke	1261 mm
Weight (including 1 Encore Automatic Gun & Accessories)	12.8 kg

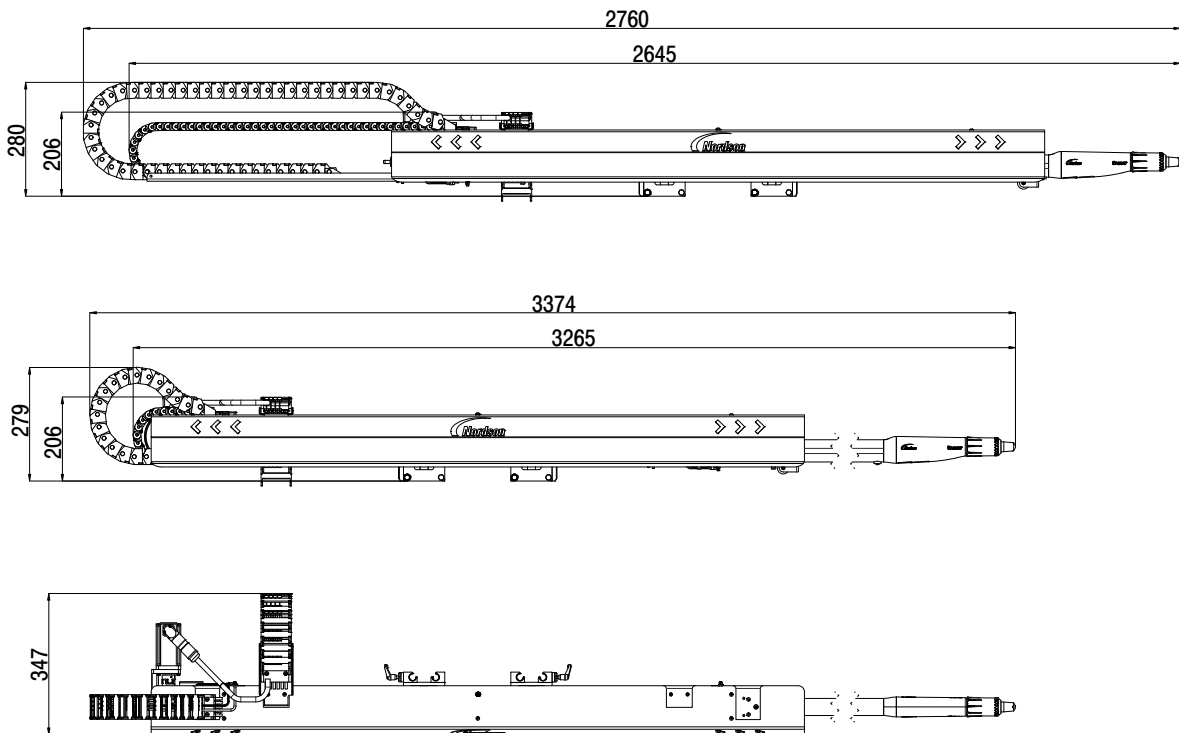

Figure 23 **Encore 6ft Gun Dynamic Contouring Mover**

**Dimensions and Weights(contd)**

<b>Dynamic Contouring Mover - 8 ft - HD &amp; VT</b>	
Total length when fully extended - HD	3265 mm
Total length when fully retracted - HD	2645 mm
Total length when fully extended - VT	3374 mm
Total length when fully retracted - VT	2760 mm
Stroke	1261 mm
Weight (including 1 Encore Automatic Gun & Accessories)	12.8 kg

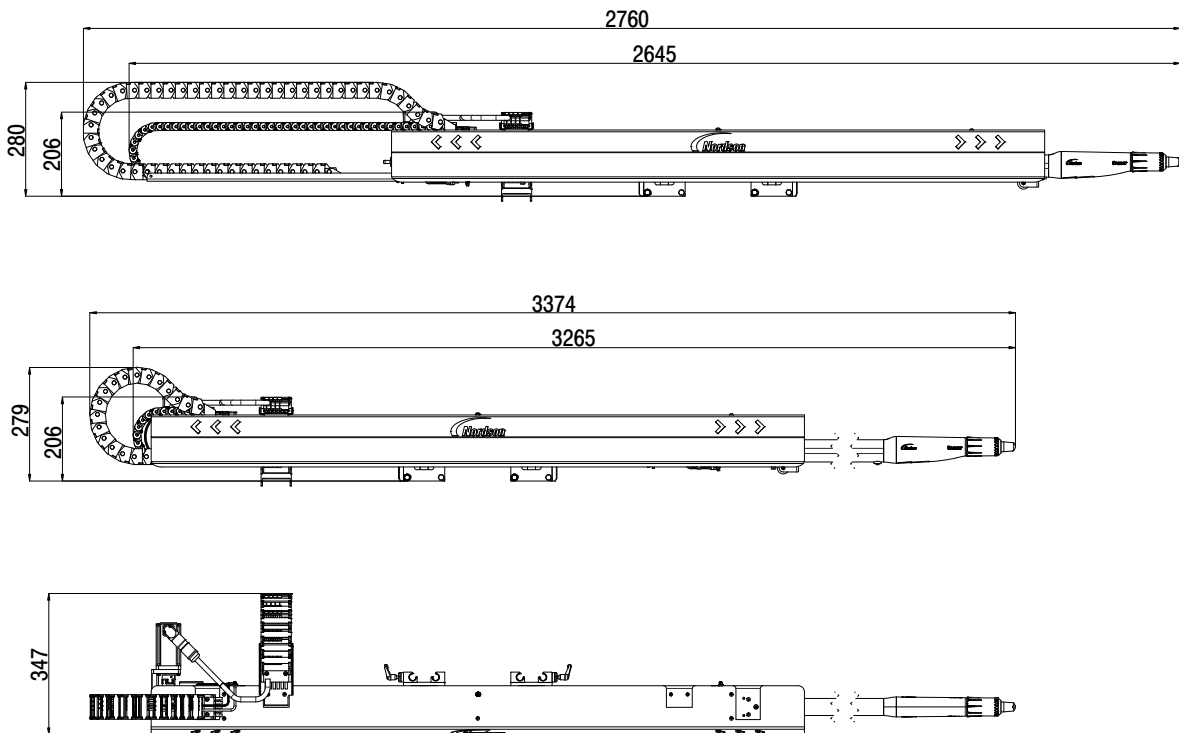

Figure 24 Encore 8ft Gun Dynamic Contouring Mover

# DCM Controller

## Description



Figure 25 **Dynamic Contouring Mover Controller**

There can be up to 3 DCM system panels coupled together giving control for up to a maximum of 36 DCM's and 6 reciprocators. The system can also be controlled remotely via a master control system like Powder Pilot for example. The system has been designed to profile and contour the guns around a variety of different customer products.

Each DCM Controller can control up to 12 Dynamic Contouring Gun Movers (DCM's), 6 Laser scanners and 2 HL reciprocators.

As the product to be coated passes through the entrance of the booth, the 2-D laser scanners determine the product's vertical and maximum width dimensions within every conveyor encoder pulse of movement. These are determined for both the left side and right side of the product. The vertical dimensions are used to assign the maximum width dimensions detected to the correct DCM.

**NOTE:** *Left side is the left whilst stood looking into the entrance of the booth*

The reciprocators then oscillate the DCM's up & down within a pre-set and fixed vertical zone.

As the product reaches the coating station, each DCM checks for any product entering its vertical zone of movement. Any product detected within the before move to after move area of the DCM will be checked to determine the widest part within that area.

The DCM will then take this dimension and add on the gun to part distance required setting the gun to this position.

# Installation

## System Configuration

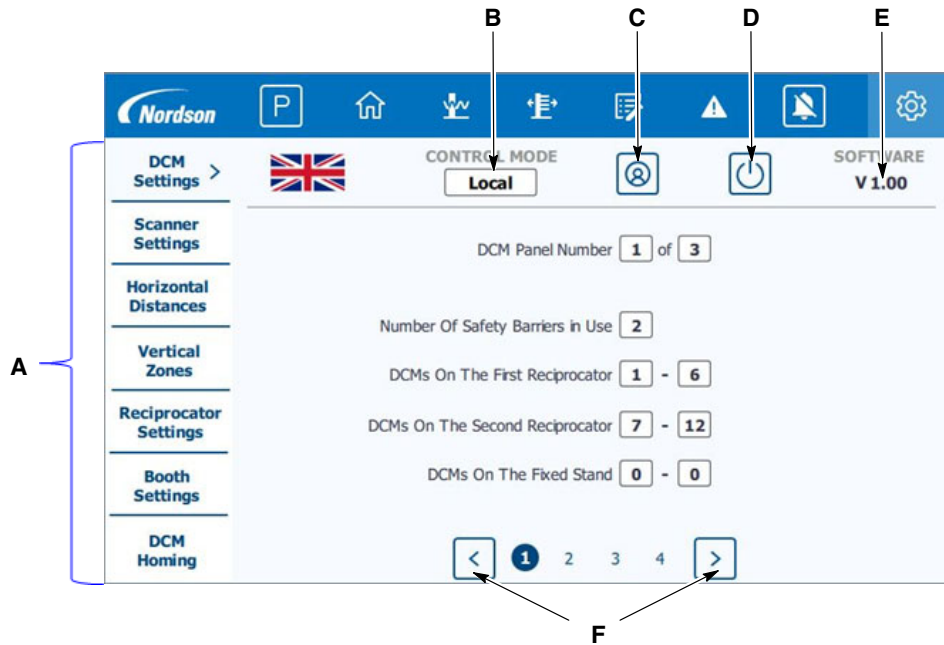

Figure 26 System Configuration Screen

- A - Touch any system section header to display the configuration entries for that section.
- B - Touch to toggle between local and remote control mode. In local mode, the DCM's operation is controlled from this touch screen. In remote mode, the DCM's operation is controlled from a master controller like Powder Pilot for example.
- C - Touch to access the user administration screen. The screen is detailed later in this manual.
- D - Touch to shut down the HMI runtime and return to the Windows desktop.
- E - Displays the software version running in the DCM control system.
- F - Touch to move backwards or forwards through the current section's configuration entries.

## System Configuration(contd)

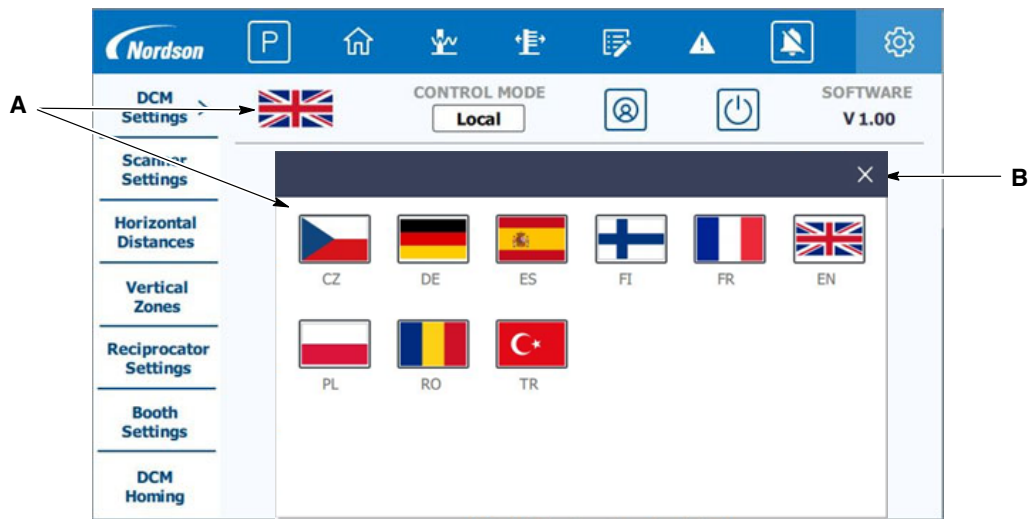

Figure 27 System Configuration Screen - Continued

A - The flag displays the country's language currently in use for all text on the HMI. Touch to display the language selection pop-up window. Touch any flag icon to display all text in the language of that country. The pop-up window will then close.

B - Touch to close the pop up window without selecting a language change.

## System Configuration(contd)

### DCM Settings

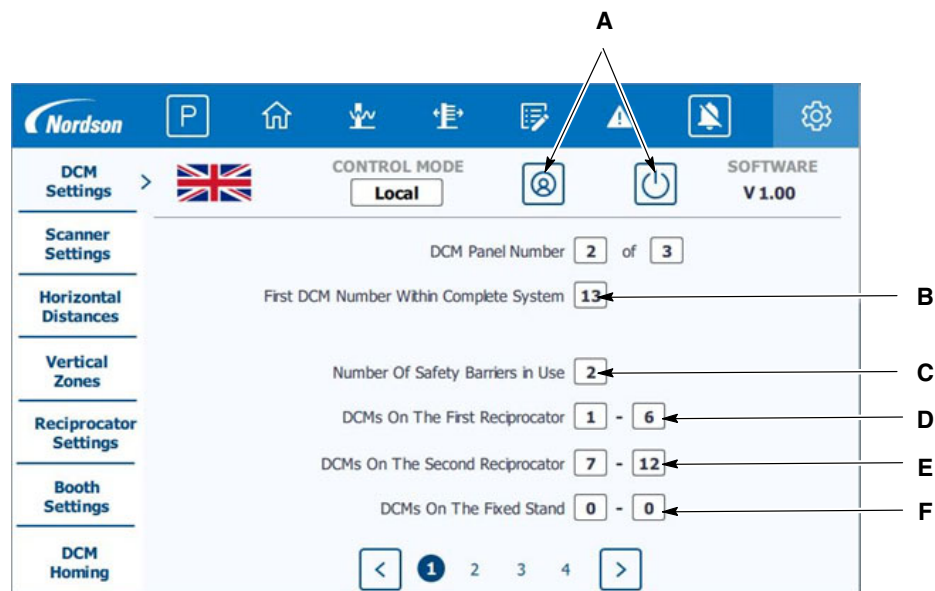

Figure 28 System Configuration Screen - DCM Settings

- A - There can be up to 3 DCM control panels used in one system. Touch to set this panel's number and the total number of panels on the system.
- B - Touch to set the number assigned to the first DCM controlled by this panel. This is the number assigned to the DCM as part of the complete system which could include multiple panels.
- C - Touch to set the total number of safety cages or safety light barriers in use on the system.

**NOTE:** Only register the devices connected to this panel.

- D - Touch to set the range of DCM's located on the first reciprocator connected to this panel.
- E - Touch to set the range of DCM's located on the second reciprocator connected to this panel.

**NOTE:** The bottom three set of entries are the DCM numbers as assigned by this local panel. So DCM's 1 - 6 for example, would be the DCM's connected to servo drives 1 - 6 of this control panel. They would actually be marked in the field as DCM's 13 - 18 since the first number within the complete system is 13.

## System Configuration(contd)

### DCM Settings(contd)

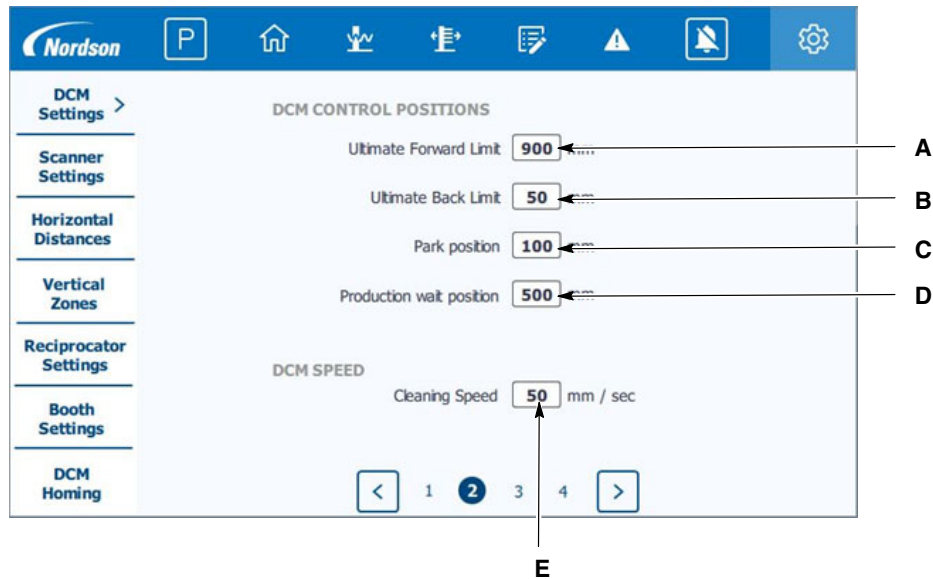

Figure 29 System Configuration Screen - DCM Settings - Continued

- A - Touch to set the maximum distance the DCM's can go forwards into the booth. This is with reference to the home position.
- B - Touch to set the maximum distance the DCM's can go backwards out of the booth. This is with reference to the home position.
- C - Touch to set the park position for the DCM's. This is the position the DCM's will go to when either the system is stopped, the park button is touched or when the internal gun hose purge function is running. This is with reference to the home position.
- D - Touch to set the position the DCM's will go to when in production, but with no product in front of them. This is with reference to the home position.
- E - Touch to set the speed at which the DCM's will come out of the booth whilst running the external gun blow off function during the cleaning sequence.

## System Configuration(contd)

### DCM Settings(contd)

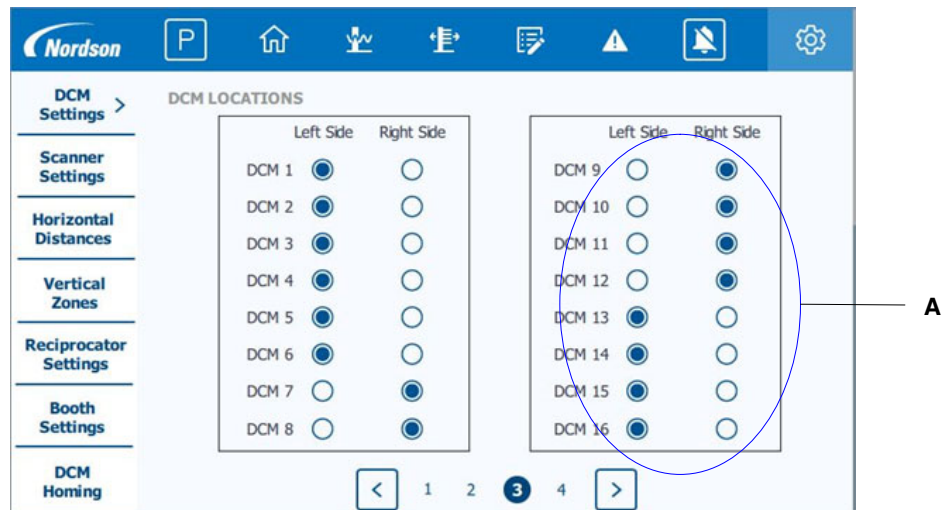

Figure 30 System Configuration Screen - DCM Settings - Continued

A - Touch to set which side of the booth each DCM is located. The DCM numbers are as assigned to this local panel so DCM 1 is the DCM connected to servo drive 1 of this panel.

**NOTE:** The left & right side is referenced whilst looking into the entrance of the booth.

## System Configuration(contd)

### DCM Settings(contd)

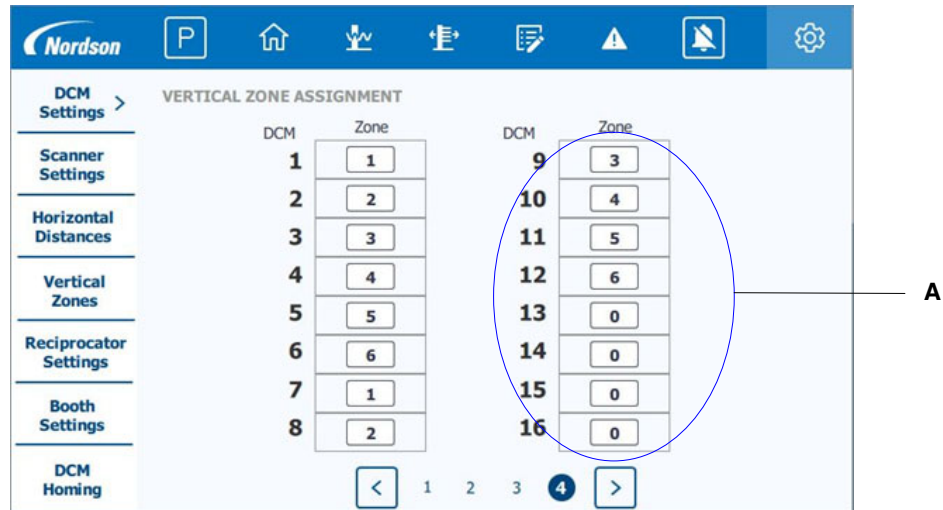

Figure 31 System Configuration Screen - DCM Settings - Continued

A - Touch to set which side of the booth each DCM is located. The dimensions of each zone are defined in the Vertical Zones configuration section. The DCM numbers are as assigned to this local panel so DCM 1 is the DCM connected to servo drive 1 of this panel.

## System Configuration(contd)

### Scanner Settings

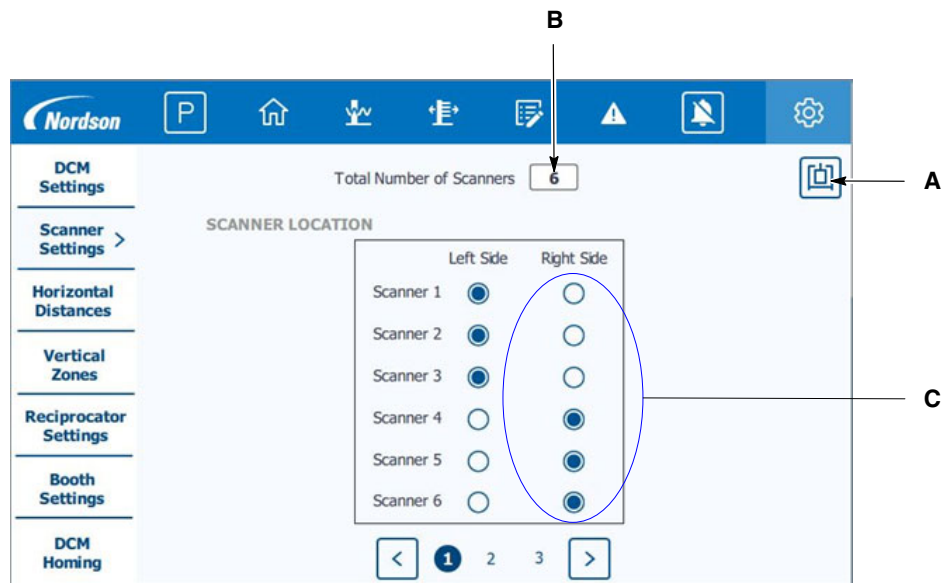

Figure 32 System Configuration Screen - Scanner Settings

A - Touch to open the scanner status screen. (see separate page - Scanner Status)

B - Touch to enter the total number of laser scanners on the system.

C - Touch to set which side of the booth each scanner is located.

**NOTE:** The left & right side is referenced whilst looking into the entrance of the booth.

## System Configuration(contd)

### Scanner Settings(contd)

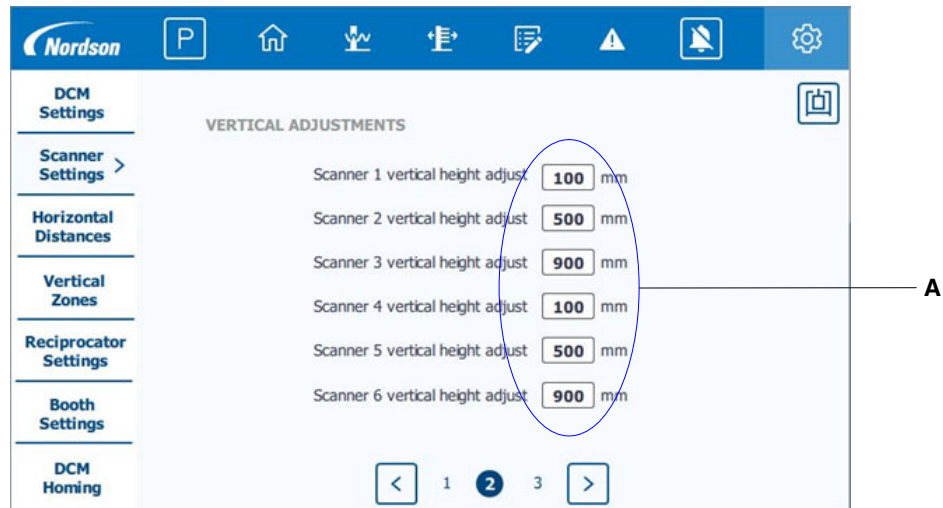

Figure 33 System Configuration Screen - Scanner Settings - Continued

A - Touch to enter the difference in height between the scanner and the top of the gun slot.  
See Appendix A - Measurements G, H & I.

## System Configuration(contd)

### Scanner Settings(contd)

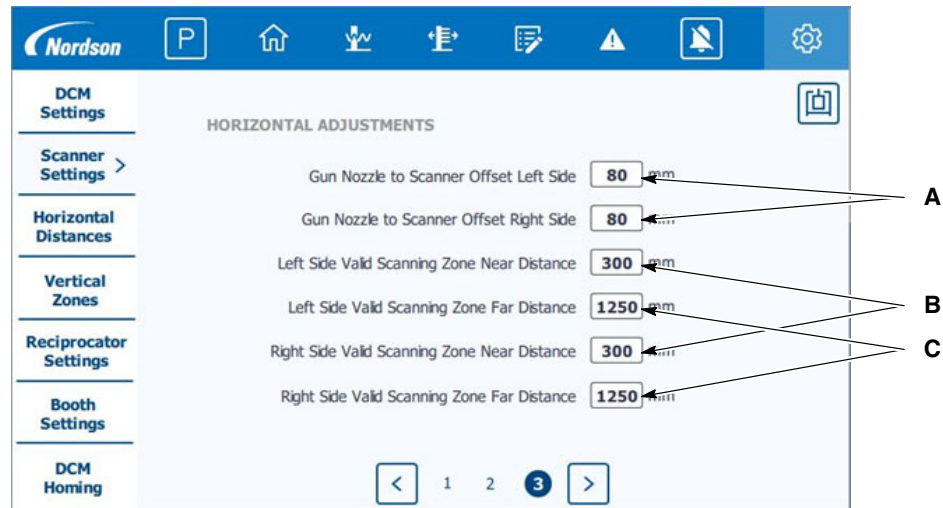

Figure 34 System Configuration Screen - Scanner Settings - Continued

- A - Touch to set the difference in the Z-axis direction, between the scanners and the gun nozzle when the DCM's are at their home positions. This assumes the scanners are closer to the centre line of the booth than the guns. If not, then it needs to be entered as a negative value.
- B - Touch to set the distance smaller than which the scanner should assume there are no parts present. This is set as the distance from the scanners to the start of the booth entrance opening in the Z direction. See Appendix A - Measurement M
- C - Touch to set the distance beyond which the scanner should assume there are no parts present. This is usually set as the distance from the scanners to half way across the opening of the booth entrance in the Z direction. See Appendix A - Measurement N

**NOTE:** The left & right side is referenced whilst looking into the entrance of the booth.  
See Appendix A - Measurements K & L

## System Configuration(contd)

### Scanner Status

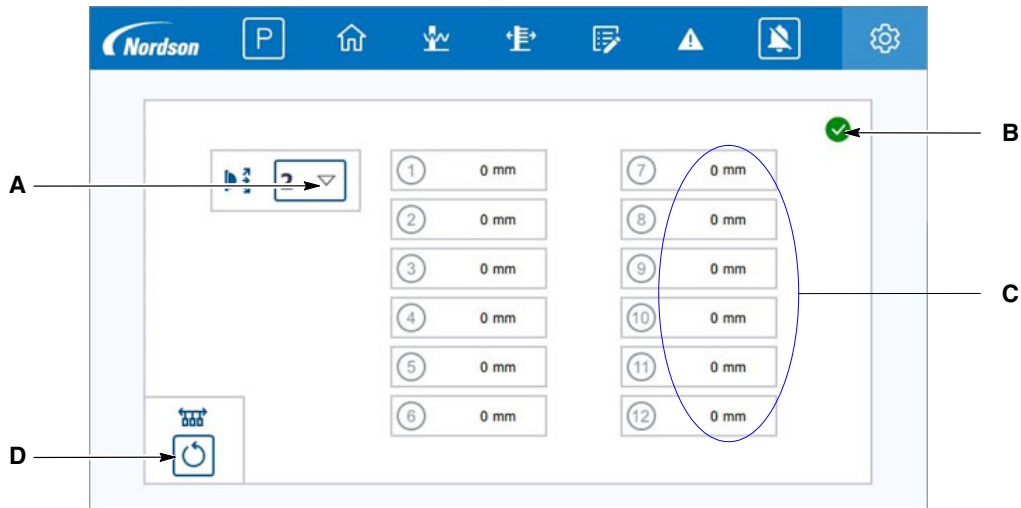



Figure 35 System Configuration Screen - Scanner Status - Continued

- A - Press to select which scanner's data is to be displayed.
- B - Displays overall current health state of the scanners. The highest fault level from any scanner is displayed.
- C - This section displays the widest dimension currently being detected in each of the 12 vertical zones by the scanner selected. These dimensions are the distance measured from the scanner head to the part being detected. Therefore, the smaller the dimension, the wider the part actually is.
- D - Press to reset the part tracking memory.

**NOTE:** Press  on any scanner settings page to access the scanner status screen.

## System Configuration(contd)

### Horizontal Distances

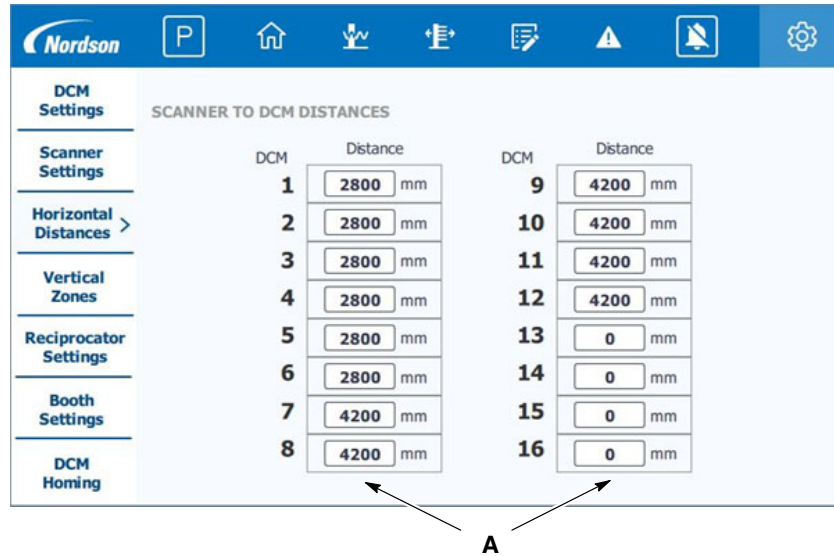

Figure 36 System Configuration Screen - Horizontal Distances

A - Touch to set the distance in conveyor direction, from the scanners to the gun nozzle on the DCM. There is an entry for each DCM. See Appendix A - Measurements C & D.

**NOTE:** The DCM numbers are as assigned to this local panel so DCM 1 is the DCM connected to servo drive 1 of this panel.

## System Configuration(contd)

### Vertical Zone Definition

DCM Settings		Total No. of vertical zones		6	
Zone	Top Dimension of Zone	Bottom Dimension of Zone	Zone	Top Dimension of Zone	Bottom Dimension of Zone
1	50 mm	350 mm	7	0 mm	0 mm
2	350 mm	650 mm	8	0 mm	0 mm
3	650 mm	950 mm	9	0 mm	0 mm
4	950 mm	1250 mm	10	0 mm	0 mm
5	1250 mm	1550 mm	11	0 mm	0 mm
6	1550 mm	1850 mm	12	0 mm	0 mm

Callout A points to the 'Total No. of vertical zones' field (value: 6).  
 Callout B points to the 'Bottom Dimension of Zone' field for Zone 6 (value: 1850 mm).  
 Callout C points to the 'Top Dimension of Zone' field for Zone 6 (value: 1550 mm).

Figure 37 System Configuration Screen - Vertical Zone Definition

This section defines the vertical zones that each DCM strokes over whilst oscillating on the reciprocator. Each DCM is assigned to one of these vertical zones in page 4 of the DCM Settings section.

A - Touch to set the number of vertical zones required for the system.

B - This entry sets the bottom dimension of vertical zone 6. See Appendix A measurement F.

C - This entry sets the top dimension of vertical zone 6. See Appendix A measurement E.

**NOTE:** These dimensions are measured down from the top of the gun slot.

## System Configuration(contd)

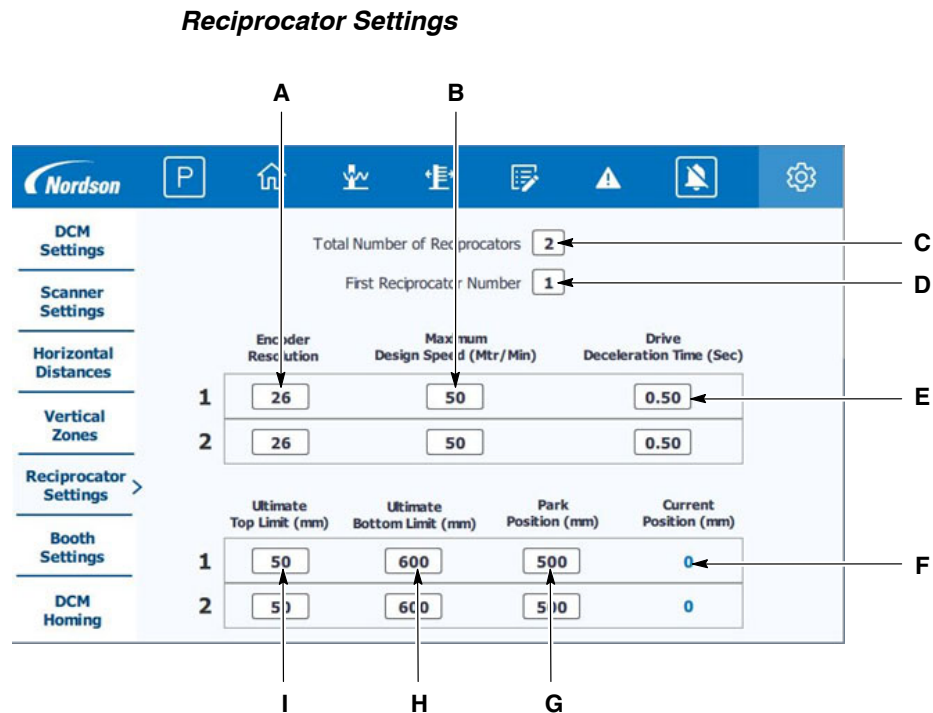

Figure 38 System Configuration Screen - Reciprocator Settings

- A - Touch to set the number of pulses received from the reciprocator position encoder for every 1mm of carriage movement. This value is usually 26 for an HL 100 reciprocator.
- B - Touch to set the maximum design speed of the reciprocator in metres / minute. This value is usually 50 for an HL 100 reciprocator.
- C - Touch to set the total number of reciprocators connected to this panel.
- D - Touch to set the number of the first reciprocator connected to this panel.
- E - Touch to set the current deceleration time programmed into the inverter drive at parameter P1121. This value is usually 0.5 for a HL reciprocator.
- F - This value displays the current position of the reciprocator with reference to the top limit switch.
- G - Touch to set the park position for the reciprocator. This is with reference to the top limit switch.
- H - Touch to set the lowest point the reciprocator is allowed to go down to. This is with reference to the top limit switch.
- I - Touch to set the highest point the reciprocator is allowed to go up to. This is with reference to the top limit switch.

## System Configuration(contd)

### Booth Settings

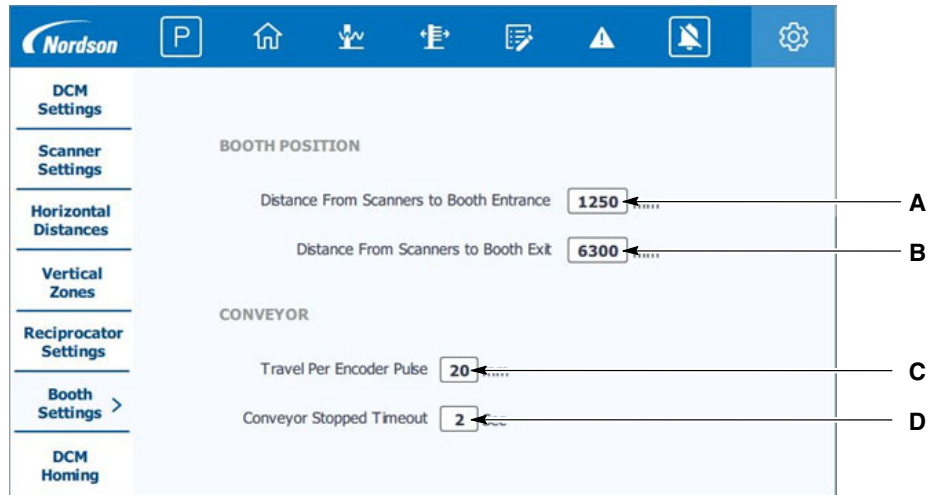

Figure 39 System Configuration Screen - Booth Settings

- A - Touch to set the distance between the scanners and the entrance of the booth in the direction of conveyor travel. See Appendix A - Measurement A
- B - Touch to set the distance between the scanners and the exit of the booth in the direction of conveyor travel. See Appendix A - Measurement B
- C - Touch to set the number of mm of conveyor travel per encoder pulse received.
- D - Touch to set the number of mm of conveyor travel per encoder pulse received.

## System Configuration(contd)

### DCM Homing

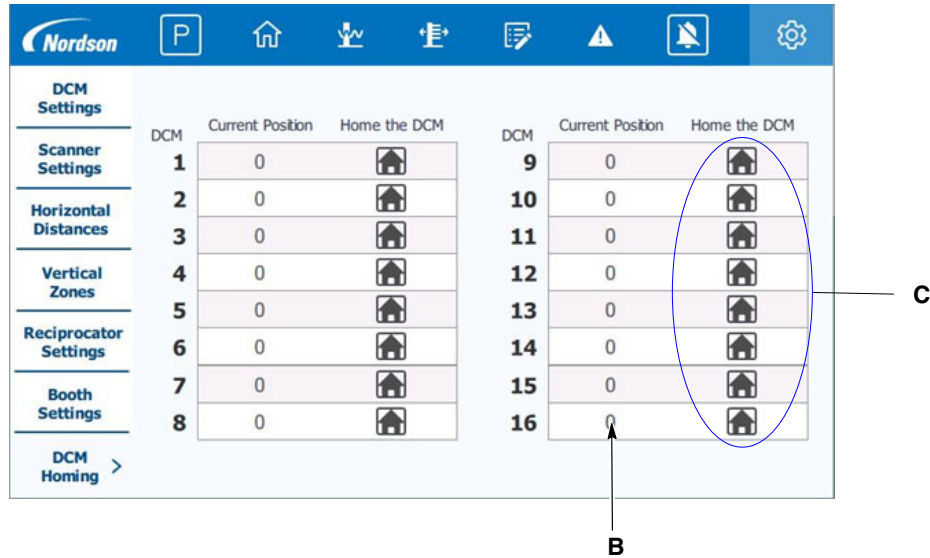

Figure 40 System Configuration Screen - DCM Homing

This process sets the current position of the DCM to 0mm. This is only necessary if the drive coupling has slipped or if the DCM motor or mover has been replaced.

A - The first step is to switch off servo drive control power from the DCM to be homed. Then manually pull the drive back until the mark on the carriage lines up with the home mark on the frame. Press the relevant home button to home the drive.

B - Ensure the relevant position value then shows 0mm.

**NOTE:** The DCM numbers are as assigned to this local panel so DCM 1 is the DCM connected to servo drive 1 of this panel.

## System Configuration(contd)

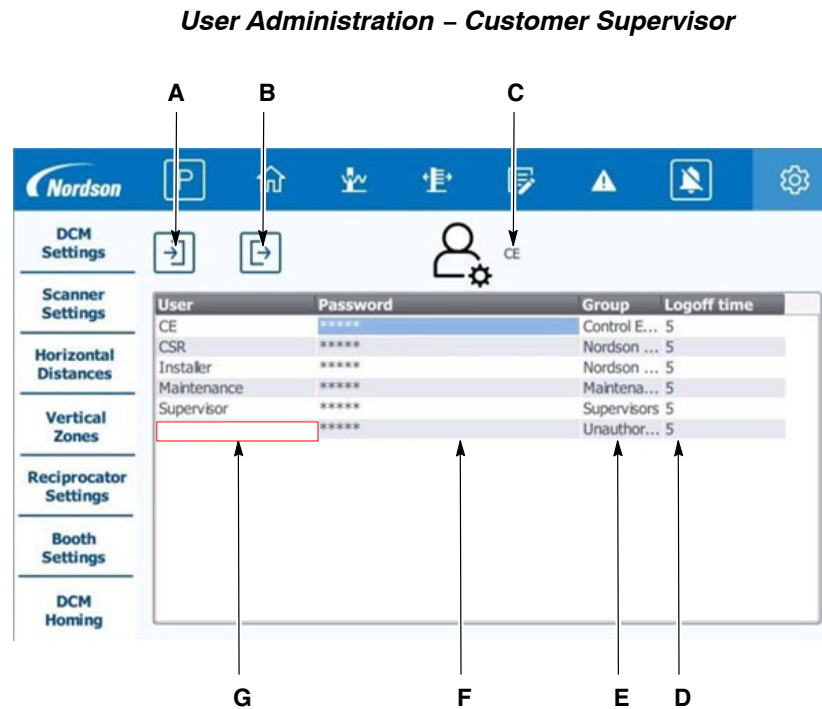

Figure 41 System Configuration Screen - User Admin

New users with their own password and access level can be added here.

**NOTE:** This is can only be done by someone logged in at Supervisor level.

A - Press to log in a new user.

B - Press to log out the current user.

C - Displays the current user logged in.

D - Touch this area to adjust the number of minutes before the user is automatically logged out if there has been no interaction with the screen. Setting a value of 0 will disable the auto logout function for this user.

E - Touch this area to reveal a drop down list of user levels. Assign the new user a level of operator, Lead operator, Maintenance or Supervisor.

F - Touch this area to reveal a pop up where the new user's password can be entered.

G - Firstly, double touch in this area under the last entry to create a new user line.

# Operation

## System Start Up

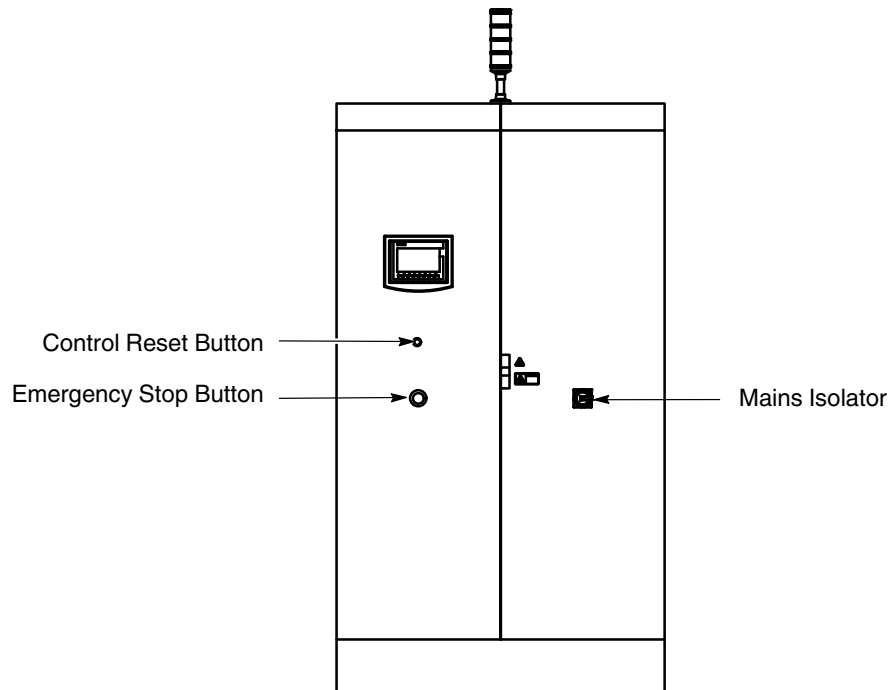

Figure 42 **Dynamic Contouring Mover Controller**

1. Ensure the area around the DCM's is clear of personnel and obstructions.
2. Turn the Mains isolator on.
3. Wait for the touch screen to boot up and display the main start screen.
4. Ensure the emergency stop button on the control panel is pulled out.
5. Ensure any external emergency stop buttons are pulled out if installed.
6. Press the Control Reset button.

At this stage the reciprocators will drive to their top limit switches to find their zero points after which they will drive to their Park positions.

The DCM's will go directly to their Park positions if not already there.

**NOTE:** The DCM's will remain at their Park positions after the system is first powered up until the conveyor has travelled at least the distance equal to that from the laser scanners to the DCM's. This is to ensure the system's tracking memory knows where all products are located within the booth area.

## Global Navigation Bar

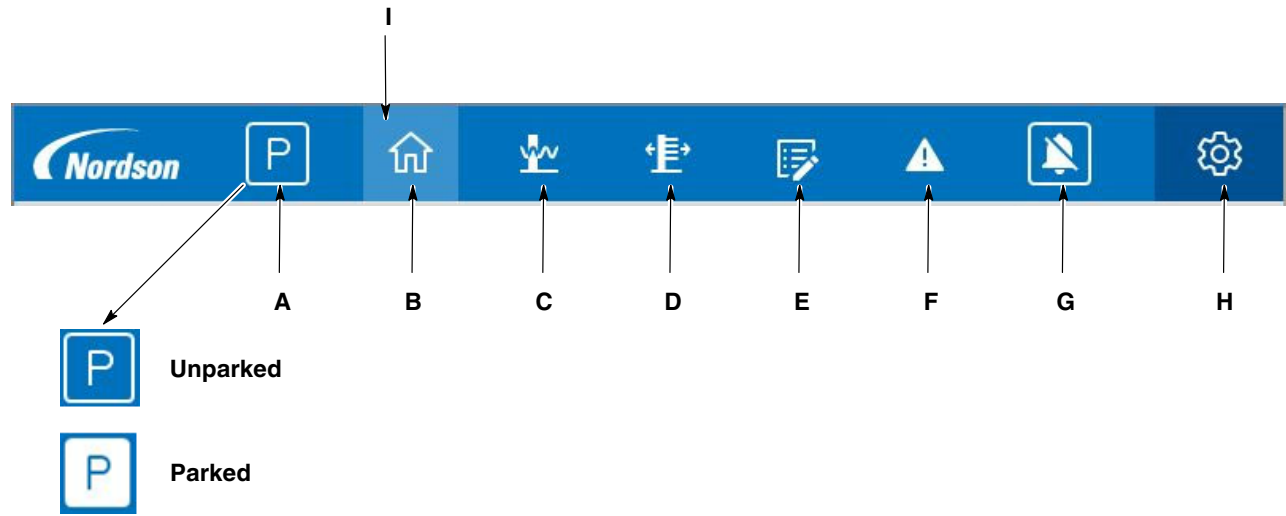

Figure 43 Global Navigation Bar

The global navigation bar is as shown above and is located at the top of every user screen.

A - Touch to *Park* or *Unpark* the movers.

**NOTE:** The movers will automatically *Unpark* when product enters the booth.

B - Touch to display the main start screen.

C - Touch to display the reciprocator control screen.

D - Touch to display the DCM mover control screens.

E - Touch to display the mover program edit screens.

F - Touch to display the current alarms list.

G - Touch to mute the alarm sounder.

H - Touch to enter the system configuration screens.

I - Lighter background highlights the current screen accessed.

## Main Start Screen

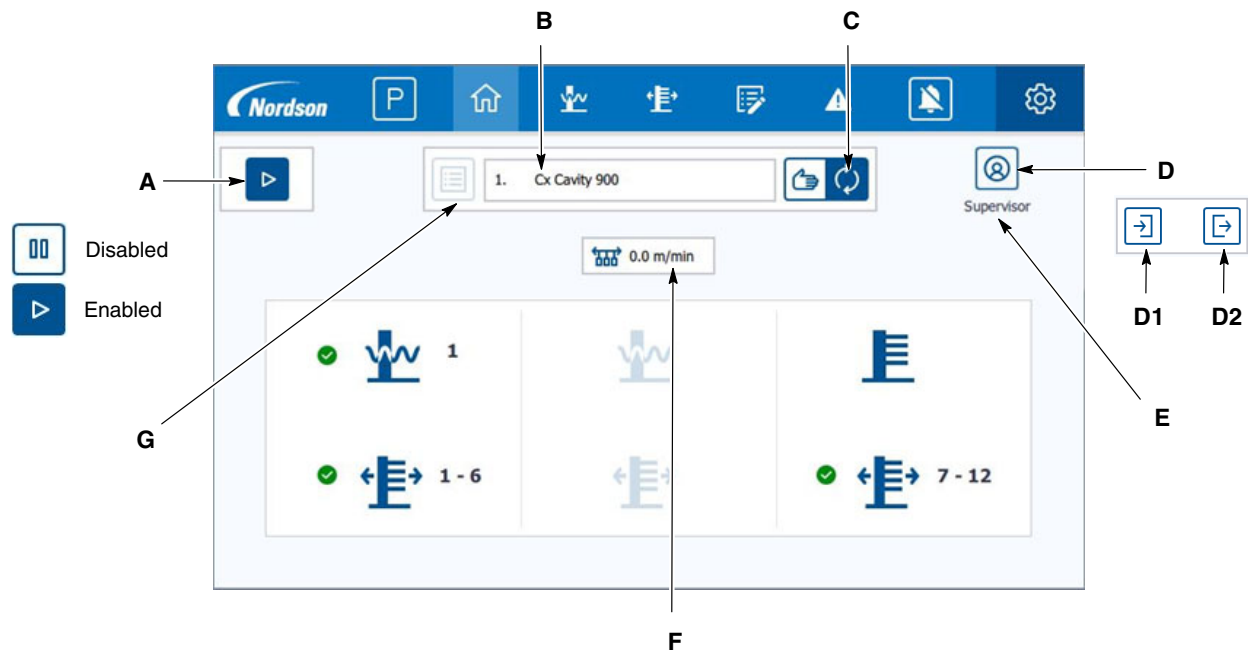

Figure 44 Main Start Screen

A - Touch this button to *disable* or *enable* the DCM system for production.

B - Displays the name and number of the current mover program loaded.

C - Touch to select *auto* or *manual* program loading mode. Auto mode is shown as selected here. In auto mode, an external control system selects the mover program to use. In manual mode, the program is selected by the operator on this touch screen.

D - Touch to display the user login and logout buttons.

D1 - Press to display the login prompt.

D2 - Press to logout the current user.

E - Displays the current user logged in.

F - Current conveyor speed for indication purposes only in metres / minute.

G - Touch this button to load a mover program manually, as detailed in the next section.

## Main Start Screen(contd)

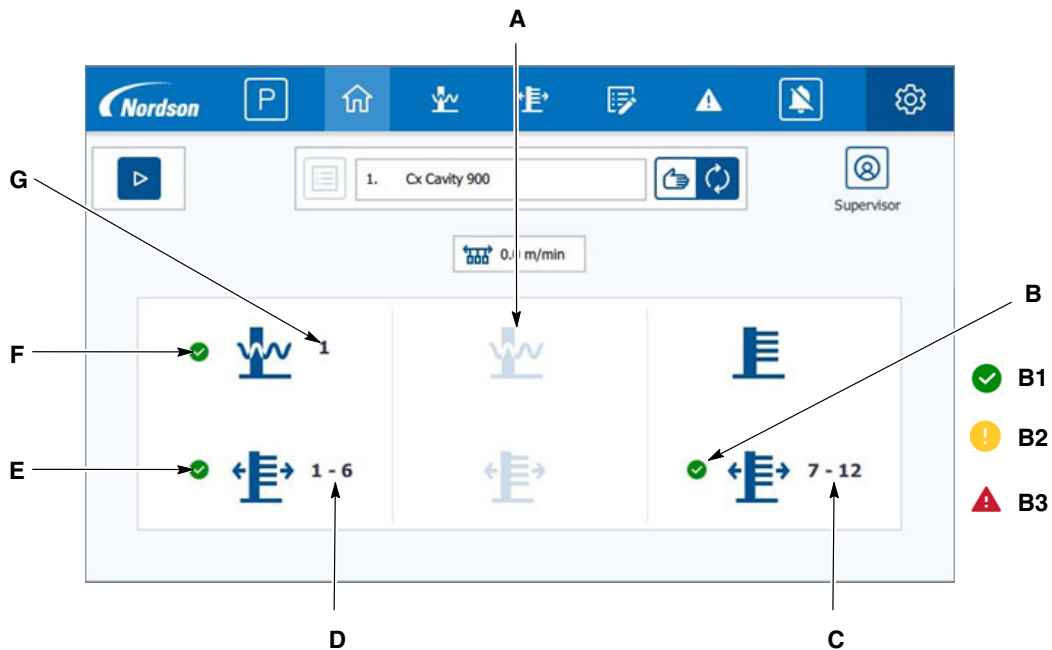

Figure 45 Main Start Screen

A - This section displays the health status of the second reciprocator and the DCM range located on it. Any section will be greyed out as shown here if that reciprocator or fixed gun stand doesn't exist on the system.

B - Overall health status of the DCM's located on the fixed gun stand. All health status symbols are defined as follows:

B1 - All OK

B2 - Indicates an issue that will not stop its ability to produce.

B3 - Indicates a problem that will stop its ability to produce.

C - DCM range located on the fixed gun stand.

D - DCM range located on the first reciprocator.

E - Overall health status of the DCM's located on the first reciprocator.

F - Health status of the first reciprocator on the system .

G - First reciprocator number.

## Manual Program Load Control

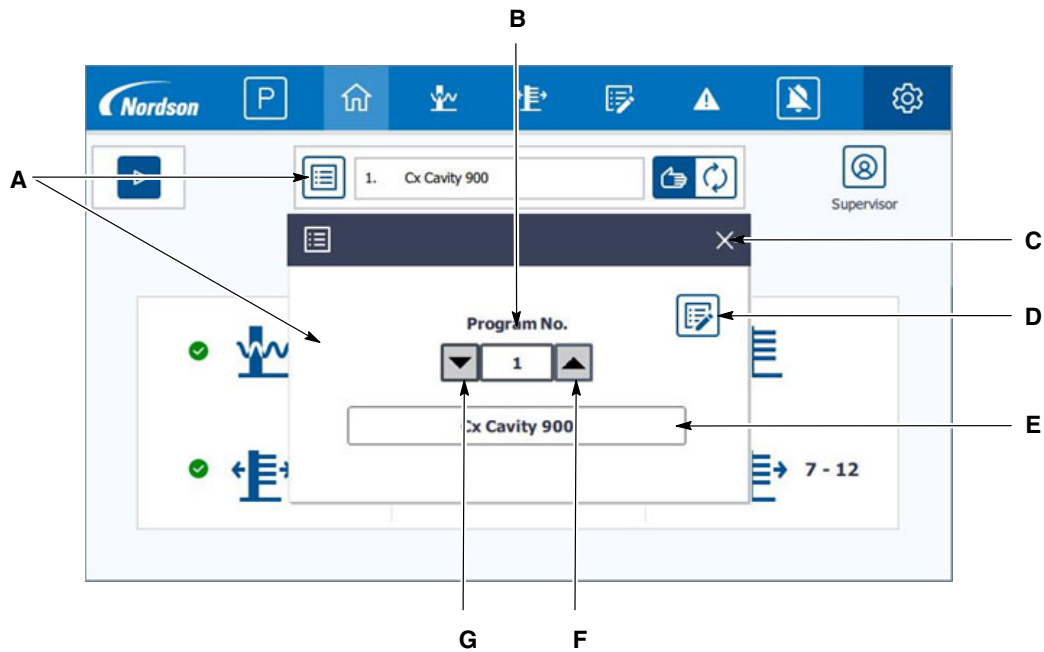

Figure 46 Main Program Load Screen

- A - Touch this button to display the manual program load control panel.
- B - Touch to reveal a keyboard and enter the program number required.
- C - Touch to close the program load control panel.
- D - Touch to load the program selected.
- E - This field displays the name of the program number selected.
- F - Touch to increase the program number by one each Touch.
- G - Touch to decrease the program number by one each Touch.

## Reciprocator Control

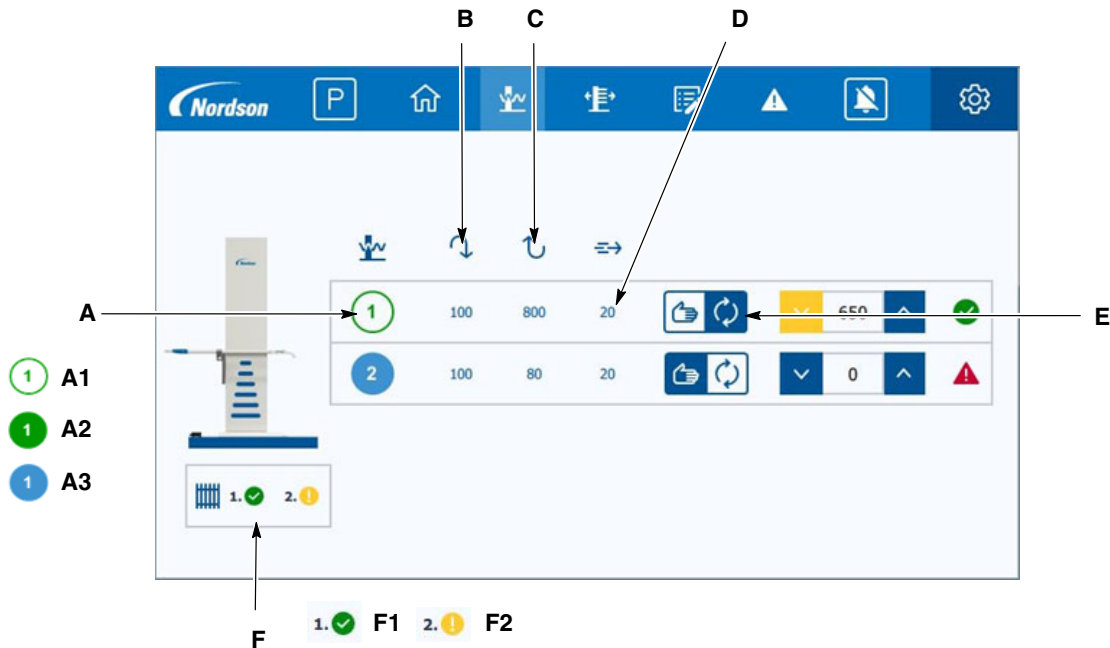

Figure 47 Reciprocator Control Screen

A - Reciprocator number and status.

A1 - Reciprocator stopped

A2 - Reciprocator running

A3 - Reciprocator stopped in its park position

B - Touch to set the top turn around point. This is measured in mm down from the top of the booth gun slot.

C - Touch to set the bottom turn around point. This is measured in mm down from the top of the booth gun slot.

D - Touch to adjust the reciprocator speed of travel in metres / minute.

E - Touch to toggle operation mode between automatic & manual. This icon currently indicates automatic mode.

**NOTE:** : When the reciprocator is set to automatic mode and unparked, it will continuously travel between the top and bottom turn around points at the set speed. When set to manual mode, it will only move whilst the up or down button is being touched.

F - Safety gate or light barrier status.

F1 - This indicates the gate or light barrier for the first reciprocator is ok. The reciprocators can run.

F2 - This indicates the gate or light barrier for the 2nd reciprocator is tripped. The reciprocators cannot run. The area must be cleared of personnel and the control reset button pressed.

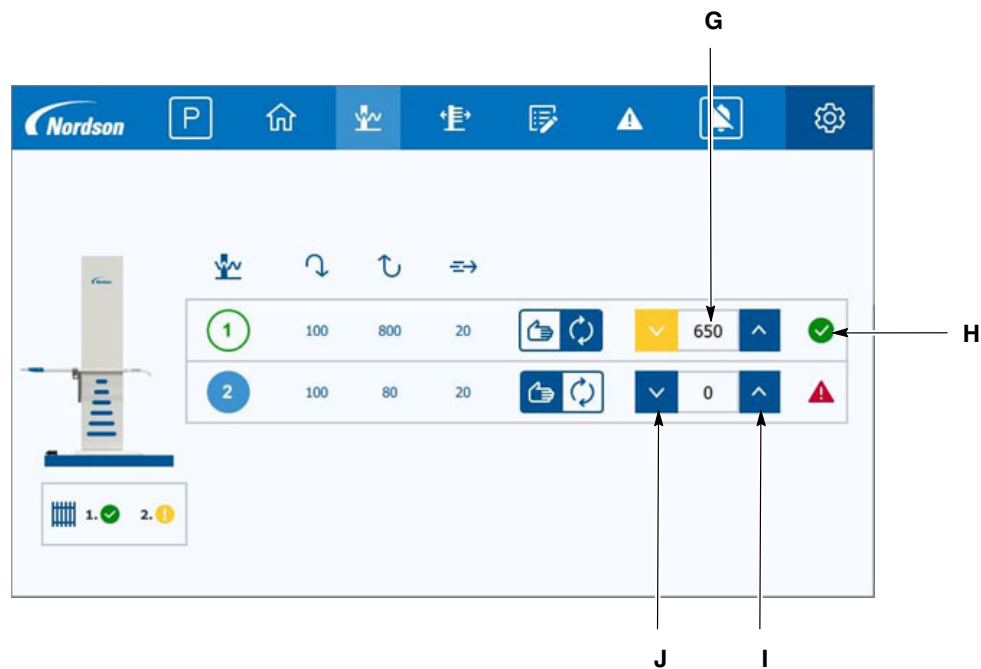
**Reciprocator Control(contd)**Figure 48 **Reciprocator Control Screen - Continued**

G - Current reciprocator position in mm. This is with reference to the top of the booth gun slot. Refer to image 43.

H - Current health state of the reciprocator.

I - When set to manual mode, touch this button to move the reciprocator up. Release the button to stop movement. The button will turn yellow when the carriage has reached the upper end of travel limit switch.

J - When set to manual mode, touch this button to move the reciprocator down. Release the button to stop movement. The button will turn yellow when the carriage has reached the lower end of travel limit switch.

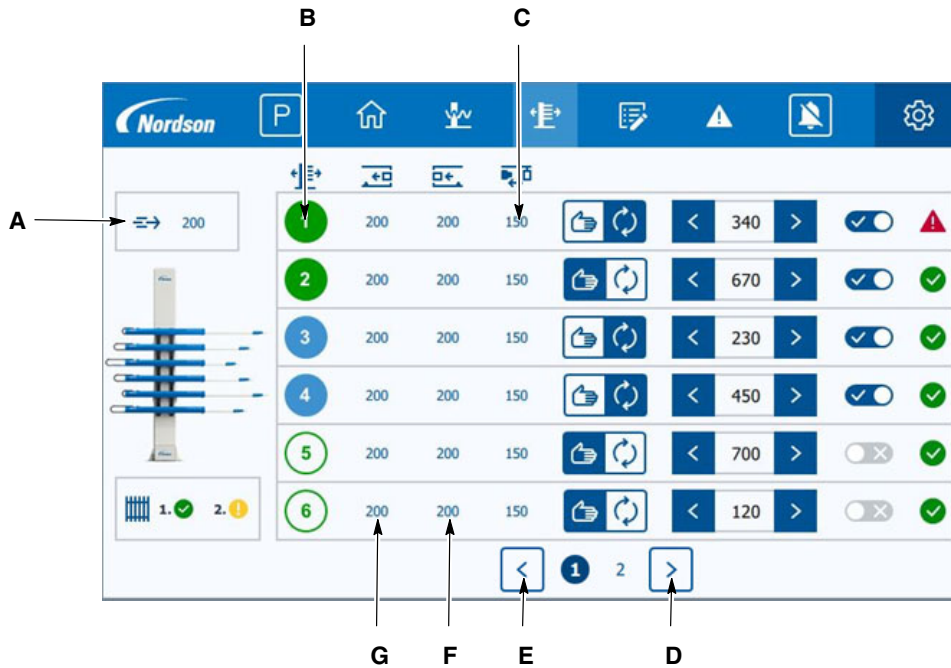
**DCM Control**Figure 49 **DCM Control Screen**

A - Touch to set the DCM's speed of travel during production, entered in mm/second.

**NOTE:** This value is applied to all DCM's.

B - DCM number and status.

C - Touch to set the required gun to part distance in mm.

D - Touch to display DCM's 7-12.

E - Touch to display DCM's 1-6

F - Touch to set how many millimetres after the part passes the gun before it moves back to its wait position

G - Touch to set how many millimetres before the part arrives, that the DCM will then move to its gun to part distance.

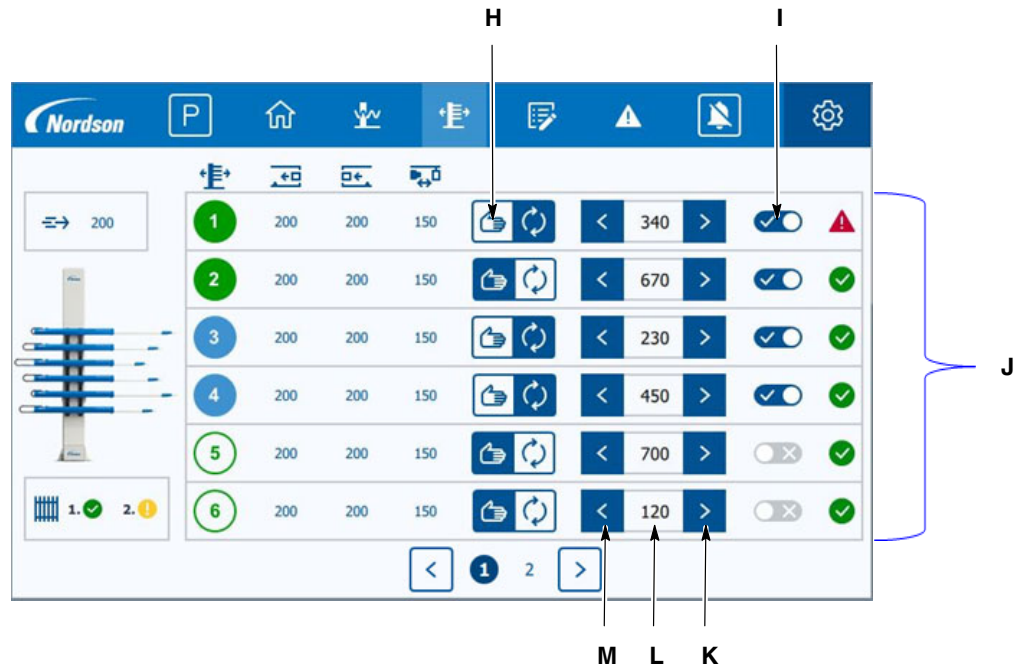
**DCM Control(contd)**Figure 50 **DCM Control Screen - Continued**

H - Touch to toggle operation mode between automatic & manual. Showing automatic mode here.

I - Touch to turn servo drive control power on or off.

J - Current health state of the DCM.

K - When set to manual mode, touch this button to move the DCM into the booth. Release the button to stop movement.

L - Displays the current position in mm. This is with reference to the home position.

M - When set to manual mode, touch this button to move the DCM out of the booth. Release the button to stop movement.

**NOTE:** : When the DCM is set to automatic mode and unparked, it will profile around the product maintaining the required gun to part distance. When set to manual mode, it will only move whilst the *In* or *Out* button is being touched.

## Program Editing

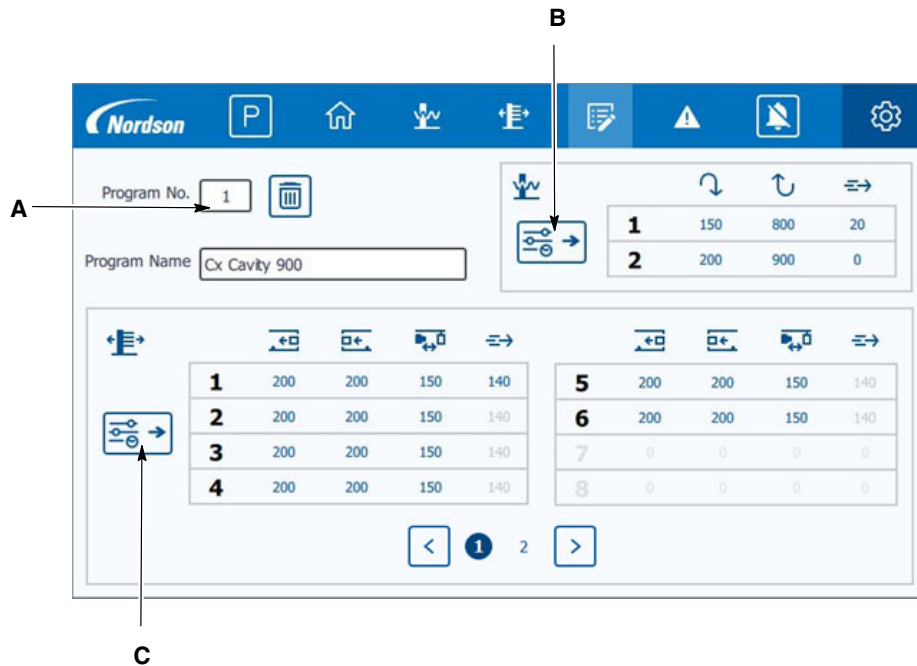
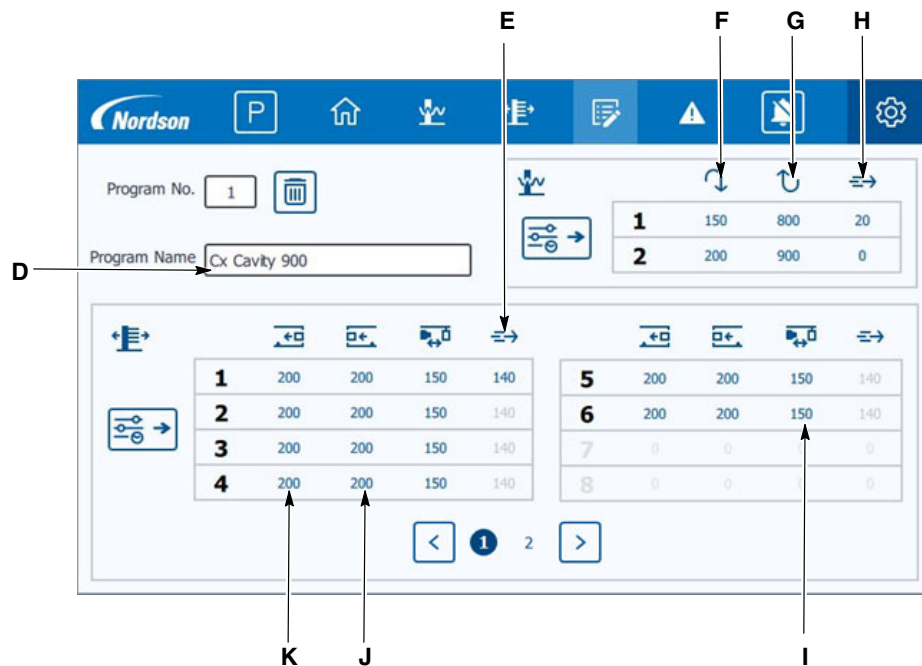

Figure 51 Program Editing Screen

- A - The system has up to 255 programs available. To modify the settings within a program, firstly enter the program number to be edited here. All pre-stored parameters and the name given to this program will then be displayed in the tables opposite. Any stored setting can be adjusted by touching that setting's number and entering a new value. All new settings are automatically stored within the program. No Save action is required.
- B - Touch this button to copy all settings currently running in the reciprocators into this program table. The current settings running in the reciprocators can be seen and adjusted live from the reciprocator control screen described on pages 7 & 8 of this operator card.
- C - Touch this button to copy all settings currently running in the DCM's into this program table. The current settings running in the DCM's can be seen and adjusted live from the DCM control screens described on pages 9 & 10 of this operator card.

**Program Editing(contd)**Figure 52 **Program Editing Screen - Continued**

D - Touch to enter a name for the program number selected.

E - Touch to set in the program the DCM speed of travel during production, entered in mm/second.

**NOTE:** : This can only be entered for DCM 1. The value set is then used for all DCM's.

F - Touch to set in the program the reciprocator speed of travel in metres / minute.

G - Touch to set in the program the reciprocator bottom turn around point. This is measured in mm down from the top of the booth gun slot.

H - Touch to set in the program the reciprocator top turn around point. This is measured in mm down from the top of the booth gun slot.

I - Touch to set in the program the gun to part distance required in mm.

J - Touch to set in the program how many millimetres after the part passes the gun before it moves back to its wait position.

K - Touch to set in the program how many millimetres before the part arrives, that the DCM will then move to its gun to part distance.

## Program Editing(contd)

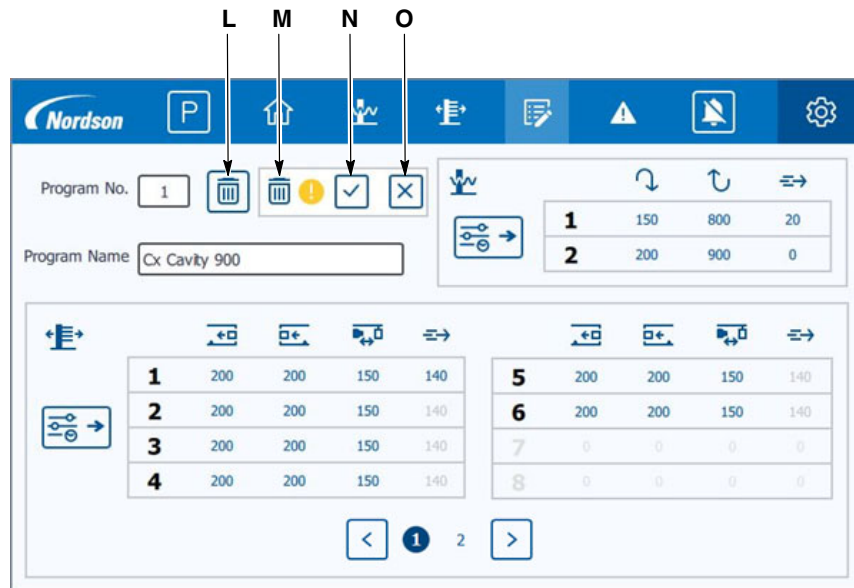

Figure 53 Program Editing Screen - Continued

L - Touch this button to delete any previously stored settings in the program.

M - Once touched, a window will appear to confirm if the program data should really be deleted.

N - Touch to confirm all data should be deleted. Once touched, the confirm window will disappear again. All program data will be reset to minimum configuration values.

O - Touch to cancel delete procedure. Once touched, the confirm window will disappear again and all data will remain as before.

## System Alarm List

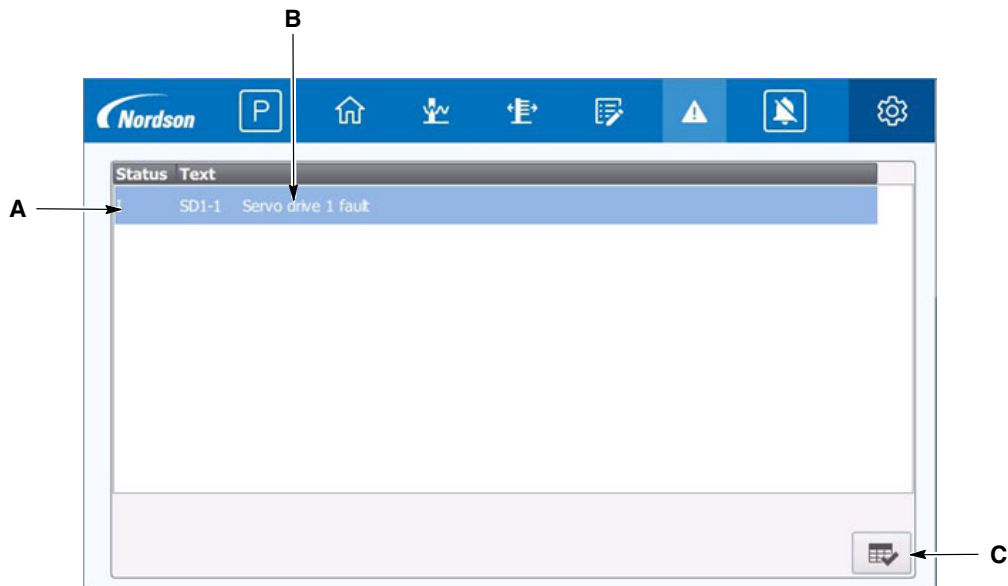

Figure 54 Program Editing Screen - Continued

A - Alarm's current status:

I = Incoming alarm. Alarm is active

A = Alarm has been acknowledged

O = Outgoing alarm. The fault condition has cleared

B - Alarm ID and description

C - Touch to acknowledge any new alarms. They will then clear from the list when the fault condition has gone.

## Stand Alone System Colour Change

The stand alone colour change sequence will run as follows

Feed Centre	DCM System
<i>“Colour Change in progress” signal from Feed Centre to DCM System</i>	Movers driven to purge positions
Run gun hose purge	<i>“Movers in purge position” signal from DCM System to Feed Centre</i>
Hose purge completed <i>“External gun blow-off cycle” signal from Feed Centre to DCM System</i>	All gun mover go fully in
Left side blow-off solenoid turned on	Left side movers retract at blow-off speed <i>“External blow-off solenoid left side” signal from DCM System to Feed Centre</i>
Right side blow-off solenoid turned on	When all left side movers are fully out, right side movers retract at blow-off speed <i>“External blow-off solenoid right side” signal from DCM System to Feed Centre</i>
Sequence complete	When all <u>right side</u> movers are fully out <i>“External blow-off complete” signal from DCM System to Feed Centre</i>

Colour change interface. If the DCM system is set to run in stand alone mode without a master controller, it will interface with the Global Feed Centre colour change sequence. This is achieved using 24V digital input and volt free digital output signals.

If the DCM system is connected to a master controller, the colour change sequence is completely defined by the master controller.

The master controller can send the DCM’s fully in, fully out, to purge position as well as move out at external gun blow off speed. This is achieved using Profinet communication.

## Maintenance

The DCM Controller has been tested according to the following Standards:

### **DIN VDE 0113 / EN 60204 / BGV A3**

As part of your annual maintenance program, the DCM Controller should be tested to the same Standards by your chosen qualified engineer.

## Repair



**WARNING:** Allow only qualified personnel to perform the following tasks. Follow the safety instructions in this document and all other related documentation.



**WARNING:** Hazardous voltages exist within the DCM console. Unless power must be on to test circuits, always shut off and lock out power before opening the console to make repairs. All repairs should be made by a qualified electrician. Failure to observe this warning could result in personal injury or death. Repair consists of removing malfunctioning components and replacing them with new ones. There are no components inside the cabinet that can be repaired by the customer. Refer to the wiring diagrams for connections.



**WARNING:** Whenever replacing a component that interfaces with the exterior of the cabinet, such as a gun harness receptacle, make sure that the dust-tight integrity of the cabinet is intact by installing the correct gaskets and seals. Failure to maintain the dust-tight integrity of the cabinet could invalidate agency approvals and create a hazardous condition.

# Troubleshooting



**WARNING:** Allow only qualified personnel to perform the following tasks. Follow the safety instructions in this document and all other related documentation.

Alarm Code & Message	Corrective Action
<b>Booth - Safety Barriers</b>	
BO-5 Safety barrier 1 is open or tripped	Ensure the safety zone is clear of personnel. Close the gate if safety cages installed. Ensure the outside perimeter of the safety zone is clear of all objects if light barriers are installed. Press the control reset push button on the control panel door.
BO-6 Safety barrier 2 is open or tripped	
<b>Control Panel</b>	
CP-2 Communication lost to slave PLC -15K5	Ensure there is 24V power to the -15K5 PLC. Check the Ethernet cable from the -15K5 PLC to the Ethernet switch is not damaged and is also connected properly.
CP-3 Communication lost to master controller	If no master controller exists, ensure the system is set to local control mode. Ensure the master controller is powered on. Check the Ethernet cable between the master controller and DCM control panel is not damaged and is also connected properly.
ES-1 Emergency stop relay de-energized	Ensure all emergency stop buttons are pulled out and press the control reset button on the control panel front door.
<b>Laser Scanner</b>	
LS1-1 Scanner 1 is Offline, Check Scanner LED Status	Ensure the scanner is powered. Check the Ethernet cable from the scanner to the local Ethernet switch on the scanner stand is not damaged and is also connected properly.
LS2-1 Scanner 2 is Offline, Check Scanner LED Status	
LS3-1 Scanner 3 is Offline, Check Scanner LED Status	
LS4-1 Scanner 4 is Offline, Check Scanner LED Status	
LS5-1 Scanner 5 is Offline, Check Scanner LED Status	
LS6-1 Scanner 6 is Offline, Check Scanner LED Status	
<b>Remote Program Control</b>	
PL-1 Program number requested by master controller is out of valid range 1-255	Check the master controller to ensure it's sending a program number within the valid range.
<b>Reciprocator 1</b>	
RC1-1 First reciprocator has not initialised	Check if the safety cages are open and if so, close them. Ensure the reciprocator carriage can reach the top limit switch unrestricted and that the top limit switch is working correctly.
RC1-2 First reciprocator inverter drive fault	Check the frequency inverter display for a fault code. Then consult your Nordson service engineer for further information on the specific fault.
RC1-3 First reciprocator has over travelled its top limit	Set the reciprocator to manual mode and bring it back into range in the middle of its stroke.
RC1-4 First reciprocator has over travelled its bottom limit	
RC1-5 First reciprocator is not sensed as moving on command	Check reciprocator encoder is functioning. Check the drive system is not restricted.
RC1-6 First reciprocator inverter drive supply has tripped	Check relevant circuit breaker, identifiable from the system drawings provided.
<i>Continued...</i>	

Alarm Code & Message	Corrective Action
RC1-7 First reciprocator turn around limits are too close or inverted	Open out the turn around limits to make the stroke longer. If running a short stroke, reduce the speed.
RC1-8 The first reciprocator cannot initialise as some DCM's are not in their park positions	Ensure all the DCMs are in their park positions. Check the DCMs are in auto mode and that the servo drive control power selectors are all enabled.
<i>Continued...</i>	
Alarm Code & Message	Corrective Action
<b>Reciprocator 2</b>	
RC2-1 Second reciprocator has not initialised	Check if the safety cages are open and if so, close them. Ensure the reciprocator carriage can reach the top limit switch unrestricted and that the top limit switch is working correctly.
RC2-2 Second reciprocator inverter drive fault	Check the frequency inverter display for a fault code. Then consult your Nordson service engineer for further information on the specific fault.
RC2-3 Second reciprocator has over travelled its top limit	Set the reciprocator to manual mode and bring it back into range in the middle of its stroke.
RC2-4 Second reciprocator has over travelled its bottom limit	
RC2-5 Second reciprocator is not sensed as moving on command	Check reciprocator encoder is functioning. Check the drive system is not restricted.
RC2-6 Second reciprocator inverter drive supply has tripped	Check relevant circuit breaker, identifiable from the system drawings provided.
RC2-7 Second reciprocator turn around limits are too close or inverted	Open out the turn around limits to make the stroke longer. If running a short stroke, reduce the speed.
RC2-8 The second reciprocator cannot initialise as some DCM's are not in their park positions	Ensure all the DCMs are in their park positions. Check the DCMs are in auto mode and that the servo drive control power selectors are all enabled.
<b>Servo Drive</b>	
SD-2 24V lost to servo drives 1 to 6	Check the 24V electronic overload module identifiable from the system drawings. Reset the output channel if tripped.
SD-3 24V lost to servo drives 9 to 12	
SD1-1 Servo drive 1 fault	Check the servo drive display for a fault code. Then consult your Nordson service engineer for further information on the specific fault.
SD2-1 Servo drive 2 fault	
SD3-1 Servo drive 3 fault	
SD4-1 Servo drive 4 fault	
SD5-1 Servo drive 5 fault	
SD6-1 Servo drive 6 fault	
SD7-1 Servo drive 7 fault	
SD8-1 Servo drive 8 fault	
SD9-1 Servo drive 9 fault	
SD10-1 Servo drive 10 fault	
SD11-1 Servo drive 11 fault	
SD12-1 Servo drive 12 fault	

If you cannot solve a problem with the information given on the Alarm List, contact your local Nordson representative for help.

## Wiring Diagram

**NOTE:** Electrical and Pneumatic drawings will be supplied with the system. For more information please contact your Nordson representative.

Description	Drawing Number
6 * DCM GEN 2	7035709
12 * DCM GEN 2	7035712

# Appendix A – System Dimensions

## Scanners to Booth

NOTE: Figures shown are examples

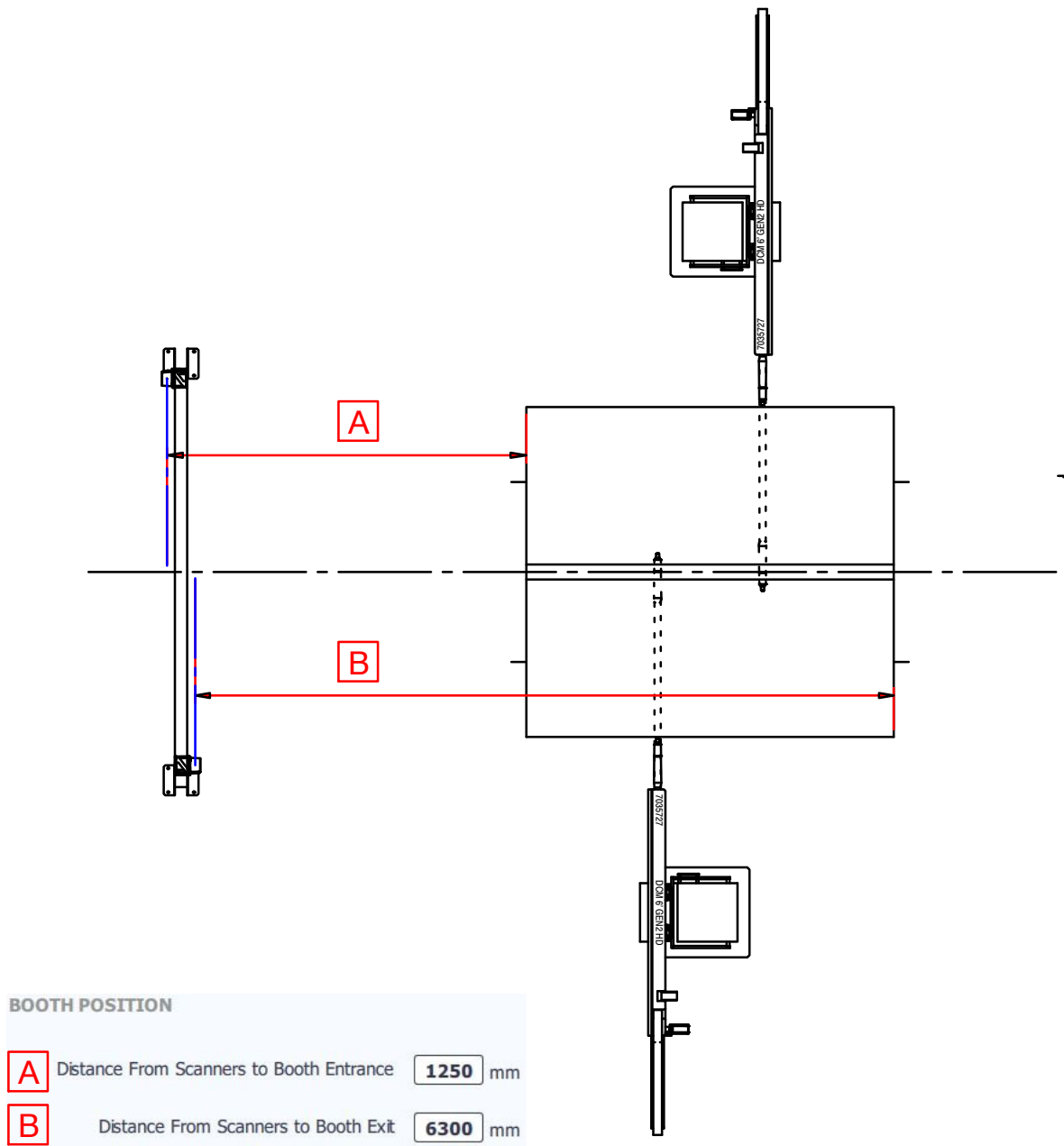

Figure 55 Distances from Scanners to Booth

# Appendix A – System Dimensions(contd)

## Scanners to DCM's

NOTE: Figures shown are examples

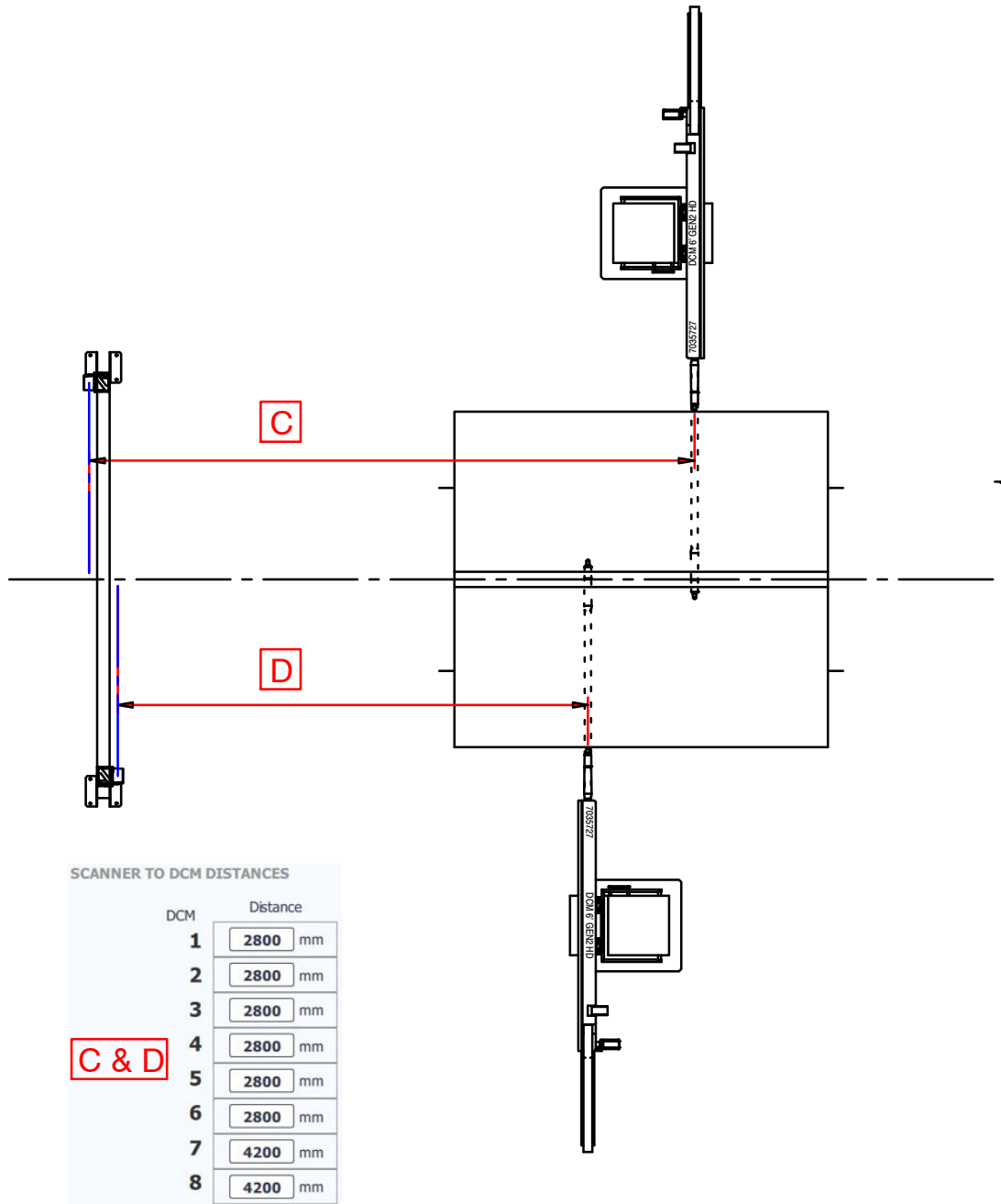
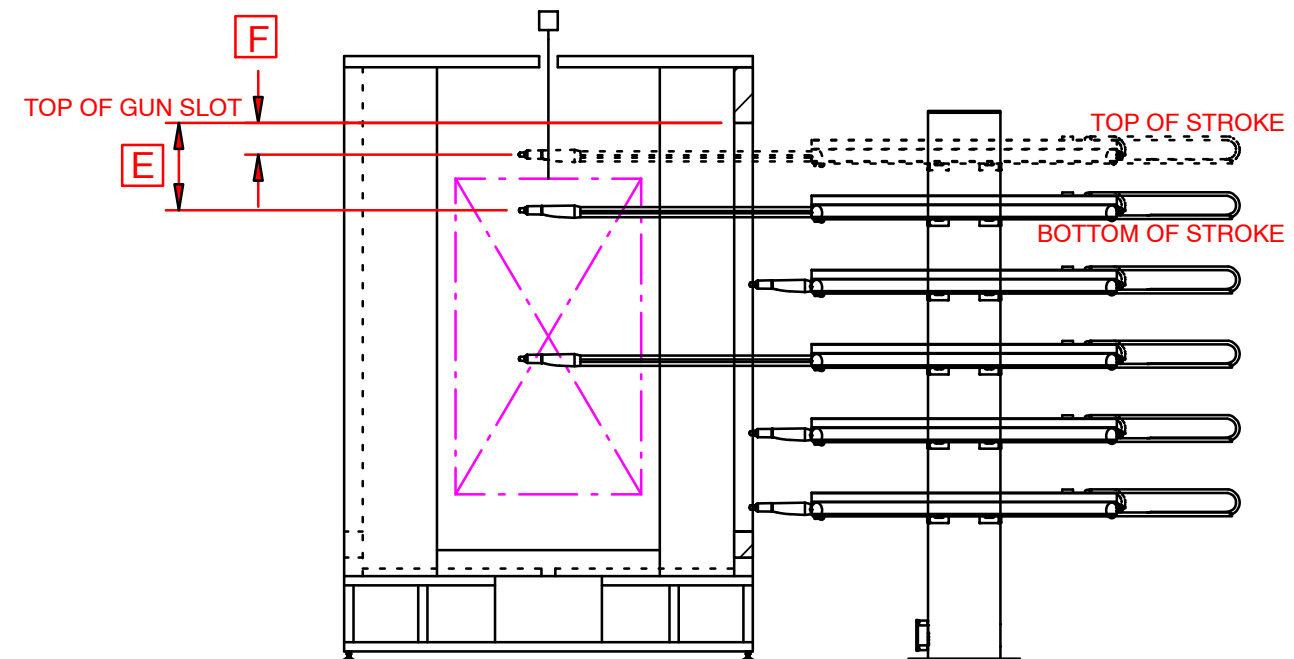

Figure 56 Distances from Scanners to DCM's

# Appendix A – System Dimensions(contd)

## Zones

NOTE: Figures shown are examples



Zone	<b>E</b> Top Dimension of Zone	<b>F</b> Bottom Dimension of Zone
1	50 mm	350 mm
2	350 mm	650 mm
3	650 mm	950 mm
4	950 mm	1250 mm
5	1250 mm	1550 mm
6	1550 mm	1850 mm

Figure 57 Zone Dimensions

# Appendix A – System Dimensions(contd)

## Vertical Adjustments

NOTE: Figures shown are examples

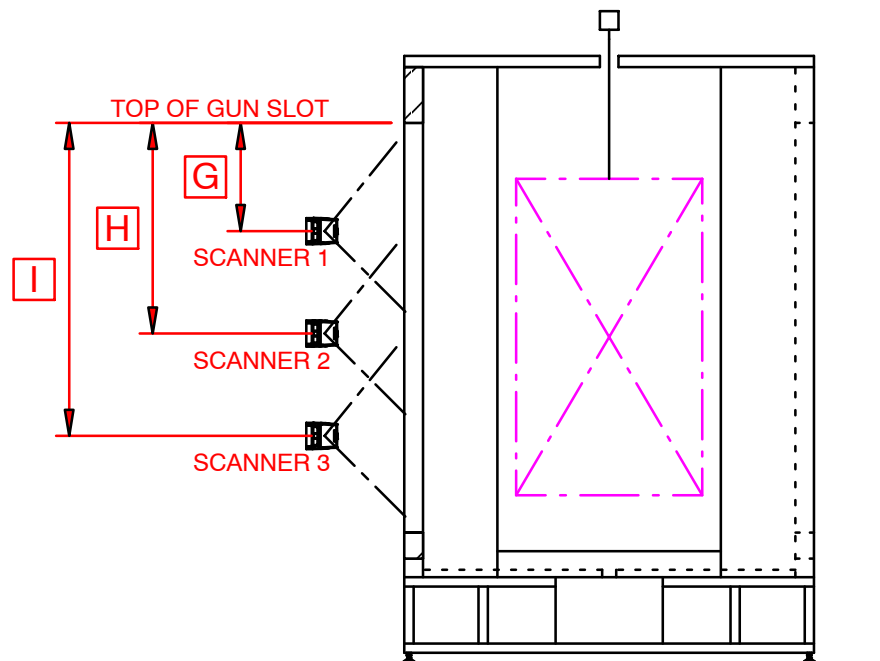

VERTICAL ADJUSTMENTS		
<b>G</b>	Scanner 1 vertical height adjust	<b>100</b> mm
<b>H</b>	Scanner 2 vertical height adjust	<b>500</b> mm
<b>I</b>	Scanner 3 vertical height adjust	<b>900</b> mm
<b>G</b>	Scanner 4 vertical height adjust	<b>100</b> mm
<b>H</b>	Scanner 5 vertical height adjust	<b>500</b> mm
<b>I</b>	Scanner 6 vertical height adjust	<b>900</b> mm

Figure 58 Vertical Adjustments

# Appendix A – System Dimensions(contd)

## Horizontal Adjustments

**NOTE:** Figures shown are examples

In the scenario shown below, make the distance negative  
 If the gun is behind the scanner, then make the dimension positive

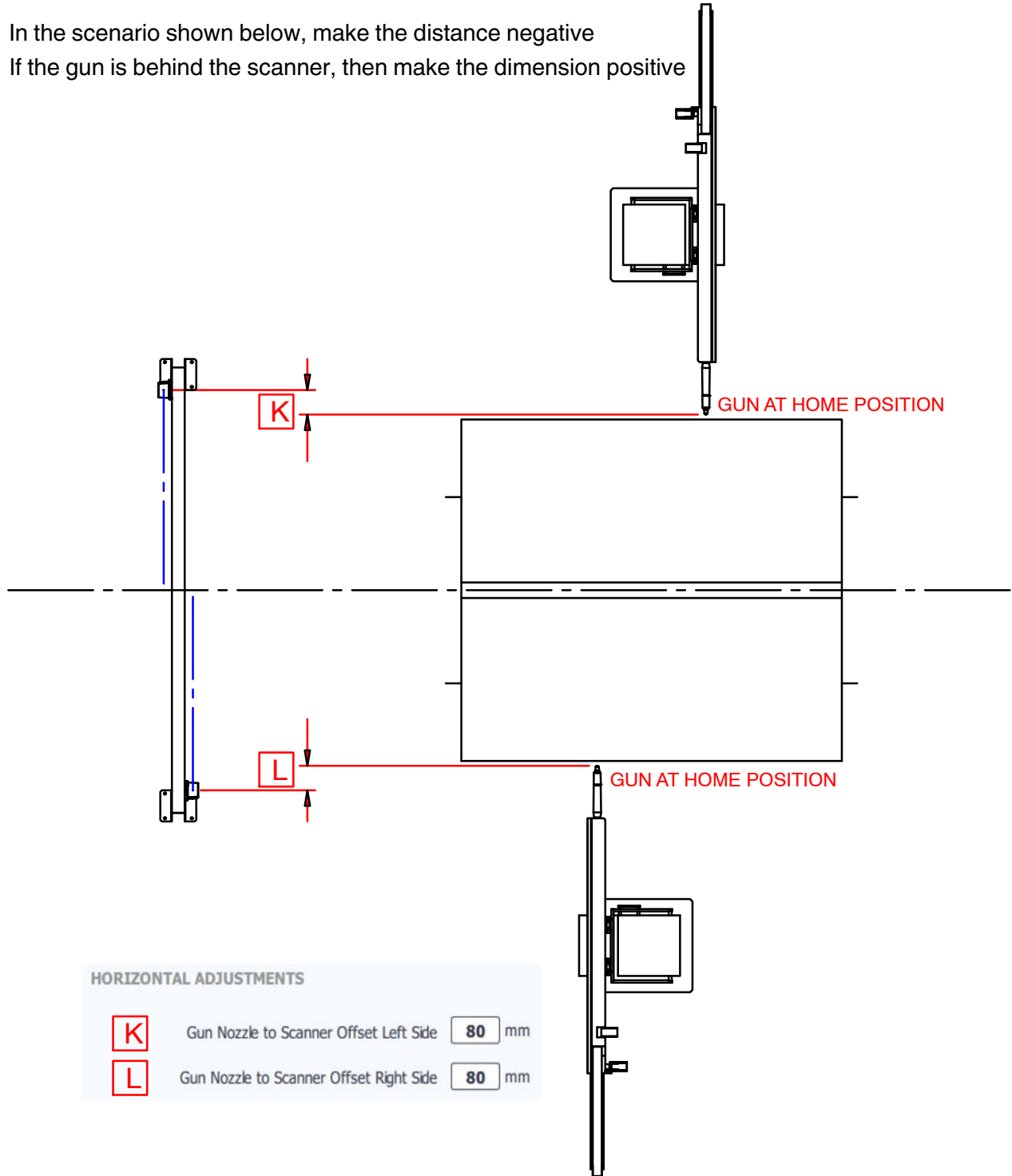

Figure 59 Horizontal Adjustments

## Appendix A – System Dimensions(contd)

### Right Side Valid Scanning Zone

**NOTE:** Figures shown are examples

For value N, it may be necessary to measure beyond the centreline. It must reflect the distance to the point of the product to be coated.

See example (1) below.

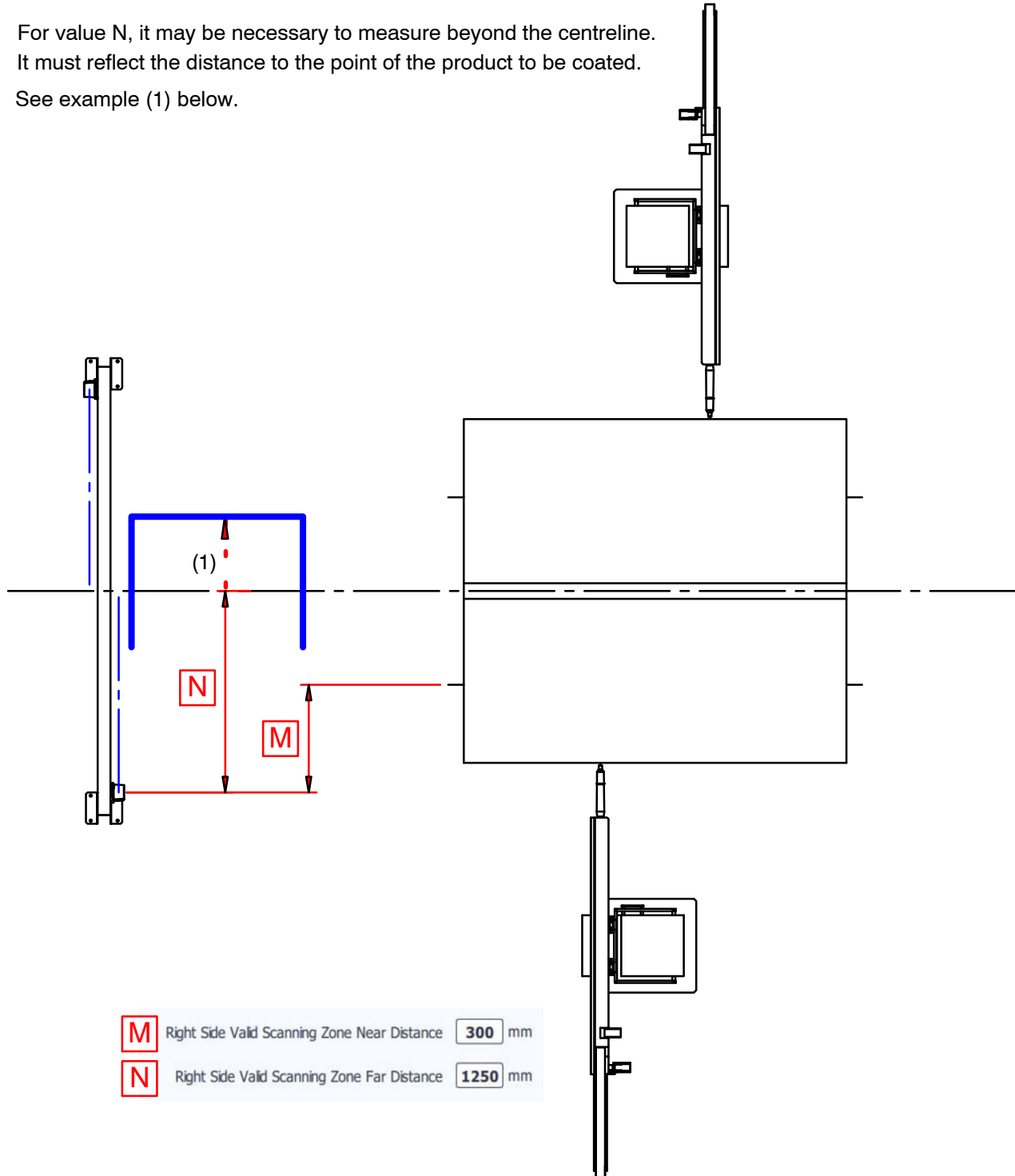

Figure 60 Right Side Valid Scanning Zone

## Appendix A – System Dimensions(contd)

### Left Side Valid Scanning Zone

NOTE: Figures shown are examples

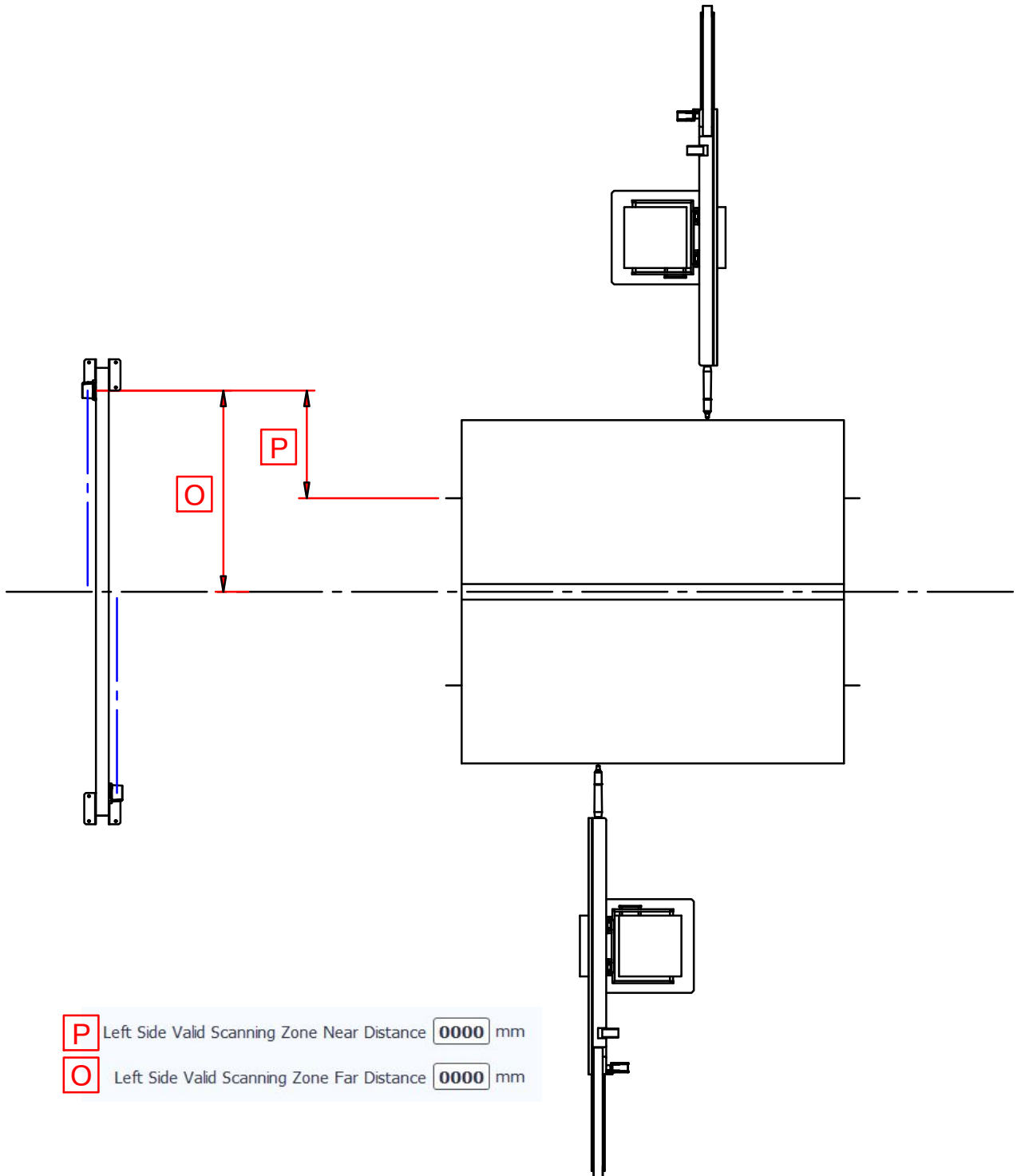

Figure 61 Left Side Valid Scanning Zone