

Econo-Coat[®] **Batch and Conveyor Booths**

Customer Product Manual

Part 334672E02

Issued 7/09

**For parts and technical support, call the Industrial Coating
Systems Customer Support Center at (800) 433-9319 or
contact your local Nordson representative.**

This document is subject to change without notice.
Check <http://emanuals.nordson.com> for the latest version.



Previous Generation

Contact Us

Nordson Corporation welcomes requests for information, comments, and inquiries about its products. General information about Nordson can be found on the Internet using the following address:
<http://www.nordson.com>.

Address all correspondence to:

Nordson Corporation
Attn: Customer Service
555 Jackson Street
Amherst, OH 44001

Notice

This is a Nordson Corporation publication which is protected by copyright. Original copyright date 2001. No part of this document may be photocopied, reproduced, or translated to another language without the prior written consent of Nordson Corporation. The information contained in this publication is subject to change without notice.

Trademarks

Econo-Coat, Nordson, and the Nordson logo are registered trademarks of Nordson Corporation.

Previous Generation

Table of Contents

Safety	1-1
Introduction	1-1
Qualified Personnel	1-1
Intended Use	1-1
Regulations and Approvals	1-2
Personal Safety	1-2
Fire Safety	1-2
Grounding	1-3
Action in the Event of a Malfunction	1-4
Disposal	1-4
Description	2-1
Booth Overview	2-1
Booth Configurations	2-1
Collector Module	2-2
Electrical Panel	2-3
Powder System Operation	2-5
Installation	3-1
Guidelines	3-1
Delivery	3-1
Preparation	3-2
Clearances	3-2
Unpacking	3-3
Canopy Assembly	3-3
Cartridge Filter Installation	3-4
Final Filter Installation	3-6
Pneumatic Connections	3-7
Electrical Connections	3-7
Mounting the Electrical Panel	3-7
Wiring Connections	3-8
Optional Remote Device Power	3-9
Optional Fire Detection System	3-9
EC1001 Single-Phase Electrical Panel Schematic	3-10
Single Phase Electrical Panel	3-11
Three-Phase Electrical Panel Schematic	3-12

Canopy Assembly	4-1
Introduction	4-1
Collector Module Assembly	4-1
Canopy Assembly	4-2
Booth Dimensions	4-5
Batch Booth Dimensions	4-5
Conveyor Booth Dimensions	4-6
Econo-Coat 1001 Batch Booth	4-7
2000-cfm Batch Booth	4-8
3400-cfm Batch Booths	4-10
Model 3401	4-10
Model 3402	4-12
Model 3403	4-14
5300-cfm Batch Booths	4-16
Model 5301	4-16
Model 5302	4-18
Model 5303	4-20
Model 5304	4-22
Model 5305	4-24
Model 5306	4-26
Model 5307	4-28
6000-cfm Batch Booths	4-30
Model 6001	4-30
Model 6002	4-32
Model 6003	4-34
Model 6004	4-36
5300-cfm Conveyor Booths	4-38
Model 5300C1	4-38
Model 5300C2	4-40
Model 5300C3	4-42
Model 5300C4	4-44
Model 5300C5	4-46
Model 5300C6	4-48
Model 5300C7	4-50
Model 5300C8	4-52
Model 5300C9	4-54
6000-cfm Conveyor Booths	4-56
Model 6000C3	4-56
Model 6000C4	4-58
Model 6000C5	4-60
Model 6000C6	4-62
Model 6000C7	4-64
Model 6000C8	4-66
Model 6000C9	4-68
Operation	5-1
Introduction	5-1
Preparation	5-1
Initial Startup	5-2
Daily Startup	5-2
Shutdown	5-3
Maintenance	5-3
Daily Maintenance	5-3
Periodic Maintenance	5-4

Troubleshooting	6-1
Introduction	6-1
Troubleshooting Charts	6-2
Repair	7-1
Introduction	7-1
Cartridge Filter Replacement	7-1
Final Filter Replacement	7-3
Pulse Valve Replacement	7-4
Removing the Pulse Valve	7-4
Installing the Pulse Valve	7-4
Fan and Motor Replacement	7-6
Removing the Fan and Motor	7-6
Installing the Fan and Motor	7-7
Parts	8-1
Introduction	8-1
Using the Illustrated Parts List	8-1
Collector Module	8-2
Collector Module Assembly	8-2
1000-cfm Module	8-2
2000-cfm Module	8-2
3400-cfm Module	8-3
5300-cfm Module	8-3
6000-cfm Module	8-4
Fan Section	8-5
Motor and Fan Assembly	8-7
1000-cfm Motor and Fan Assembly	8-7
2000-cfm Motor and Fan Assembly	8-7
3400-cfm Motor and Fan Assembly	8-7
5300- and 6000-cfm Motor and Fan Assembly	8-7
Common Motor and Fan Assembly Components	8-8
Single-Phase Control Panel	8-9
Single-Phase Control Panel Assemblies	8-9
Single-Phase Control Panel Components – 1001 Booth	8-9
Single-Phase Control Panel Components – 2001 and Larger Booths	8-11
Disconnect	8-12
3-hp Exhauster Motor	8-12
5-hp Exhauster Motor	8-12
10-hp Exhauster Motor	8-12
Three-Phase Control Panel	8-14
Three-Phase Control Panel Assemblies	8-14
Three-Phase Control Panel Components	8-14
Disconnect/Transformers	8-15
3-hp Exhauster Motor	8-15
5-hp Exhauster Motor	8-15
10-hp Exhauster Motor	8-15

Wall Panels	8-17
Galvanized and Stainless Steel Wall Panels	8-17
Polypropylene Wall Panels	8-17
Roof Panels	8-18
Galvanized and Stainless Steel Roof Panels	8-18
Polypropylene Roof Panels	8-18
Brackets	8-18
Hinges	8-19
Roof Supports	8-19
Batch Booth Roof Supports	8-19
6000-cfm Conveyor Booth Roof Support	8-19
Specifications	9-1
Operating Environment	9-1
Normal Design Conditions	9-1
Cross Drafts	9-1
Average Face Velocity	9-1
Part Temperature	9-1
Powder	9-2
Cartridge Filters	9-2
Compressed Air	9-2
Workpiece Clearance	9-3
Electrical Service	9-3
Single-Phase Control Panel	9-3
EC1001 Booth	9-3
EC2001 and Larger Booths	9-3
Three-Phase Control Panel	9-4

Previous Generation

Section 1

Safety

Introduction

Read and follow these safety instructions. Task- and equipment-specific warnings, cautions, and instructions are included in equipment documentation where appropriate.

Make sure all equipment documentation, including these instructions, is accessible to all persons operating or servicing equipment.

Qualified Personnel

Equipment owners are responsible for making sure that Nordson equipment is installed, operated, and serviced by qualified personnel. Qualified personnel are those employees or contractors who are trained to safely perform their assigned tasks. They are familiar with all relevant safety rules and regulations and are physically capable of performing their assigned tasks.

Intended Use

Use of Nordson equipment in ways other than those described in the documentation supplied with the equipment may result in injury to persons or damage to property.

Some examples of unintended use of equipment include

- using incompatible materials
- making unauthorized modifications
- removing or bypassing safety guards or interlocks
- using incompatible or damaged parts
- using unapproved auxiliary equipment
- operating equipment in excess of maximum ratings

Regulations and Approvals

Make sure all equipment is rated and approved for the environment in which it is used. Any approvals obtained for Nordson equipment will be voided if instructions for installation, operation, and service are not followed.

All phases of equipment installation must comply with all federal, state, and local codes.

Personal Safety

To prevent injury follow these instructions.

- Do not operate or service equipment unless you are qualified.
- Do not operate equipment unless safety guards, doors, or covers are intact and automatic interlocks are operating properly. Do not bypass or disarm any safety devices.
- Keep clear of moving equipment. Before adjusting or servicing any moving equipment, shut off the power supply and wait until the equipment comes to a complete stop. Lock out power and secure the equipment to prevent unexpected movement.
- Relieve (bleed off) hydraulic and pneumatic pressure before adjusting or servicing pressurized systems or components. Disconnect, lock out, and tag switches before servicing electrical equipment.
- Obtain and read Material Safety Data Sheets (MSDS) for all materials used. Follow the manufacturer's instructions for safe handling and use of materials, and use recommended personal protection devices.
- To prevent injury, be aware of less-obvious dangers in the workplace that often cannot be completely eliminated, such as hot surfaces, sharp edges, energized electrical circuits, and moving parts that cannot be enclosed or otherwise guarded for practical reasons.

Fire Safety

To avoid a fire or explosion, follow these instructions.

- Do not smoke, weld, grind, or use open flames where flammable materials are being used or stored.
- Provide adequate ventilation to prevent dangerous concentrations of volatile materials or vapors. Refer to local codes or your material MSDS for guidance.
- Do not disconnect live electrical circuits while working with flammable materials. Shut off power at a disconnect switch first to prevent sparking.

- Know where emergency stop buttons, shutoff valves, and fire extinguishers are located. If a fire starts in a spray booth, immediately shut off the spray system and exhaust fans.
- Clean, maintain, test, and repair equipment according to the instructions in your equipment documentation.
- Use only replacement parts that are designed for use with original equipment. Contact your Nordson representative for parts information and advice.

Grounding



WARNING: Operating faulty electrostatic equipment is hazardous and can cause electrocution, fire, or explosion. Make resistance checks part of your periodic maintenance program. If you receive even a slight electrical shock or notice static sparking or arcing, shut down all electrical or electrostatic equipment immediately. Do not restart the equipment until the problem has been identified and corrected.

All work conducted inside the spray booth or within 1 m (3 ft) of booth openings is considered within a Class 2, Division 1 or 2 Hazardous location and must comply with NFPA 33, NFPA 70 (NEC articles 500, 502, and 516), and NFPA 77, latest conditions.

- All electrically conductive objects in the spray areas shall be electrically connected to ground with a resistance of not more than 1 megohm as measured with an instrument that applies at least 500 volts to the circuit being evaluated.
- Equipment to be grounded includes, but is not limited to, the floor of the spray area, operator platforms, hoppers, photoeye supports, and blow-off nozzles. Personnel working in the spray area must be grounded.
- There is a possible ignition potential from the charged human body. Personnel standing on a painted surface, such as an operator platform, or wearing non-conductive shoes, are not grounded. Personnel must wear shoes with conductive soles or use a ground strap to maintain a connection to ground when working with or around electrostatic equipment.
- Operators must maintain skin-to-handle contact between their hand and the gun handle to prevent shocks while operating manual electrostatic spray guns. If gloves must be worn, cut away the palm or fingers, wear electrically conductive gloves, or wear a grounding strap connected to the gun handle or other true earth ground.
- Shut off electrostatic power supplies and ground gun electrodes before making adjustments or cleaning powder spray guns.
- Connect all disconnected equipment, ground cables, and wires after servicing equipment.

Action in the Event of a Malfunction

If a system or any equipment in a system malfunctions, shut off the system immediately and perform the following steps:

- Disconnect and lock out electrical power. Close pneumatic shutoff valves and relieve pressures.
- Identify the reason for the malfunction and correct it before restarting the equipment.

Disposal

Dispose of equipment and materials used in operation and servicing according to local codes.

Previous Generation

Section 2

Description

Booth Overview

Booth Configurations

Refer to Table 2-1 for a list of the standard booth configurations.

NOTE: The 2000-cfm batch booth is only available with a polypropylene canopy. All configurations of the 1000, 3400-, 5300-, and 6000-cfm booths are available with either galvanized or stainless steel canopies.

The booths easily assemble with pre-punched stainless or galvanized steel panels and brackets that fasten together. The roof panels have clear plastic windows to allow overhead lighting into the booth. Polypropylene roof panels on conveyor booths allow overhead lighting into the booth.

Table 2-1 Booth Configurations

Booth	Standard Configurations
1000-cfm Batch	1
2000-cfm Batch	1
3400-cfm Batch	3
5300-cfm Batch	7
5300-cfm Conveyor	9
6000-cfm Batch	4
6000-cfm Conveyor	7

Collector Module

See Figure 2-1.

The collector module is made up of two sections: a fan section and a filter section.

The fan section consists of

- a final filter differential pressure gauge (2),
- an air manifold (3),
- reverse pulse (blowdown) valves (4),
- final filters (6), and
- exhaust fan with motor (7).

The filter section contains the primary high-efficiency cartridge filters (5) which capture the powder overspray. An electrical panel (1) is mounted on the side.

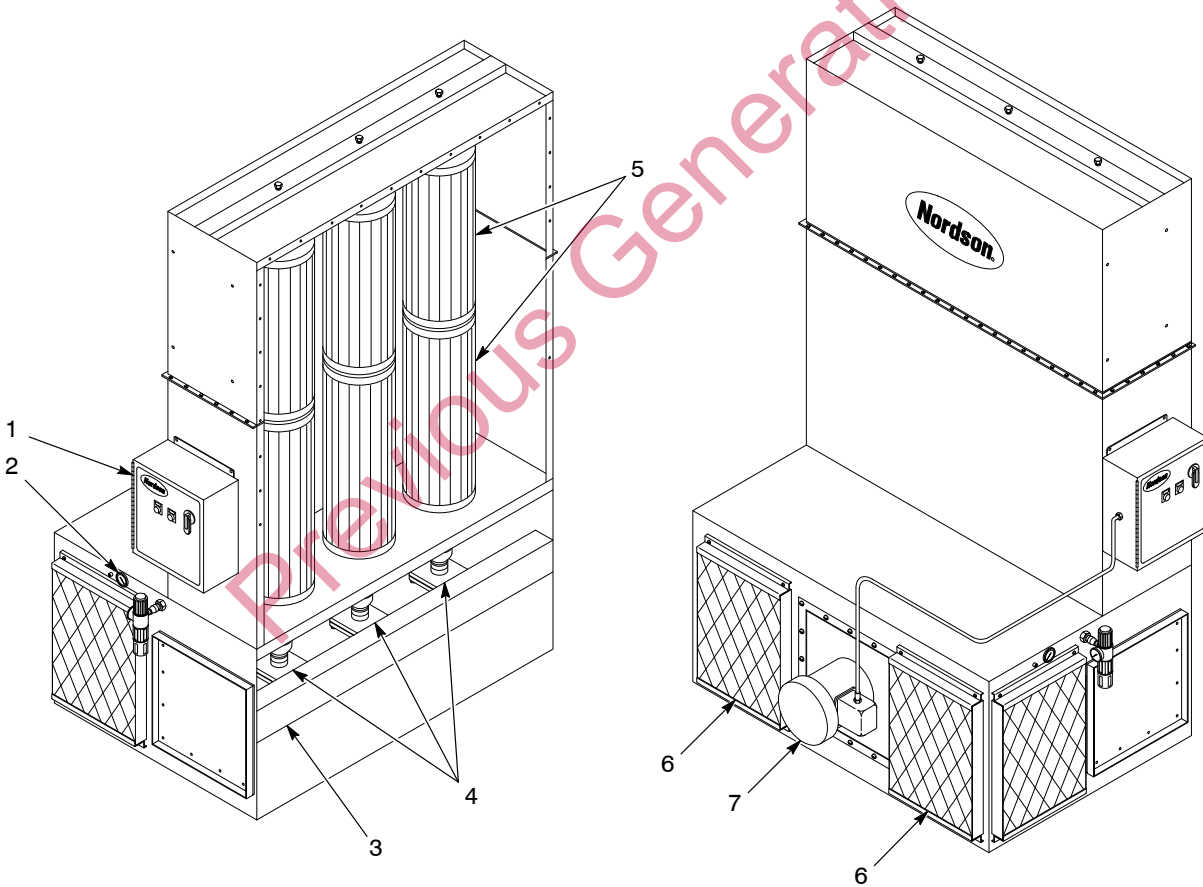

Figure 2-1 Collector Module (Typical)

- | | | |
|--------------------------------|----------------------|------------------|
| 1. Electrical panel | 4. Pulse valves | 6. Final filters |
| 2. Differential pressure gauge | 5. Cartridge filters | 7. Fan motor |
| 3. Air manifold | | |

Electrical Panel

The electrical panel contains basic system controls and pulse valve solenoids. The booth power supply is interlocked with the differential pressure switch and automatically shuts down the exhaust fan if the final filters become clogged.

NOTE: Econo-Coat electrical panels are UL 508 listed. The UL label is located inside of the electrical panel enclosure.

Refer to Table 2-2 and Figure 2-2.

Table 2-2 Control Panel

Item	Control	Function
1	Main disconnect switch	Turns on or off electrical power to the control panel
2	EXHAUSTER STOP button	Shuts down the exhauster fan; does not shut down power to the control panel
3	EXHAUSTER START button and indicator	Starts the exhauster fan and indicates system power is on
4	Pulse valve off timer	Sets time between cartridge filter pulses Adjustment range is 8–180 seconds
5	Pulse valve on timer	Sets time the pulse valves remain open after triggering Adjustment range is 0.05–0.5 seconds
6	Pulse valve LEDs	Indicates, when lit, which pulse valves are activated
7	Solenoid valves	Signal the pulse valves to direct air through the cartridge filters when triggered by the timer board
8	Final filter pressure switch	Monitors the pressure drop across the final filters. At 3 in. wc, the switch opens and automatically shuts down the exhaust fan.

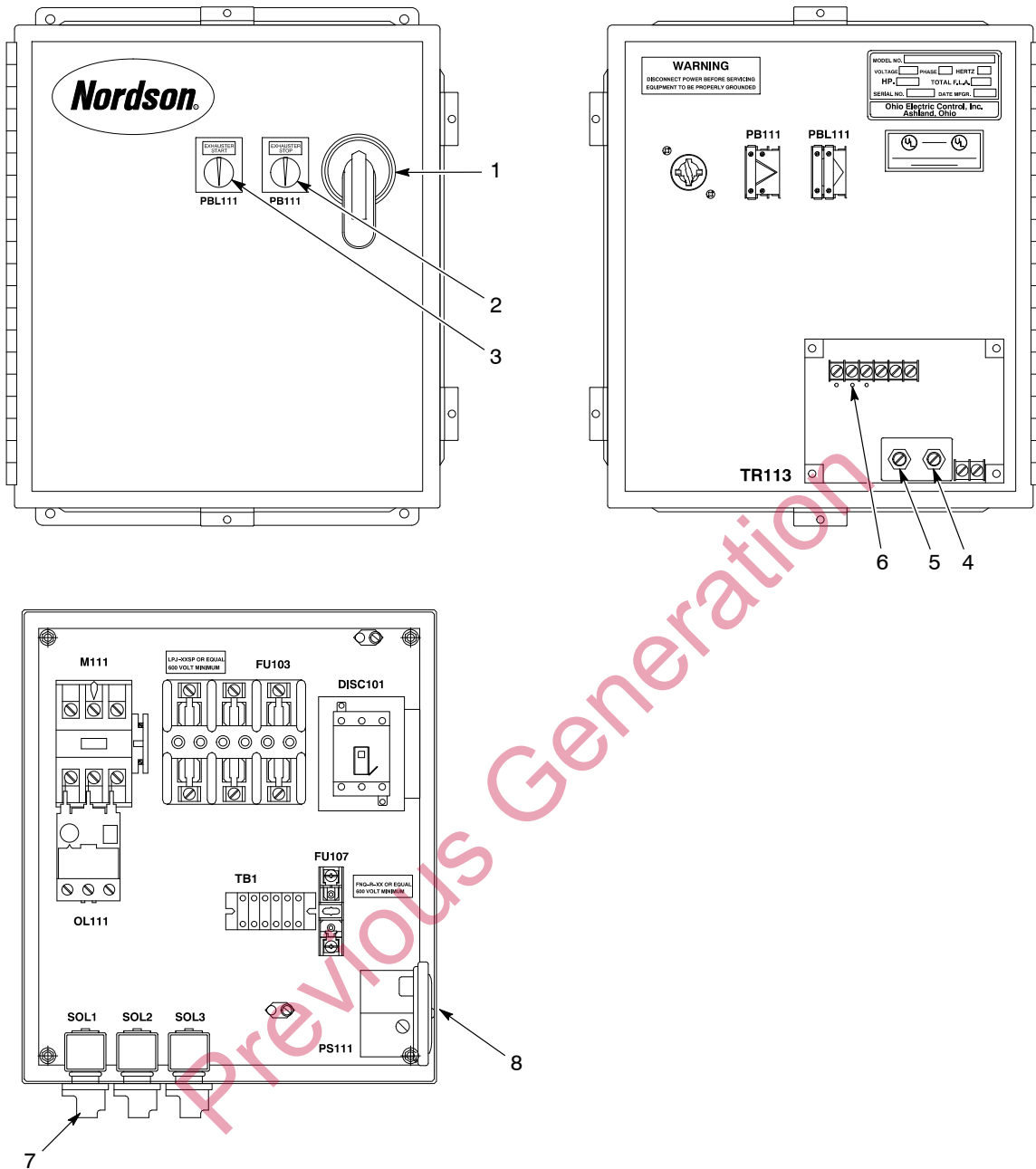

Figure 2-2 Electrical Panel (Typical)

Powder System Operation

Powder is fluidized in a feed hopper by compressed air diffused through a porous membrane called a fluidizing plate. The fluidized powder is supplied to the spray gun by a venturi-type powder pump operating on compressed air. A high-voltage, low-amperage power supply generates an electrostatic field around an electrode at the spray end of the gun. Powder particles sprayed through this field are charged and are attracted to the grounded parts suspended within the booth.

See Figure 2-3. The booth exhaust fan draws spray room air through the booth and cartridge filters and returns it to the spray room through the final filters. Oversprayed powder is collected by the cartridge filters. The air flow prevents sprayed powder from contaminating the spray room.

The solenoid valves in the electrical panel are sequentially energized by the timer board, activating the pulse valves. Reverse pulses of air are directed through the center of the cartridge filters, blowing the collected powder off the filter media. The powder falls into the booth, where it can be collected for disposal.

A differential pressure gauge on the collector module and a pressure switch in the electrical panel monitor the pressure drop across the final filters. If powder leaks past the cartridge filters, the final filters start to clog, and the pressure drop increases. At 3 in. wc the pressure switch shuts off the exhaust fan.

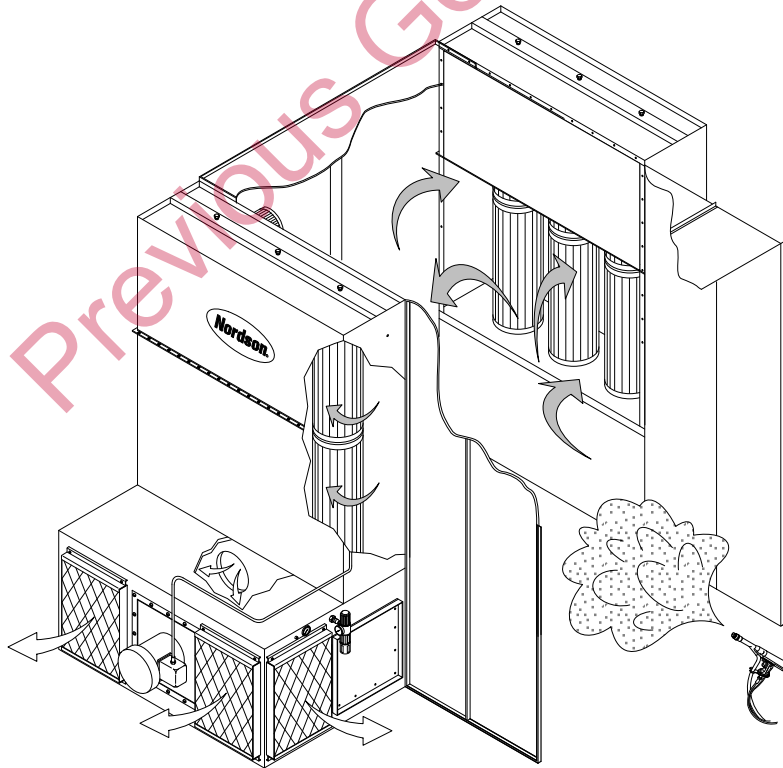

Figure 2-3 Booth Operation (Typical Batch Booth Shown)

Previous Generation

Section 3

Installation



WARNING: Allow only qualified personnel to perform the following tasks. Follow the safety instructions in this document and all other related documentation.

Guidelines

Delivery

Perform the following tasks when the booth is delivered to the installation site.

- Clear the area of all obstructions.
- Provide a secured, indoor storage area for equipment.
- Clear the area leading from the delivery site to the installation site. Make sure that there is sufficient clearance for all equipment to pass through.
- Take inventory of all equipment. Make sure that you have all of the materials listed on the packing slip.

NOTE: Any changes to the order requested during the installation may result in additional charges to the buyer.

Preparation

Perform the following tasks before installing the booth.

- Obtain any necessary local or state permits.

NOTE: Compliance with local, state, and national codes including NFPA Bulletin 33 and buyer's insurance is the responsibility of the buyer.

- Make sure that the installation area has a level, class-B floor.
- Make any building alterations to meet local, state, and national codes in the powder coating room.
- Install sprinkler heads as required by your insurance carrier or local, state, and national codes.
- Make sure that you have sufficient electrical service for installation equipment at the installation site.
- If applicable, make sure that an air conditioning system is installed and operational.
- If applicable, install the conveyor throughout the entire paint area. The conveyor and its hangers must be built and tested at the site before the booth is assembled.
- Provide trash bins and off-site disposal for refuse, skids, and crating.

Clearances

Each booth assembly drawing shows its specific dimensions. The installation area should have ample floor space for coating operations and service. The floor should be level. Refer to the *Canopy Assembly* section.

NOTE: There must be at least 1 m (3 ft) of clearance between the final filters and any wall or other object to allow free air flow.

Unpacking

Econo-Coat booths are shipped unassembled. The following major booth components are shipped in a crate:

- wall panels
- brackets
- roof panels
- roof supports (if used)

The following components are shipped on a pallet:

- fan section(s)
- filter section(s)
- electrical panel

Follow these steps to unpack your Econo-Coat booth parts.

1. Remove the packaging and lay out the panels, brackets, and roof supports (if used) in a clean area. Remove the electrical panel, fan section(s), and filter section(s) from the pallet(s). Set the roof panels, cartridge filters, and final filters aside.
2. Sort the panels and brackets by size and usage, according to the bill of materials and assembly drawings for your booth.

NOTE: Do not remove the protective plastic film from the panels until you are ready to install them.

3. Inspect each component for damage. Document any damage that you find and report it to both the carrier and your Nordson representative.

Canopy Assembly

Refer to the *Canopy Assembly* section for instructions for assembling the canopy. Follow the drawings for your booth configuration, as well as the instructions for assembling the canopy, roof supports, and collector modules.

Cartridge Filter Installation



CAUTION: Use only Nordson-approved cartridge filters. Using unapproved filters may cause equipment damage and void factory warranties.

There are two types of cartridge filters:

- **Flow-Through:** These filters have a large hole on both ends.
- **Closed-End:** These filters have a large hole on one end only.

Use the following procedure to install the cartridge filters into the collector module.

See Figure 3-1.

1. Install the push plates using the following steps:
 - a. Thread the push plate bolt (1) through the top panel.



CAUTION: Do not install the first hex nut onto the push plate bolt more than 25.4 mm (1 in.). The hex nuts are self-locking and cannot be loosened after they have been installed.

- b. Install one of the supplied $\frac{1}{2}$ -13 hex nuts (2) onto the push plate bolt as shown. Do not thread the hex nut more than 25.4 mm (1 in.) from the end of the push plate bolt.
 - c. Install the push plate (3) onto the push plate bolt.
 - d. Install another $\frac{1}{2}$ -13 hex nut (4) after the push plate. Leave a 1.6 mm ($\frac{1}{16}$ in.) gap between the lower hex nut and the push plate.
2. Remove the cartridge filters from their cartons and inspect them for damage. Do not install damaged filters.

NOTE: The 1000 and 2000-cfm batch booths do not use flow-through cartridge filters. Only one or two closed-end cartridge filters are installed, with the open end toward the fan section.

3. Align the flow-through cartridge filter (6) over the large hole in the fan section. Push the bottom of the cartridge filter against the alignment pins.
4. Set the closed-end cartridge filter (5) on top of the flow-through cartridge filter. Align the large hole in the closed-end filter with the large hole in the flow-through filter.
5. Center the push plate over the end cap of the closed-end cartridge filter.



CAUTION: Do not over tighten the push plate bolt. Over tightening the nut may cause cartridge filter damage.

6. Tighten the push plate bolt (1) until the cartridge filter gasket is compressed to $\frac{7}{16}$ in.

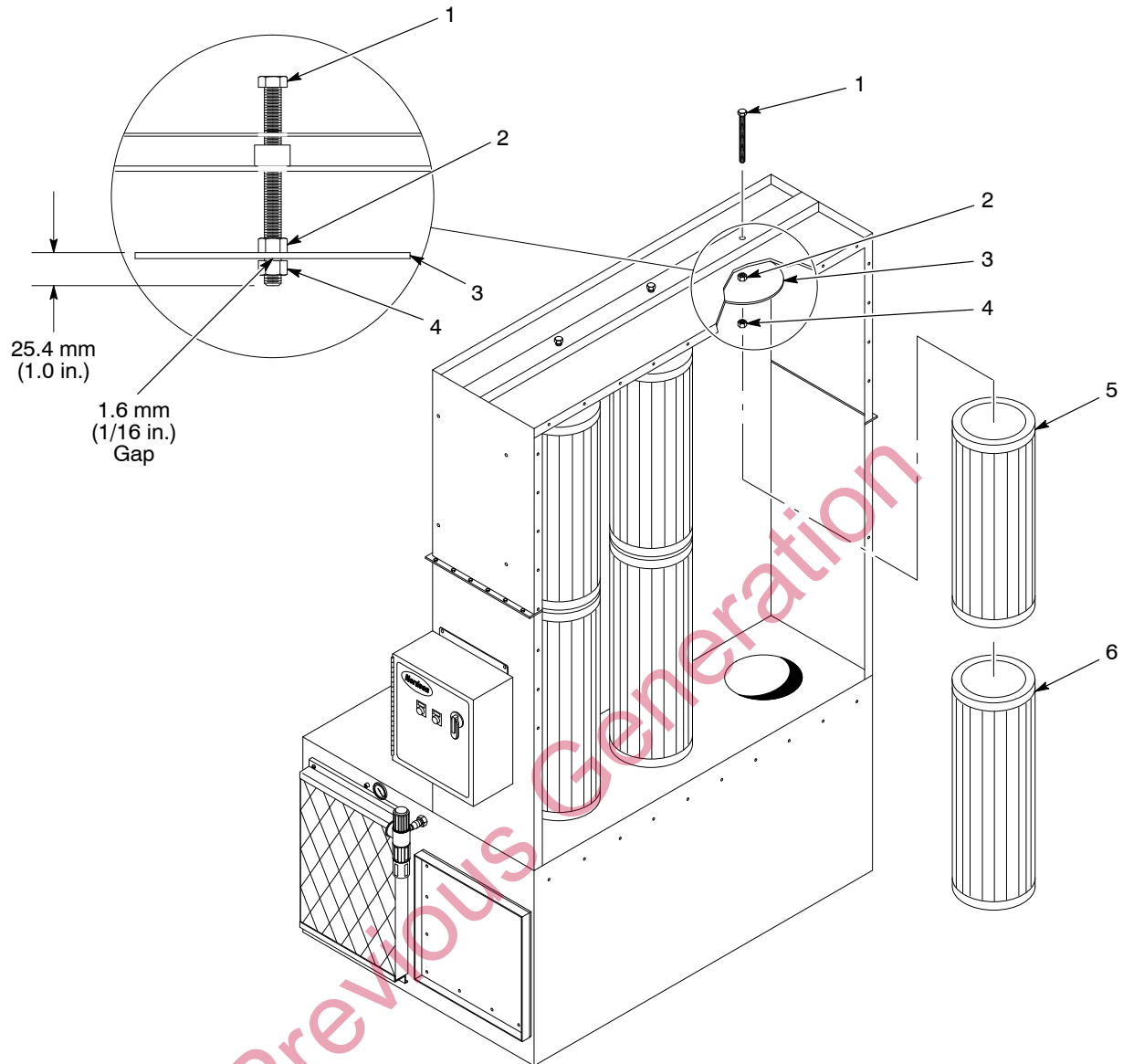

Figure 3-1 Cartridge Filter Installation (Typical)

- | | | |
|--------------------|-------------------|----------------------------------|
| 1. Push plate bolt | 3. Push plate | 5. Closed-end cartridge filter |
| 2. 1/2-13 hex nut | 4. 1/2-13 hex nut | 6. Flow-through cartridge filter |

Final Filter Installation

See Figure 3-2.

1. Remove the upper Z-bracket (1) and loosen the lower Z-bracket (3).
2. Remove the final filter from its carton. Inspect the filter media, frame, and gasket for damage. Do not use damaged filters.
3. Place the final filter (2), gasket side inward, onto the lower Z-bracket and line up the gasket with the edges of the holes in the collector module.
4. Install the upper Z-bracket and tighten both Z-brackets to evenly compress the gasket. Inspect the gasket to make sure that it is properly sealed and aligned.

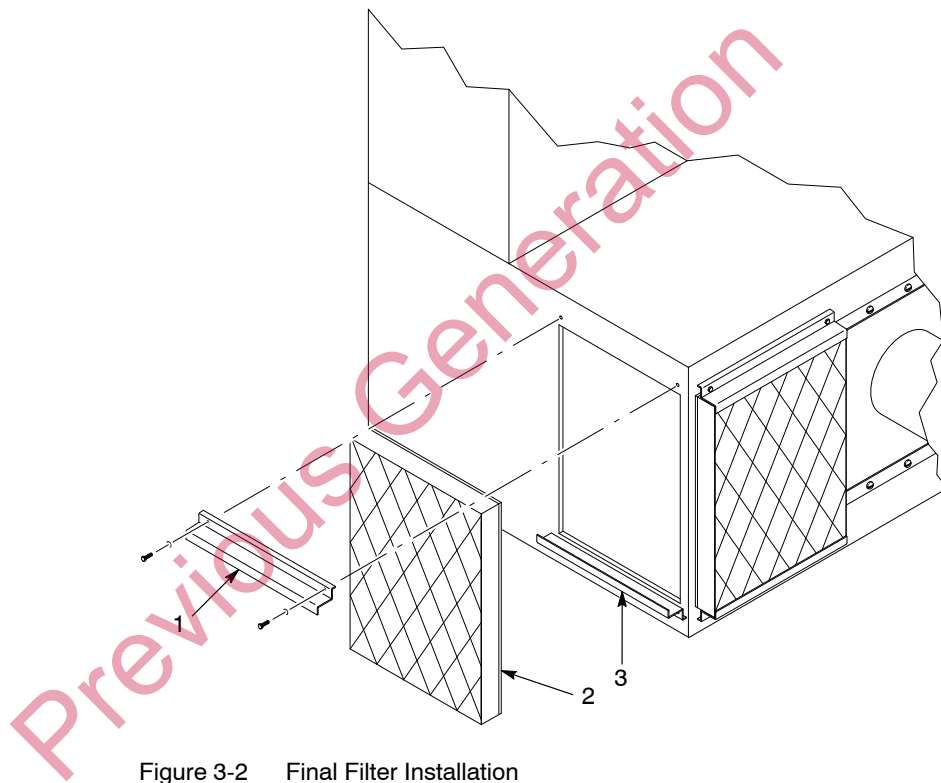

Figure 3-2 Final Filter Installation

- | | |
|--------------------|--------------------|
| 1. Upper Z-bracket | 3. Lower Z-bracket |
| 2. Final filter | |

Pneumatic Connections



WARNING: Do not operate equipment at a pressure greater than the maximum rated working pressure of any component in the system.

Make sure that the following equipment is installed before connecting the compressed air supply to the booth.

- compressed air line within 6 m (20 ft) of each booth
- desiccant-type air dryers
- pressure-relieving ball valve, drop leg, and drain valve on the main air drop

Electrical Connections



WARNING: All phases of installation must comply with all federal, state, and local codes. All work that is located in class 2, divisions 1 and 2 hazardous locations must comply with NFPA code 33, spray application 1995, and NFPA code 70 (especially articles 500, 502, and 516, latest editions).



WARNING: Even with the electrical panel disconnect in the off position, the input terminals at the top of the switch are still live. Do not touch them. Failure to observe this warning could result in serious injury or death.

Use the following procedures to install the electrical components of an Econo-Coat booth.

Mounting the Electrical Panel

See Figure 3-3.

1. Secure the electrical panel (6) to the left-hand side of the filter section with the provided $5/16$ -18 x 1 in. bolts, washers, and nuts (3).



WARNING: Risk of electrical shock. Make sure that all conduit and conduit fittings are liquid tight.

NOTE: Motor wiring, conduit fittings, flexible conduit, and anchor clips are shipped with the booth assembly.

2. Pull the motor wiring (5) through the flexible conduit (4) and connect it to the appropriate motor terminals.
3. Secure the conduit to the motor. Route the conduit to the electrical panel, using the anchor clips to secure the conduit.

Mounting the Electrical Panel (contd)

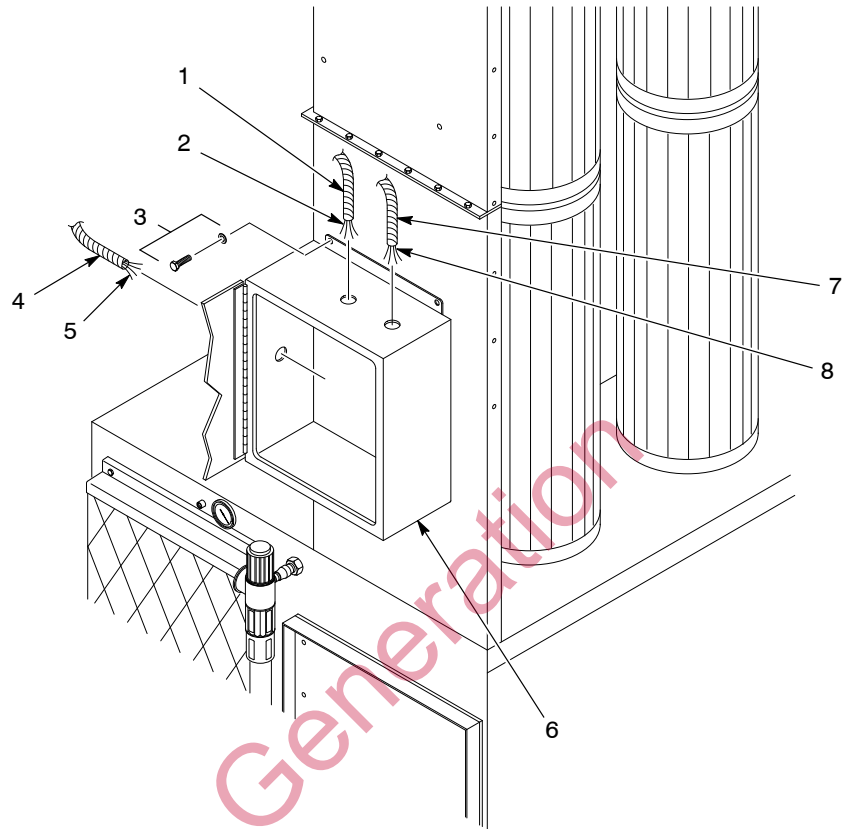

Figure 3-3 Electrical Connections

- | | |
|--|----------------------------|
| 1. Main electrical conduit | 6. Control panel |
| 2. Main electrical wiring | 7. Control circuit conduit |
| 3. $\frac{5}{16}$ -18 bolts, washers, and nuts | 8. Control circuit wiring |
| 4. Flexible conduit | |
| 5. Motor wiring | |

Wiring Connections

Use one of the following schematics when connecting the wiring:

- **Single-Phase Systems:** See Figure 3-4 or 3-5.
- **Three-Phase Systems:** See Figure 3-6.

1. Pull the motor wiring through the knockout in the left side of the control panel and connect it to the appropriate overload (OL111) terminals.
2. Secure the conduit to the control panel.

3. Provide a fused or circuit-breaker protected and lockable voltage source for the main electrical supply.

For Three-Phase Systems: Also provide a 10 amp fused or circuit-breaker protected and lockable 110 volt ac voltage source for the control circuit and remote devices.

4. See Figure 3-3. Pull the main electrical wiring (2) through the appropriate size conduit (1) and connect it to the panel disconnect switch (DISC 101).

For Three-Phase Systems: Pull the control circuit electrical wiring (8) through the appropriate size conduit (7). Connect L1 to the panel disconnect switch AUXILIARY (DISC101A) and NEUTRAL to panel terminal number 1020.

5. Secure the electrical conduit to the control panel.
6. Locate the timer board on the inside door of the control panel. Set the timer board to the following settings:
 - **Off-Pulse Time:** 90 seconds
 - **On-Pulse Time:** 0.07 seconds

Optional Remote Device Power

Run conduit or cord connections through the bottom of the electrical panel and connect to terminals 1130 (110 Vac) and 1020 (NEUTRAL). These terminals provide an exhaust fan interlocked 9 amp voltage supply to optional remotely located devices.

Optional Fire Detection System

NOTE: Fire detection systems are required when automatic or unattended spray operations are performed. Refer to the appropriate fire detection system manual for installation and operating procedures.

Use one of the following schematics when connecting the wiring:

1. Mount the fire detection control panel in a convenient location near the spray booth electrical panel.
2. Run conduit and wiring between the fire detection panel and the spray booth electrical panel.
3. Make the connections as shown in Figures 3-4, 3-5, or 3-6.
4. Remove the factory-installed jumper wire between terminals 1090 and 1110 on the spray booth electrical panel.
5. Connect the conveyor E-stop circuit through terminals 1271 and 1272 to interlock the conveying system and the fire detection system. When a fire is detected the circuit will open and the conveyor will stop.

EC1001 Single-Phase Electrical Panel Schematic

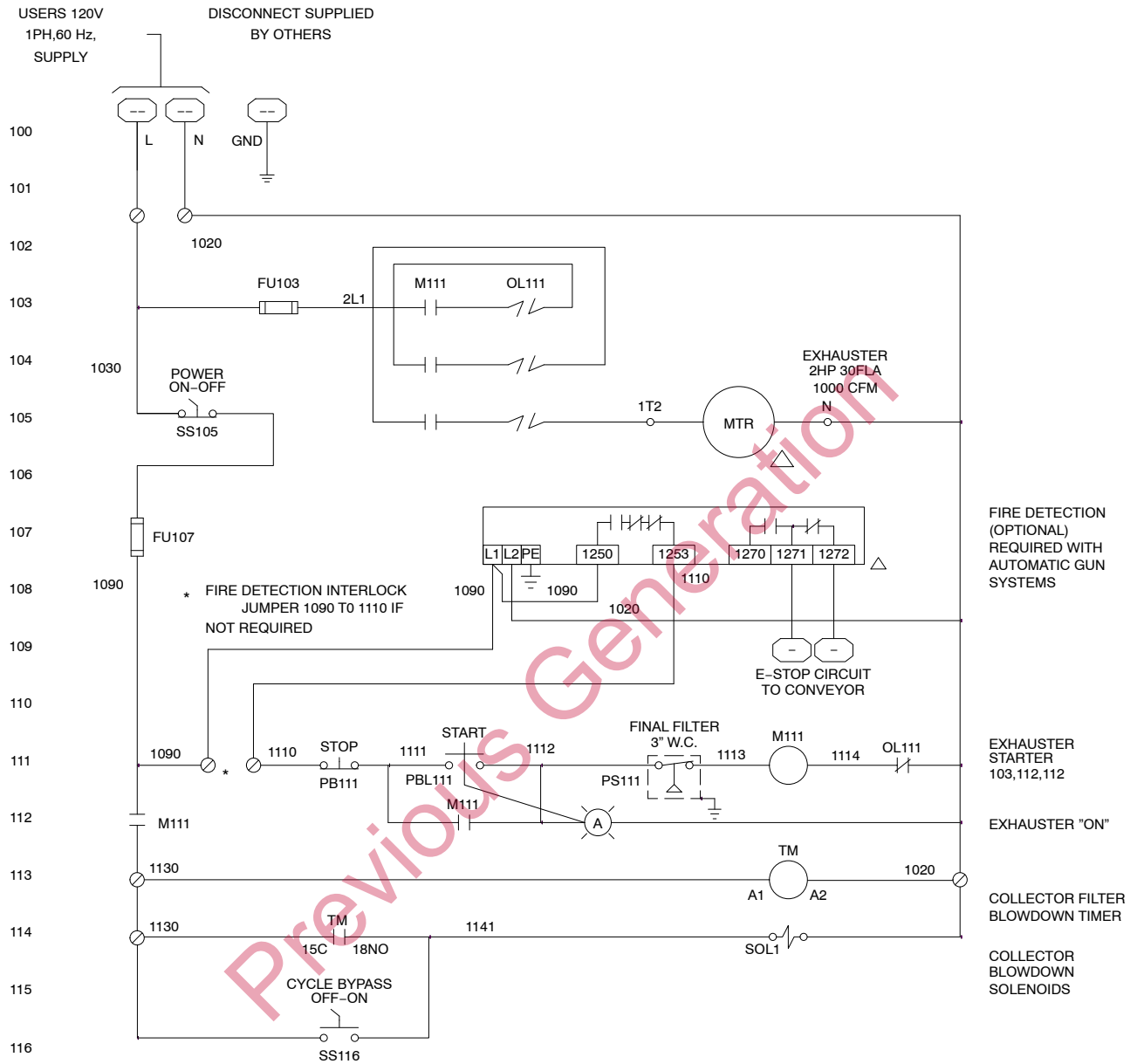

Figure 3-4 EC1001 Single-Phase Electrical Panel Schematic

Single Phase Electrical Panel

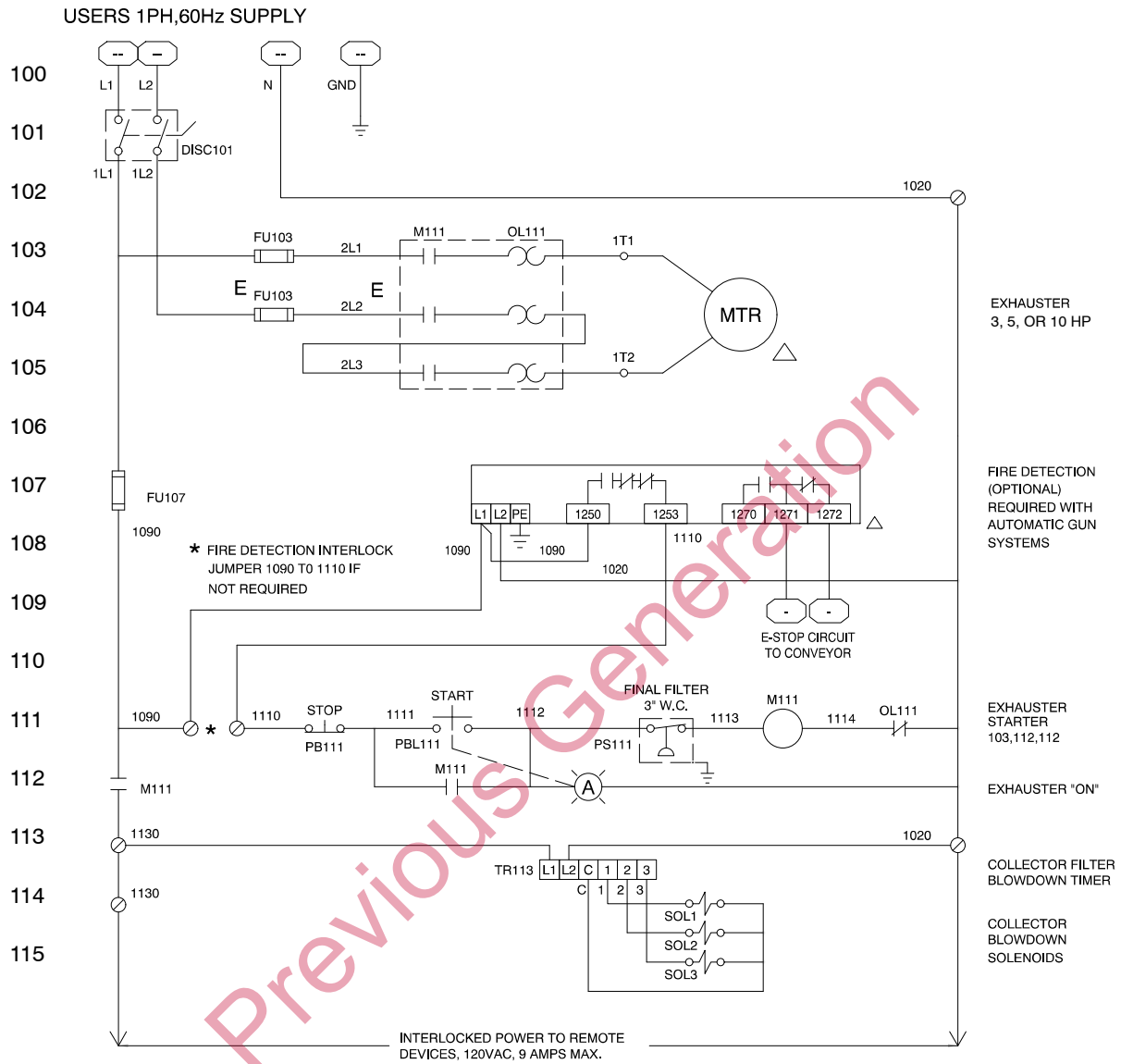

Figure 3-5 Single-Phase Electrical Panel Schematic (EC2001 Booth)

Three-Phase Electrical Panel Schematic

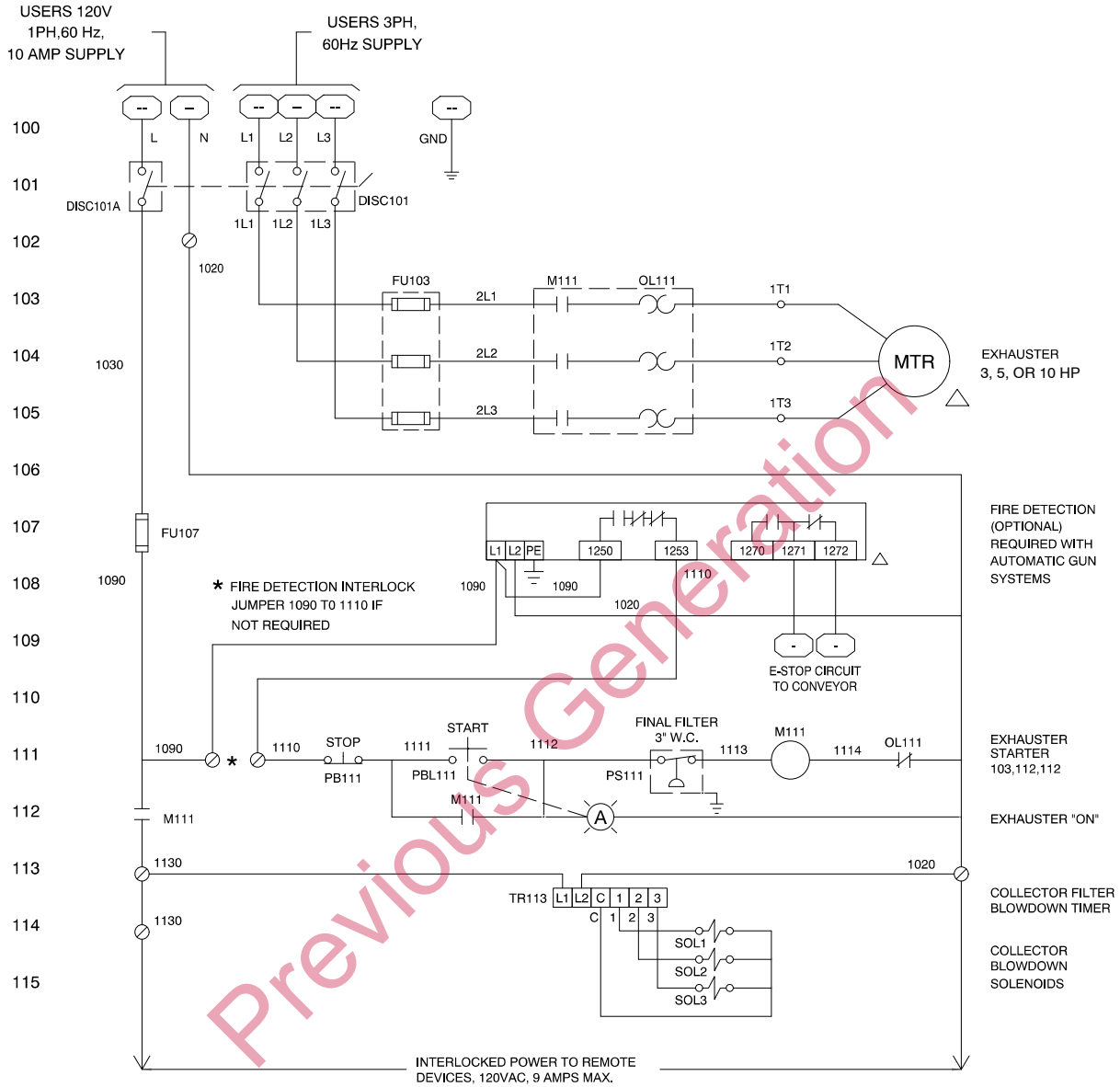

Figure 3-6 Three-Phase Electrical Panel Schematic

Section 4

Canopy Assembly



WARNING: Allow only qualified personnel to perform the following tasks. Follow the safety instructions in this document and all other related documentation.

Introduction

Each booth configuration has specific assembly drawings. Each set of assembly drawings show a series of flat views of the booth component layout. Refer to your booth drawing and bill of materials in this section.



WARNING: Always balance the load when lifting components. Never put stress on flat panels. Do not attempt to lift using covers, doors, cables, or hose connections. Use only lifting equipment with a rated capacity greater than the load. While lifting, make sure all personnel stand clear.

Collector Module Assembly

Use the following procedure to assemble the collector modules.

NOTE: If you are assembling a batch booth that has two collector modules side by side, install the final filters on the collector modules before you move them into position. Refer to *Final Filter Installation* in the *Installation* section.

1. Move the first fan section to the installation site.

NOTE: Make sure that the assembly is squared as you proceed.

2. If your booth has two collector modules, move the second fan section into place.
3. Secure the filter section and top covers to the fan sections using the supplied $\frac{3}{8}$ -16 x 0.75 in. screws and $\frac{3}{8}$ -in. nuts.
4. Seal all filter section seams using the provided caulk. Apply the caulk carefully, making sure that the bead is continuous and has no gaps or voids.

NOTE: Allow 24 hours for the caulk to cure.

Canopy Assembly

NOTE: Each booth configuration uses different sizes of wall panels and brackets. Pay close attention to your bill of materials when assembling your booth.

The items shown on each set of assembly drawings are described in their corresponding bill of materials. The dimensions of each lettered component are listed beneath its corresponding booth model height.

Follow these steps to assemble the canopy:

NOTE: Do not tighten fasteners until the entire booth is assembled and squared.

1. Assemble the wall panels to the collector modules following these guidelines.

- **1000 and 2000-cfm batch booths:** Install the legs and floor panels before assembling the wall panels.

- **3400-, 5300-, and 6000-cfm batch booths:**

See Figure 4-1.

If used, install the roof support legs (3) between the wall panels (4), in locations shown in the batch booth assembly drawings.

NOTE: A batch booth roof support assembly consists of two vertical legs (3) and a horizontal rail (2). Roof supports that are installed against a collector module will only use the horizontal rail. Leave out the two vertical legs.

- **Conveyor booths:** Install the hinges to one pair of C panels below the shorter pair of angle brackets. The hinges allow the C panels to swing open so the operator can enter one end of the conveyor booth. Install the latch between the hinged C panels to keep the panels closed when the booth is operating.
- Seal any gaps between the wall panels and the collector modules with the provided caulk.

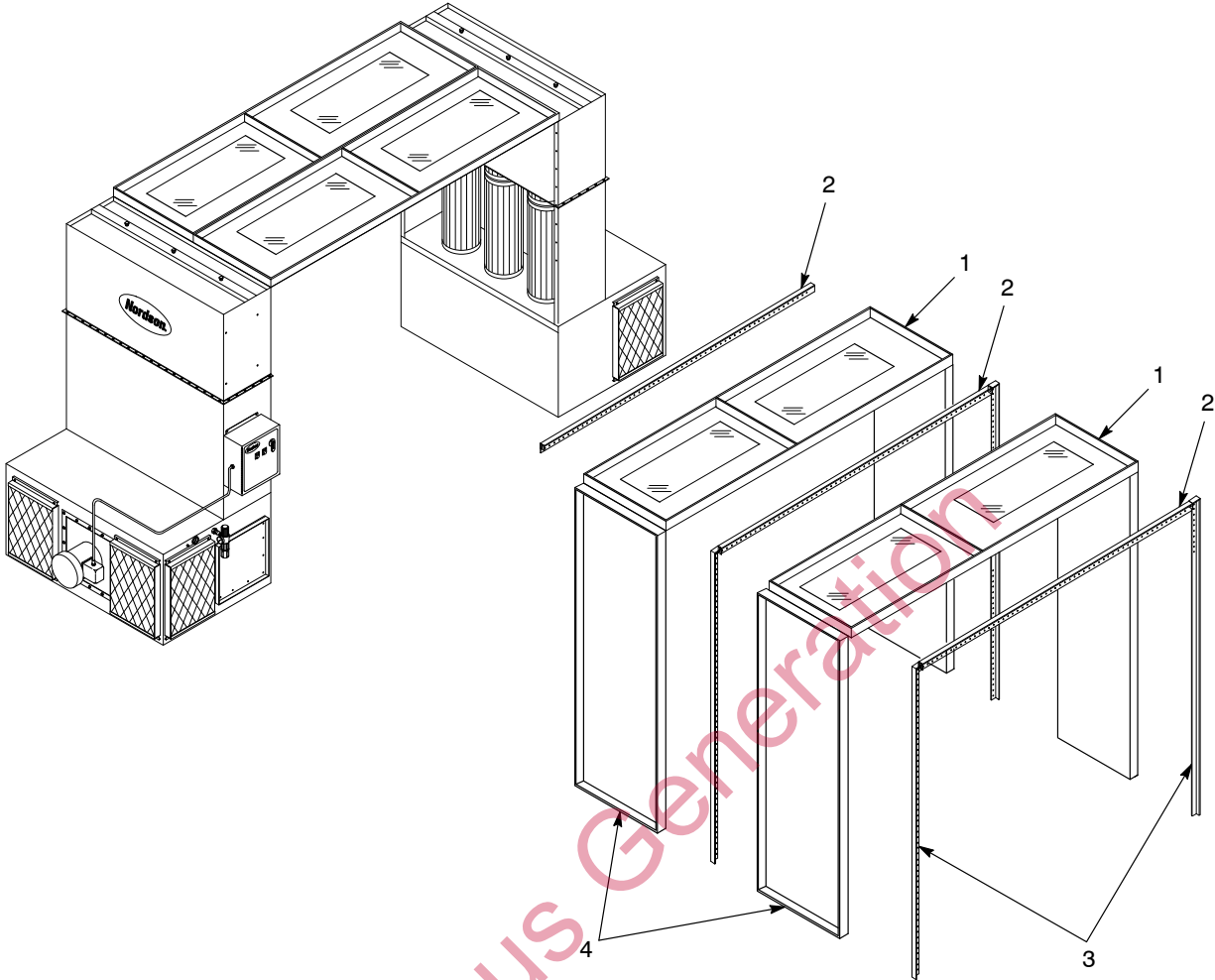

Figure 4-1 Batch Booth Roof Supports (Typical)

- 1. Roof panels
- 2. Horizontal rails
- 3. Support legs
- 4. Wall panels

Canopy Assembly *(contd)*

2. Make sure that the booth assembly is squared before proceeding.
3. See Figure 4-1. Install the roof panels using the following guidelines:
 - **Batch booths:** Assemble the brackets to the top of the wall panels. Install the roof panels (1) as shown in the assembly drawings.
 - **Conveyor booths:** Bolt the roof panels to the top edges of the wall panels.
4. **6000C3–6000C9 conveyor booths only:** To prevent the roof from sagging, install the roof support assembly in the middle of the roof.

See Figure 4-2.

- a. Rest the roof support horizontal tube (2) on top of the conveyor (3).
 - b. Adjust the vertical threaded rods (1).
 - c. Bolt the horizontal ends (4) of the rods to the roof panel flanges (5).
5. When the entire booth is assembled and squared, bolt the wall panels to the floor.

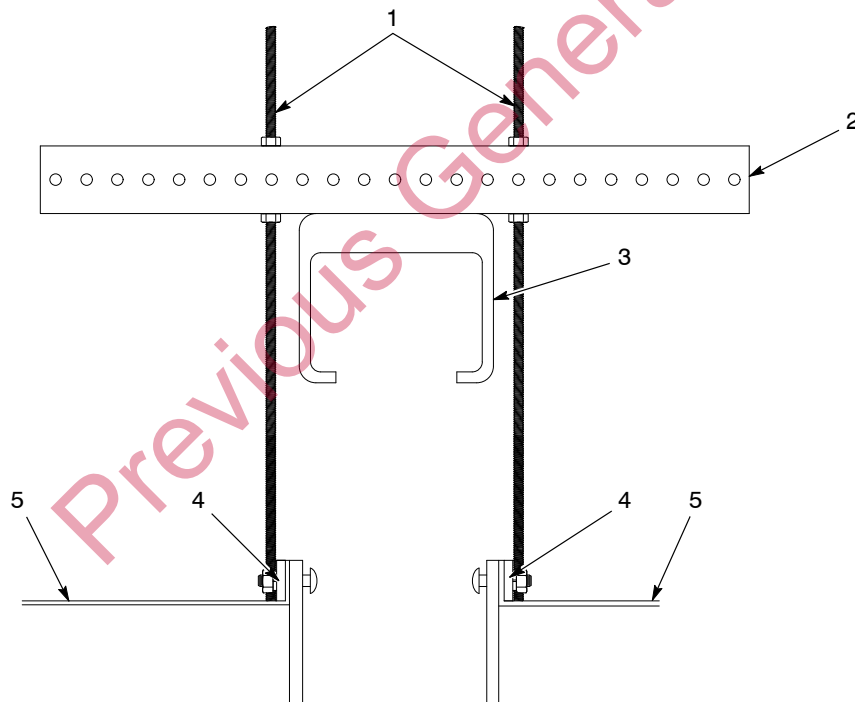

Figure 4-2 6000C3–6000C9 Conveyor Booth Roof Support Installation

- | | | |
|---------------------------|--------------------|----------------|
| 1. Vertical threaded rods | 3. Conveyor | 5. Roof panels |
| 2. Horizontal tube | 4. Horizontal ends | |

Booth Dimensions

Refer to the following tables for the dimensions of the standard booth configurations. Locate your booth assembly drawing and bill of materials and pay close attention to them when assembling your booth. Contact your Nordson representative if you have questions about your booth assembly.

Batch Booth Dimensions

Refer to Table 4-1 for batch booth dimensions.

Table 4-1 Batch Booth Dimensions

Model	Inside Work Area (in.)			Footprint (in.)			Number of Modules
	Height	Width	Depth	Height	Width	Depth	
1000-cfm							
1001	45	30	30	69	40	74.5	1
2000-cfm							
2001	60	60	60	87	69	105	1
3400-cfm							
3401	84	60	60	88	72	108	1
3402	84	108	120	88	205	129	2
3403	96	96	120	99	193	129	2
5300-cfm							
5301	96	84	120	101	87	174	1
5302	96	120	120	101	228	129	2
5303	96	144	120	101	252	129	2
5304	96	168	120	101	179	174	2
5305	108	144	120	112	252	129	2
5306	120	120	120	124	228	129	2
5307	144	96	120	147	204	129	2
6000-cfm							
6001	108	84	120	111	87	174	1
6002	108	168	120	112	276	129	2
6003	120	72	120	121.5	75	174	1
6004	120	144	120	124	252	129	2

Conveyor Booth Dimensions

Refer to Table 4-2 for conveyor booth dimensions.

Table 4-2 Conveyor Booth Dimensions

Model	Inside Work Area (in.)			Footprint (in.)			Part Opening (in.) H x W	Operator Opening (in.) H X W
	Height	Width	Depth	Height	Width	Depth		
5300-cfm								
5300C1	96	60	60	97.5	70	116	60 x 36	72 x 30
5300C2	102	60	60	103.5	70	116	60 x 36	72 x 30
5300C3	108	60	60	109.5	70	116	60 x 36	72 x 30
5300C4	114	60	60	115.5	70	116	60 x 36	72 x 30
5300C5	120	60	60	121.5	70	116	60 x 36	72 x 30
5300C6	126	60	60	127.5	70	116	60 x 36	72 x 30
5300C7	132	60	60	133.5	70	116	60 x 36	72 x 30
5300C8	138	60	60	139.5	70	116	60 x 36	72 x 30
5300C9	144	60	60	145.5	70	116	60 x 36	72 x 30
6000-cfm								
6000C3	108	120	60	109.5	129	116	60 x 30	72 x 30
6000C4	114	120	60	115.5	129	116	60 x 30	72 x 30
6000C5	120	120	60	121.5	129	116	60 x 30	72 x 30
6000C6	126	120	60	127.5	129	116	60 x 30	72 x 30
6000C7	132	120	60	133.5	129	116	60 x 30	72 x 30
6000C8	138	120	60	139.5	129	116	60 x 30	72 x 30
6000C9	144	120	60	145.5	129	116	60 x 30	72 x 30

Econo-Coat 1001 Batch Booth

Use the following illustration to assemble the canopy to the filter section.

1. Bolt the legs to the floor panel, then bolt the floor panel to the filter section.
2. Bolt the side panels to the filter section and floor panel.
3. Bolt the top panel to the side panels and filter section.

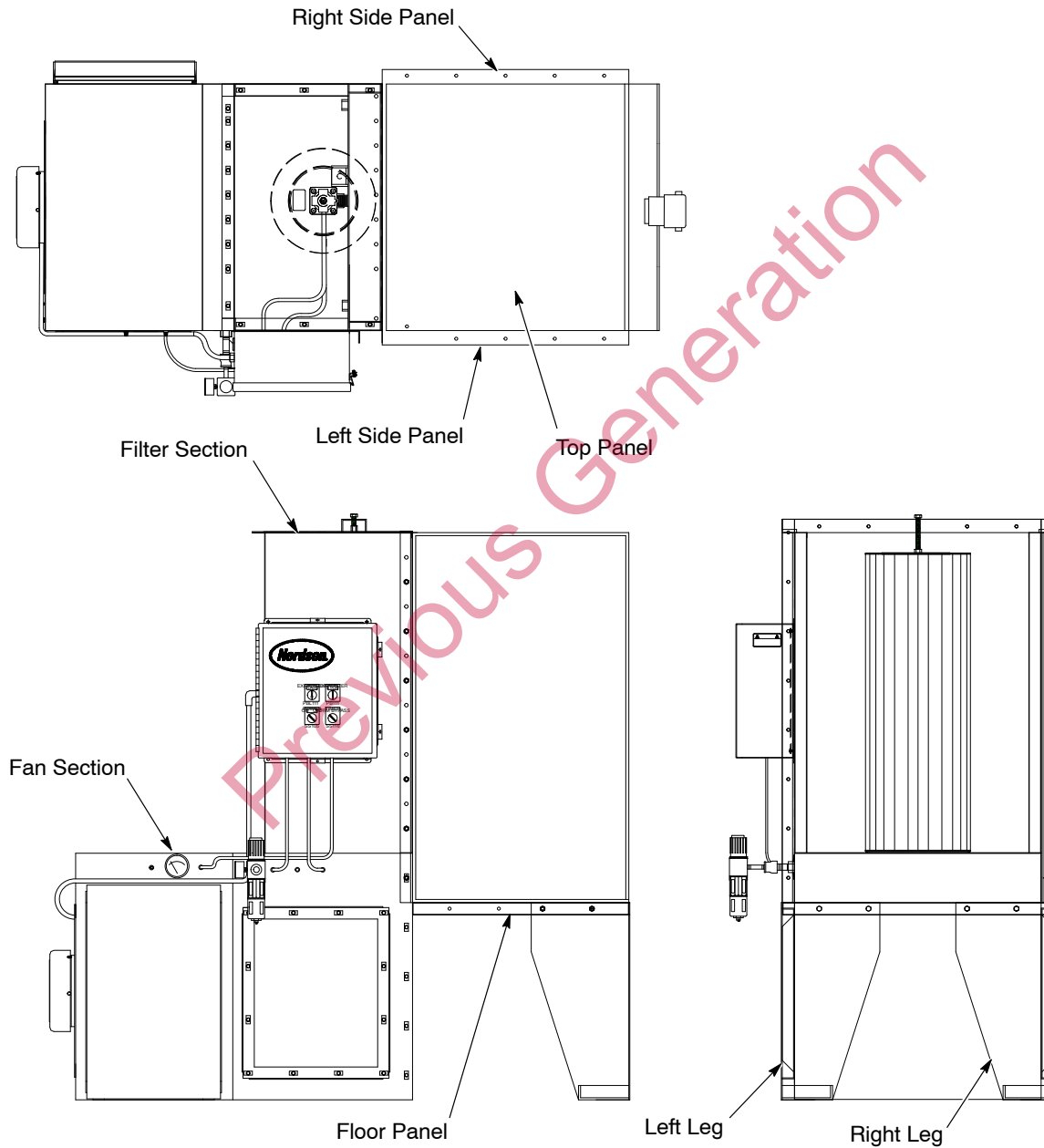

Figure 4-3 Econo-Coat 1001 Assembly Drawing

2000-cfm Batch Booth

Use the following bill of materials and assembly drawing to assemble a 2000-cfm batch booth.

Refer to Table 4-3 and Figure 4-4.

Table 4-3 Model 2000

Item	Description	Dimensions, in.	Quantity
A	Wall panel, side	60 x 60	2
B	Wall panel, back	63 x 18	1
C	Floor panel	63 x 30	2
D	Roof panel	60 x 63	1
E	Support leg	24 x 12	2
F	Bracket	45	2
—	Collector module	70.5 x 63 x 44.2	1

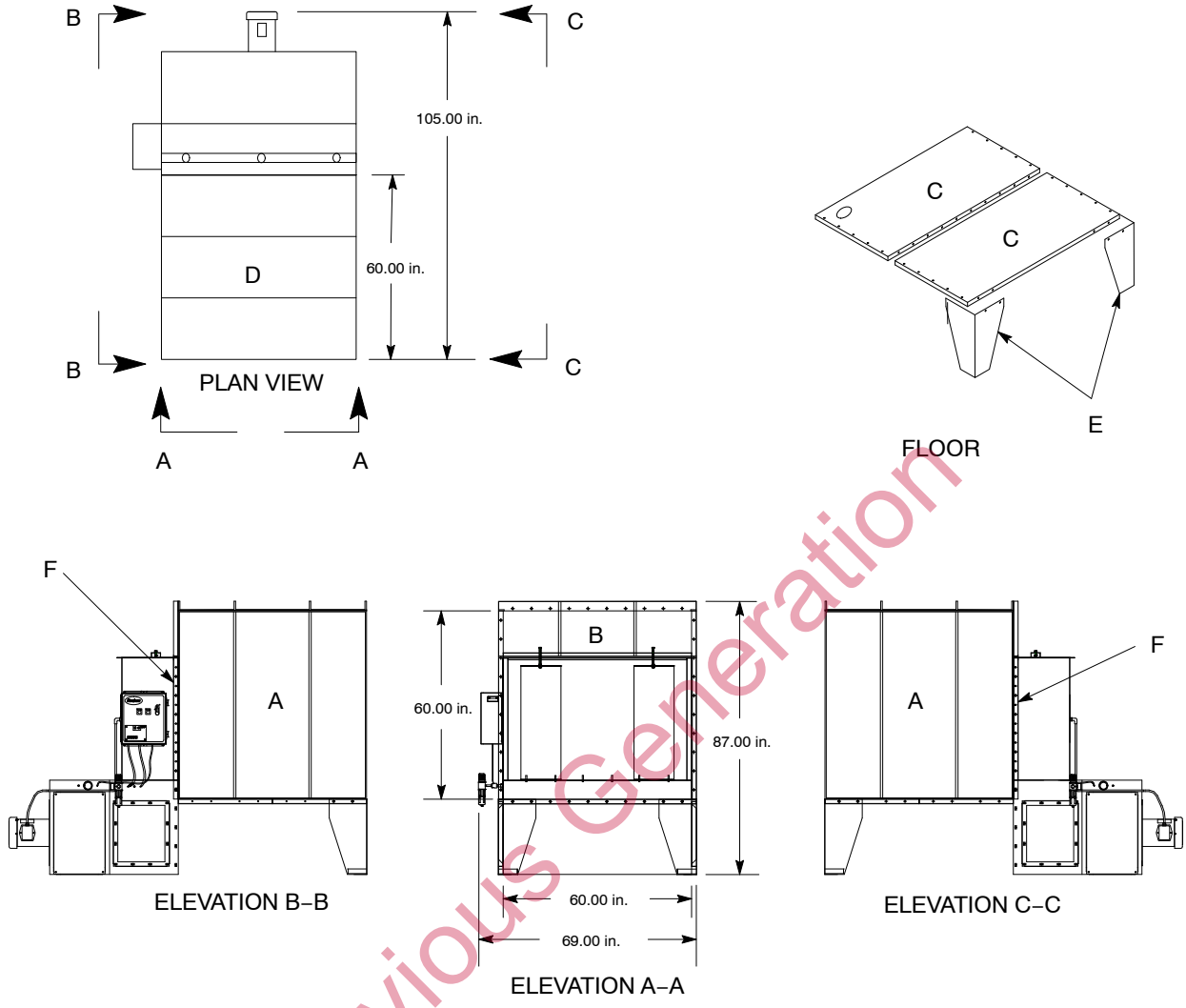

Figure 4-4 Model 2000 Assembly Drawing

3400-cfm Batch Booths

Model 3401

Refer to Table 4-4 and Figure 4-5.

Table 4-4 Model 3401

Item	Description	Dimensions, in.	Quantity
A	Wall panel	84 x 30	4
B	Roof panel	60 x 30	2
C	Bracket	60	3
D	Bracket	84	2
—	Collector module	84.1 x 65.5 x 48.3	1

Previous Generation

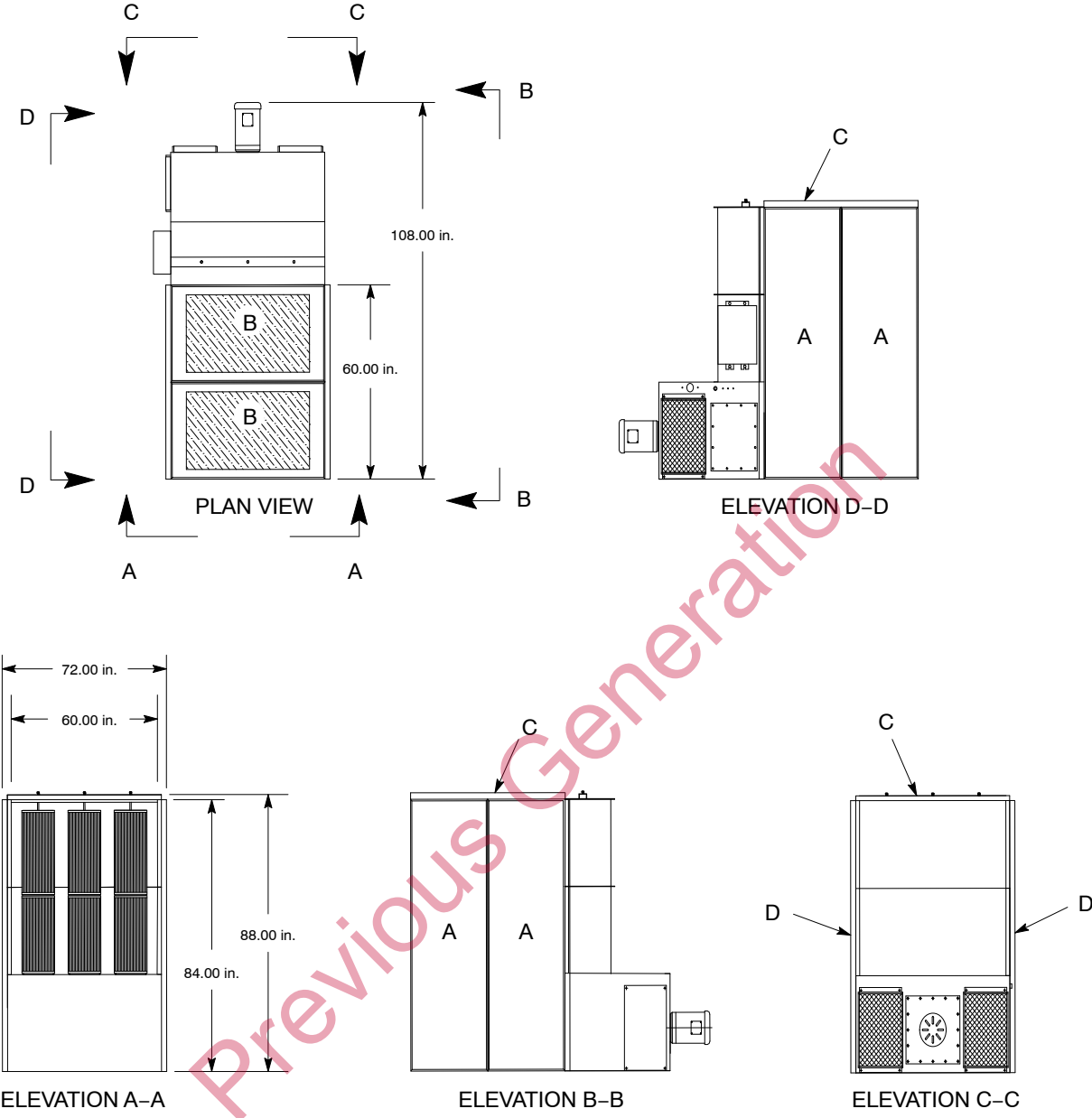

Figure 4-5 Model 3401 Assembly Drawing

Model 3402

Refer to Table 4-5 and Figure 4-6.

Table 4-5 Model 3402

Item	Description	Dimensions, in.	Quantity
A	Wall panel	84 x 30	7
B	Wall panel	84 x 18	1
C	Roof panel	108 x 30	4
D	Bracket	60	5
E	Bracket	84	2
F	Bracket	48	1
G	Roof support	84 x 108	1
H	Horizontal roof support	108	1
—	Collector module	84.1 x 65.5 x 48.3	2

Previous Generation

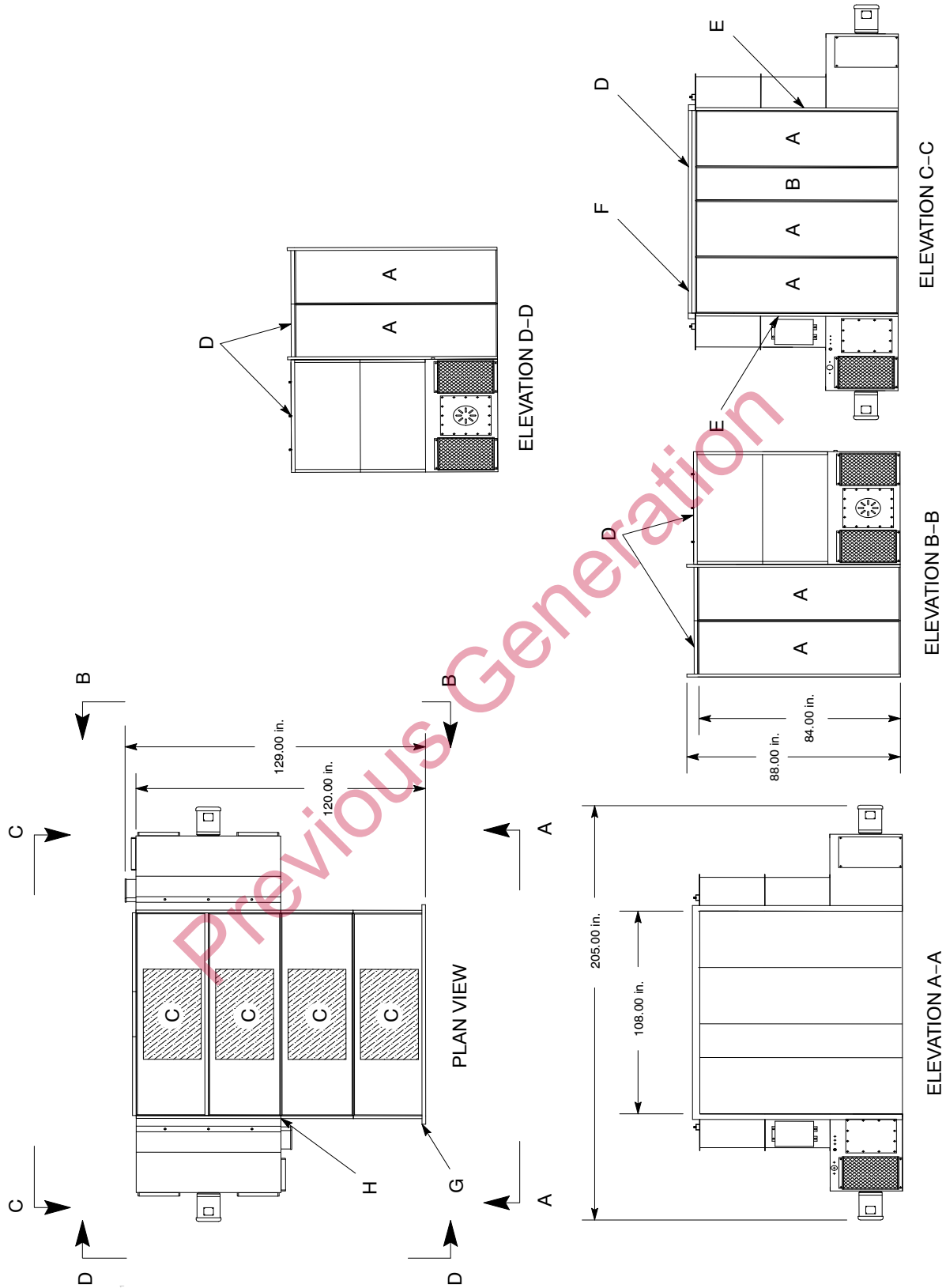

Figure 4-6 Model 3402 Assembly Drawing

Model 3403

Refer to Table 4-6 and Figure 4-7.

Table 4-6 Model 3403

Item	Description	Dimensions, in.	Quantity
A	Wall panel	96 x 30	7
B	Wall panel	96 x 6	1
C	Wall panel	60 x 12	2
D	Roof panel	96 x 30	4
E	Bracket	48	6
F	Bracket	60	4
—	Collector module	84.1 x 65.5 x 48.3	2

Previous Generation

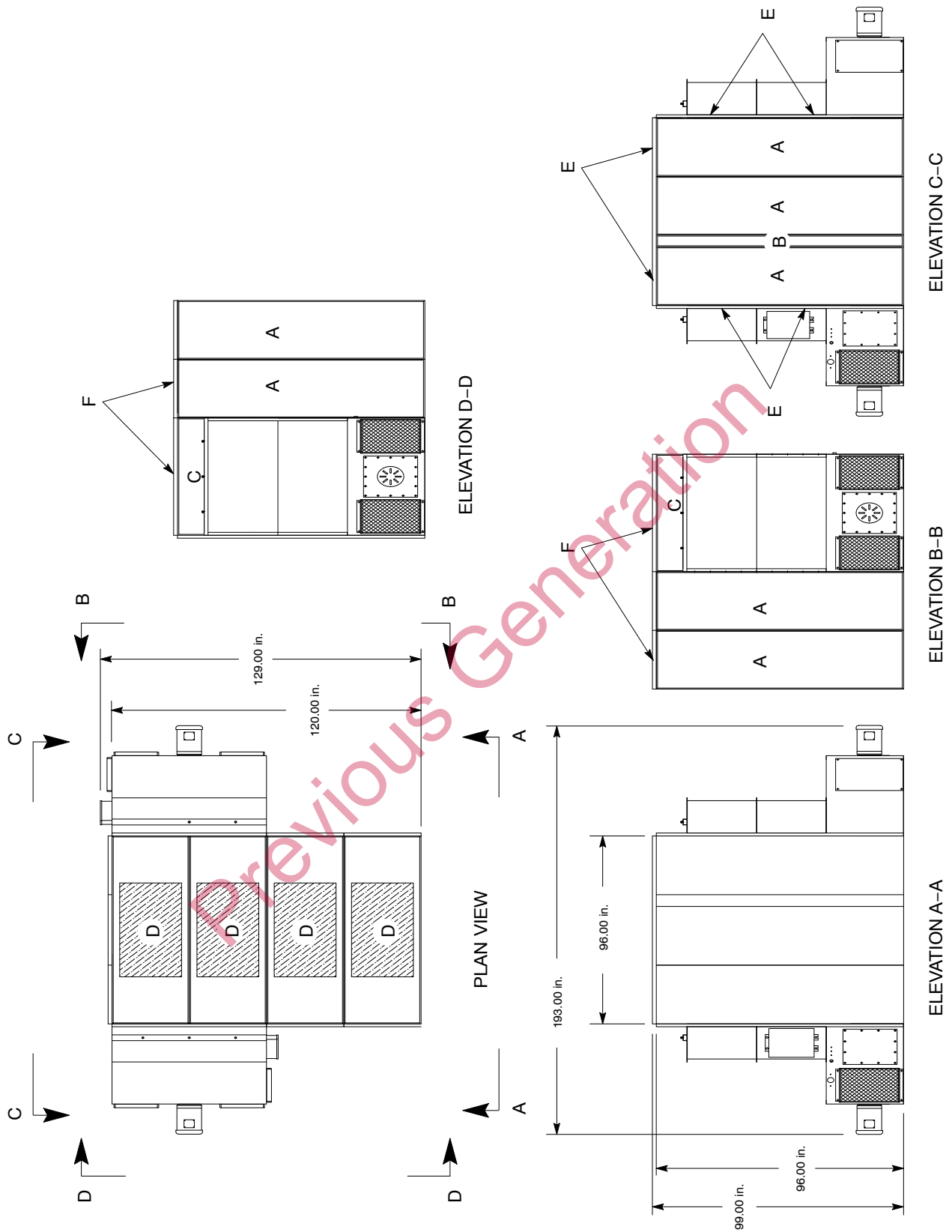

Figure 4-7 Model 3403 Assembly Drawing

5300-cfm Batch Booths

Use the following bills of materials and assembly drawings to assemble a 5300-cfm batch booth.

Model 5301

Refer to Table 4-7 and Figure 4-8.

Table 4-7 Model 5301

Item	Description	Dimensions, in.	Quantity
A	Wall panel	96 x 30	8
B	Wall panel	96 x 12	2
C	Roof panel	84 x 30	4
D	Bracket	60	4
E	Bracket	48	4
F	Bracket	84	1
—	Collector module	96.1 x 65.5 x 54.0	1

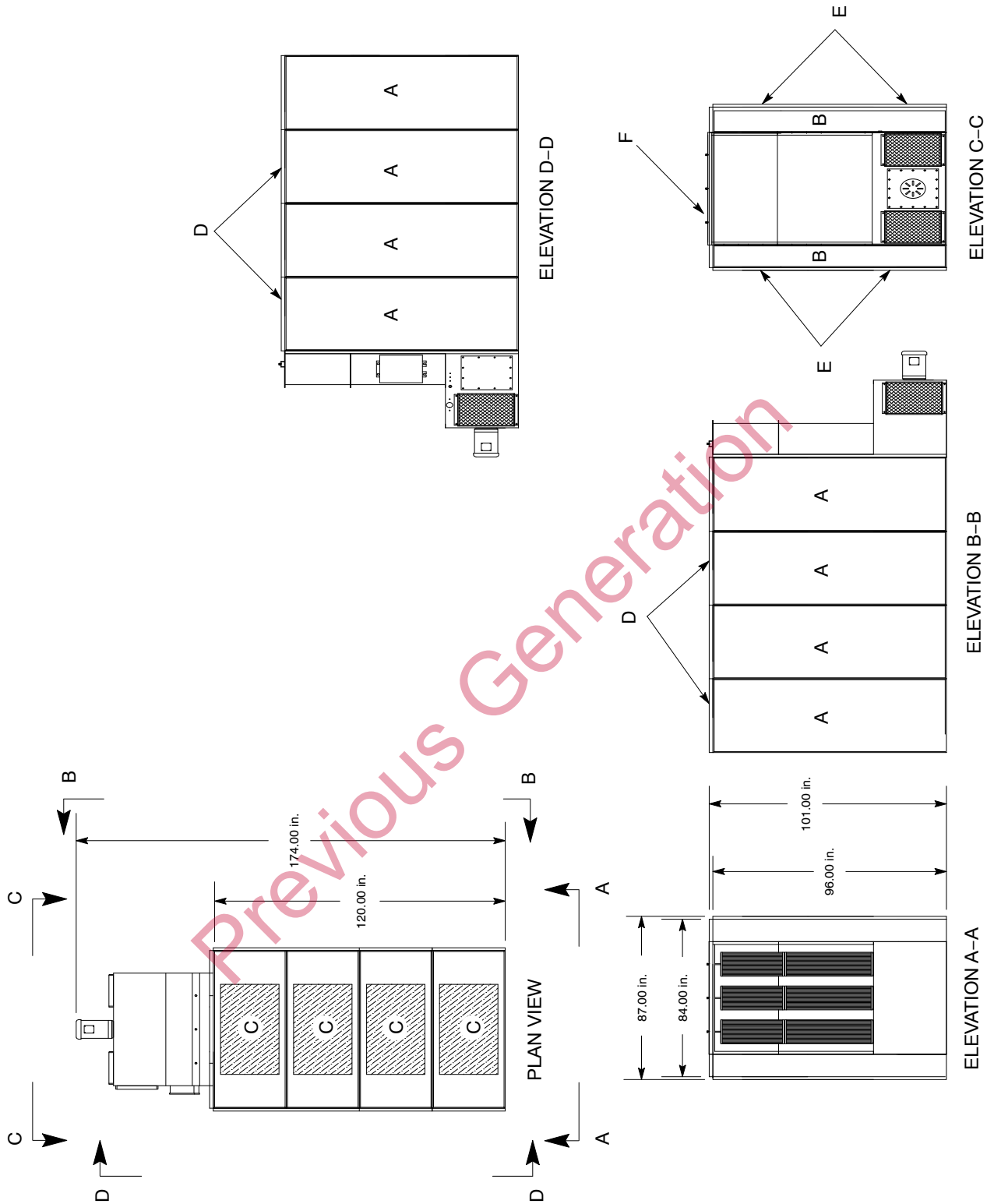

Figure 4-8 Model 5301 Assembly Drawing

Model 5302

Refer to Table 4-8 and Figure 4-9.

Table 4-8 Model 5302

Item	Description	Dimensions, in.	Quantity
A	Wall panel	96 x 30	8
B	Roof panel	120 x 30	4
C	Bracket	30	8
D	Bracket	48	4
E	Bracket	60	2
F	Roof support	96 x 120	2
G	Horizontal roof support	120	2
—	Collector module	96.1 x 65.5 x 54.0	1

Previous Generation

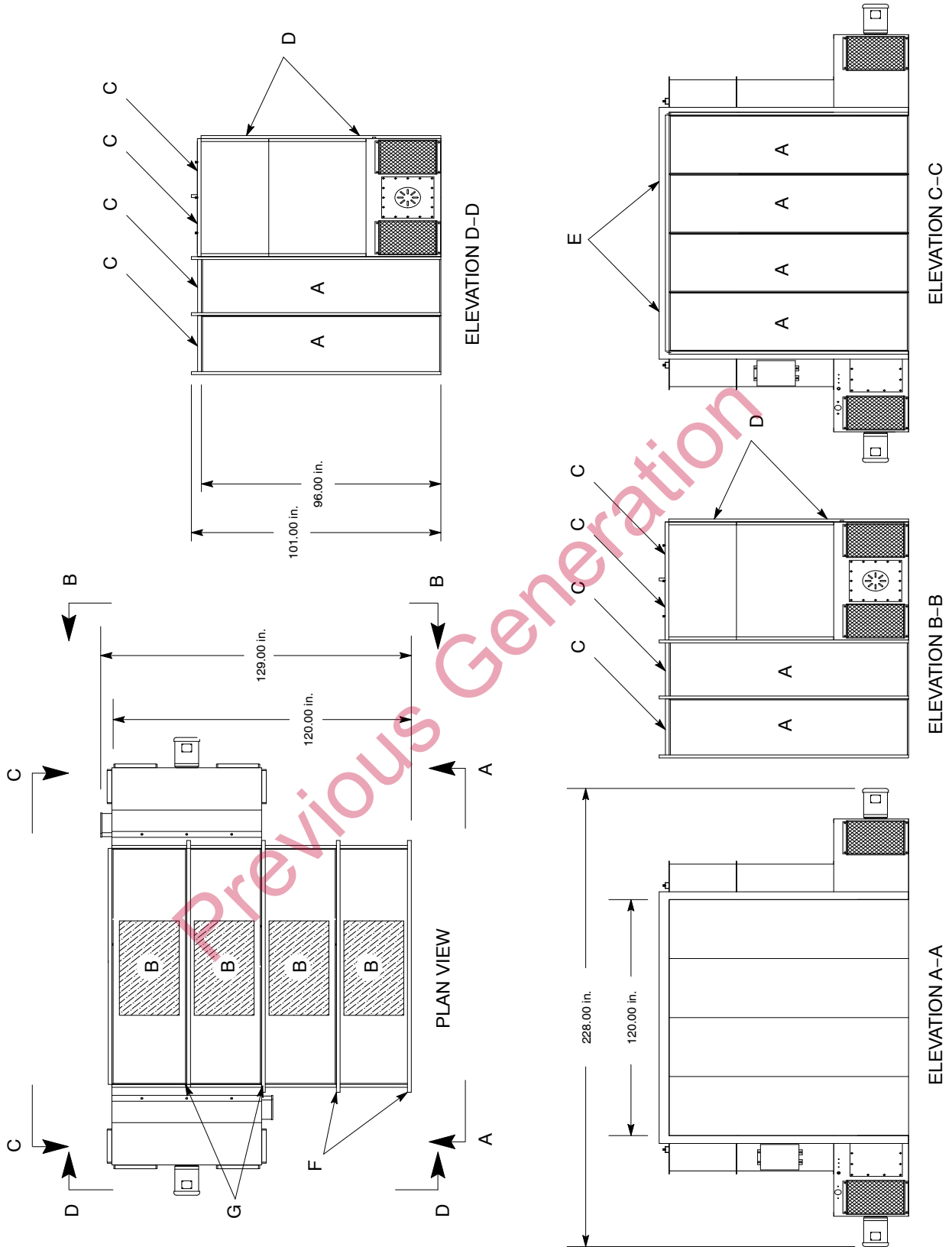

Figure 4-9 Model 5302 Assembly Drawing

Model 5303

Refer to Table 4-9 and Figure 4-10.

Table 4-9 Model 5303

Item	Description	Dimensions, in.	Quantity
A	Wall panel	96 x 30	8
B	Wall panel	96 x 24	1
C	Roof panel	84 x 30	4
D	Roof panel	60 x 30	4
E	Bracket	30	8
F	Bracket	48	4
G	Bracket	72	2
H	Roof support	96 x 144	2
I	Horizontal roof support	144	2
—	Collector module	96.1 x 65.5 x 54.0	2

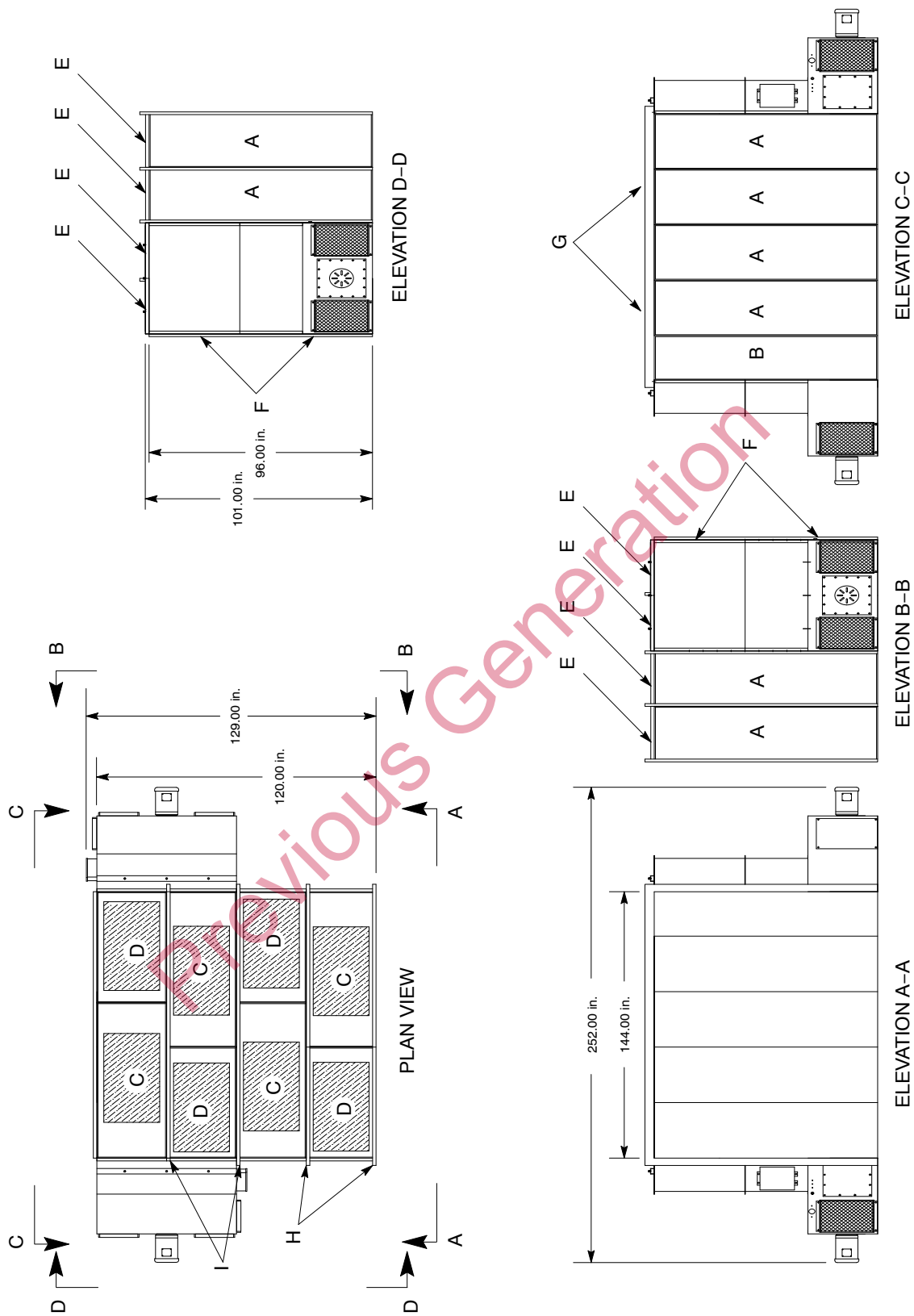

Figure 4-10 Model 5303 Assembly Drawing

Model 5304

Refer to Table 4-10 and Figure 4-11.

Table 4-10 Model 5304

Item	Description	Dimensions, in.	Quantity
A	Wall panel	96 x 30	8
B	Wall panel	96 x 24	2
C	Roof panel	96 x 30	4
D	Roof panel	72 x 30	4
E	Bracket	30	8
F	Bracket	48	4
G	Bracket	84	2
H	Roof support	96 x 168	4
—	Collector module	96.1 x 65.5 x 54.0	2

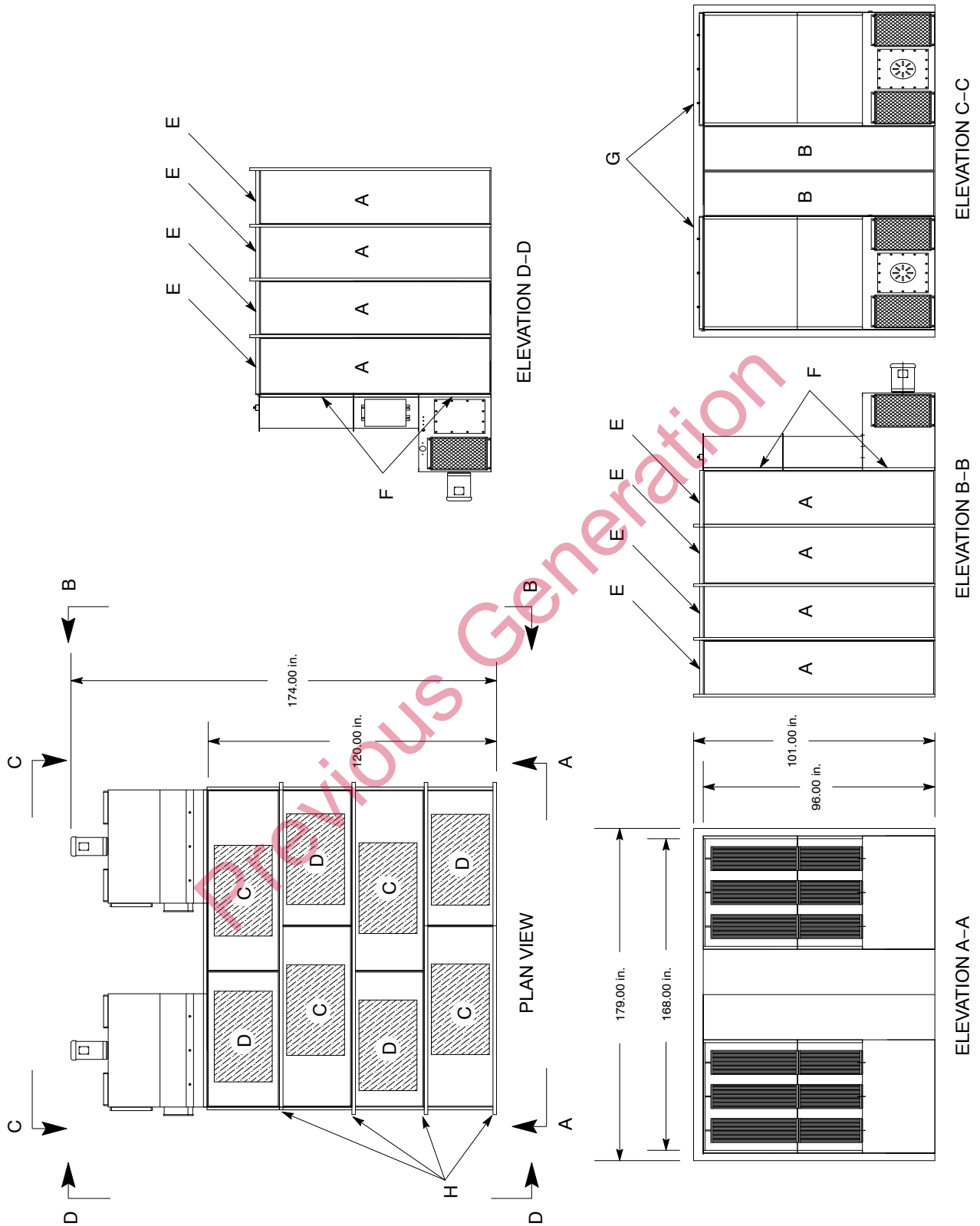

Figure 4-11 Model 5304 Assembly Drawing

Model 5305

Refer to Table 4-11 and Figure 4-12.

Table 4-11 Model 5305

Item	Description	Dimensions, in.	Quantity
A	Wall panel	108 x 30	8
B	Wall panel	108 x 24	1
C	Roof panel	84 x 30	4
D	Roof panel	60 x 30	4
E	Bracket	30	8
F	Bracket	48	2
G	Bracket	60	2
H	Bracket	72	2
I	Roof support	108 x 144	2
J	Wall panel	60 x 12	2
K	Horizontal roof support	144	2
—	Collector module	96.1 x 65.5 x 54.0	2

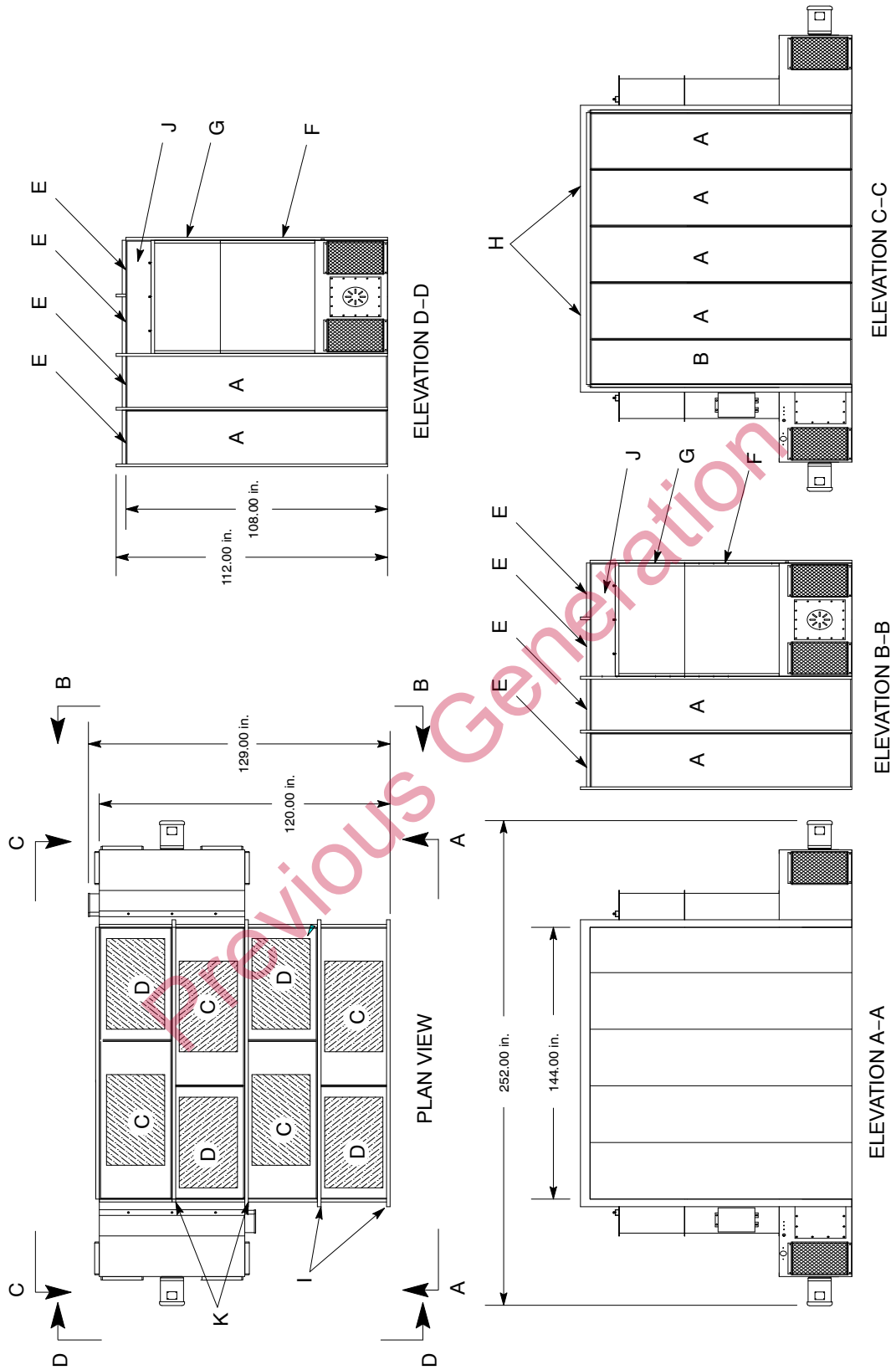

Figure 4-12 Model 5305 Assembly Drawing

Model 5306

Refer to Table 4-12 and Figure 4-13.

Table 4-12 Model 5306

Item	Description	Dimensions, in.	Quantity
A	Wall panel	120 x 30	8
B	Wall panel	60 x 24	2
C	Roof panel	120 x 30	4
D	Bracket	30	8
E	Bracket	60	6
F	Roof support	120 x 120	2
G	Horizontal roof support	120	2
—	Collector module	96.1 x 65.5 x 54.0	2

Previous Generation

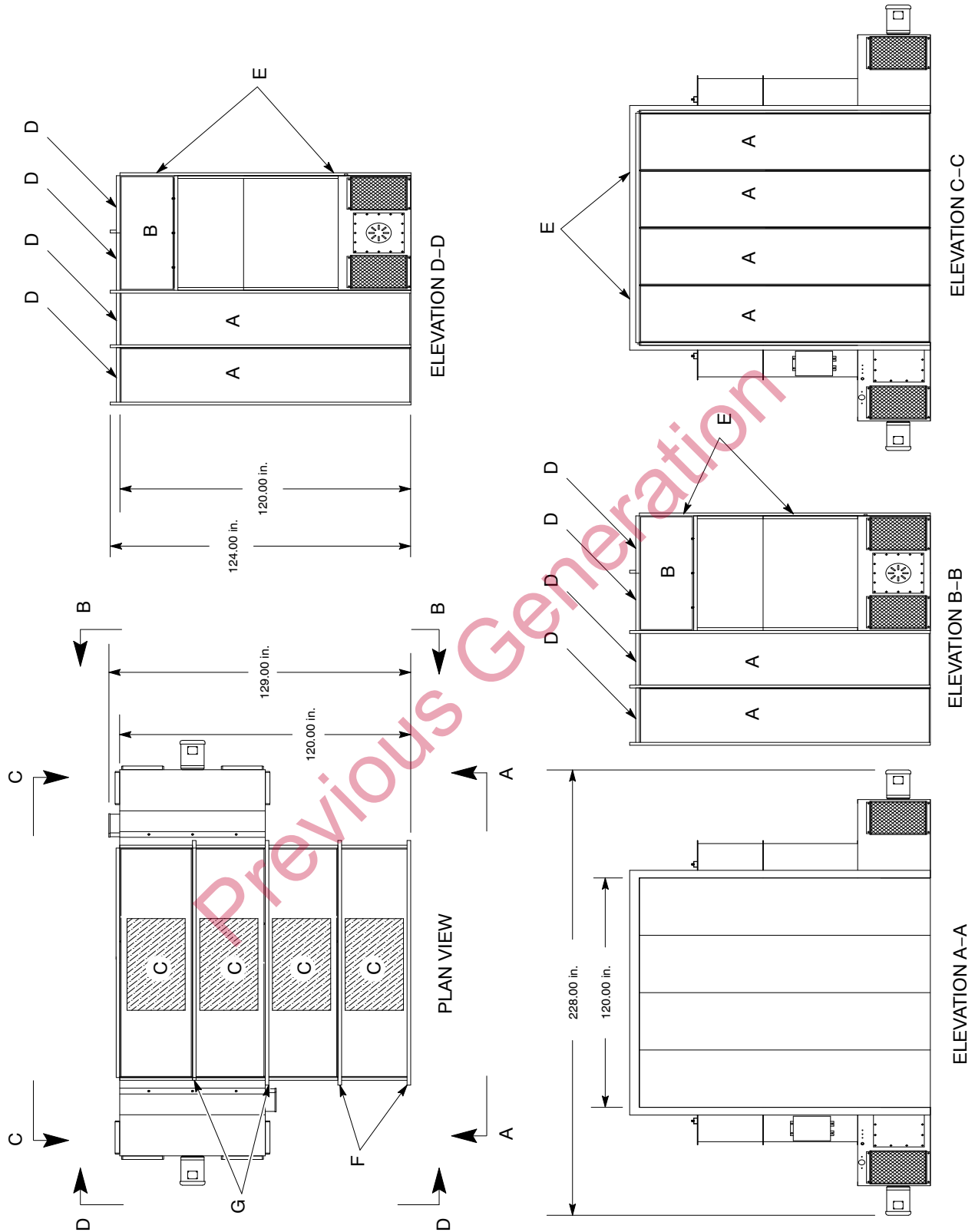

Figure 4-13 Model 5306 Assembly Drawing

Model 5307

Refer to Table 4-13 and Figure 4-14.

Table 4-13 Model 5307

Item	Description	Dimensions, in.	Quantity
A	Wall panel	84 x 30	6
B	Wall panel	60 x 30	6
C	Wall panel	60 x 18	2
D	Wall panel	84 x 18	2
E	Wall panel	60 x 24	4
F	Roof panel	96 x 30	4
G	Bracket	48	2
H	Bracket	72	4
I	Bracket	60	4
—	Collector module	96.1 x 65.5 x 54.0	2

Previous Generation

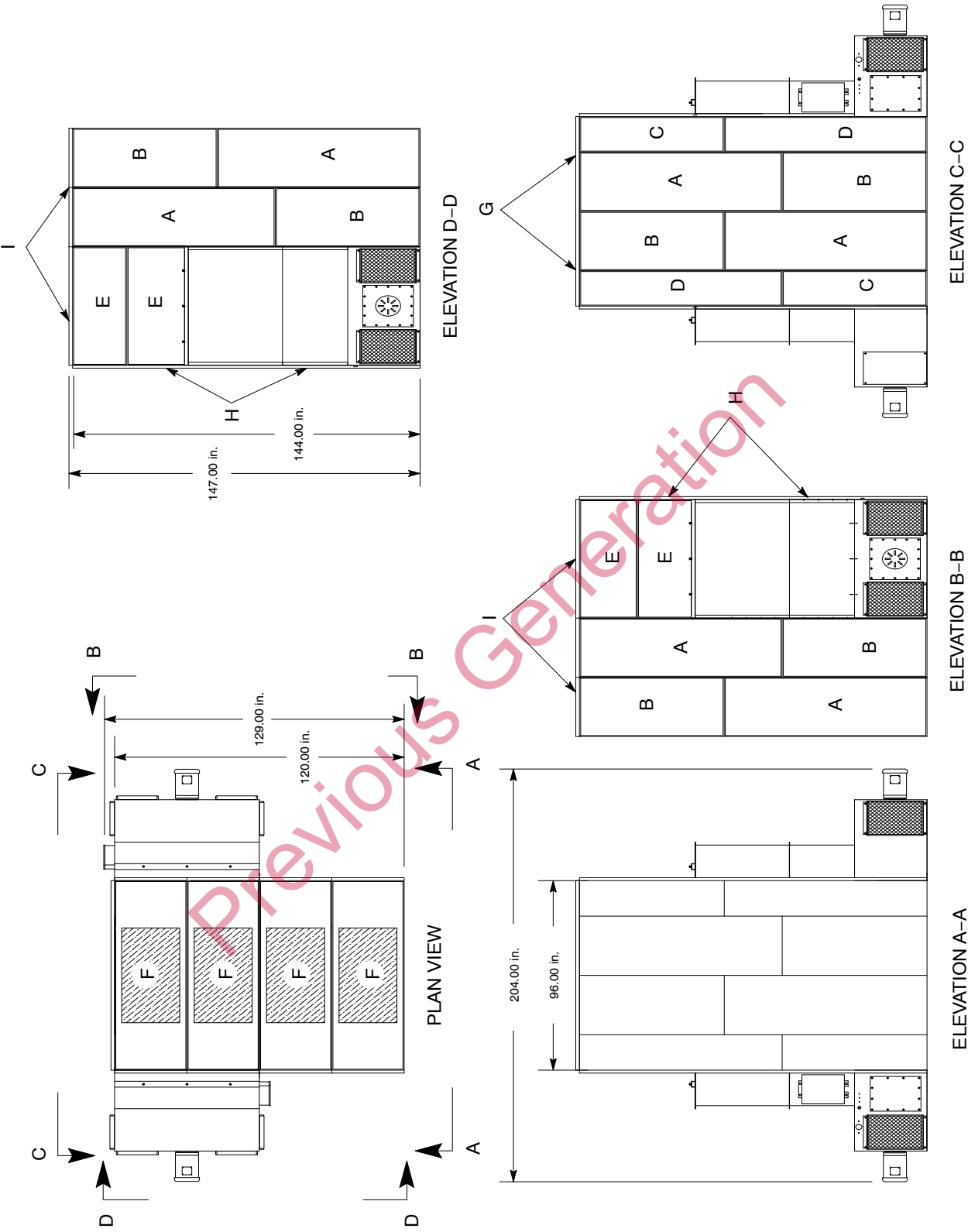

Figure 4-14 Model 5307 Assembly Drawing

6000-cfm Batch Booths

Use the following bills of materials and assembly drawings to assemble a 6000-cfm batch booth.

Model 6001

Refer to Table 4-14 and Figure 4-15.

Table 4-14 Model 6001

Item	Description	Dimensions, in.	Quantity
A	Wall panel	108 x 30	8
B	Wall panel	108 x 12	2
C	Roof panel	84 x 30	4
D	Bracket	60	6
E	Bracket	48	2
F	Bracket	84	1
—	Collector module	108.1 x 65.5 x 54.0	1

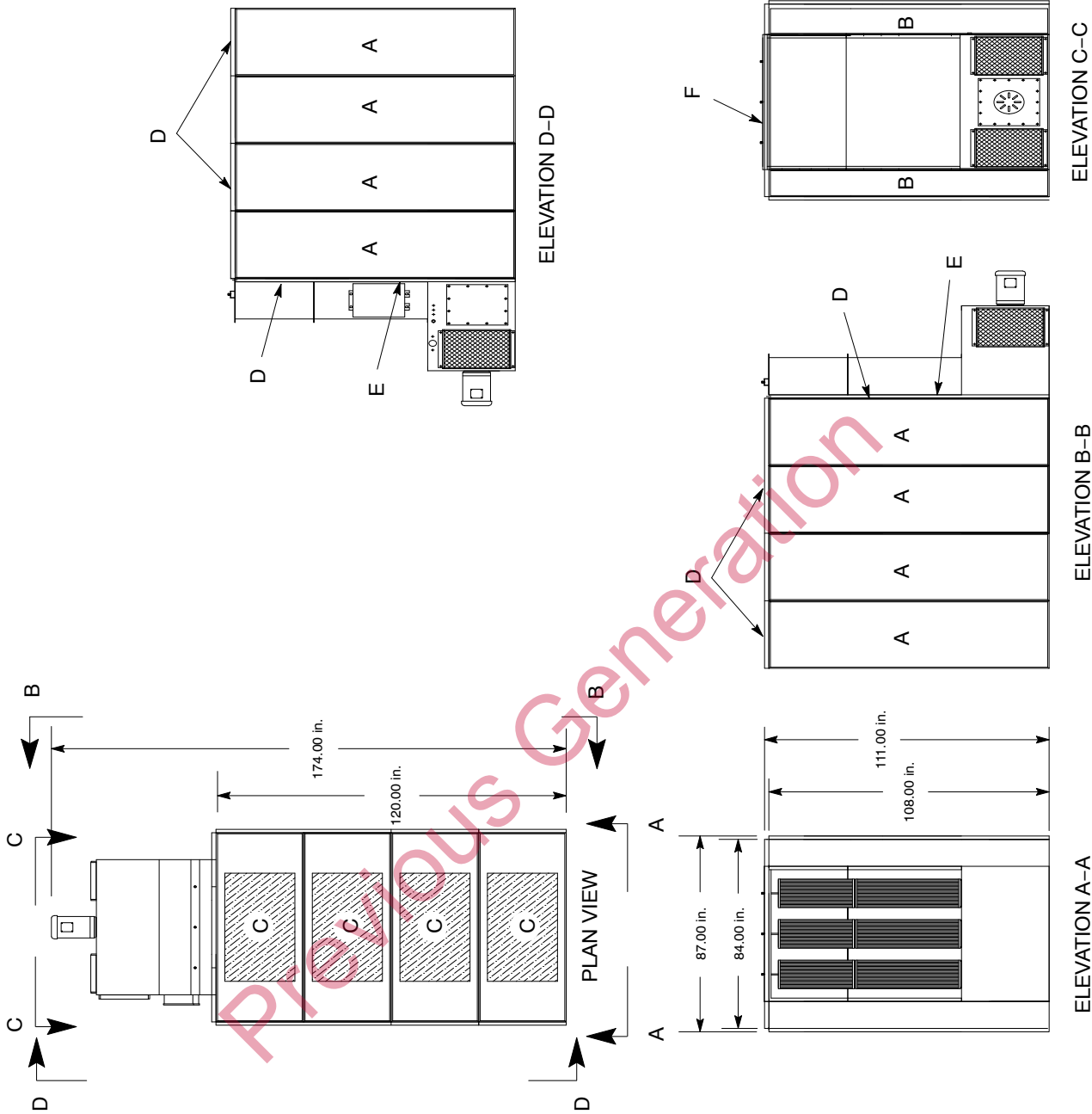

Figure 4-15 Model 6001 Assembly Drawing

Model 6002

Refer to Table 4-15 and Figure 4-16.

Table 4-15 Model 6002

Item	Description	Dimensions, in.	Quantity
A	Wall panel	108 x 30	8
B	Wall panel	108 x 24	2
C	Roof panel	96 x 30	4
D	Roof panel	72 x 30	4
E	Bracket	30	8
F	Bracket	48	2
G	Bracket	60	2
H	Bracket	84	2
I	Roof support	108 x 168	2
J	Horizontal roof support	168	2
—	Collector module	108.1 x 65.5 x 54.0	2

Previous Generation

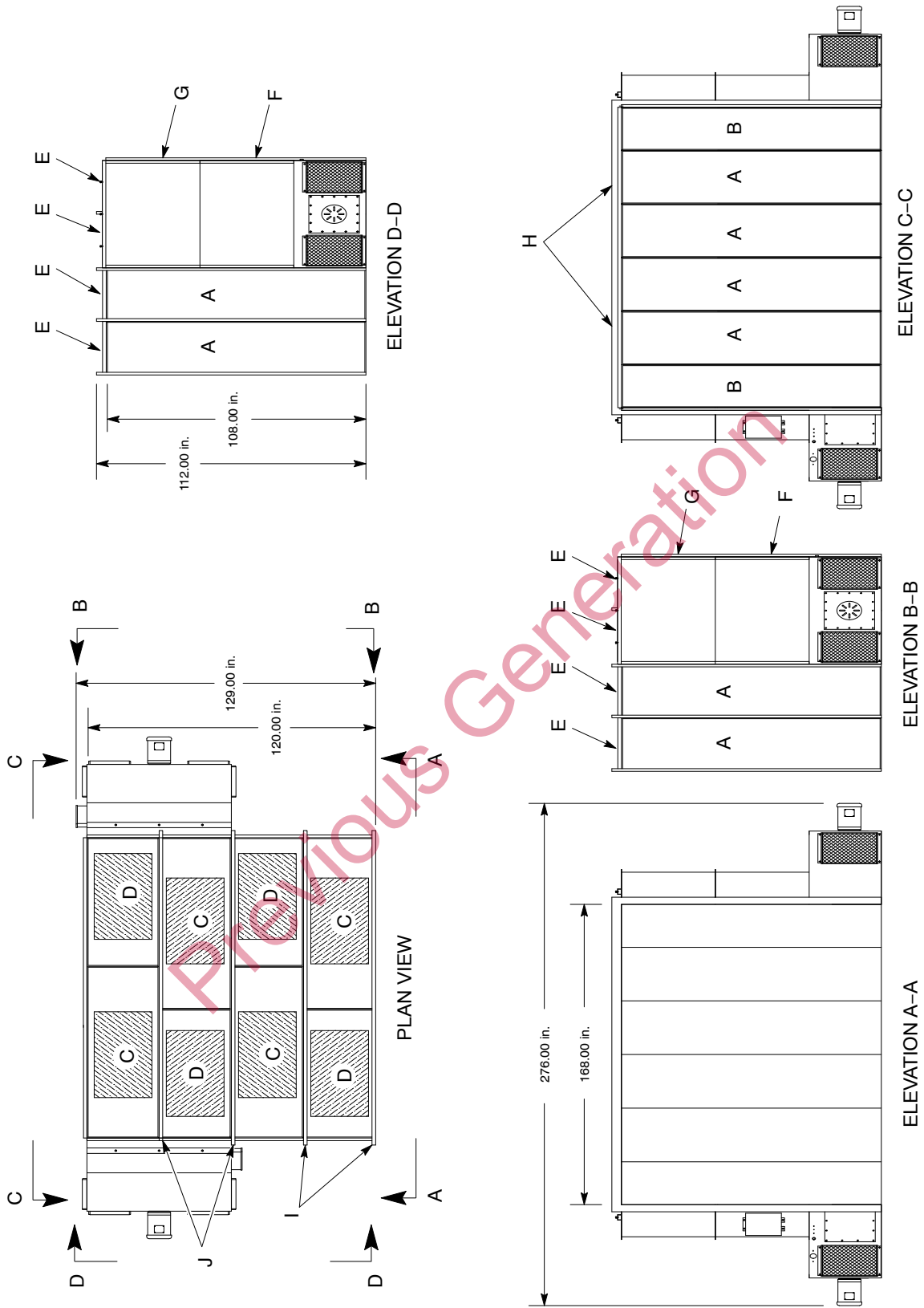

Figure 4-16 Model 6002 Assembly Drawing

Model 6003

Refer to Table 4-16 and Figure 4-17.

Table 4-16 Model 6003

Item	Description	Dimensions, in.	Quantity
A	Wall panel	120 x 30	8
B	Wall panel	120 x 6	2
C	Wall panel	60 x 12	1
D	Roof panel	72 x 30	4
E	Bracket	60	8
F	Bracket	72	1
—	Collector module	108.1 x 65.5 x 54.0	1

Previous Generation

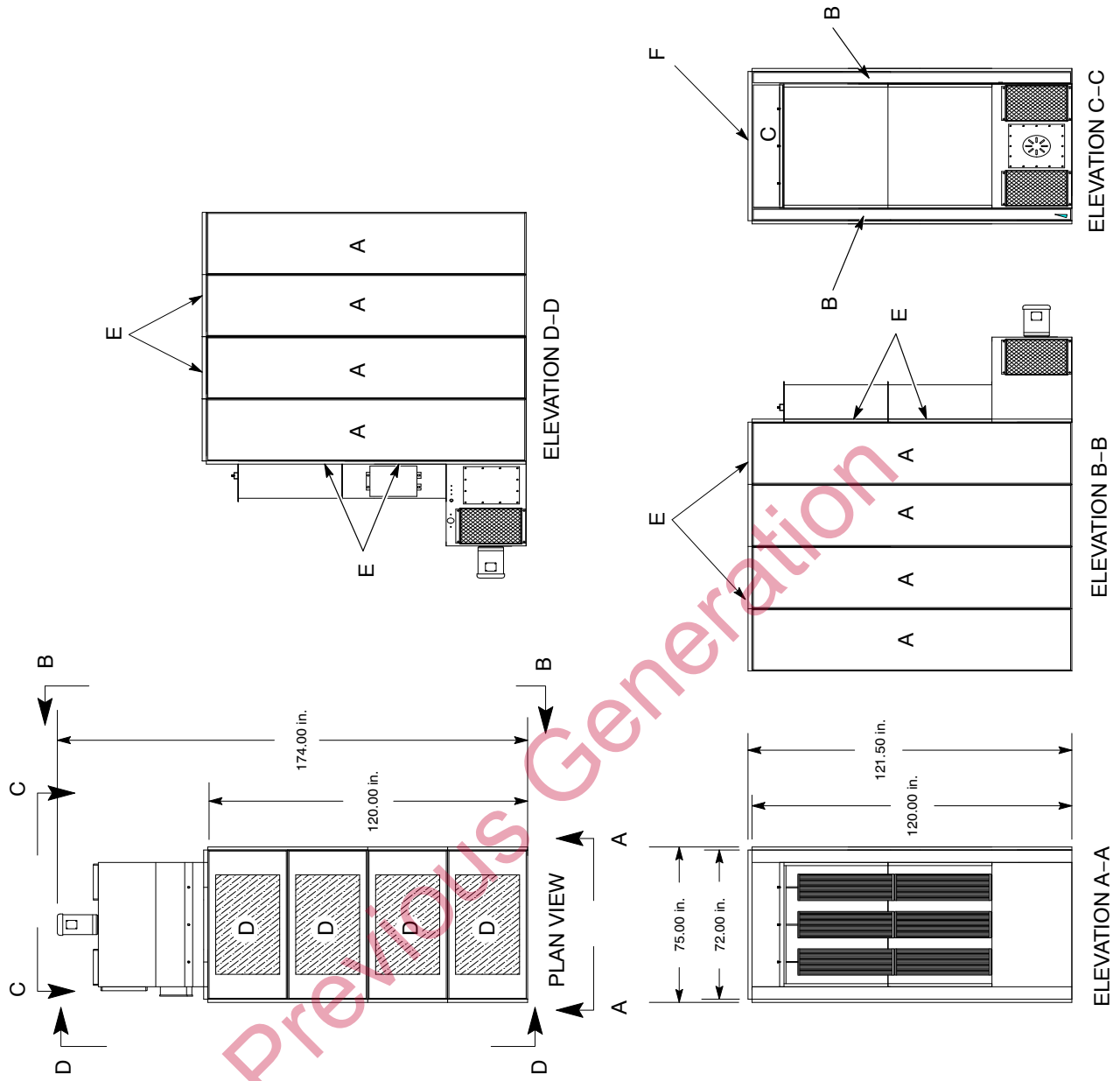

Figure 4-17 Model 6003 Assembly Drawing

Model 6004

Refer to Table 4-17 and Figure 4-18.

Table 4-17 Model 6004

Item	Description	Dimensions, in.	Quantity
A	Wall panel	120 x 30	8
B	Wall panel	120 x 12	2
C	Wall panel	60 x 12	2
D	Roof panel	84 x 30	4
E	Roof panel	60 x 30	4
F	Bracket	60	4
G	Bracket	72	2
H	Bracket	30	8
I	Roof support	120 x 144	2
J	Horizontal roof support	144	2
—	Collector module	108.1 x 65.5 x 54.0	2

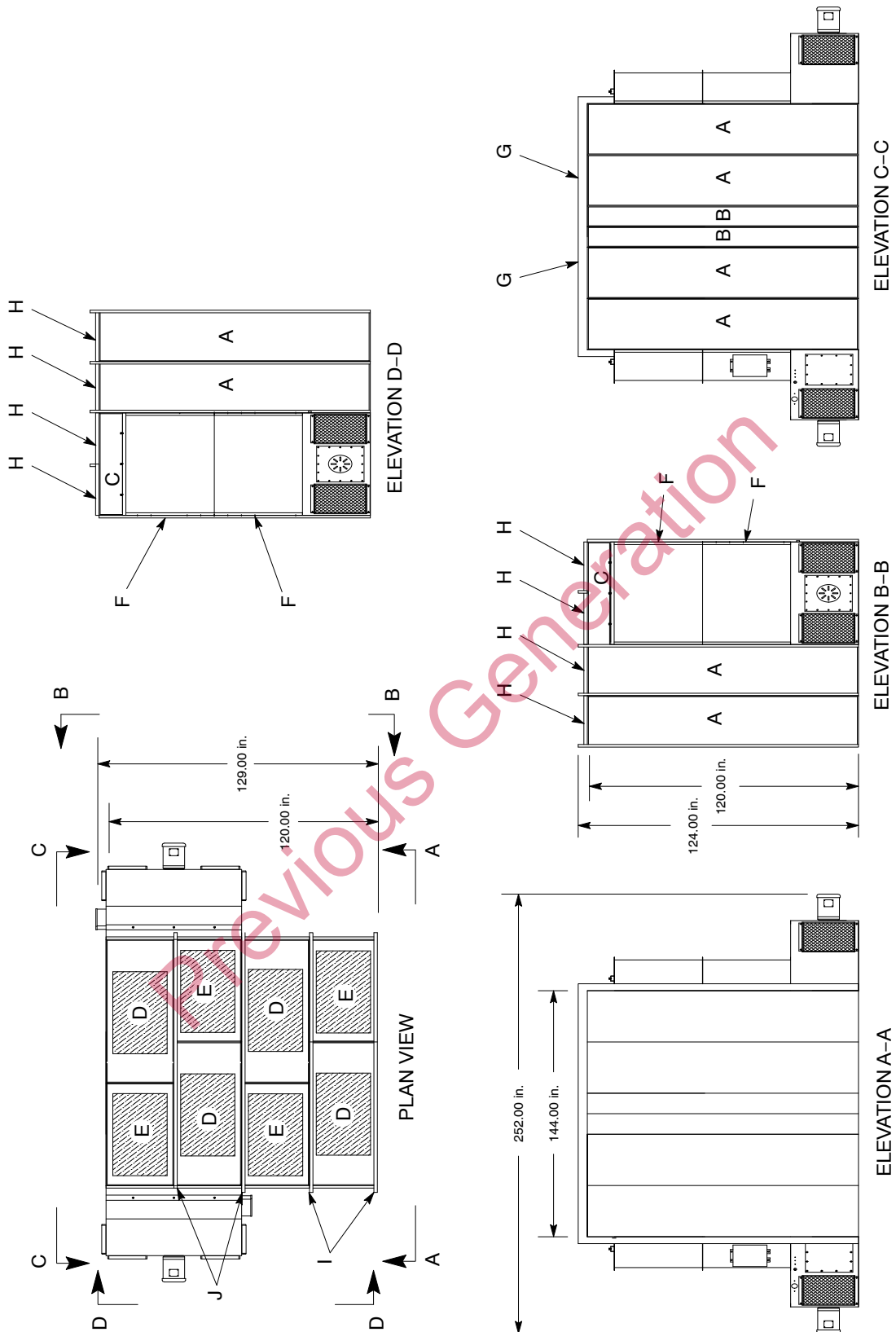

Figure 4-18 Model 6004 Assembly Drawing

5300-cfm Conveyor Booths

Use the following bills of materials and assembly drawings to assemble a 5300-cfm conveyor booth.

Model 5300C1

Refer to Table 4-18 and Figure 4-19.

Table 4-18 Model 5300C1

Item	Description	Dimensions, in.	Quantity
A	Wall panel	12 x 60	6
B	Wall panel	12 x 27	4
C	Wall panel	24 x 30	4
D	Wall panel	15 x 72	2
E	Roof panel	28.5 x 63	2
F	Bracket	72	2
G	Bracket	96	2
H	Hinge	24	2
—	Collector module	96.1 x 65.5 x 54.0	1

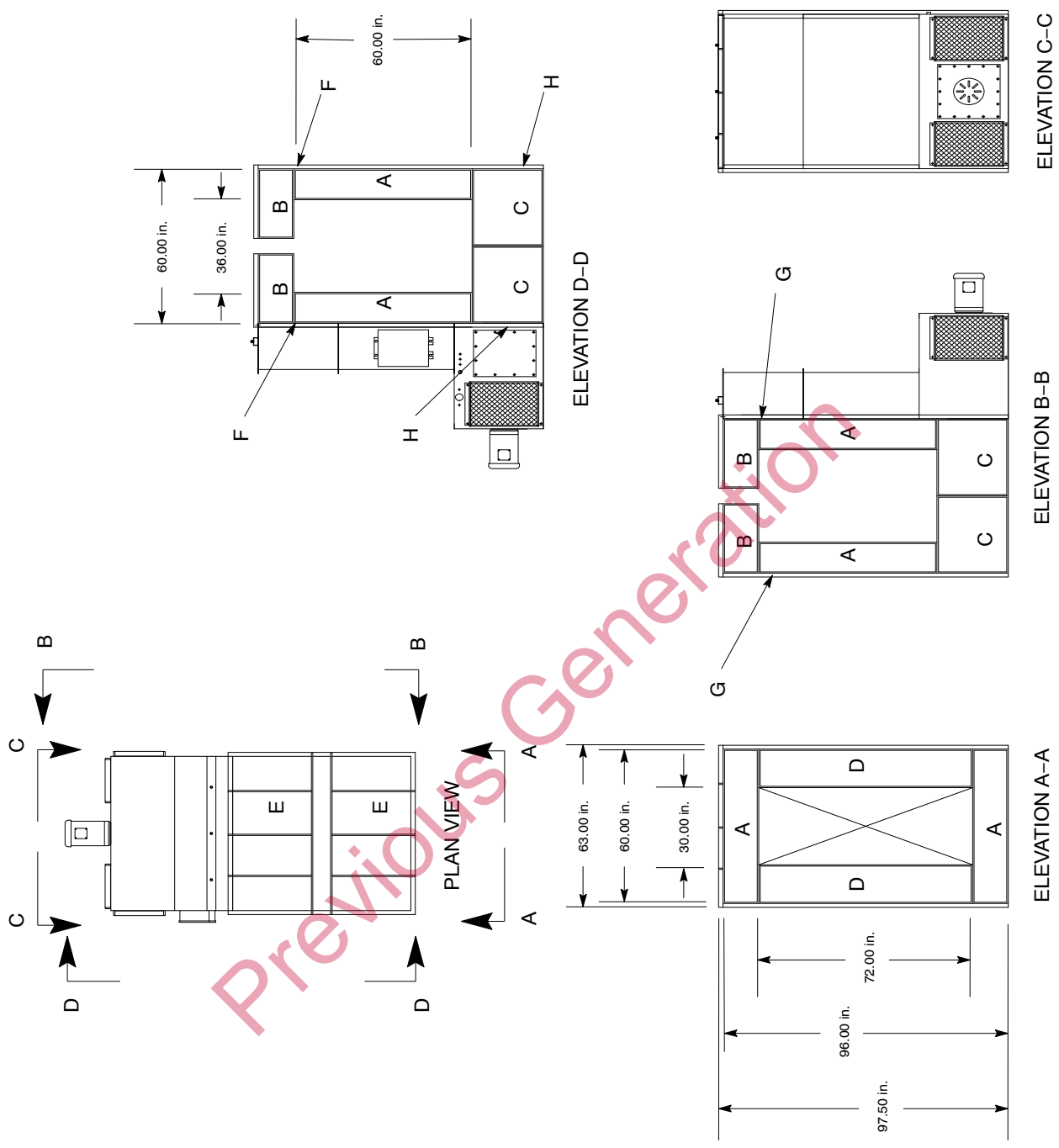

Figure 4-19 Model 5300C1 Assembly Drawing

Model 5300C2

Refer to Table 4-19 and Figure 4-20.

Table 4-19 Model 5300C2

Item	Description	Dimensions, in.	Quantity
A	Wall panel	12 x 60	5
B	Wall panel	12 x 27	4
C	Wall panel	30 x 30	4
D	Wall panel	15 x 72	2
E	Wall panel	18 x 60	1
F	Wall panel	6 x 60	1
G	Roof panel	28.5 x 63	2
H	Bracket	72	2
I	Bracket	102	2
J	Hinge	30	2
—	Collector module	96.1 x 65.5 x 54.0	1

Previous Generation

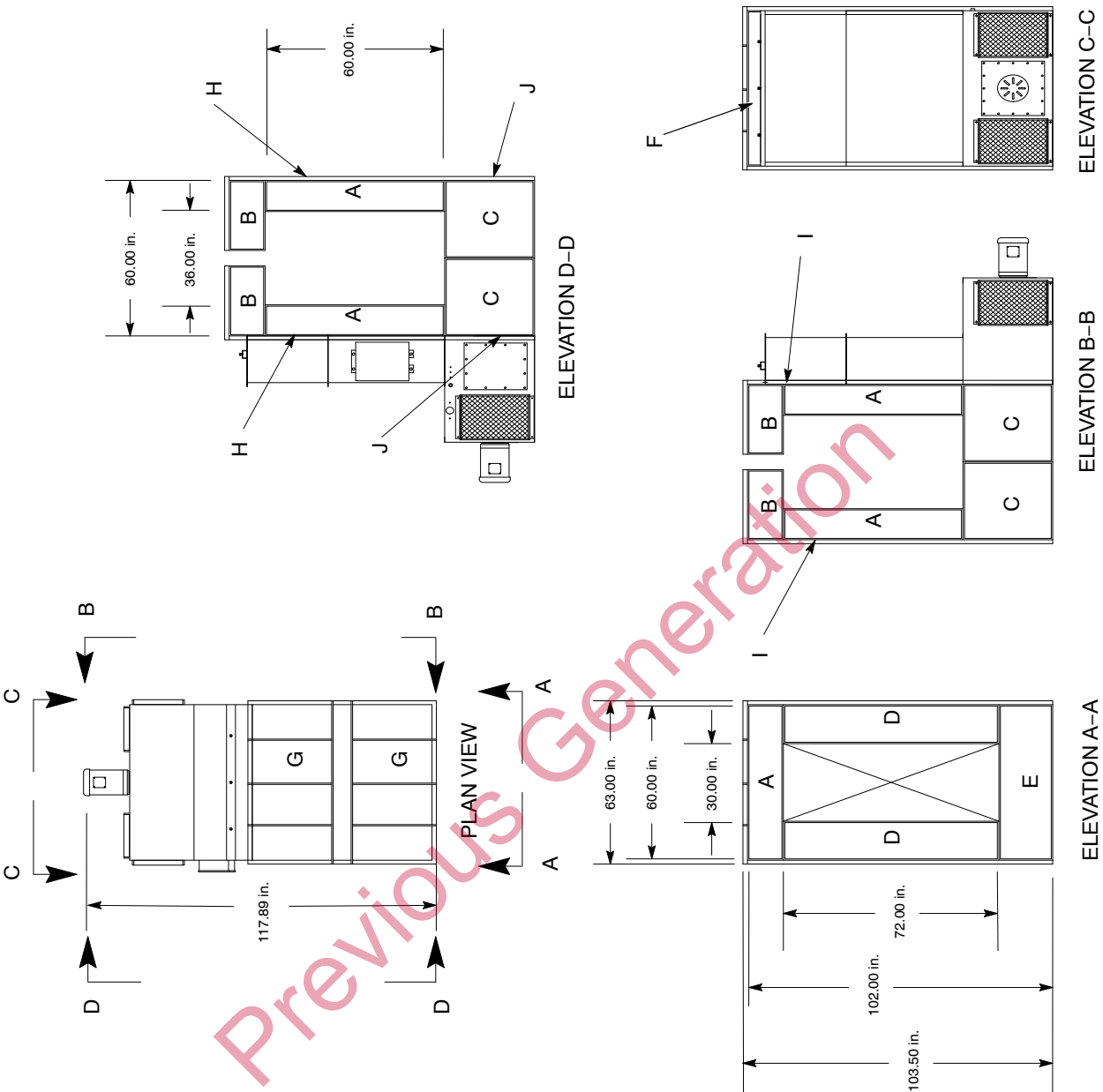

Figure 4-20 Model 5300C2 Assembly Drawing

Model 5300C3

Refer to Table 4-20 and Figure 4-21.

Table 4-20 Model 5300C3

Item	Description	Dimensions, in.	Quantity
A	Wall panel	12 x 60	6
B	Wall panel	12 x 27	4
C	Wall panel	30 x 36	4
D	Wall panel	15 x 72	2
E	Wall panel	24 x 60	1
F	Roof panel	28.5 x 63	2
G	Bracket	72	2
H	Hinge	36	2
I	Bracket	108	2
—	Collector module	96.1 x 65.5 x 54.0	1

Previous Generation

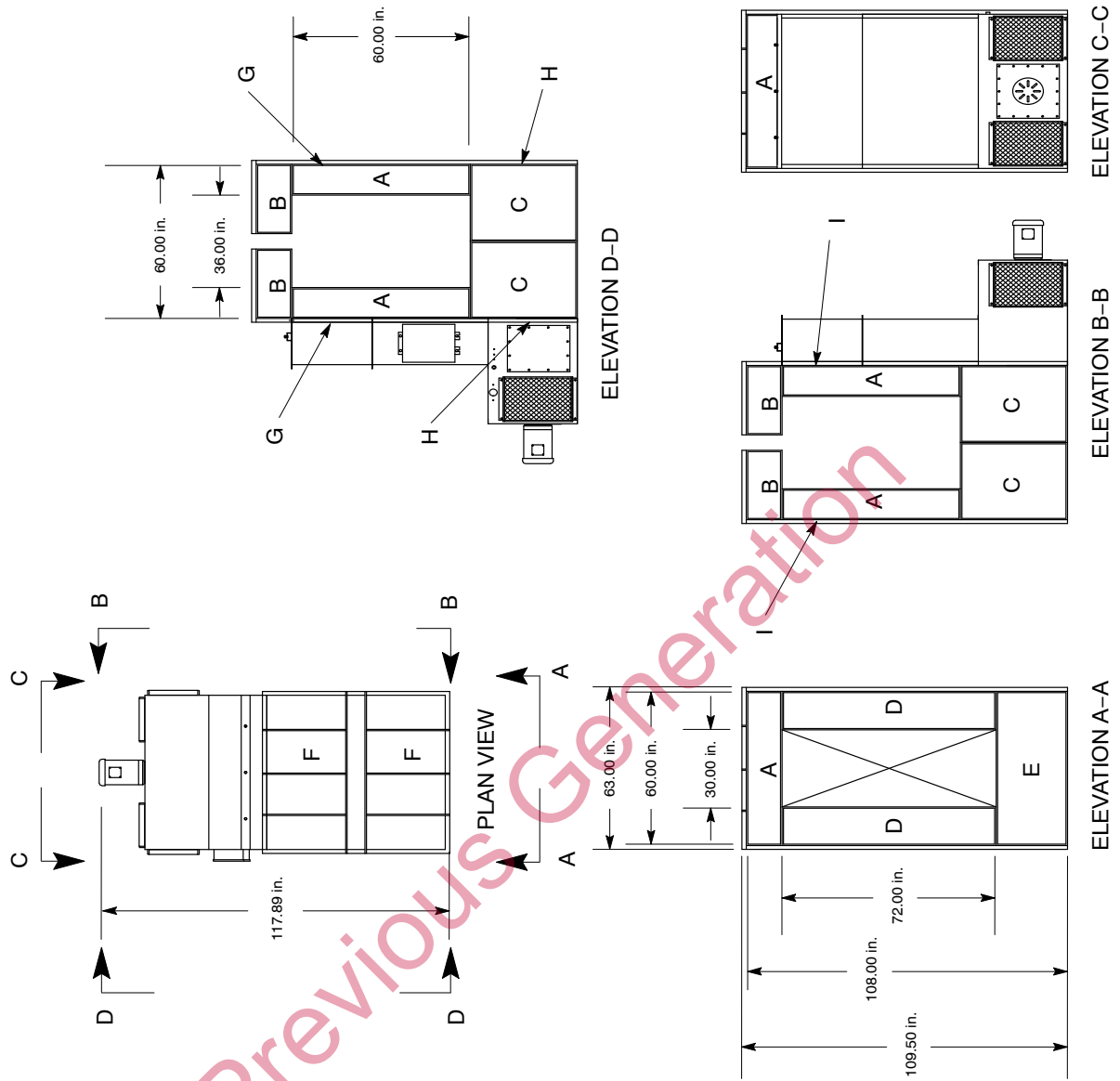

Figure 4-21 Model 5300C3 Assembly Drawing

Model 5300C4

Refer to Table 4-21 and Figure 4-22.

Table 4-21 Model 5300C4

Item	Description	Dimensions, in.	Quantity
A	Wall panel	12 x 60	5
B	Wall panel	12 x 27	4
C	Wall panel	30 x 42	4
D	Wall panel	15 x 72	2
E	Wall panel	30 x 60	1
F	Wall panel	18 x 60	1
G	Roof panel	28.5 x 63	2
H	Bracket	72	2
I	Hinge	42	2
J	Bracket	114	2
—	Collector module	96.1 x 65.5 x 54.0	1

Previous Generation

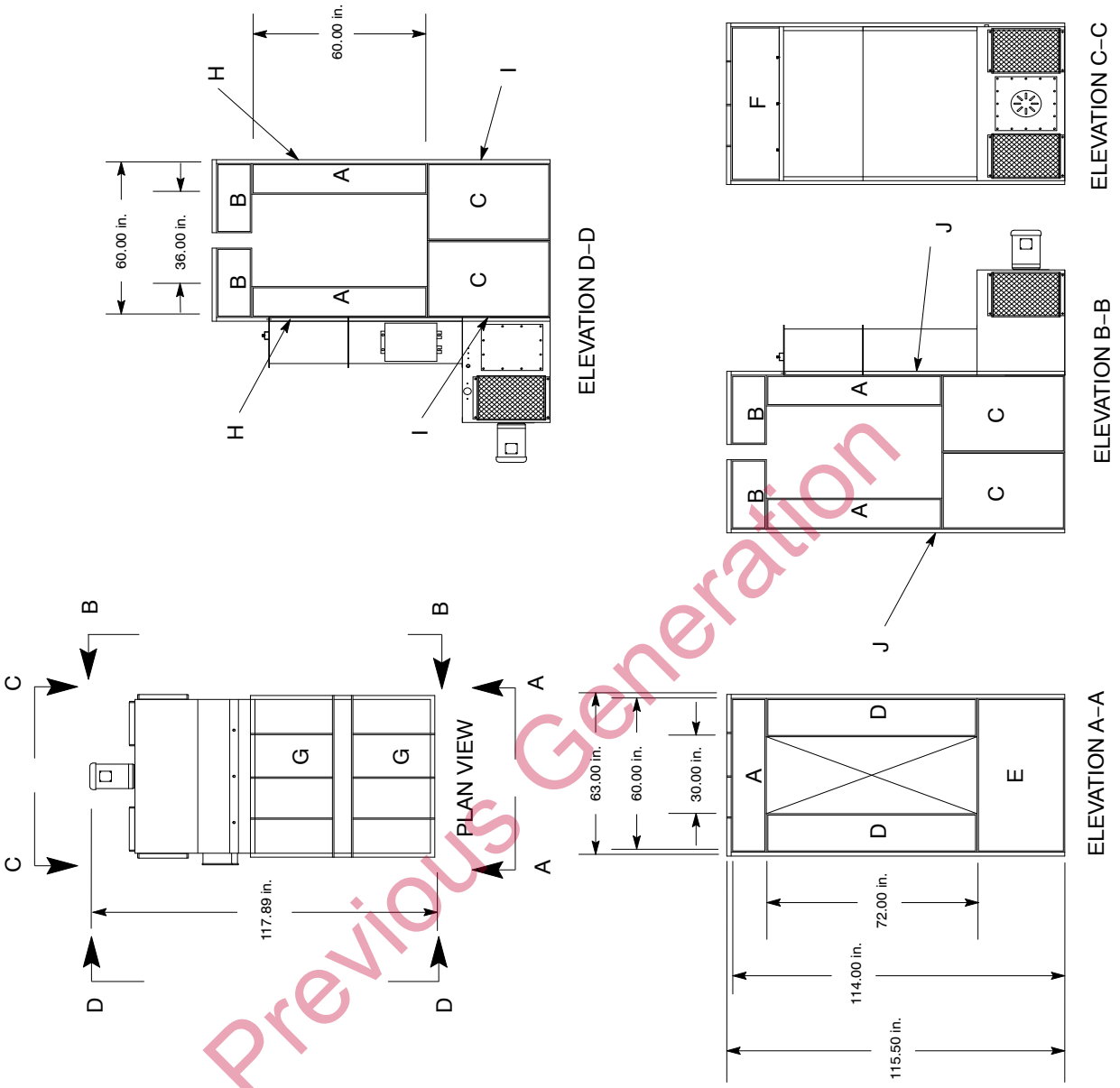

Figure 4-22 Model 5300C4 Assembly Drawing

Model 5300C5

Refer to Table 4-22 and Figure 4-23.

Table 4-22 Model 5300C5

Item	Description	Dimensions, in.	Quantity
A	Wall panel	12 x 60	5
B	Wall panel	12 x 27	4
C	Wall panel	30 x 48	4
D	Wall panel	15 x 72	2
E	Wall panel	36 x 60	1
F	Wall panel	24 x 60	1
G	Roof panel	28.5 x 63	2
H	Bracket	72	2
I	Hinge	48	2
J	Bracket	120	2
—	Collector module	96.1 x 65.5 x 54.0	1

Previous Generation

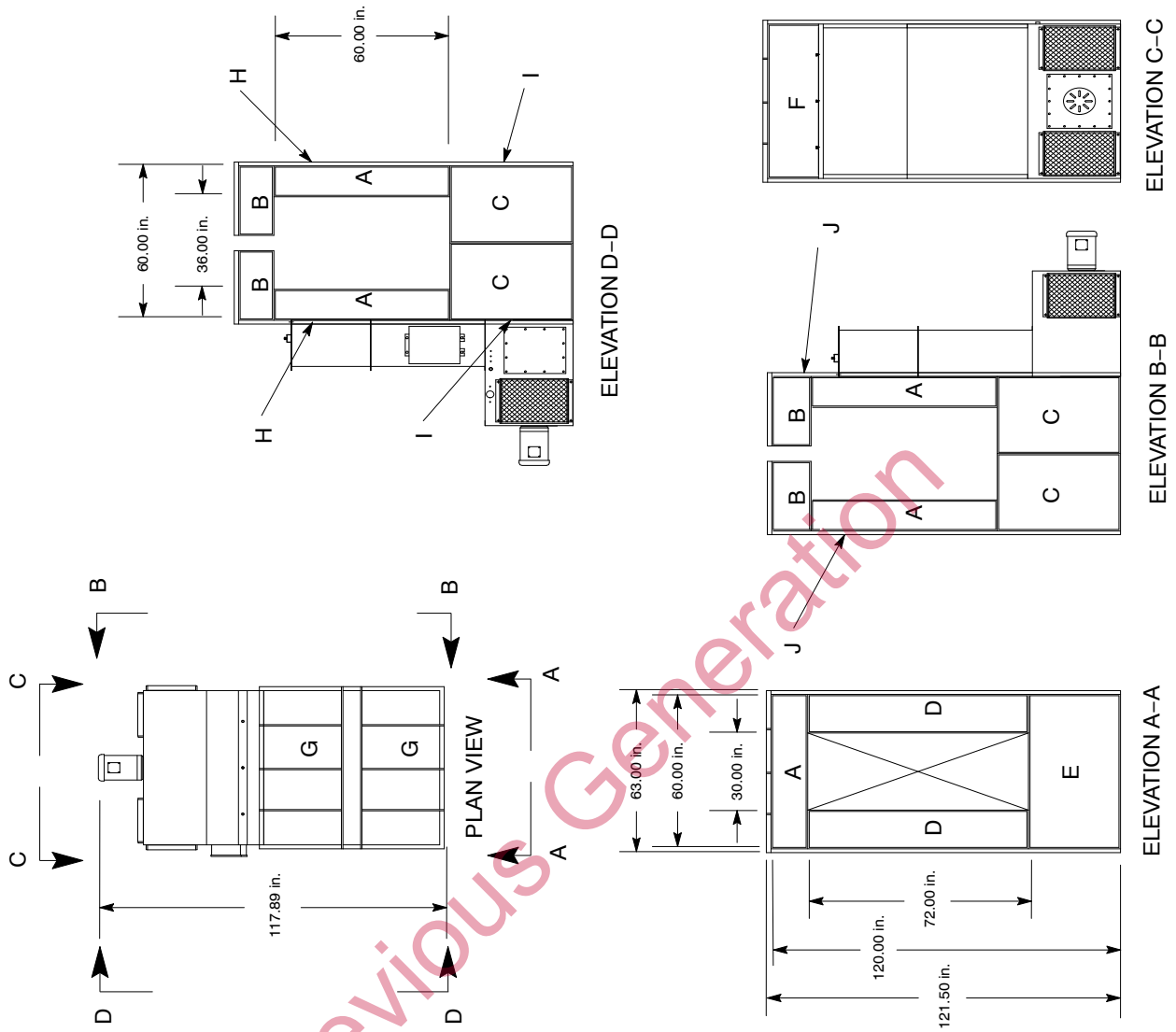

Figure 4-23 Model 5300C5 Assembly Drawing

Model 5300C6

Refer to Table 4-23 and Figure 4-24.

Table 4-23 Model 5300C6

Item	Description	Dimensions, in.	Quantity
A	Wall panel	12 x 60	5
B	Wall panel	12 x 27	4
C	Wall panel	30 x 54	4
D	Wall panel	15 x 72	2
E	Wall panel	42 x 60	1
F	Wall panel	30 x 60	1
G	Roof panel	28.5 x 63	2
H	Bracket	72	2
I	Hinge	54	2
J	Bracket	126	2
—	Collector module	96.1 x 65.5 x 54.0	1

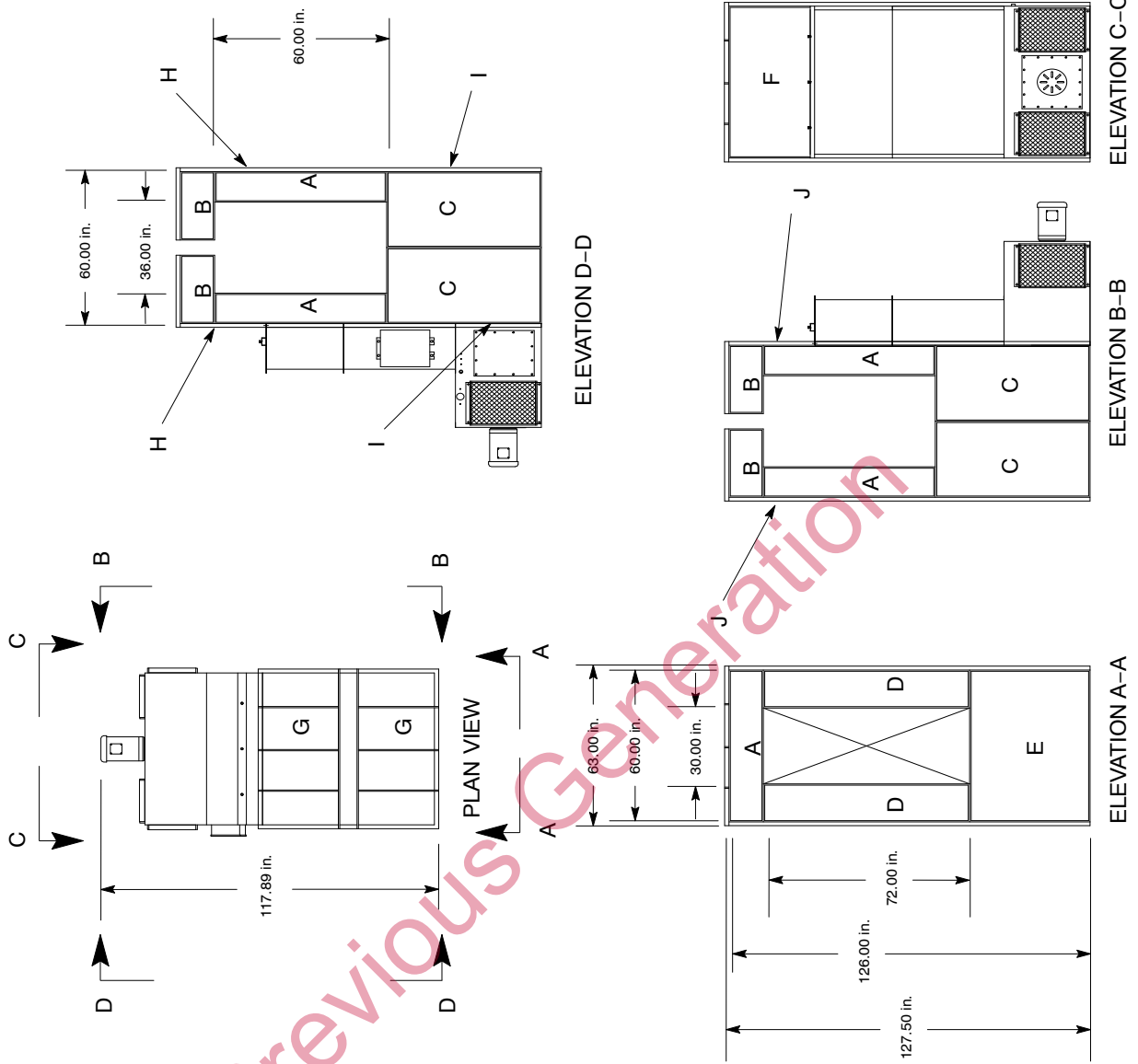

Figure 4-24 Model 5300C6 Assembly Drawing

Model 5300C7

Refer to Table 4-24 and Figure 4-25.

Table 4-24 Model 5300C7

Item	Description	Dimensions, in.	Quantity
A	Wall panel	12 x 60	5
B	Wall panel	12 x 27	4
C	Wall panel	30 x 60	4
D	Wall panel	15 x 72	2
E	Wall panel	30 x 48	2
F	Wall panel	36 x 60	1
G	Roof panel	28.5 x 63	2
H	Bracket	72	2
I	Hinge	60	2
J	Bracket	132	2
—	Collector module	96.1 x 65.5 x 54.0	1

Previous Generation

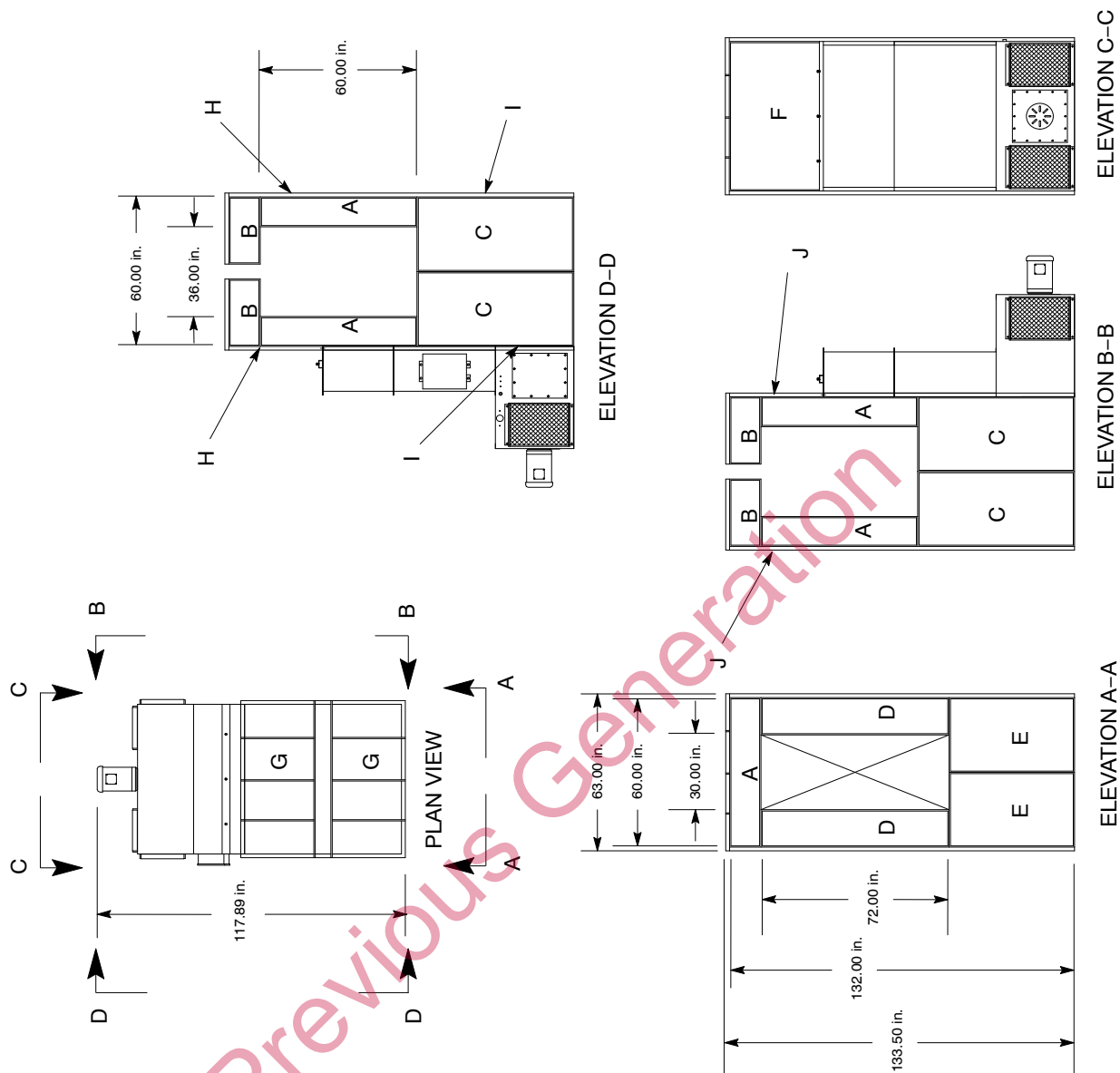

Figure 4-25 Model 5300C7 Assembly Drawing

Model 5300C8

Refer to Table 4-25 and Figure 4-26.

Table 4-25 Model 5300C8

Item	Description	Dimensions, in.	Quantity
A	Wall panel	12 x 60	5
B	Wall panel	12 x 27	4
C	Wall panel	30 x 66	4
D	Wall panel	15 x 72	2
E	Wall panel	30 x 54	2
F	Wall panel	42 x 60	1
G	Roof panel	28.5 x 63	2
H	Bracket	72	2
I	Hinge	66	2
J	Bracket	138	2
—	Collector module	96.1 x 65.5 x 54.0	1

Previous Generation

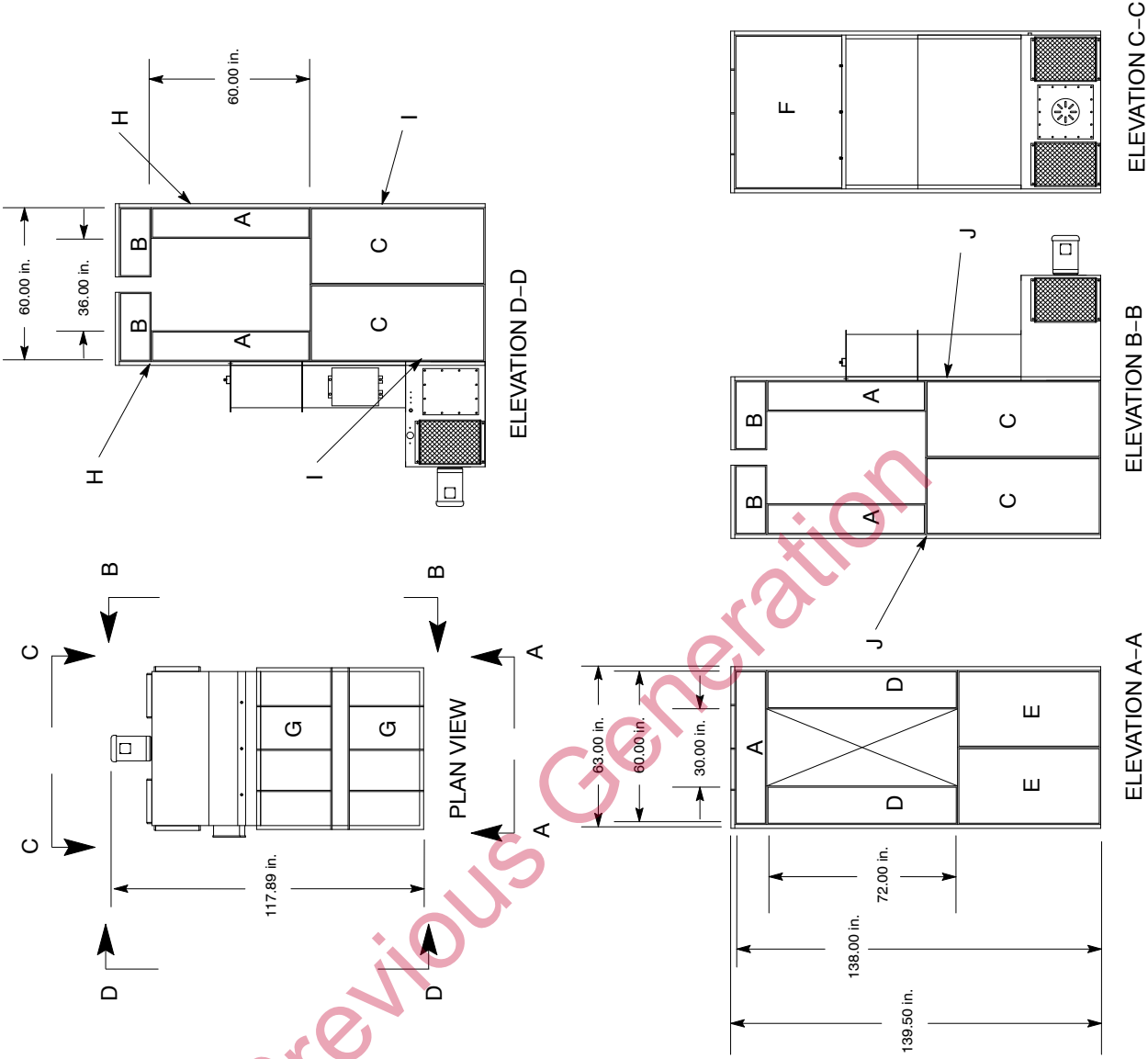

Figure 4-26 Model 5300C8 Assembly Drawing

Model 5300C9

Refer to Table 4-26 and Figure 4-27.

Table 4-26 Model 5300C9

Item	Description	Dimensions, in.	Quantity
A	Wall panel	12 x 60	5
B	Wall panel	12 x 27	4
C	Wall panel	30 x 72	4
D	Wall panel	15 x 72	2
E	Wall panel	30 x 60	2
F	Wall panel	30 x 48	2
G	Roof panel	28.5 x 63	2
H	Bracket	72	2
I	Hinge	72	2
J	Bracket	144	2
—	Collector module	96.1 x 65.5 x 54.0	1

Previous Generation

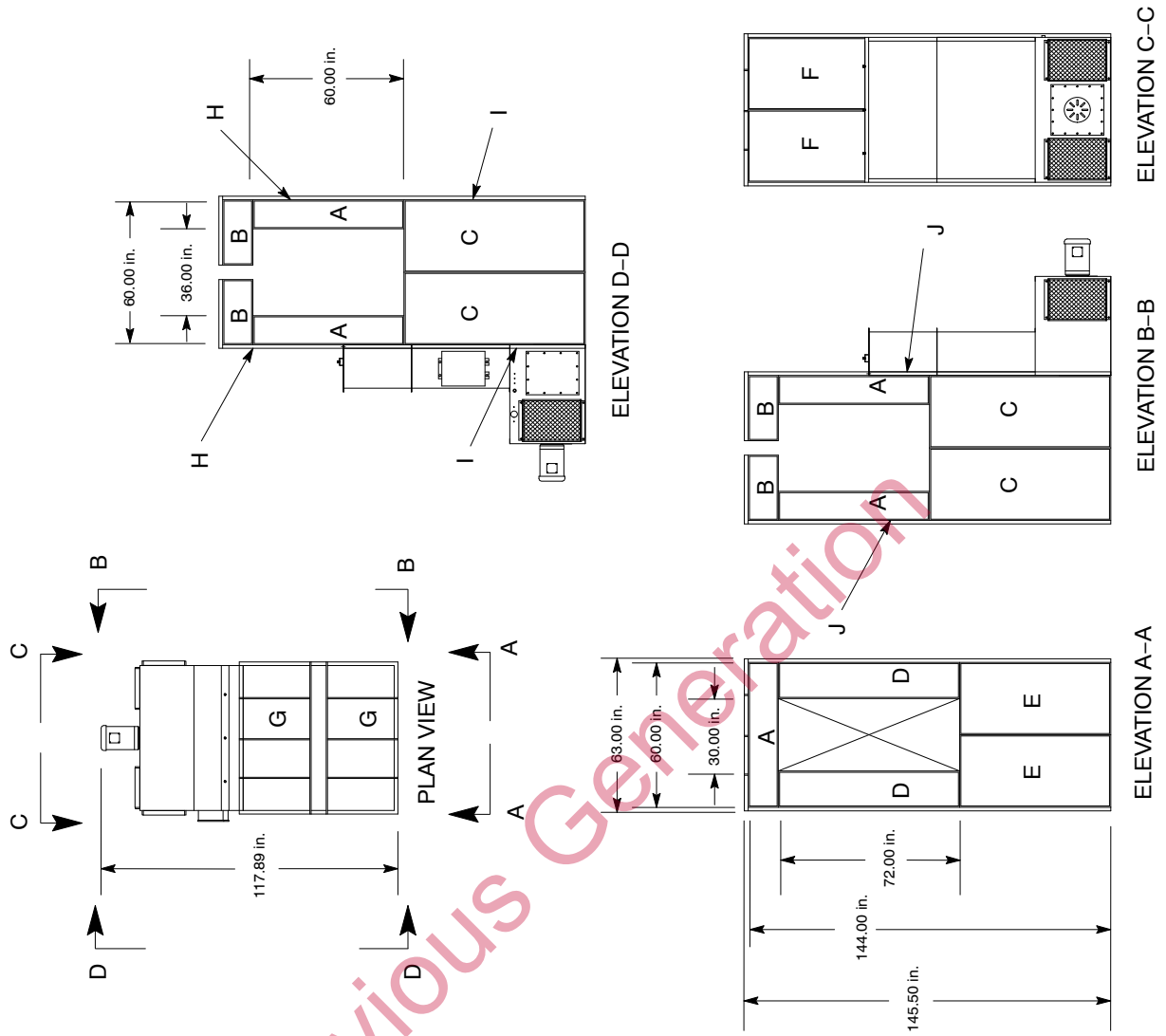

Figure 4-27 Model 5300C9 Assembly Drawing

6000-cfm Conveyor Booths

Use the following bills of materials and assembly drawings to assemble a 6000-cfm conveyor booth.

Model 6000C3

Refer to Table 4-27 and Figure 4-28.

Table 4-27 Model 6000C3

Item	Description	Dimensions, in.	Quantity
A	Wall panel	15 x 60	4
B	Wall panel	12 x 27	4
C	Wall panel	30 x 36	4
D	Wall panel	12 x 60	2
E	Wall panel	15 x 72	4
F	Wall panel	24 x 60	2
G	Wall panel	30 x 108	2
H	Roof panel	28.5 x 123	2
I	Bracket	72	2
J	Hinge	36	2
K	Bracket	108	2
L	Roof support	36 x 23 x 8	1
—	Collector module	109.6 x 65.5 x 54.0	1

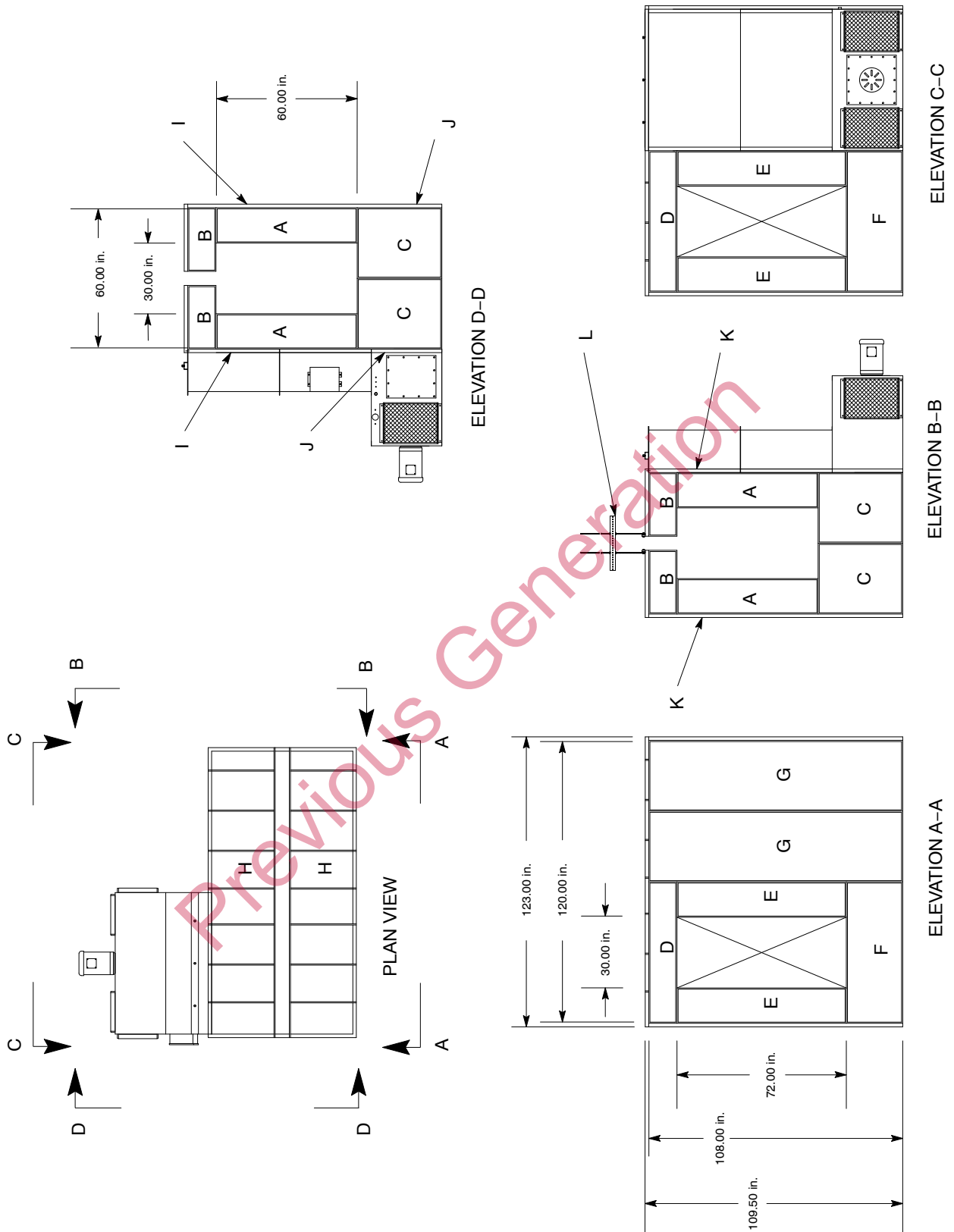

Figure 4-28 Model 6000C3 Assembly Drawing

Model 6000C4

Refer to Table 4-28 and Figure 4-29.

Table 4-28 Model 6000C4

Item	Description	Dimensions, in.	Quantity
A	Wall panel	15 x 60	4
B	Wall panel	12 x 27	4
C	Wall panel	30 x 42	4
D	Wall panel	12 x 60	2
E	Wall panel	15 x 72	4
F	Wall panel	30 x 60	2
G	Wall panel	30 x 114	2
H	Wall panel	6 x 60	1
I	Roof panel	28.5 x 123	2
J	Bracket	72	2
K	Hinge	42	2
L	Bracket	114	2
M	Roof support	36 x 23 x 8	1
—	Collector module	108.1 x 65.5 x 54.0	1

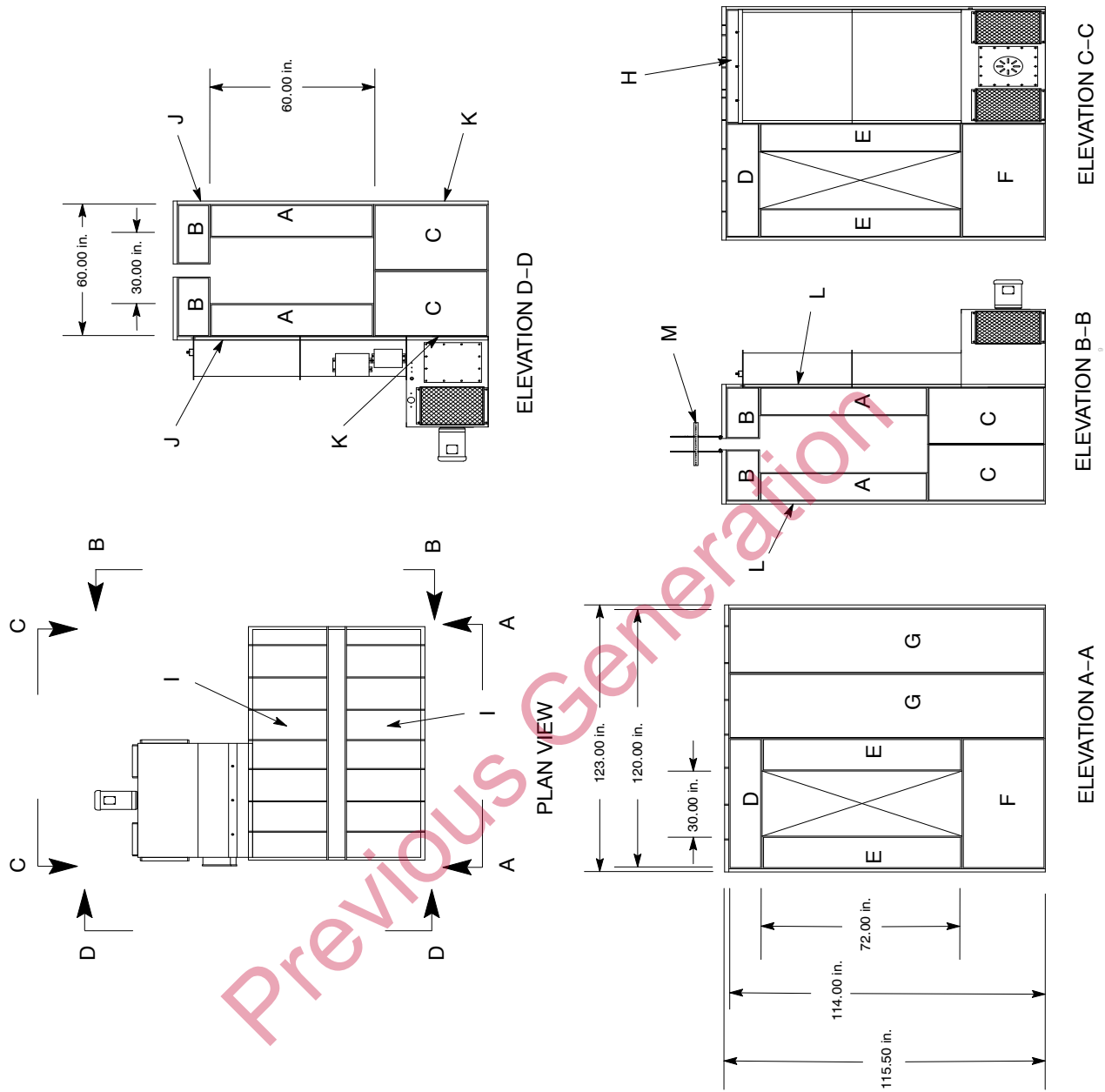

Figure 4-29 Model 6000C4 Assembly Drawing

Model 6000C5

Refer to Table 4-29 and Figure 4-30.

Table 4-29 Model 6000C5

Item	Description	Dimensions, in.	Quantity
A	Wall panel	15 x 60	4
B	Wall panel	12 x 27	4
C	Wall panel	30 x 48	4
D	Wall panel	12 x 60	2
E	Wall panel	15 x 72	4
F	Wall panel	36 x 60	2
G	Wall panel	30 x 120	2
H	Wall panel	12 x 60	1
I	Roof panel	28.5 x 123	2
J	Bracket	72	2
K	Hinge	48	2
L	Bracket	120	2
M	Roof support	36 x 23 x 8	1
—	Collector module	108.1 x 65.5 x 54.0	1

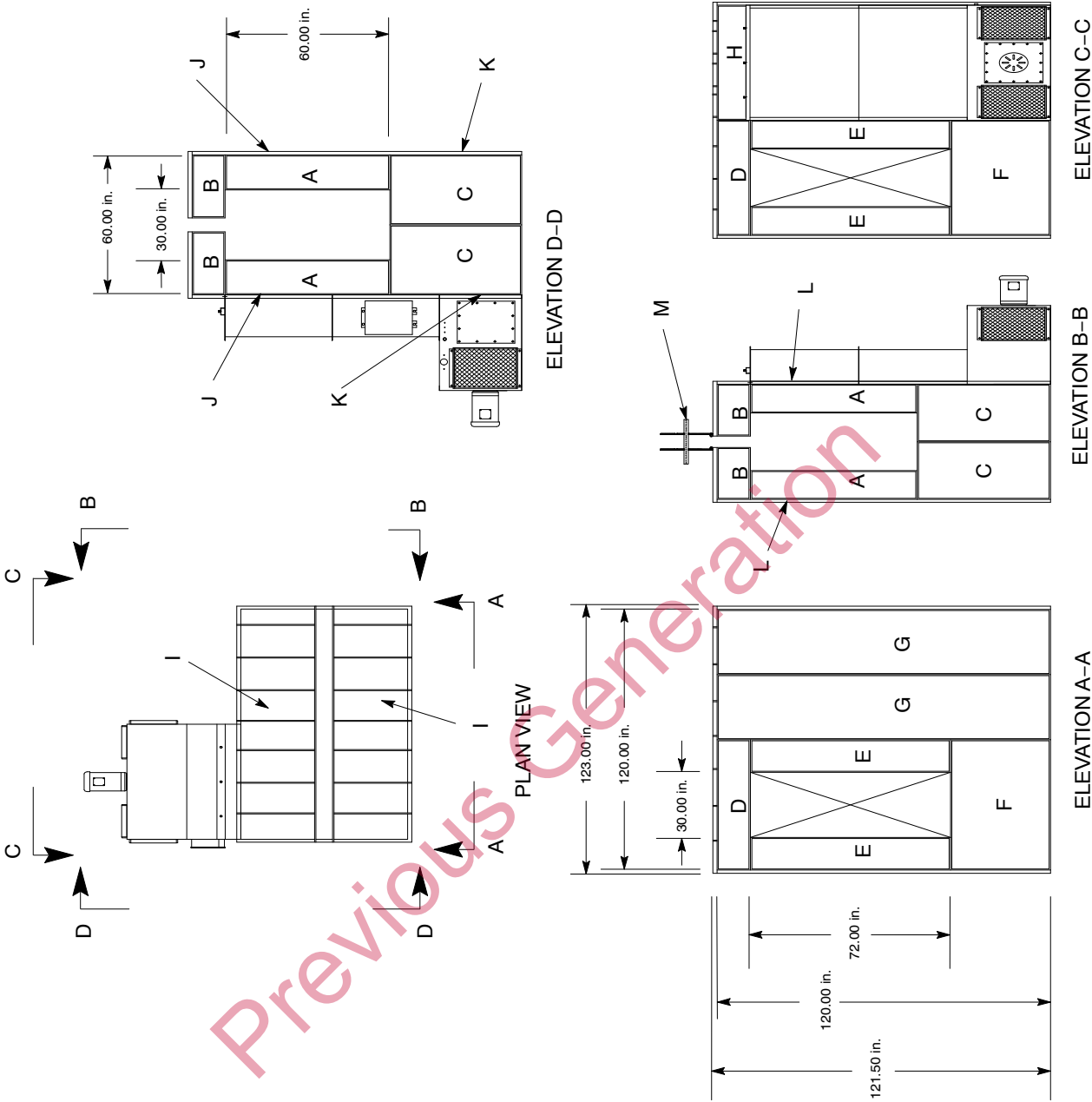

Figure 4-30 Model 6000C5 Assembly Drawing

Model 6000C6

Refer to Table 4-30 and Figure 4-31.

Table 4-30 Model 6000C6

Item	Description	Dimensions, in.	Quantity
A	Wall panel	15 x 60	4
B	Wall panel	12 x 27	4
C	Wall panel	30 x 54	4
D	Wall panel	12 x 60	2
E	Wall panel	15 x 72	4
F	Wall panel	42 x 60	3
G	Wall panel	30 x 84	2
H	Wall panel	18 x 60	1
I	Roof panel	28.5 x 123	2
J	Bracket	72	2
K	Hinge	54	2
L	Bracket	126	2
M	Roof support	36 x 23 x 8	1
—	Collector module	108.1 x 65.5 x 54.0	1

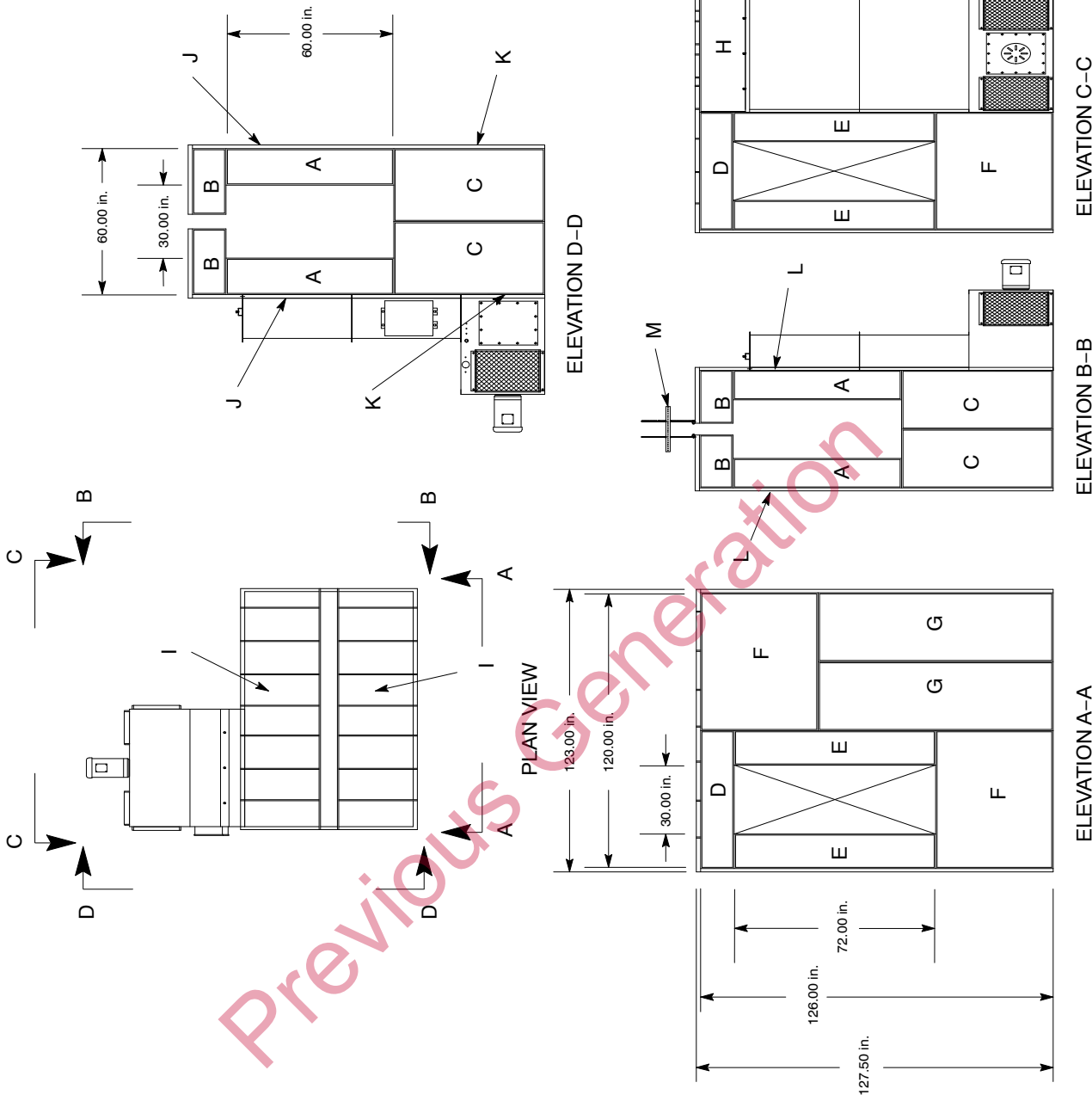

Figure 4-31 Model 6000C6 Assembly Drawing

Model 6000C7

Refer to Table 4-31 and Figure 4-32.

Table 4-31 Model 6000C7

Item	Description	Dimensions, in.	Quantity
A	Wall panel	15 x 60	4
B	Wall panel	12 x 27	4
C	Wall panel	30 x 60	4
D	Wall panel	12 x 60	2
E	Wall panel	15 x 72	4
F	Wall panel	30 x 48	6
G	Wall panel	30 x 84	2
H	Wall panel	24 x 60	1
I	Roof panel	28.5 x 123	2
J	Bracket	72	2
K	Hinge	60	2
L	Bracket	132	2
M	Roof support	36 x 23 x 8	1
—	Collector module	108.1 x 65.5 x 54.0	1

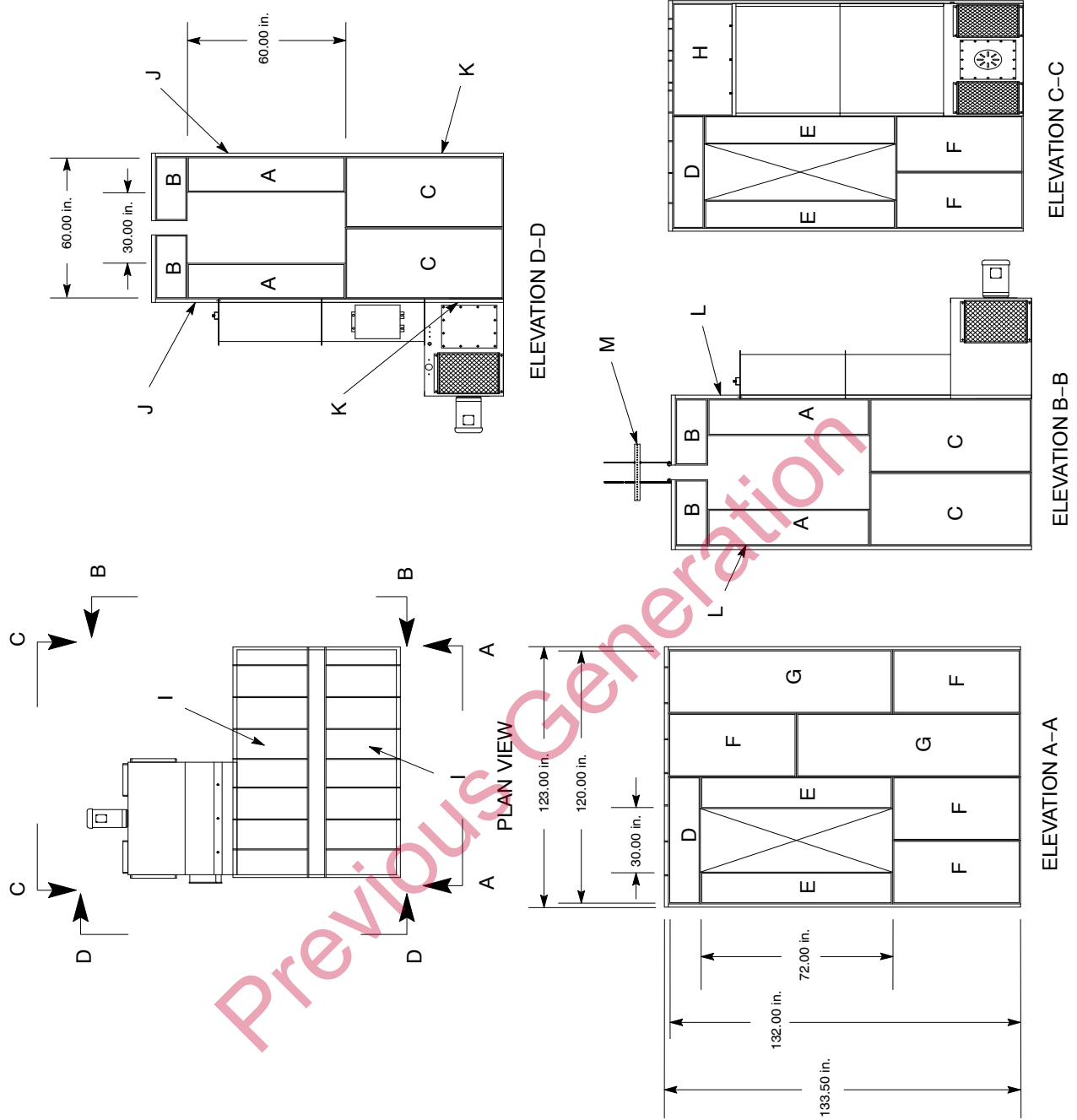

Figure 4-32 Model 6000C7 Assembly Drawing

Model 6000C8

Refer to Table 4-32 and Figure 4-33.

Table 4-32 Model 6000C8

Item	Description	Dimensions, in.	Quantity
A	Wall panel	15 x 60	4
B	Wall panel	12 x 27	4
C	Wall panel	30 x 66	4
D	Wall panel	12 x 60	2
E	Wall panel	15 x 72	4
F	Wall panel	30 x 54	6
G	Wall panel	30 x 84	2
H	Wall panel	30 x 60	1
I	Roof panel	28.5 x 123	2
J	Bracket	72	2
K	Hinge	66	2
L	Bracket	138	2
M	Roof support	36 x 23 x 8	1
—	Collector module	108.1 x 65.5 x 54.0	1

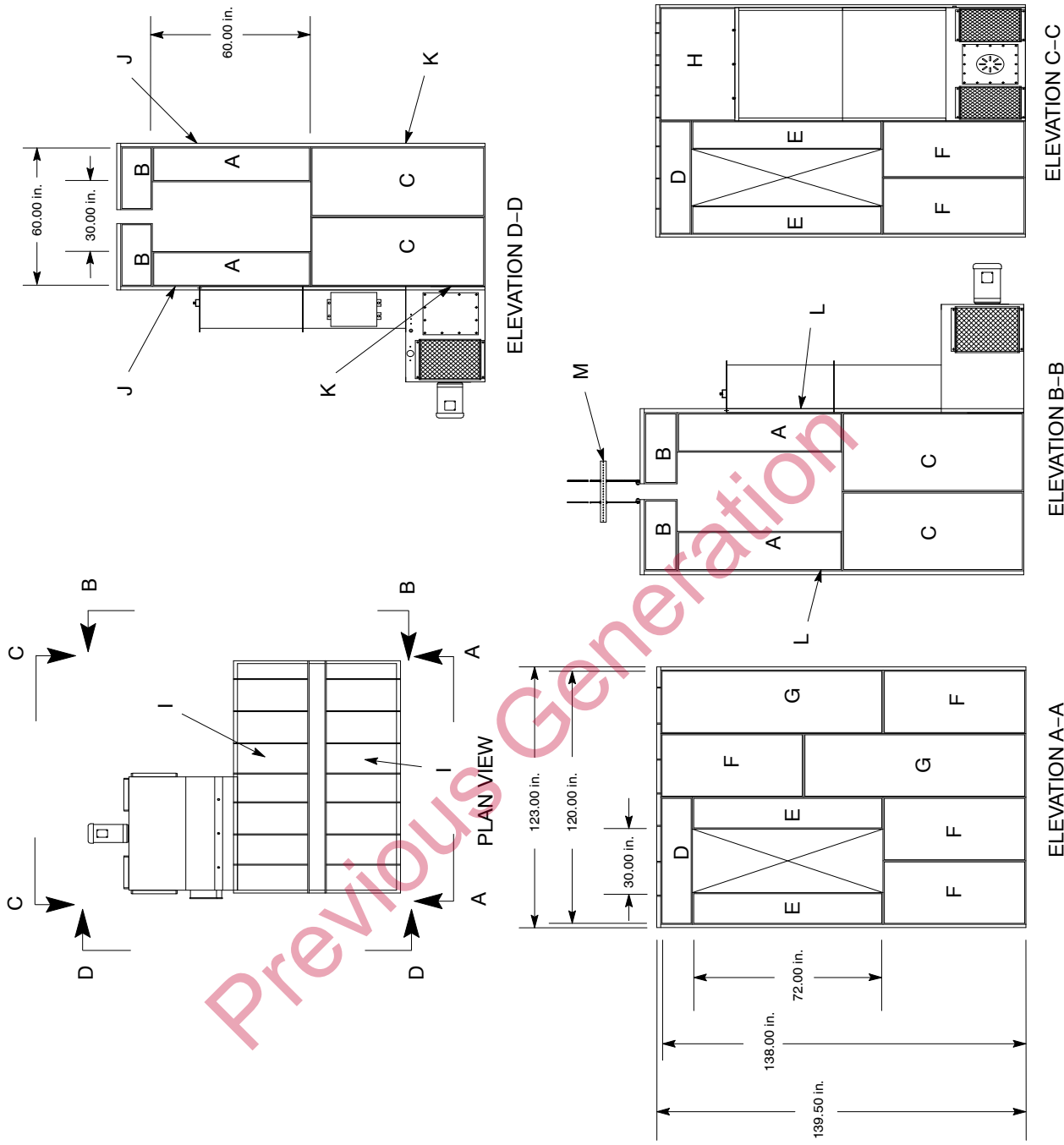

Figure 4-33 Model 6000C8 Assembly Drawing

Model 6000C9

Refer to Table 4-33 and Figure 4-34.

Table 4-33 Model 6000C9

Item	Description	Dimensions, in.	Quantity
A	Wall panel	15 x 60	4
B	Wall panel	12 x 27	4
C	Wall panel	30 x 72	4
D	Wall panel	12 x 60	2
E	Wall panel	15 x 72	4
F	Wall panel	30 x 60	6
G	Wall panel	30 x 84	2
H	Wall panel	36 x 60	1
I	Roof panel	28.5 x 123	2
J	Bracket	72	2
K	Hinge	72	2
L	Bracket	144	2
M	Roof support	36 x 23 x 8	1
—	Collector module	108.1 x 65.5 x 54.0	1

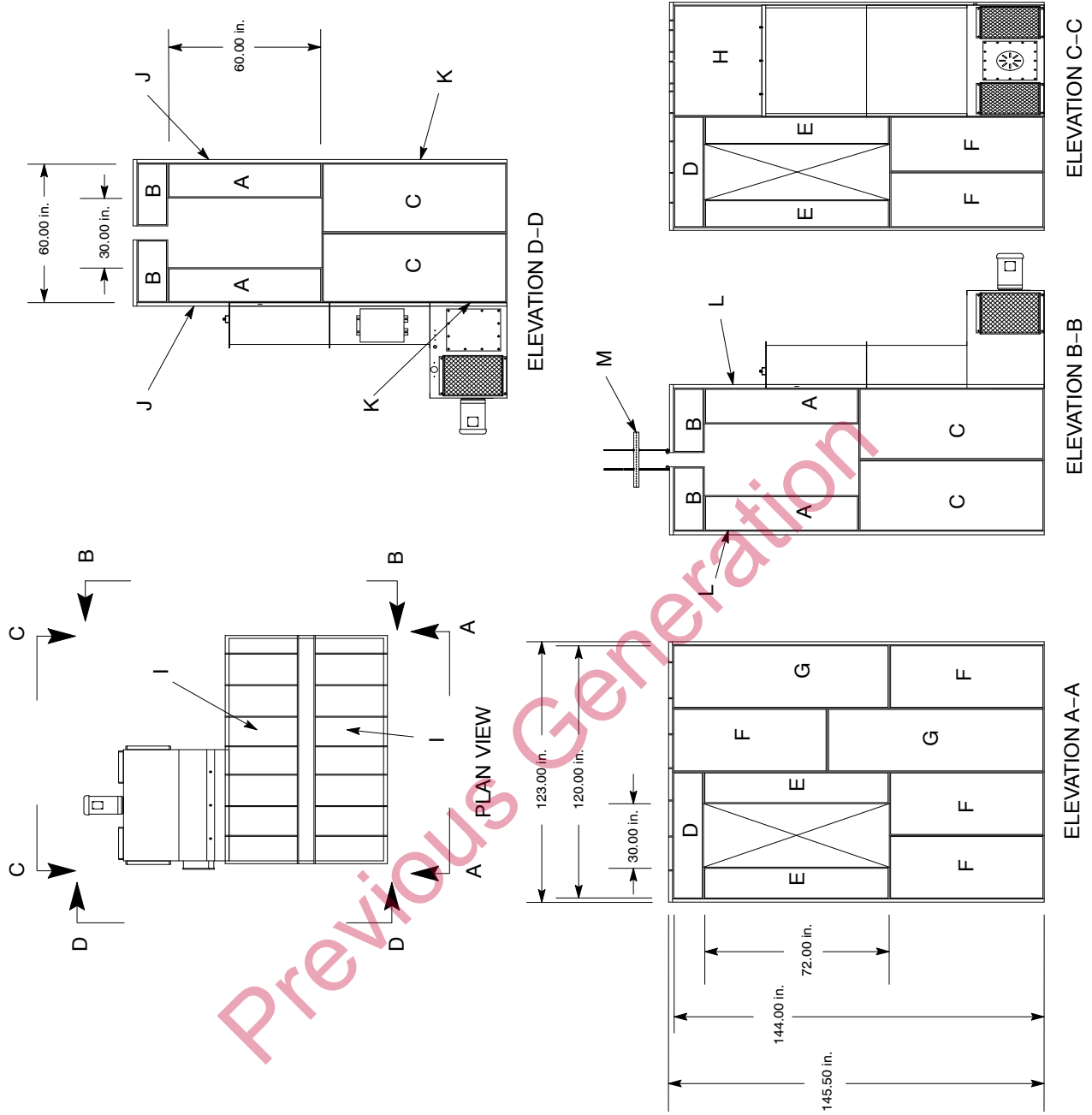

Figure 4-34 Model 6000C9 Assembly Drawing

Previous Generation

Section 5

Operation



WARNING: Allow only qualified personnel to perform the following tasks. Follow the safety instructions in this document and all other related documentation.



WARNING: This equipment can be dangerous unless it is used in accordance with the rules laid down in this manual.

Introduction



WARNING: Keep gun controllers and/or electrostatic power units outside the booth while spraying powder. Failure to observe this warning will result in a hazardous situation and is a violation of safety codes.



WARNING: All conductive equipment in the spray area must be connected to a true earth ground. Ungrounded equipment can become electrostatically charged and generate a spark hot enough to cause ignition upon discharge.

This section provides basic operating procedures for the booth. Refer to your powder application equipment manuals for operation instructions for other system components.

Preparation

Make sure that the following conditions are met before operating the booth:

- the fan motor is rotating in the correct direction
- the system has no air leaks
- the spray room and powder booth are clean and free of all dust and dirt
- there is a sufficient amount of each color of powder to be used
- personnel are trained in the operation and maintenance of all components of the powder application system
- the fire detection system is working properly

NOTE: Fire detection systems are required when automatic or unattended spray operations are performed. Refer to the appropriate fire detection system manual for installation and operating procedures.

Initial Startup

Use the following procedure to startup a new powder booth and season the cartridge filters.

1. Turn the main disconnect switch on the electrical panel(s) to the on position.
2. Supply compressed air to the booth.
3. Start the exhaust fan by pressing the EXHAUSTER START button on each control panel.
4. Record an initial reading of the face velocity of the booth with a hand-held velometer.
5. Record the current reading on the final filter differential pressure gauge.
6. Begin spraying powder into the booth under normal operating conditions.
7. Continue to take readings with a hand-held velometer until the face velocity of the booth reaches $\frac{1}{2}$ of the initial value recorded at startup.
8. Adjust the air supply regulator to 2 bar (25 psi). The pulsing of the cartridge filters will be audible every 90 seconds.
9. Continue to take readings with a hand-held velometer until the face velocity of the booth again reaches $\frac{1}{2}$ of the initial value recorded at startup.

NOTE: Maintain booth face velocity at 100 fpm during normal system operation.

10. Adjust the air supply regulator to 4 bar (55 psi).

Daily Startup

1. Turn the main disconnect switch on the electrical panel(s) to the on position.
2. Supply compressed air to the booth.
3. Start the exhaust fan by pressing the EXHAUSTER START button on each control panel.
4. Begin spraying powder into the booth under normal operating conditions.

NOTE: Maintain the booth face velocity at 100 fpm during normal system operation.

Shutdown

Follow this procedure to shut down the Econo-Coat booth.

1. Turn off the gun controller and ground the gun electrode.
2. Clean the booth interior.
3. Turn off the exhaust fans by pressing the EXHAUSTER STOP button on each control panel.
4. Turn the main disconnect switch on the main electrical panel(s) to the off position.
5. Perform daily preventative maintenance procedures as described in *Maintenance* in this section of this manual and your powder application equipment manuals.

Maintenance

The following tables explain the preventive maintenance procedures for your Econo-Coat booth equipment. Refer to your powder application equipment manuals for additional maintenance procedures.

Daily Maintenance

Table 5-1 Daily Maintenance

Equipment	Maintenance Procedure
Booth enclosure	Clean the booth enclosure using the following steps: <ol style="list-style-type: none"> 1. Clean the booth interior with a rubber squeegee or other grounded, non-sparking device. 2. Remove collected powder from the booth for reclaim or disposal.
Powder spray guns	Clean the spray guns by following the instructions in the spray gun manuals. Replace worn parts as necessary. Test resistance as directed in the spray gun manuals.
Powder pumps	Disassemble and clean the pumps by following the instructions in the pump manuals. Replace worn parts as necessary.
Compressed air	Open the drop leg drain valve and use a clean, white cloth to check for water, oil, or other contaminants. If you find contaminants, correct the problem before resuming spray operations. Check and correct the regulator settings.
Air dryers and filters	Clean and drain the filters. Check the air dryer for proper operation.
Grounds	Check all equipment grounds. Clean and strip all part hangers. Resistance between parts to be sprayed and ground should be less than one megohm at 500 volts.
Fire Detection System (Optional)	<ol style="list-style-type: none"> 1. Test the operation of the fire detection system. The spray booth, spray devices, and conveyor should be disabled when the fire alarm activates. 2. Clean the detector lenses and the reflecting rings. Refer to the appropriate fire detection system manual.

Periodic Maintenance

Table 5-2 Periodic Maintenance

Equipment	Maintenance Procedure
Electrical connections	Tighten all electrical connections and inspect for loose or broken wires.
Spray guns and electrostatic cables (if used)	Check the spray gun resistor and electrostatic cable resistance with a megohm meter as described in the spray gun manual.
Powder feed hose	Disconnect the powder feed hose from the powder pump, and with the booth fans on, blow out the hose. Replace the feed hose if it is worn or there is impact fusion present.
Cartridge filters	Visually check the cartridge filters for damage. Remove the final filters and check the inside of the fan housing. Signs of powder inside the fan housing indicate a leaking cartridge. Check the cartridge filter gaskets and sealing surfaces.
Final filters	<p>With the exhaust fans running, check the differential pressure gauges on the modules.</p> <p>If the pressure drop across the final filters in any one module reaches 5.0-in. wc, that module's exhaust fan will automatically shut down. Power to the pulse valve solenoids and electrostatic power supplies, if connected to the booth control panel, also will be disabled. A reading of 4.0-in. wc or higher indicates that the final filters are clogged.</p> <p>If the final filters clog, disconnect and lock out the power to the system. Clean or replace the final filters. Check the cartridge filter media and gaskets for damage. Replace the cartridge filters if necessary.</p>
Fan motor	<p>Lubricate the fan motor bearings monthly with one of the following greases: Dolium R (Shell), SRI No. 2 (Chevron), Rykon Premium #2 (Amoco), or Polyrex #2 (Texaco).</p> <p>Shut off the exhaust fans and disconnect and lock out power to the system. Using a grease gun, apply two full strokes of grease to each clean grease fitting. Do not over-grease.</p>

Section 6

Troubleshooting



WARNING: Allow only qualified personnel to perform the following tasks. Follow the safety instructions in this document and all other related documentation.

Introduction



WARNING: Disconnect and lock out electrical power to the system before removing any panels or performing any repair procedures.

These procedures cover only the most common problems that you may encounter. If you cannot solve the problem with the information given here, contact your local Nordson representative for help.

No.	Problem	Page
1.	Inadequate or intermittent flow of powder from spray guns; surging or spitting	6-2
2.	Problems with powder coating: uniformity, edge coverage, film build, wrap, penetration in recesses	6-3
3.	Powder escaping from booth openings	6-4
4.	System shuts down or will not start	6-5
5.	Cartridge pulsing will not start	6-5

Troubleshooting Charts

Use the following charts to diagnose and correct common problems.

Problem	Possible Cause	Corrective Action
1. Inadequate or intermittent flow of powder from spray guns; surging or spitting	Poor powder fluidization in feed hopper	Adjust the fluidizing air pressure. Check for moisture or oil in the air supply. Check the powder supply for contamination or large clumps of powder.
	Low powder level in feed hopper	Add powder to the hopper.
	Clogged powder pump	Disassemble the pump. Clean and inspect the venturi nozzle and throat. Replace if necessary.
	Worn parts	Check the pump mounting O-rings and replace them if damaged.
	Clogged pickup tube or pump air supply lines	Check for obstructions in the pickup tube or air tubing.
	Obstruction in powder feed hose, or hose too long	<ol style="list-style-type: none"> 1. Make sure the exhaust fans are operating. 2. Turn off the electrostatic power and disconnect the powder feed hose from the spray gun. 3. Trigger the spray gun and look for smooth powder flow from the feed hose. 4. Disconnect the feed hose at the pump and blow it out with compressed air. 5. Eliminate any kinks, severe bends, pinching, or any cause of impact fusion from the feed hose. Replace the feed hose if impact fusion is restricting flow. 6. Reduce the length of the feed hose to 7.6 m (25 ft) maximum, with a vertical rise of no more than 2.75 m (9 ft).

Continued...

Problem	Possible Cause	Corrective Action
1. Inadequate or intermittent flow of powder from spray guns; surging or spitting (contd)	Severe tribo-charging in powder feed hose	Contact your Nordson representative for an alternative feed hose material. Review the problem with the powder coating manufacturer.
	Obstruction in spray gun	Refer to your spray gun manual. Disassemble the spray gun and clean it. Replace any worn parts. Check all clearances when reassembling the spray gun.
	Incorrect flow rates or atomizing air pressures	Adjust the air pressure settings. Maintain the correct flow rate-to-atomizing air pressure ratio. If less than 1.4 bar (20 psi) is needed to deliver the proper flow rate for your application, install a low-flow kit on your powder spray equipment. Refer to your spray equipment manual or contact your Nordson representative for part numbers and ordering information.
	Low kV output	Increase the kV setting. Refer to your spray gun controller or power supply manual.
2. Problems with powder coating: uniformity, edge coverage, film build, wrap, penetration in recesses	Poor workpiece ground (greater than one megohm resistance)	Clean the hangers, fixtures, and hooks.
	Incorrect spray gun position	Refer to the spray gun manual for suggested spray gun position.
	Incorrect flow rate or atomizing air pressure	Change the flow rate air pressure to increase or decrease powder flow. Change the atomizing air pressure to alter the fan pattern and power distribution.
	Incorrect voltage setting	Adjust the kV settings as directed in the spray gun manual.
	Incorrect spray gun nozzle for application	Contact your Nordson representative for the proper nozzle for your application.
	Wrong powder for application	Contact your powder supplier or your Nordson representative.
<i>Continued...</i>		

Troubleshooting Charts *(contd)*

Problem	Possible Cause	Corrective Action
3. Powder escaping from booth openings	Cartridge filter gaskets not sealing properly	Check the differential pressure gauges. A reading approaching 5.0-in. wc means that the final filters are clogging. At 5.0-in. wc, the module exhaust fan will shut down. Remove the cartridges and clean the gaskets and sealing surfaces. Install them, checking the gasket alignment and sealing. Refer to <i>Cartridge Filter Replacement</i> in the <i>Repair</i> section for filter replacement instructions.
	Damaged cartridge filter media	Replace the cartridge filters.
	Cartridge filters clogged due to:	
	• Inadequate pulse pressure	Increase the manifold air pressure to 4–7 bar (60–100 psi).
	• Pulse-off time too long	Decrease the pulse-off time at the timer board inside the control panel.
	• Powder too fine or contaminated	If using reclaimed powder, reduce the ratio of reclaimed-to-virgin powder. Check powder particle size, if necessary.
	• Powder contaminated	Replace the contaminated powder.
	• Pulse valve diaphragm is ruptured	If you hear a hissing sound inside the fan section, check for constant air flow from the valve. Rebuild or replace the damaged valve. Refer to <i>Pulse Valve Replacement</i> in the <i>Repair</i> section.
	• Pulse valve spring broken, or solenoid valve not triggering pulse valve	<ol style="list-style-type: none"> 1. When the cartridges pulse, note any filters not being pulsed. 2. Check the pulse valve air tubing and solenoid wiring; correct if disconnected or failed. 3. Turn off and lock out power. Check the continuity across the solenoid terminal. If it is shorted open, replace the solenoid. If it is not shorted open, replace the pulse valve.
Cross drafts	Check for cross drafts across the booth openings and correct as necessary.	
Parts entering booth are too hot	Cool the parts to 48 °C (120 °F) or below before bringing them into the booth.	

Continued...

Problem	Possible Cause	Corrective Action
	Powder flow exceeds ability of exhaust fans to contain	Reduce the powder flow or the number of spray guns.
3. Powder escaping from booth openings (contd)	Booth openings exceed design criteria	<p style="text-align: right;"><i>Continued...</i></p> Close off or decrease the size of the opening.
	Parts too large, interrupting flow of air through booth	Contact your Nordson representative.
	Exhaust fan rotation reversed	Reverse the rotation of the motor by switching the wiring.
4. System shuts down or will not start	Final filter pressure switch (PS111) trips	Clogged final filters are causing a high differential pressure. Check for a powder leak through the cartridge filters and correct it as necessary. The differential pressure switch setting is incorrect or the switch failed. Adjust the setting or replace the switch.
	Fuse(s) blown	Check for the reason the fuse(s) blew and correct it. Replace the blown fuse(s).
	Fan motor overload shutdown	Correct one of the following possible motor, contactor, fuse, or operational problem as needed: <ul style="list-style-type: none"> • Check the exhaust fan for proper rotation direction. • Check for mechanical binding of the motor/fan assembly. • Check for contact corrosion at the motor starters (M111, in the control panel). • Check the overload protectors for failure (OL111 in the control panel).
	Incorrect, shorted, or open electrical wiring	Check the electrical circuits.
	Optional fire detection system	Check the fire detection system fuses. Refer to the appropriate fire detection system manual.
	5. Cartridge pulsing will not start	No air supply to pulse manifolds
Solenoid shorted; blows timer board fuse		Call an electrician.
Timer board malfunction or other electrical problem		Call an electrician.

Previous Generation

Section 7

Repair



WARNING: Allow only qualified personnel to perform the following tasks. Follow the safety instructions in this document and all other related documentation.

Introduction



WARNING: Disconnect and lock out electrical power to the system before removing any panels or performing any repair procedures. Shut off the electrostatic equipment and ground the spray gun electrode.



WARNING: System or material pressurized. Relieve system air pressure before disconnecting any air lines.

This section provides common repair procedures for Econo-Coat booths. Refer to the *Parts* section to order replacement parts listed in this section.

Cartridge Filter Replacement



WARNING: Wear an OSHA-approved respirator while you are cleaning the booth.



CAUTION: Use only Nordson-approved cartridge filters. Using unapproved filters may cause equipment damage and void factory warranties.

NOTE: There are two types of cartridge filters:

- **Flow-Through:** These filters have a large hole on both ends.
- **Closed-End:** These filters have a large hole on one end only.

NOTE: The 1000 and 2000-cfm batch booths do not use flow-through cartridge filters. Only one or two closed-end cartridge filters are used.

See Figure 7-1.

1. Unscrew the push plate bolt (1) until the push plate (2) is against the top of the collector module.

Cartridge Filter Replacement *(contd)*

2. Remove the old cartridge filters from the booth.
3. Remove the new cartridge filters from their cartons and inspect them for damage. Do not install damaged filters.
4. Install the flow-through cartridge filter (4) over the large hole in the fan section with the bottom of the cartridge filter against the alignment pins.
5. Set the closed-end cartridge filter (3) on top of the flow-through cartridge filter and align both filters.
6. Center the push plate over the end cap of the closed-end cartridge filter.



CAUTION: Do not over tighten the push plate bolt. Over tightening the bolt may cause cartridge filter damage.

7. Tighten the push plate bolt until the cartridge filter gasket is compressed to $\frac{7}{16}$ in.

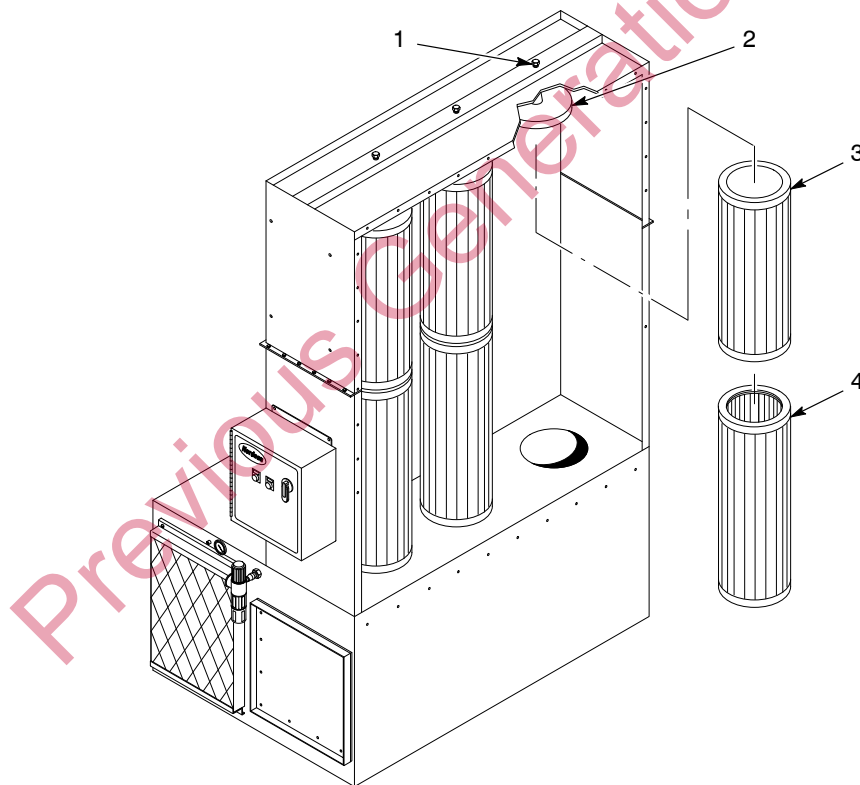

Figure 7-1 Cartridge Filter Replacement (Typical)

- | | |
|--------------------|----------------------------------|
| 1. Push plate bolt | 3. Closed-end cartridge filter |
| 2. Push plate | 4. Flow-through cartridge filter |

Final Filter Replacement

See Figure 7-2.

1. Remove the upper Z-bracket (1) and loosen the lower Z-bracket (3).
2. Remove the old final filter (2) from the fan section.
3. Remove the new final filter from its carton. Inspect the filter media, frame, and gasket for damage. Do not use damaged filters.
4. Place the final filter, gasket side inward, onto the lower Z-bracket and line up the gasket with the edges of the holes in the collector module.
5. Install the upper Z-bracket and tighten both Z-brackets to evenly compress the gasket. Inspect the gasket to make sure that it is properly sealed and aligned.

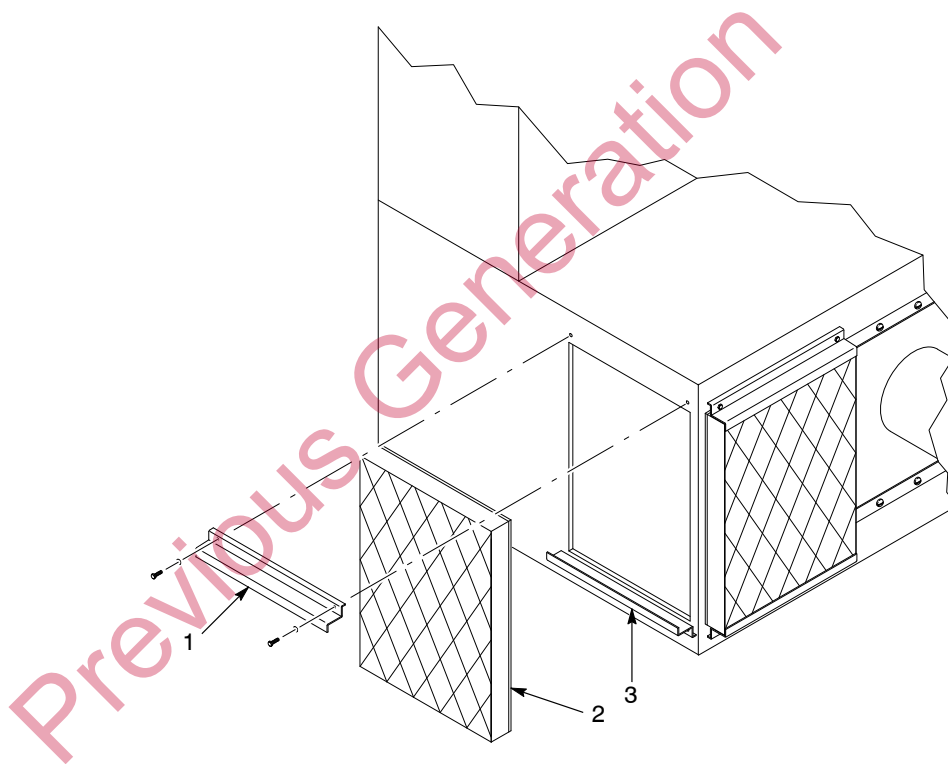

Figure 7-2 Final Filter Replacement

- | | |
|--------------------|--------------------|
| 1. Upper Z-bracket | 3. Lower Z-bracket |
| 2. Final filter | |

Pulse Valve Replacement



WARNING: Disconnect and lock out electrical power before performing the following procedure. The interior of the fan section contains moving parts that can cause serious personal injury.



WARNING: Relieve system pressure before servicing. Failure to observe this warning could result in serious injury.

Removing the Pulse Valve

See Figure 7-3.

1. Disconnect and lock out the system electrical power. Shut off the main air supply and relieve system air pressure.
2. Remove the screws (9) from the access panel (8). Remove the access panel; be careful not to damage the gasket (7).
3. Disconnect the pilot air tubing (5) from the pulse valve elbow fitting (4).
4. Unscrew the pulse valve (2) from the manifold nipple (3).
5. Remove the nozzle (1) and elbow fitting from the old pulse valve.

Installing the Pulse Valve

See Figure 7-3.

1. Clean the threads of the manifold nipple (3), nozzle (1), and elbow fitting (4). Wrap the threads with 2–3 layers of PTFE tape.
2. Install the nozzle and elbow fitting on the new pulse valve (2).
3. Screw the new pulse valve on the manifold nipple. Position the valve so that the pulse nozzle points straight up into the center of the cartridge filter.
4. Connect the pilot air tubing (5) to the elbow fitting.
5. Inspect the access panel gasket (7) for damage. Replace the gasket if it is damaged.
6. Secure the access panel (8) to the fan section.

Pulse Valve Replacement *(contd)*

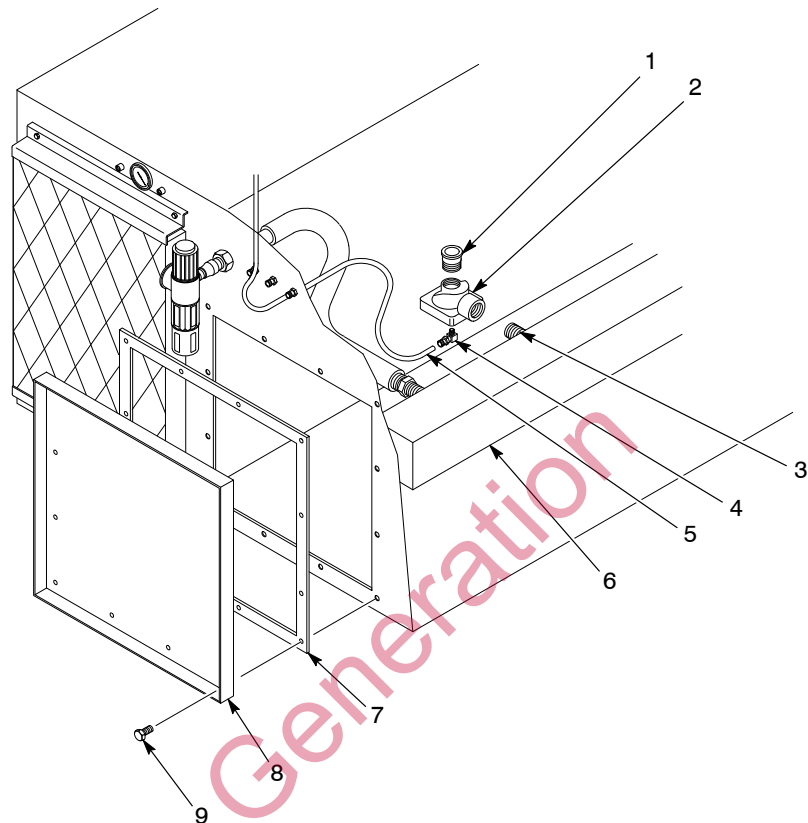

Figure 7-3 Pulse Valve Replacement

- | | |
|---------------------|------------------------|
| 1. Nozzle | 6. Manifold |
| 2. Pulse valve | 7. Access panel gasket |
| 3. Manifold nipple | 8. Access panel |
| 4. Elbow fitting | 9. Screws |
| 5. Pilot air tubing | |

Fan and Motor Replacement



WARNING: Disconnect and lock out electrical power before performing the following procedure. The interior of the fan section contains moving parts that can cause serious personal injury.

Removing the Fan and Motor

See Figure 7-4.

1. Disconnect and lock out system electrical power.
2. Remove the cover from the motor junction box (1) and disconnect the booth wiring from the motor leads. Note the wire colors and numbers so that you can connect them correctly.
3. Disconnect the flexible conduit from the junction box.



WARNING: The fan motor is heavy. Do not attempt to lift it by yourself. Get help or use lifting equipment.

4. Support the motor (2) by either placing blocks of wood between it and the floor or securing lifting equipment to the motor eye bolt.
5. Remove the screws (4) securing the motor plate (5) to the fan section.
6. Carefully pull the entire assembly (motor, plate, and fan) straight out of the fan section and set it on the floor.
7. Loosen the set screw in the fan wheel (8) hub and pull the fan wheel off of the motor shaft. Save the shaft key (3) for reuse.
8. If you are replacing the motor, remove the four screws (7) securing the motor to the motor plate.

Installing the Fan and Motor

See Figure 7-4.

1. Install the new motor (2) onto the motor plate (5), with the junction box (1) oriented as shown in Figure 7-4, using the screws (7).
2. Insert the shaft key (3) into the key way in the new motor shaft.
3. Loosen the set screw in the hub of the new fan wheel (8). Align the slot in the fan wheel hub with the motor shaft key and slide the fan wheel onto the shaft. Torque the fan wheel set screw to 4.0 N•m (36 in.-lb).
4. Inspect the motor plate gasket (6). Replace the gasket if it is damaged.
5. Install the fan and motor assembly into the fan section and secure it with the screws (4).
6. Rotate the fan by hand 360° to make sure it does not rub against the cone. If it does, remove the access panel (See Figure 7-3, (8)), loosen the screws securing the inlet cone, and adjust the cone's position.
7. Remove the motor junction box cover and connect the flexible conduit to the box.
8. Connect the motor leads to the booth wiring according to code and install the junction box cover.
9. Restore system electrical power. Turn on the fan and make sure it is pulling air in through the cartridge filters and out through the final filters. If it is not, turn off the fan, disconnect system electrical power, and reverse any two leads in the motor junction box.

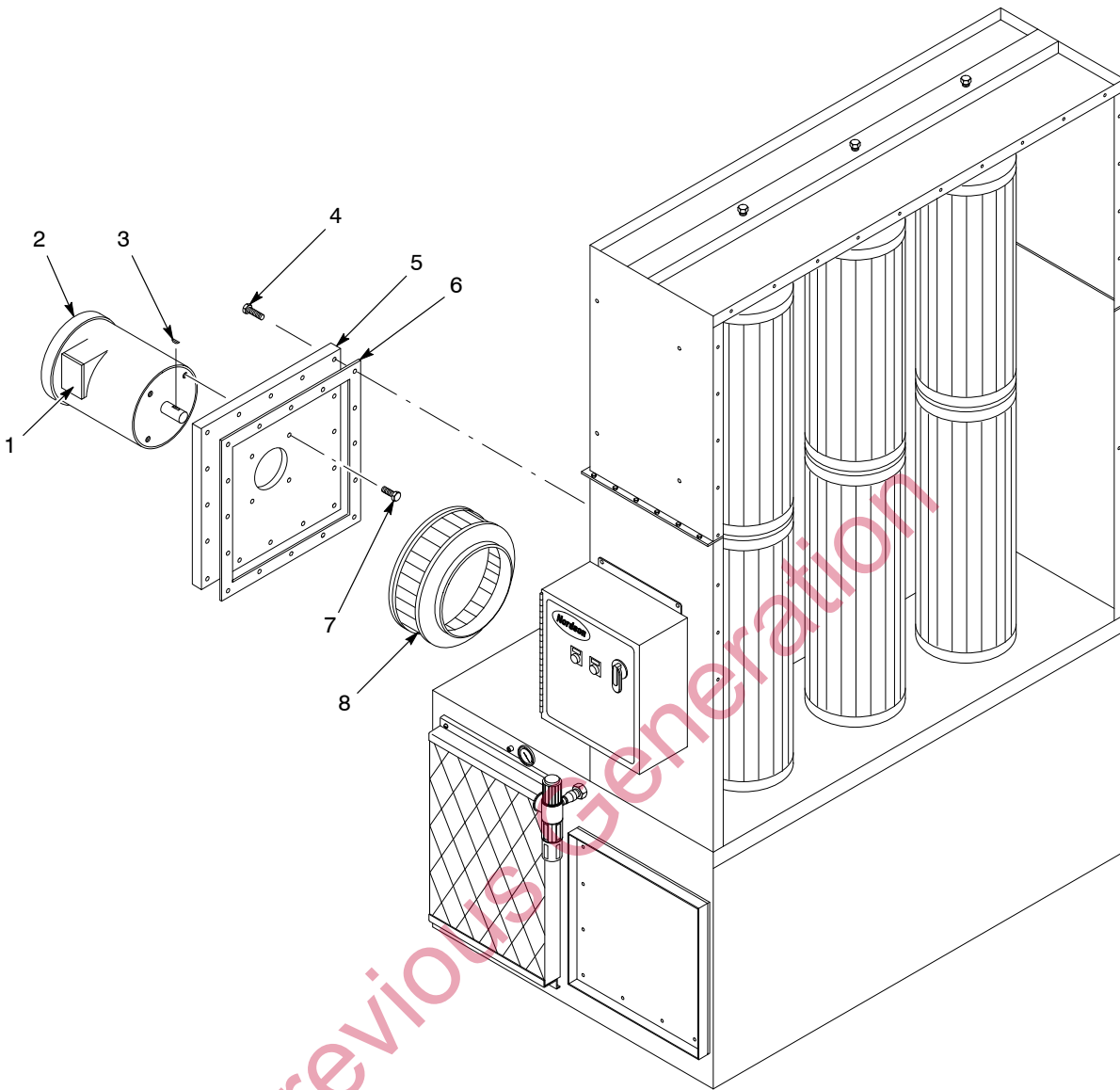

Figure 7-4 Fan and Motor Replacement

- | | | |
|-----------------------|----------------|--------------|
| 1. Motor junction box | 4. Screw | 7. Screw |
| 2. Motor | 5. Motor plate | 8. Fan wheel |
| 3. Shaft key | 6. Gasket | |

Section 8

Parts

Introduction

To order parts, call the Nordson Finishing Customer Support Center at (800) 433-9319 or your local Nordson representative.

Using the Illustrated Parts List

Numbers in the Item column correspond to numbers that identify parts in illustrations following each parts list. The code NS (not shown) indicates that a listed part is not illustrated. A dash (—) is used when the part number applies to all parts in the illustration.

The number in the Part column is the Nordson Corporation part number. A series of dashes in this column (-----) means the part cannot be ordered separately.

The Description column gives the part name, as well as its dimensions and other characteristics when appropriate. Indentions show the relationships between assemblies, subassemblies, and parts.

- If you order the assembly, items 1 and 2 will be included.
- If you order item 1, item 2 will be included.
- If you order item 2, you will receive item 2 only.

The number in the Quantity column is the quantity required per unit, assembly, or subassembly. The code AR (As Required) is used if the part number is a bulk item ordered in quantities or if the quantity per assembly depends on the product version or model.

Letters in the Note column refer to notes at the end of each parts list. Notes contain important information about usage and ordering. Special attention should be given to notes.

Item	Part	Description	Quantity	Note
—	0000000	Assembly	1	
1	000000	• Subassembly	2	A
2	000000	• • Part	1	

Collector Module

Collector Module Assembly

See Figure 8-1.

1000-cfm Module

Item	Part	Description	Quantity	Note
—	-----	MODULE, Econo-Coat, 1000 cfm, 1 phase	1	
1	-----	• TOP PANEL, Econo-Coat, EC1001	1	
3	-----	• SCREW, hex head, serrated, $\frac{3}{8}$ -16 UNC-2A x 1.0	AR	
4	-----	• NUT, hex, serrated, $\frac{3}{8}$ -16 UNC-2B	AR	
5	-----	• PANEL, 39 in., wrapper, EC1001	1	
6	-----	• FAN SECTION, EC1001	1	
7	153134	• CLOSED-END FILTER, 36 in., high efficiency	1	
9	1004667	• PLATE, push, filter, Econo-Coat	1	
NS: Not Shown				
AR: As Required				

2000-cfm Module

Item	Part	Description	Quantity	Note
—	343295	MODULE, Econo-Coat, 2000 cfm, 3 phase	1	
1	343297	• TOP PANEL, Econo-Coat	1	
3	-----	• SCREW, hex head, serrated, $\frac{3}{8}$ -16 UNC-2A x 1.0	52	
4	-----	• NUT, hex, serrated, $\frac{3}{8}$ -16 UNC-2B	36	
5	343298	• PANEL, 39 in., wrapper	1	
6	-----	• FAN SECTION	1	
7	153134	• CLOSED-END FILTER, 36 in., high efficiency	2	
9	1004667	• PLATE, push, filter, Econo-Coat	2	
NS	1006475	• CAP, filter	1	
NS: Not Shown				

3400-cfm Module

See Figure 8-1.

Item	Part	Description	Quantity	Note
—	343292	MODULE, Econo-Coat, 3400 cfm, 3 phase	1	
1	343297	• TOP PANEL, Econo-Coat	1	
2	343306	• PANEL, 27 in., wrapper	1	
3	-----	• SCREW, hex head, serrated, $\frac{3}{8}$ -16 UNC-2A x 1.0 in.	52	
4	-----	• NUT, hex, serrated, $\frac{3}{8}$ -16 UNC-2B	36	
5	343306	• PANEL, 27 in., wrapper	1	
6	-----	• FAN SECTION	1	
7	147162	• FLOW-THROUGH FILTER, 26 in., high efficiency	3	
8	147163	• CLOSED-END FILTER, 26 in., high efficiency	3	
9	1004667	• PLATE, push, filter, Econo-Coat	3	

5300-cfm Module

See Figure 8-1.

Item	Part	Description	Quantity	Note
—	343293	MODULE, Econo-Coat, 5300 cfm, 3 phase	1	
1	343297	• TOP PANEL, Econo-Coat	1	
2	343306	• PANEL, 27 in., wrapper	1	
3	-----	• SCREW, hex head, serrated, $\frac{3}{8}$ -16 UNC-2A x 1.0 in.	52	
4	-----	• NUT, hex, serrated, $\frac{3}{8}$ -16 UNC-2B	36	
5	343298	• PANEL, 39 in., wrapper	1	
6	-----	• FAN SECTION	1	
7	153129	• FLOW-THROUGH FILTER, 36 in., high efficiency	3	
8	147163	• CLOSED-END FILTER, 26 in., high efficiency	3	
9	1004667	• PLATE, push, filter, Econo-Coat	3	

6000-cfm Module

See Figure 8-1.

Item	Part	Description	Quantity	Note
—	343294	MODULE, Econo-Coat, 6000 cfm, 3 phase	1	
1	343297	• TOP PANEL, top, Econo-Coat	1	
2	343298	• PANEL, 39 in., wrapper	1	
3	-----	• SCREW, hex head, serrated, $\frac{3}{8}$ -16 UNC-2A x 1.0 in.	52	
4	-----	• NUT, hex, serrated, $\frac{3}{8}$ -16 UNC-2B	36	
5	343298	• PANEL, 39 in., wrapper	1	
6	-----	• FAN SECTION	1	
7	153129	• FLOW-THROUGH FILTER, 36 in., high efficiency	3	
8	153134	• CLOSED-END FILTER, 36 in., high efficiency	3	
9	1007096	• PLATE, push, filter, Econo-Coat, 6000 cfm	3	

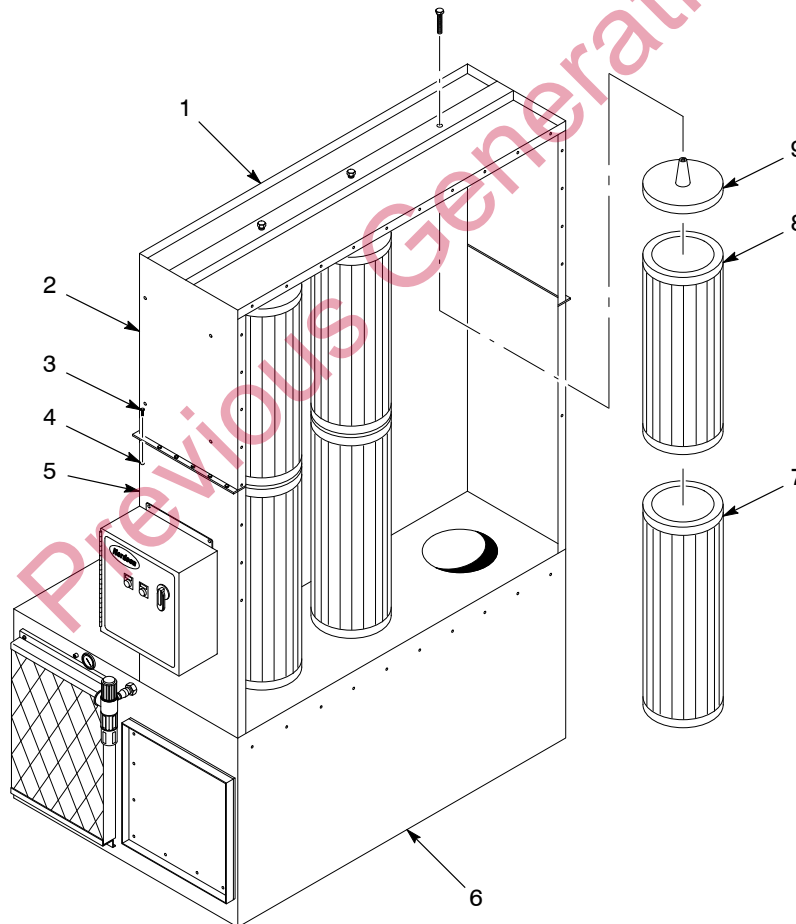

Figure 8-1 Collector Module Assembly

Fan Section

See Figure 8-2.

Item	Part	Description	Quantity	Note
—	-----	CABINET ASSEMBLY, Econo-Coat	1	
1	-----	• MOTOR ASSEMBLY	1	A
2	971778	• BULKHEAD UNION, 6-mm tubing	AR	
3	183988	• GAUGE, minihelic, 0–5.0 in. scale	1	
4	900742	• TUBING, polyurethane, 6-mm OD, blue	AR	
5	-----	• CLAMP, hose, worm drive	2	
6	-----	• FITTING, barbed, $\frac{3}{4}$ -in. hose x $\frac{3}{4}$ -in. NPT	1	
7	973077	• NIPPLE, steel, schedule 40, $\frac{1}{2}$, 3 in.	1	
8	-----	• COUPLING, pipe, class 150, $\frac{3}{4}$ x $\frac{1}{2}$ in.	1	
9	973096	• NIPPLE, steel, schedule 40, $\frac{3}{4}$, 3 in.	1	
10	176427	• REGULATOR with gauge and filter	1	
NS	179240	• • FILTER ELEMENT, replacement	1	
11	-----	• SCREW, hex head, serrated, $\frac{3}{8}$ -16 UNC-2A x 1.0 in.	AR	
12	176358	• CLAMP, final filter	AR	
13	101432	• FILTER, final, 500 series	AR	
14	343300	• PLATE, access, Econo-Coat	1	
15	-----	• GASKET, C-cell, neoprene with adhesive, 0.25 x 1.25 in.	AR	
16	-----	• CABINET, housing, Econo-Coat	1	
17	-----	• FITTING, barbed, swivel, $\frac{3}{4}$ -in. hose x $\frac{3}{4}$ -in. NPT	1	
18	-----	• NIPPLE, pipe, $\frac{3}{4}$ x $\frac{1}{2}$ -in. NPT	1	
19	972126	• ELBOW, male, 6-mm tube x $\frac{1}{8}$ -in. NPT	AR	
20	343301	• MANIFOLD, pulse, Econo-Coat	1	
21	174710	• VALVE, pulse, 1-in. NPT in, 1-in. NPT out	AR	
22	165726	• NOZZLE, cartridge pulse	AR	
23	343310	• CONE, aluminum inlet, size 16	1	
24	-----	• HOSE, $\frac{3}{4}$ x 2 ft, air line, 300 psi	1	B

NOTE A: Refer to *Motor Assembly* for parts breakdown.
 B: Contact your Nordson representative for the availability of this part.

AR: As Required
 NS: Not Shown

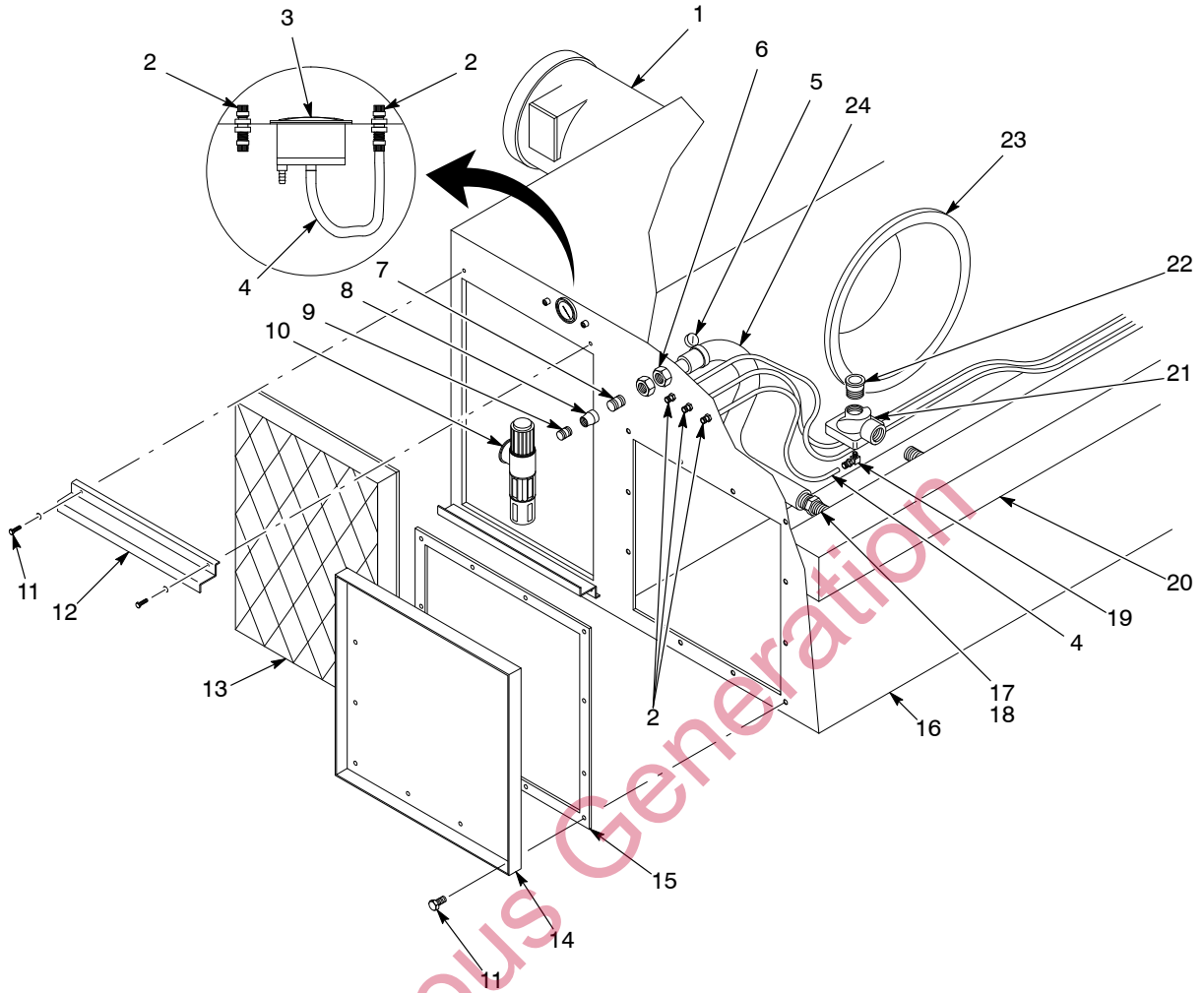

Figure 8-2 Fan Section

Motor and Fan Assembly

See Figure 8-3.

1000-cfm Motor and Fan Assembly

Item	Part	Description	Quantity	Note
—	-----	MOTOR and fan assembly, 1000 cfm	1	
1	-----	• MOTOR, 2 hp, C-face, 1-phase, 110 Volt	1	A
2	-----	• PLATE, motor, 1000 cfm	1	
3	-----	• FAN, wheel, aluminum, Econo-Coat, 1000 cfm	1	

NOTE A: For additional voltage or phase requirements, contact your Nordson Corporation service representative.
AR: As Required

2000-cfm Motor and Fan Assembly

Item	Part	Description	Quantity	Note
—	1006464	MOTOR and fan assembly, 2000 cfm	1	
1	1006465	• MOTOR, 3 hp, C-face, 3-phase, 208-230/460 Volt	1	A
2	1006468	• PLATE, motor, 2000 cfm	1	
3	1006467	• FAN, wheel, aluminum, Econo-Coat, 2000 cfm	1	

NOTE A: For additional voltage or phase requirements, contact your Nordson Corporation service representative.
AR: As Required

3400-cfm Motor and Fan Assembly

Item	Part	Description	Quantity	Note
—	1006466	MOTOR and fan assembly, 3400 cfm	1	
1	343309	• MOTOR, 5 hp, C-face, 3-phase, 208-230/460 Volt	1	A
2	1004629	• PLATE, motor, 3400 cfm	1	
3	343308	• FAN, wheel, Econo-Coat, 3400 cfm	1	

NOTE A: For additional voltage or phase requirements, contact your Nordson Corporation service representative.
AR: As Required

5300- and 6000-cfm Motor and Fan Assembly

Item	Part	Description	Quantity	Note
—	1004666	MOTOR and fan assembly, 5300 and 6000 cfm	1	
1	343312	• MOTOR, 10 hp, 3-phase, 208-230/460 Volt	1	A
2	1004712	• PLATE, motor, 5300 and 6000 cfm	1	
3	343311	• FAN, wheel, Econo-Coat, 5300 and 6000 cfm	1	

NOTE A: For additional voltage or phase requirements, contact your Nordson Corporation service representative.
AR: As Required

Motor and Fan Assembly (contd)

Common Motor and Fan Assembly Components

Item	Part	Description	Quantity	Note
4	-----	SCREW, hex head, serrated, 1/2-13 UNC-2A x 1.50 in.	4	
5	-----	CONDUIT, flexible	AR	
6	-----	CONNECTOR, straight, ST-50	1	
7	-----	REDUCER, electrical	1	
8	-----	RING, sealing	1	
9	-----	GASKET, C-cell, neoprene with adhesive, 0.25 x 1.25 in.	AR	

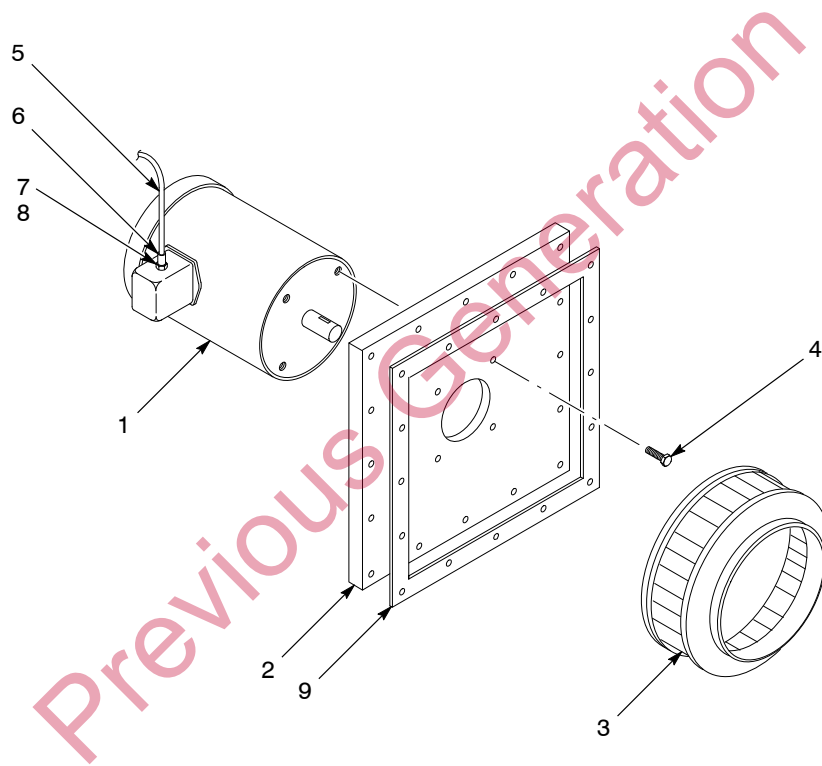

Figure 8-3 Motor and Fan Assembly

Single-Phase Control Panel

Single-Phase Control Panel Assemblies

Part	Description	Note
-----	1 phase, 2 hp, control panel, Econo-Coat	
1006543	1 phase, 3 hp, control panel, Econo-Coat	
1010141	1 phase, 5 hp, control panel, Econo-Coat	
1010142	1 phase, 10 hp, control panel, Econo-Coat	

Single-Phase Control Panel Components – 1001 Booth

See Figure 8-4.

NOTE: To order the parts listed in the following tables, contact your local distributor or the company listed in the Manufacturer column.

Item	Quantity	Description	Part Number	Manufacturer
—	1	Back panel	OEC14P12	OEC
—	1	Enclosure	RJ1412HPL	Stahlin
M111	1	Contact, IEC, 3-P, N-REV, 120 V	XTCE032C10A	Cutler-Hammer
M111	1	Auxiliary contact, 2 N.O.	XTCEXSCC11	Cutler-Hammer
OL111	1	Overload, IEC, 3-P, FXD HTR	XT0B032CC11	Cutler-Hammer
FU103	1	Fuse, D-E, T-D, J, 600 V	LPJ40SP	Bussmann
FU107	1	Fuse, T-D, J, 600 V	MDL3	Bussmann
FU103	1	Fuseblock	J60060-1CCR	Marathon
FU107	1	Fuseblock	354901GY	Littlefuse
—	1	Cycle Bypass Switch	HW1S2TF10	IDEC
—	1	Power On/Off Switch	HW1S2TF10	IDEC
PBL111	1	Pushbutton, illuminated, amber	HW1LM1F10QDA120	IDEC
PB111	1	Pushbutton, red, NC	HW1BM2F01R	IDEC
PB111	1	Nameplate, red	-----	OEC
PBL111	1	Nameplate, black	-----	OEC
TR113	1	Timer board	3RP1555-1AQ30	NCC
SOL1	1	Male connector	KQ2H06-01S	SMC
SOL1	1	Blowdown solenoid	RCA-3D2	SMC
PS111	1	Pressure switch	RFS4150	Cleveland
PS111	1	Breather vent	F28	Alwitco
—	2	Ground lug	FLC-4	Comec
—	1 ft	6 mm poly tubing	1J-242-10	SMC
—	8	Terminal blocks	6H38TSF	Marathon
—	1	End block	6H38-E-F	Marathon

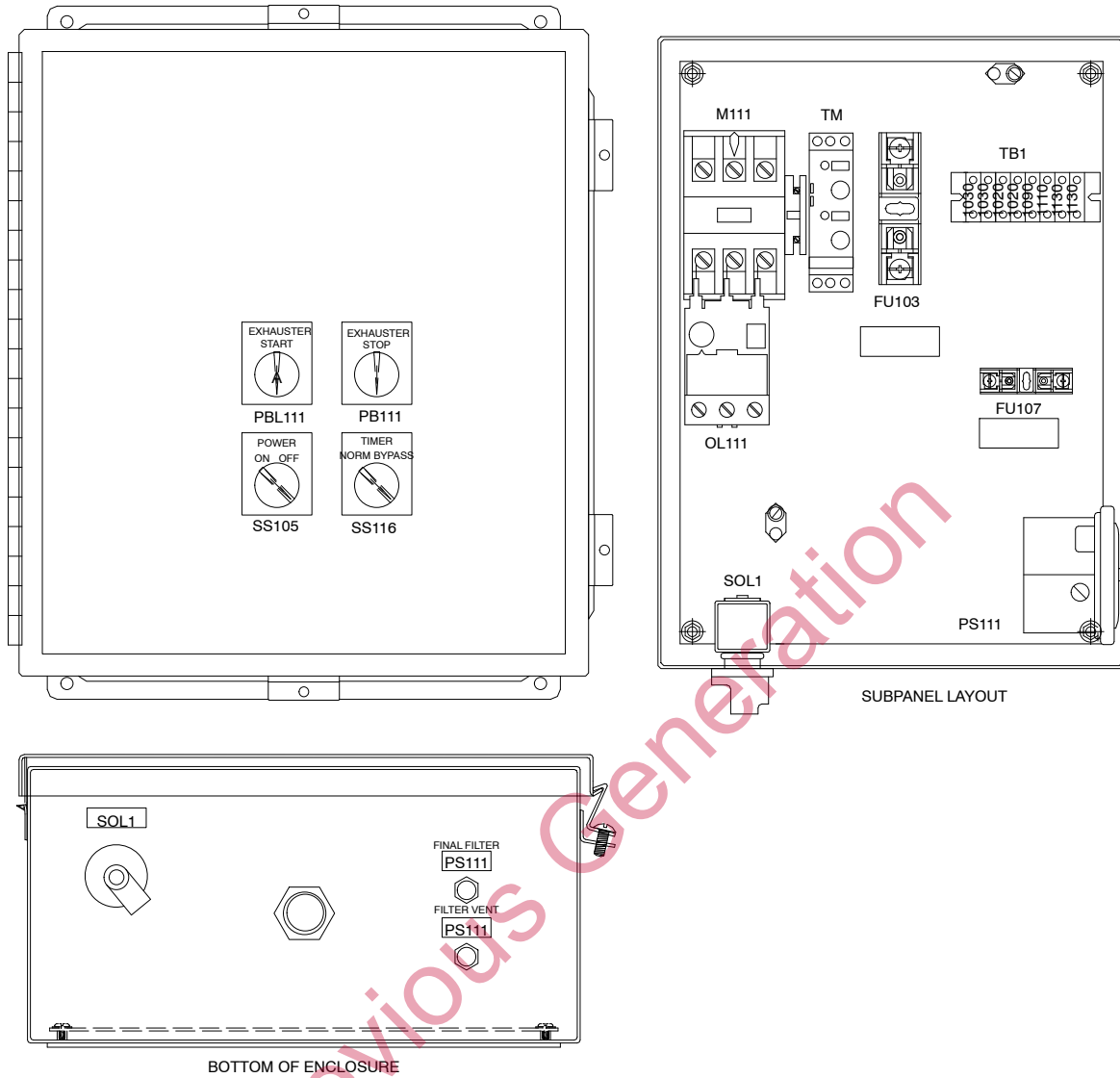

Figure 8-4 Single-Phase Control Panel – 1001 Booth (Typical)

Single-Phase Control Panel Components – 2001 and Larger Booths

See Figure 8-5.

NOTE: To order the parts listed in the following tables, contact your local distributor or the company listed in the Manufacturer column.

Item	Quantity	Description	Part Number	Manufacturer
—	1	Back panel	15X13	OEC
—	1	Enclosure with panel	SCE-1614CH	Saginaw
DISC101	1	Disconnect switch	Refer to <i>Disconnect</i>	ABB
DISC101	1	Disconnect handle	OHB65J5	ABB
DISC101	1	Shaft	OESA-ZS25	ABB
M111	1	Contact, IEC, 3-P, N-REV, 120 V	Refer to <i>Exhauster Motor</i>	Cutler-Hammer
M111	1	Auxiliary contact, 2 N.O.	C320KGT4	Cutler-Hammer
OL111	1	Overload, IEC, 3-P, FXD HTR	Refer to <i>Exhauster Motor</i>	Cutler-Hammer
FU103	1 or 2	Fuse, D-E, T-D, J, 600 V	Refer to <i>Exhauster Motor</i>	Busssmann
FU107	1	Fuse, T-D, 600 V	FNQ-10	Busssmann
FU103	1	Fuseblock	Refer to <i>Exhauster Motor</i>	Marathon
FU107	1 or 2	Fuseblock	BM6031PQ	Cutler-Hammer
PBL111	1	Pushbutton, illuminated, amber	E22TB9X8W	Cutler-Hammer
PBL111	AR	Lamp, incandescent, 120 V	28-2468-7	Cutler-Hammer
PB111	1	Pushbutton, red, NC	E22EB2B	Cutler-Hammer
PB111	1	Nameplate, red	-----	OEC
PBL111	1	Nameplate, black	-----	OEC
TR113	1	Timer board	DNC-T2003-B10	NCC
SOL1 SOL2 SOL3	3	Male connector	KQ2H06-01S	SMC
SOL1 SOL2 SOL3	3	Blowdown solenoid	RCA-3D2	Goyen
PS111	1	Pressure switch	1910-5	Dwyer
PS111	1	Bulkhead union	KQ2E06-00	SMC
PS111	1	Male elbow	KQ2L06-01S	SMC
PS111	1	Breather vent	F28	Alwitco
—	2	Ground lug	14-4L70	Comec
—	1 ft	6 mm poly tubing	TU0604-BU	SMC
TB1	6	Terminal blocks	6H38TSF	Marathon
TB1	1	End block	6H38-E-F	Marathon

Single-Phase Control Panel Components – 2001 and Larger Booths

(contd)

Disconnect

Item	115 Volt	200 Volt	208 Volt	230 Volt
DISC101 (3 hp)	OT60E3	OT60E3	OT60E3	OT32E3
DISC101 (5 hp)	OT100E3	OT60E3	OT60E3	OT45E3
DISC101 (10 hp)	—	—	OT100E3	OT100E3

3-hp Exhauster Motor

Item	115 Volt	200 Volt	208 Volt	230 Volt
M111	CE15GN3AB	CE15EN3AB	CE15EN3AB	CE15DN3AB
OL111	C316KNA3C	C316FNA3S	C316FNA3S	C316FNA3R
FU103	LPJ-60SP	LPJ-35SP	LPJ-35SP	LPJ-30SP
FU103	R6J60A1B	R6J60A2B	R6J60A2B	R6J30A2B

5-hp Exhauster Motor

Item	115 Volt	200 Volt	208 Volt	230 Volt
M111	CE15JN3AB	CE15GN3AB	CE15FN3AB	CE15FN3AB
OL111	C316KNA3E	C316KNA3C	C316FNA3T	C316FNA3T
FU103	LPJ-100SP	LPJ-60SP	LPJ-60SP	LPJ-50SP
FU103	6J100A1B	R6J60A2B	R6J60A2B	R6J60A2B

10-hp Exhauster Motor

Item	115 Volt	200 Volt	208 Volt	230 Volt
M111	—	—	CE15JN3AB	CE15JN3AB
OL111	—	—	C316KNA3E	C316KNA3D
FU103	—	—	LPJ-100SP	LPJ-90SP
FU103	—	—	6J100A1B	6J100A1B

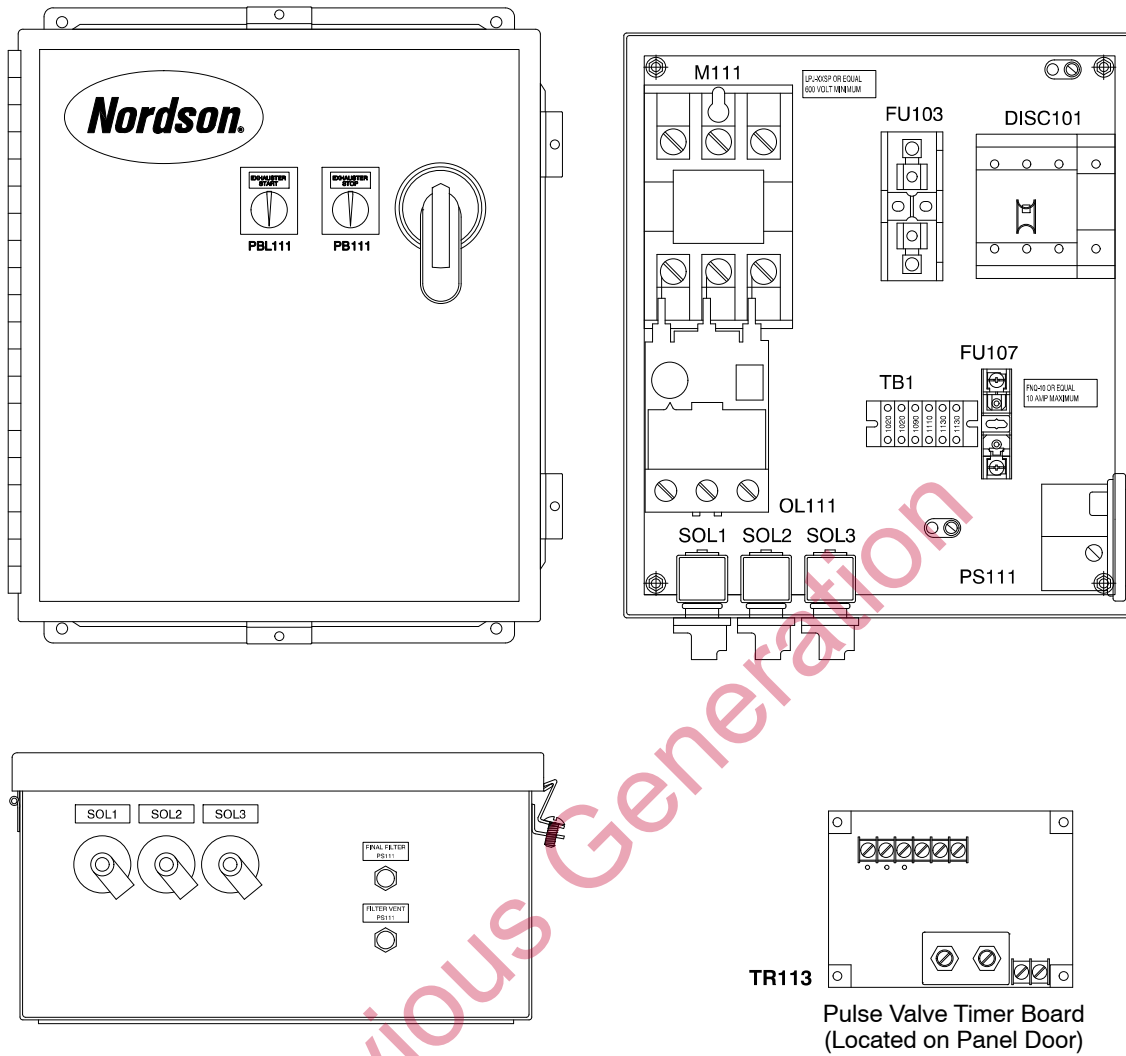

Figure 8-5 Single-Phase Control Panel – 2002 and Larger Booths

Three-Phase Control Panel

Three-Phase Control Panel Assemblies

Part	Description	Note
1004626	3 phase, 3 hp, control panel, Econo-Coat	
343321	3 phase, 5 hp, control panel, Econo-Coat	
343322	3 phase, 10 hp, control panel, Econo-Coat	

Three-Phase Control Panel Components

See Figure 8-6.

NOTE: To order the parts listed in the following tables, contact your local distributor or the company listed in the Manufacturer column.

Item	Quantity	Description	Part Number	Manufacturer
—	1	Back panel	15X13	OEC
—	1	Enclosure with panel	SCE-1614CH	Saginaw
DISC101	1	Disconnect switch	Refer to <i>Disconnect/Transformers</i>	ABB
DISC101	1	Disconnect handle	OHB65J5	ABB
DISC101	1	Shaft	OESA-ZS25	ABB
DISC101A	1	Auxiliary contact	OA1G10	ABB
M111	1	Contactor, IEC, 3-P, N-REV, 120 V	Refer to <i>Exhauster Motor</i>	Cutler-Hammer
M111	1	Auxiliary contact, 2 N.O.	C320KGT4	Cutler-Hammer
OL111	1	Overload, IEC, 3-P, FXD HTR	Refer to <i>Exhauster Motor</i>	Cutler-Hammer
FU103	3	Fuse, D-E, T-D, J, 600 V	Refer to <i>Exhauster Motor</i>	Busssmann
FU107	1	Fuse, T-D, 600 V	FNQ-10	Busssmann
FU103	1	Fuseblock	Refer to <i>Exhauster Motor</i>	Marathon
FU107	1	Fuseblock	BC6032PQ	Busssmann
PBL111	1	Pushbutton, illuminated, amber	E22TB9X8W	Cutler-Hammer
PBL111	AR	Lamp, incandescent, 120 V	28-2468-7	Cutler-Hammer
PB111	1	Pushbutton, red, NC	E22EB2B	Cutler-Hammer
PB111	1	Nameplate, red	-----	OEC
PBL111	1	Nameplate, black	-----	OEC
TR113	1	Timer board	DNC-T2003-B10	NCC
SOL1 SOL2 SOL3	3	Male connector	KQ2H06-01S	SMC
SOL1 SOL2 SOL3	3	Blowdown solenoid	RCA-3D2	Goyen
PS111	1	Pressure switch	1910-5	Dwyer
PS111	1	Bulkhead union	KQ2E06-00	SMC
PS111	2	Male elbow	KQ2L06-01S	SMC
PS111	1	Breather vent	F28	Alwitco
—	2	Ground lug	14-4L70	Comec
—	1 ft	6 mm poly tubing	1J-242-10	SMC
TB1	6	Terminal blocks	TU0604-BU	Marathon
TB1	1	End section	6H38-E-F	Marathon

Three-Phase Control Panel Components (contd)**Disconnect/Transformers**

Item	208 Volt	230 Volt	380 Volt	415 Volt	460 Volt	575 Volt
DISC101 (3 hp)	OT16E3	OT16E3	OT16E3	OT16E3	OT16E3	OT16E3
DISC101 (5 hp)	OT32E3	OT32E3	OT16E3	OT16E3	OT16E3	OT16E3
DISC101 (10 hp)	OT45E3	OT45E3	OT32E3	OT32E3	OT32E3	OT16E3

3-hp Exhauster Motor

Item	208 Volt	230 Volt	380 Volt	415 Volt	460 Volt	575 Volt
M111	CE15CN3AB	CE15CN3AB	CE15AN3AB	CE15AN3AB	CE15AN3AB	CE15AN3AB
OL111	C316FNA3Q	C316FNA3P	C316FNA3N	C316FNA3M	C316FNA3M	C316FNA3K
FU103	LPJ-20SP	LPJ-20SP	LPJ-12SP	LPJ-10SP	LPJ-10SP	LPJ-7SP
FU103	R6J30A3B	R6J30A3B	R6J30A3B	R6J30A3B	R6J30A3B	R6J30A3B

5-hp Exhauster Motor

Item	208 Volt	230 Volt	380 Volt	415 Volt	460 Volt	575 Volt
M111	CE15DN3AB	CE15DN3AB	CE15CN3AB	CE15BN3AB	CE15BN3AB	CE15AN3AB
OL111	C316FNA3R	C316FNA3R	C316FNA3Q	C316FNA3P	C316FNA3P	C316FNA3N
FU103	LPJ-35SP	LPJ-30SP	LPJ-20SP	LPJ-20SP	LPJ-15SP	LPJ-12SP
FU103	R6J60A3B	R6J30A3B	R6J30A3B	R6J30A3B	R6J30A3B	R6J30A3B

10-hp Exhauster Motor

Item	208 Volt	230 Volt	380 Volt	415 Volt	460 Volt	575 Volt
M111	CE15HN3AB	CE15FN3AB	CE15EN3AB	CE15DN3AB	CE15DN3AB	CE15CN3AB
OL111	C316KNA3C	C316FNA3T	C316FNA3S	C316FNA3R	C316FNA3R	C316FNA3Q
FU103	LPJ-60SP	LPJ-50SP	LPJ-35SP	LPJ-30SP	LPJ-25SP	LPJ-20SP
FU103	R6J60A3B	R6J60A3B	R6J60A3B	R6J30A3B	R6J30A3B	R6J30A3B

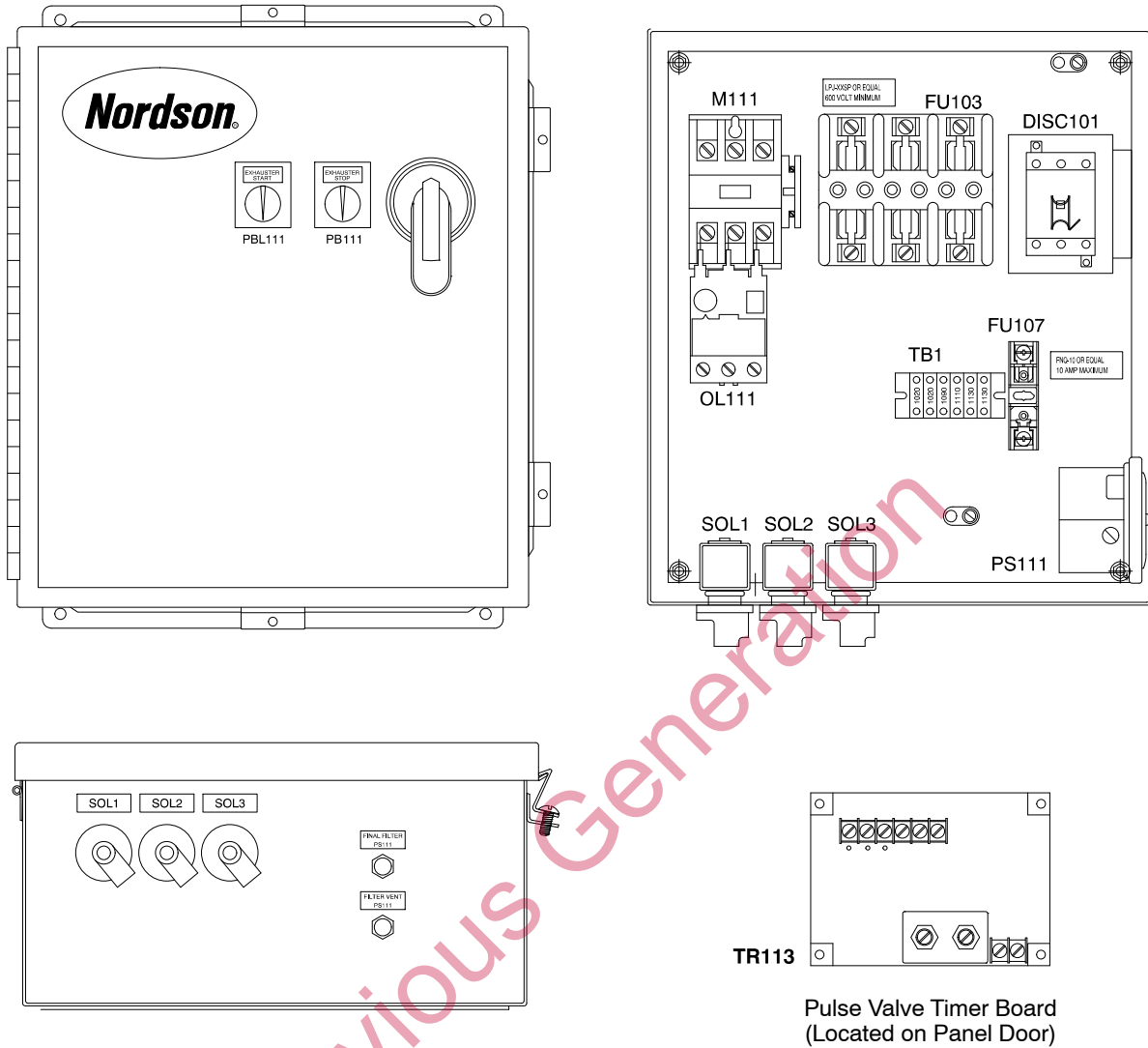

Figure 8-6 Three-Phase Control Panel

Wall Panels

Galvanized and Stainless Steel Wall Panels

Galvanized Part	Stainless Steel Part	Size, in.
179189	179166	30 x 108
179195	179172	30 x 120
1007084	1007085	36 x 60
1007086	1007087	42 x 60
1007042	1007043	6 x 60
179185	179162	6 x 96
1006362	1006363	6 x 120
1007044	1007045	12 x 27
179190	179167	12 x 60
1006357	1006358	12 x 96
1006360	1006361	12 x 108
179194	179171	12 x 120
1007046	1007047	15 x 60
1007072	1007073	15 x 72
179191	179168	18 x 60
179183	179160	18 x 84
1007048	1007049	24 x 30
179192	179169	24 x 60
179186	179163	24 x 96
179188	179165	24 x 108
1007070	1007071	30 x 30
1007074	1007075	30 x 36
1007076	1007077	30 x 42
1007078	1007079	30 x 48
1007080	1007081	30 x 54
179193	179170	30 x 60
1007082	1007083	30 x 66
1006470	1007095	30 x 72
179184	179161	30 x 84
179187	179164	30 x 96

Polypropylene Wall Panels

Part	Description
343314	SIDE PANEL, canopy, 60 x 60 in.
343315	BACK PANEL, canopy

Roof Panels

Galvanized and Stainless Steel Roof Panels

Galvanized Part	Stainless Steel Part	Size, in.
179196	179173	30 x 60
179197	179174	30 x 72
179198	179175	30 x 84
179199	179176	30 x 96
179200	179177	30 x 108
179201	179178	30 x 120

Polypropylene Roof Panels

Part	Description
343316	CANOPY PANEL roof, 60 x 63 in.
176245	ROOF PANEL, polypropylene, Versa-Coat, 28.5 x 123 in.
176244	ROOF PANEL, polypropylene, Versa-Coat, 28.5 x 63 in.

Brackets

Galvanized Part	Stainless Steel Part	Size, in.
340630	340629	30
179203	176322	48
179204	176323	60
179205	176324	72
179206	176325	84
1007298	1007299	96
1007320	1007321	102
1007322	1007323	108
1007324	1007325	114
1007326	1007327	120
1007328	1007329	126
1007330	1007331	132
1007332	1007333	138
1007334	1007335	144

Hinges

Part	Size, in.
1007343	24
1007345	30
1007347	36
1007349	42
1007351	48
1007353	54
1007355	60
1007357	66
1007360	72

Roof Supports

Batch Booth Roof Supports

Galvanized Part	Stainless Steel Part	Size, in.
179207	176316	108 x 84
179208	176317	144 x 120
179209	176318	144 x 96
179210	176319	180 x 96
179211	176320	168 x 108
179212	176321	120 x 120
333481	333482	144 x 108
333483	333484	96 x 120
333479	333480	96 x 168
1007098	1010971	108
1007096	1022604	120
1022607	1022608	144
1022611	1022610	168

6000-cfm Conveyor Booth Roof Support

Part	Description
174825	ROOF SUPPORT, universal, 36 x 23 x 8 in.

Previous Generation

Section 9

Specifications

Operating Environment

Econo-Coat booths perform best when operated in a proper environment and within certain design conditions. Talk to your Nordson representative if conditions within your plant do not meet these guidelines.

The powder coating system should be located in an area which maintains

- a temperature range of 21–27 °C (70–80 °F) and
- a humidity range of 45–55% relative humidity.

If temperature and humidity in the spray area exceed these ranges, it may be necessary to install air conditioning equipment.

Normal Design Conditions

Make sure that the following design considerations are met before operating your Econo-Coat booth.

Cross Drafts

Batch Booths: Air moving across the opening should not exceed 18.3 mpm (60 fpm).

Conveyor Booths: Air moving across the opening should not exceed 30.5 mpm (100 fpm).

Average Face Velocity

Average face velocity should be 24.4–30.5 mpm (80–100 fpm) through all openings in the booth enclosure.

Part Temperature

Part temperature should not exceed 48 °C (120 °F).

Powder

Nordson powder coating equipment is designed to operate with commercially available powders. The characteristics of a powder coating material can affect system operation. Powder coatings generally have an average particle size of 25–35 microns with no more than 10% of the total being less than 10 microns (fines). When the percentage of fines reaches 10% of the total, blinding or plugging of the cartridge filter media can occur.

Cartridge Filters

Each collector module uses either two or six cartridge filters. Cartridge filters are considered to be a wear item in a powder coating system. The life expectancy of a cartridge filter is dependent on many variables, including type of powder used; particle size distribution; humidity and temperature in the spray area; number of hours in operation; dew point and cleanliness of the system compressed air supply; frequency of cartridge cleaning; and total pulse air pressure.

Compressed Air

The compressed air volume requirement for the batch booth is 5 cfm @ 7 bar (100 psi).

The following customer-supplied components are needed to achieve the necessary compressed air requirements.

Air supply line (customer-supplied): The air supply line to the booth should be a minimum of 12.7 mm (0.5 in.) ID.

Desiccant-type air dryer (customer-supplied): The dedicated refrigerated or regenerative desiccant-type air dryer must be capable of a maximum pressure dewpoint of 3 °C (38 °F) @ 7 bar (100 psi).

Shutoff valve (customer-supplied): Use a shutoff valve with lockout capability ahead of any of the system devices.

Air regulator: Compressed air must be regulated to 4–7 bar (60–100 psi).

Air filter: Use a 0.3-micron coalescent-type compressed air filter to prevent oil and water from contaminating the powder supply and damaging the cartridge filters.

Workpiece Clearance

The clearances around workpieces inside of the booth should be as follows:

- Top: At least 0.6 m (2 ft); more if the top of the workpiece will also be coated
- Sides:
- 0.6 m (2 ft) if operator sprays from front of booth or operator opening;
 - 1.2 m (4 ft) if operator must enter a batch booth to coat other surfaces

Electrical Service

Use a fused disconnect switch for the primary electrical service to the booth. Use the following charts to calculate service requirements at the booth.

NOTE: All phases of installation must comply with all federal, state, and local codes. All work that is located in Class 2, Divisions 1 and 2 hazardous locations must comply with NFPA Code 33, Spray Application 1995 and NFPA Code 70, especially Articles 500, 502, and 516, latest editions.

Single-Phase Control Panel

Use the following chart to determine amperage requirements for a module with a single-phase control panel.

EC1001 Booth

120V, single phase, 60 Hz, 30 amp

EC2001 and Larger Booths

NOTE: Average requirements include 10 amp allowance for motor control and spray related devices.

hp	115 Volt	200 Volt	208 Volt	230 Volt
3	44.0	29.8	28.7	27.0
5	66.0	42.4	40.8	38.0
10	—	—	65.0	60.0

Three-Phase Control Panel

Use the following chart to determine amperage requirements for a module with a three-phase control panel.

NOTE: A 120 Vac, 10 amp, single-phase voltage supply is required for motor control and spray related device power.

hp	208 Volt	230 Volt	380 Volt	415 Volt	460 Volt	575 Volt
3	10.6	9.6	6.7	5.5	4.8	3.9
5	16.7	15.2	10.6	8.8	7.6	6.1
10	30.8	28.0	19.6	16.1	14.0	11.0

Previous Generation