

Cup Gun Kit for Tribomatic® 500 Manual Powder Spray Gun



WARNING: Allow only qualified personnel to perform the following tasks. Follow the safety instructions in this document and all other related documentation.

1. Introduction

The cup gun kit attaches to a Nordson Tribomatic 500 manual powder spray gun. The kit is used for testing new powder coatings or for coating a few small parts with a powder coating different than that in your full-sized feed hoppers.

2. Installation

See Figure 1.

1. Clean the gun (3) according the instructions in the gun manual. Shut off the gun control unit.
2. Disconnect the diffuser air tubing (8) from the diffuser (4).
3. Disconnect the powder feed hose (5) from the diffuser.
4. Remove the diffuser from the gun.
5. Install the cup gun housing (2) into the gun, in place of the diffuser.
6. Connect the diffuser air tubing to the elbow fitting (1).
7. Disconnect the flow-rate air tubing (7) from the powder pump (6). Connect the tubing to the elbow fitting (9).

Installation (contd.)

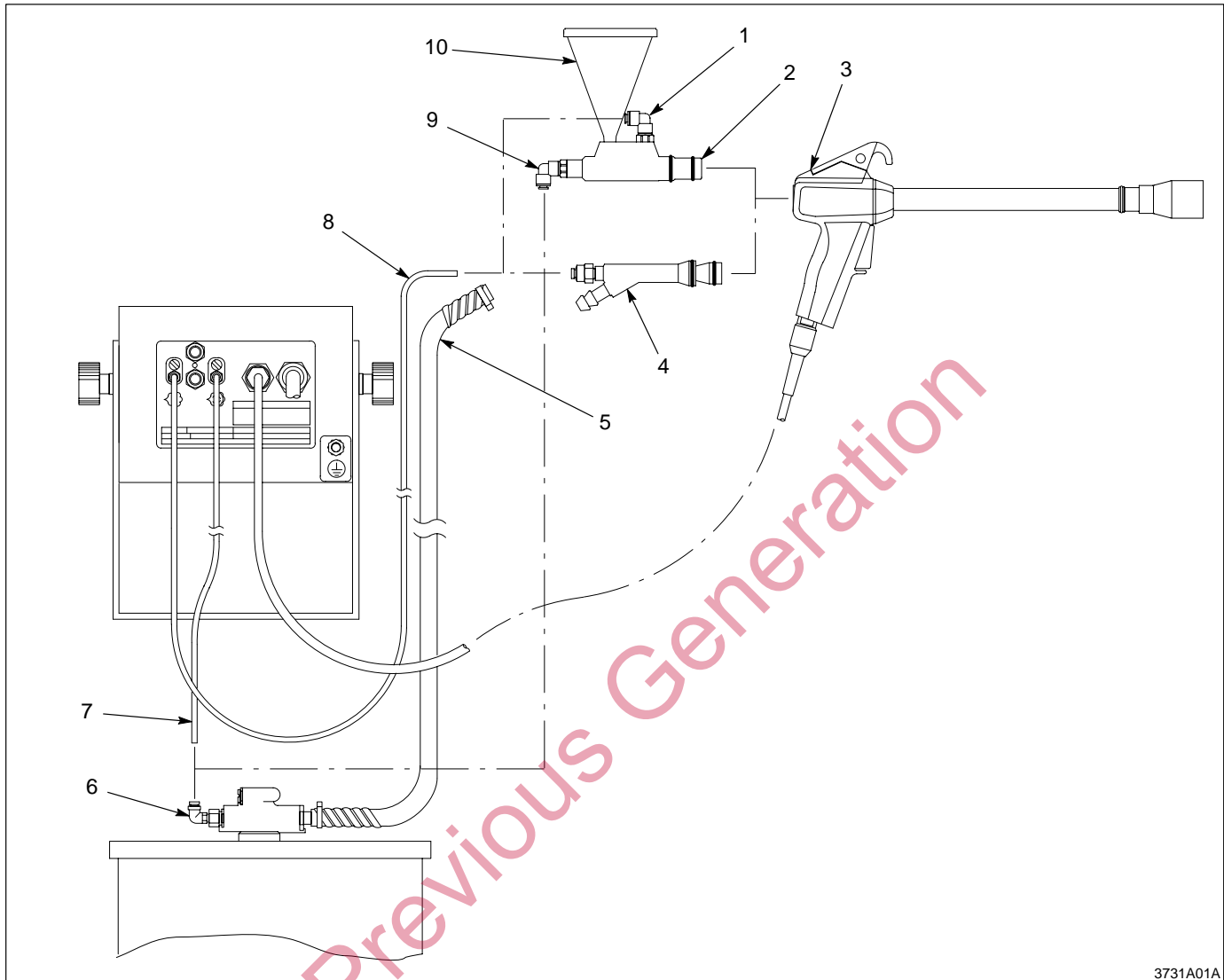

3731A01A

Fig. 1 Installing the cup gun kit on the spray gun

- | | | |
|---------------------------------|-------------------------|----------------------------------|
| 1. Elbow fitting (diffuser air) | 5. Powder feed hose | 8. Diffuser air tubing |
| 2. Cup gun housing | 6. Powder pump | 9. Elbow fitting (flow-rate air) |
| 3. Gun | 7. Flow-rate air tubing | 10. Funnel and lid |
| 4. Diffuser | | |

3. Operation

1. See Figure 1. Remove the lid and fill the funnel (10) with powder. Replace the lid.
2. Turn the control unit on and adjust the atomizing air pressure to 1.7 bar (25 psi). Set the flow-rate air pressure to zero.
3. Trigger the gun and slowly increase the flow-rate air pressure until you obtain the desired flow rate and spray pattern.

NOTE: Pressure settings will vary depending on powder type and spraying conditions.

4. Maintenance



CAUTION: When cleaning a powder system component with compressed air, make sure powder does not get blown back through air tubing into pressure regulators, gauges, or other control devices. Either disconnect the air tubing at the component or set the air pressure in the tubing higher than the cleaning air pressure.

Light Cleaning

1. See Figure 2. Empty the funnel (2) and set the diffuser air pressure to 3.4 bar (50 psi).
2. Remove the flow-rate air fitting (6) and venturi nozzle (4) as one piece. Blow out the cup gun housing with low-pressure compressed air.

Heavy Cleaning

1. See Figure 2. Perform the light cleaning procedure.
2. Disconnect the diffuser and flow-rate air air tubing from the elbow fittings (6).
3. Remove the cup gun housing (9) from the gun.
4. Remove the venturi throat (7) and funnel (2) from the cup gun body.
5. Clean the venturi nozzle and throat, housing, and funnel with low-pressure compressed air. Wipe all exposed surfaces with a clean, lint-free cloth.
6. Inspect all parts for wear or damage, especially the venturi throat. Replace any worn or damaged parts. Use only genuine Nordson replacement parts.

5. Parts

See Figure 2.

Item	Part	Description	Quantity	Note
—	306 162	Kit, cup gun, Tribomatic 500, packaged	1	
1	183 453	• Lid, funnel, cup gun	1	A
2	183 451	• Funnel, molded, cup gun	1	A
3	940 137	• O-ring, silicone, 0.437 x 0.562 x 0.063 in.	1	
4	183 462	• Nozzle, venturi, w/O-rings	1	
5	940 126	• • O-ring, silicone, 0.375 x 0.500 x 0.063 in.	2	
6	183 456	• Fitting, swivel, elbow, 6 mm tube x 1/8 in. BSPT	2	
7	225 547	• Throat, 0.188 in. diameter, Tivar, w/O-rings	1	
8	940 126	• • O-ring, silicone, 0.375 x 0.500 x 0.063 in.	2	
9	305 796	• Housing, cup gun, Tribomatic 500	1	
10	941 153	• O-ring, silicone, 0.688 x 0.875 x 0.094 in.	1	
11	941 162	• O-ring, silicone, 0.750 x 0.937 x 0.094 in.	1	

NOTE A: Included in the Funnel Kit (with lid and cap), part 183 464.

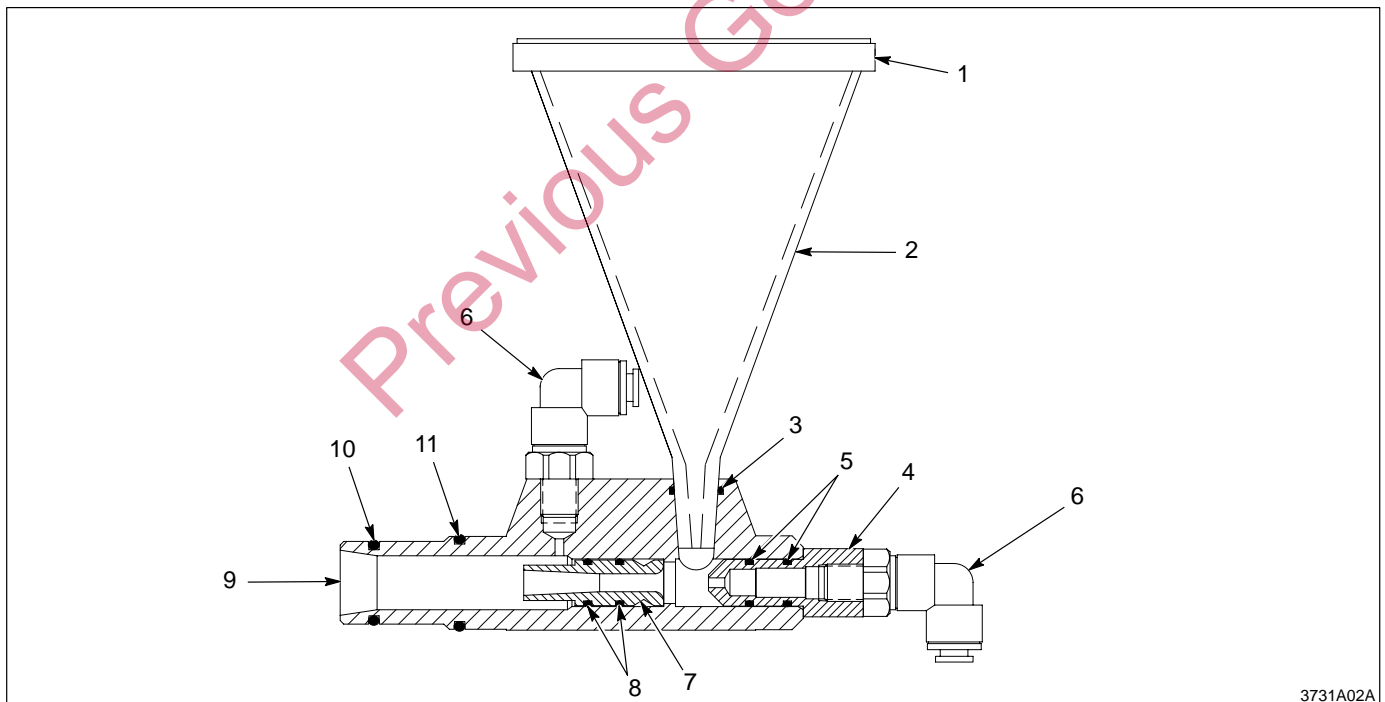

3731A02A

Fig. 2 Cup gun kit parts

Nordson, the Nordson logo, and Tribomatic are registered trademarks of Nordson Corporation.

Tivar is a registered trademark of Menasha Corporation.