

Tribomatic® Wand

Customer Product Manual
Part 303 820B

For parts and technical support, call the Industrial Coating Systems Customer Support Center at (800) 433-9319 or contact your local Nordson representative.

This document is subject to change without notice.
Check <http://emanuals.nordson.com> for the latest version.



Nordson Corporation welcomes requests for information, comments and inquiries about its products.

Address all correspondence to

Nordson Corporation
555 Jackson Street
Amherst, OH 44001

Notice

This is a Nordson Corporation publication which is protected by copyright. Original copyright date 1998. No part of this document may be photocopied, reproduced, or translated to another language without the prior written consent of Nordson Corporation. The information contained in this publication is subject to change without notice.

Trademarks

100 Plus, Blue Box, ChromaFlex, CleanSleeve, CleanSpray, Control Coat, Cross-Cut, Easy Coat, Econo-Coat, Excel 2000, Flow Sentry, Isocoil, Isocore, Iso-Flo, Nordson, the Nordson logo, PRX, Pro-Flo, RBX, Ready-Coat, Rhino, Select Coat, Select Cure, Shur-Lok, Smart Spray, System Sentry, Thread Coat, Tribomatic, and Versa-Spray are registered trademarks of Nordson Corporation.

CPX, CanWorks, Excel 2000, PowderGrid, Pulse Spray, SCF, Versa-Coat, Versa Screen, Package of Values, and Swirl Coat are trademarks of Nordson Corporation.

Viton is a registered trademark of E.I. DuPont de Nemours & Co.

Table of Contents

1. Safety	1
Qualified Personnel	1
Unintended Use	1
Ratings and Approvals	2
Personal Safety	2
Fire Safety	3
Action in the Event of a Malfunction	3
2. Description	4
Gun Operation	4
Specifications	5
3. Installation	6
Manual Guns	6
Automatic Guns	8
4. Operation	10
Break-In Period	10
Settings	11
Microampere Display	11
Daily Operation	11
5. Maintenance	12
6. Troubleshooting	13
7. Repair	15
8. Parts	17
Using the Illustrated Parts List	17
PTFE Automatic Spray Gun	18
Nylon Automatic Spray Gun	20
PTFE Manual Spray Gun	22
Nylon Manual Spray Gun	24

Service Kits List	26
All Gun Versions	26
Gun Body Kits	26
PTFE Gun Kits	26
Nylon Gun Kits	26
Accessories	27
Deflectors	27
Pattern Adjuster Sleeves	28
Slotted Nozzles	29
Extensions	29
Guide	30

Previous Generation

Tribomatic Wand

1. Safety

Read and follow these safety instructions. Task-and equipment-specific warnings, cautions, and instructions are included in equipment documentation where appropriate.

Make sure all equipment documentation, including these instructions, is accessible to all persons operating or servicing equipment.

Qualified Personnel

Equipment owners are responsible for making sure that Nordson equipment is installed, operated, and serviced by qualified personnel. Qualified personnel are those employee or contractors who are trained to safely perform their assigned tasks. They are familiar with all relevant safety rules and regulations and are physically capable of performing their assigned tasks.

Unintended Use

Use of Nordson equipment in ways other than those described in the documentation supplied with the equipment may result in injury to persons or damage to property.

Some examples of unintended use of equipment include

- using incompatible materials
- making unauthorized modifications
- using incompatible or damaged parts
- using unapproved auxiliary equipment
- operating the equipment in excess of its maximum ratings

Ratings and Approvals

Make sure all equipment is rated and approved for the environment in which it is used. Any approvals obtained for Nordson equipment will be voided if instructions for installation, operation, and service are not followed.

Personal Safety

To prevent injury follow these instructions.

- Do not operate or service equipment unless you are qualified.
- Do not operate equipment unless safety guards, doors, or covers are intact and automatic interlocks are operating properly. Do not bypass or disarm any safety devices.
- Keep clear of moving equipment. Before adjusting or servicing any moving equipment, shut off the power supply and wait until it comes to a complete stop. Lock out power and secure the equipment to prevent unexpected movement.
- Shut off and relieve (bleed off) air pressure before adjusting or servicing pneumatic equipment. Disconnect, lock out, and tag switches before servicing electrical equipment.
- While operating manual electrostatic spray guns, make sure you are grounded. Wear electrically conductive gloves or a grounding strap connected to the gun handle or other true earth ground. Do not wear or carry metallic objects such as jewelry or tools.
- If you receive even a slight electrical shock, shut down all electrical or electrostatic equipment immediately. Do not restart the equipment until the problem has been identified and corrected.
- Obtain and read Material Safety Data Sheets (MSDS) for all materials used. Follow the manufacturer's instructions for safe handling and use of materials, and use recommended personal protection devices.
- To prevent injury, be aware of less-obvious dangers in the workplace that often cannot be completely eliminated, such as hot surfaces, sharp edges, energized electrical circuits, and moving parts that cannot be enclosed or otherwise guarded for practical reasons.

Fire Safety

To avoid a fire or explosion, follow these instructions.

- Do not smoke, weld, grind, or use open flames where flammable materials are being used or stored.
- Provide adequate ventilation to prevent dangerous concentrations of volatile materials or toxic fumes. Maintain air flows at or above the levels specified in equipment documentation.
- Do not disconnect live electrical circuits while operating or cleaning powder coating systems. Shut off power at a disconnect switch first.
- Shut off electrostatic power and ground the charging system before adjusting, cleaning, or repairing electrostatic equipment. Test and maintain electrostatic equipment according to instructions. Use only original equipment replacement parts. Do not use parts from other manufacturers.
- Ground all conductive equipment in the spray area. Check equipment and workpiece grounding devices regularly. Resistance to ground must not exceed one megohm.
- Shut down all equipment immediately if you notice static sparking or arcing. Do not restart the equipment until the cause has been identified and corrected.
- If a fire starts in a spray booth, immediately shut off the spray system and exhaust fans.
- Know where emergency stop buttons, shutoff valves, and fire extinguishers are located.

Action in the Event of a Malfunction

If a piece of equipment malfunctions, shut it off immediately and perform the following steps:

- Disconnect and lock out electrical power. Close pneumatic shutoff valves and relieve pressures.
- Identify the reason for the malfunction and correct it before restarting the equipment.

2. Description

Tribomatic Wands are manual and automatic tribo-charging powder spray guns used to coat hard-to-reach interiors of tubes, pipes, and other parts and assemblies. The automatic gun can also be used in powder coating booths on conveyORIZED production systems to coat a wide variety of parts coating booths on conveyORIZED production systems. The guns are available with PTFE or nylon charge sleeves. PTFE is used with most organic powders, nylon is used primarily with PTFE powders.

A Nordson modular powder pump and Tribomatic II control unit are required for each gun in a system. Manual guns use three-gauge Tribomatic II control units. Automatic guns use two-gauge Tribomatic II control units. Manual guns ship with ground and control cables, while automatic guns require only a customer-supplied ground cable.

A nozzle with 19- and 34-mm conical deflectors for narrow and wide spray patterns are shipped with the wands. Accessories include deflectors in narrower and wider widths, pattern adjuster sleeves, slotted nozzles, and extensions for manual guns.

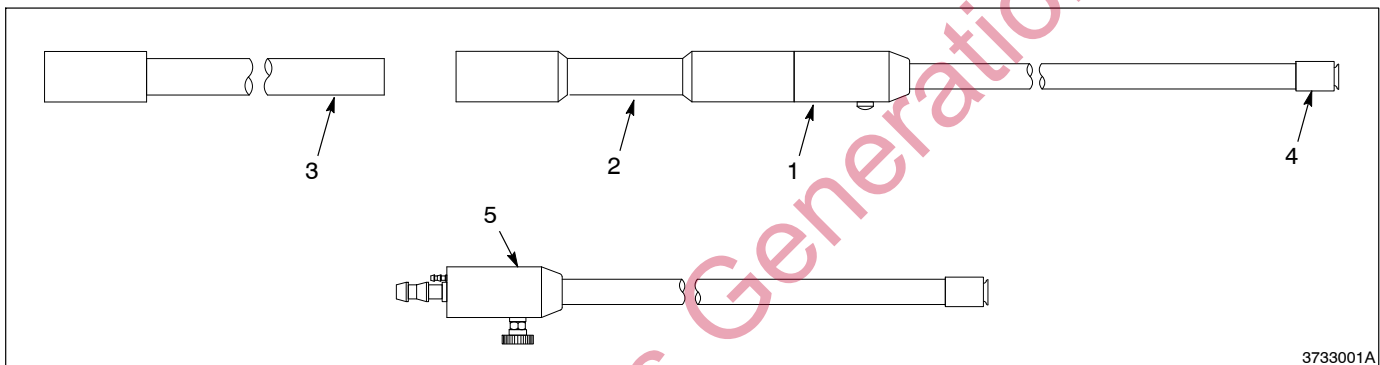

Fig. 1 Manual and Automatic Guns

- 1. Manual gun
- 2. Handle
- 3. Extension
- 4. Nozzle
- 5. Automatic gun

Gun Operation

See Figure 2 for the major gun components. A powder pump operated by compressed air pumps the powder out of a feed hopper. The powder is conveyed by the air flow through a powder feed hose (12) into the gun. Diffuser air flows through passages (3) in the gun body (4) and inlet diffuser (6) into the powder. Diffuser air breaks up any powder clumps and evenly suspends the powder particles in the air flow.

As the powder and air mixture flows between the inner charge sleeve (7) and outer charge sleeve (8), the powder particles collide with the charge sleeve walls and receive an electrostatic charge. The sleeves receive an opposite charge that is grounded through the support tube (5), ground stud (11), ground cable, and control unit. The control unit displays the grounded charge in microamperes of current. The higher the current shown on the display, the higher the charge received by the powder.

NOTE: The strength of the charge the powder receives will vary depending on many factors, including powder type and the velocity of the powder as it flows through the charge sleeves.

The deflector (10) and the nozzle (9) control the spray pattern shape. Changing the deflector or nozzle changes the size of the spray pattern. Pattern adjuster sleeves can be installed in place of the standard nozzles. These can be moved toward or away from the deflector to control the pattern shape.

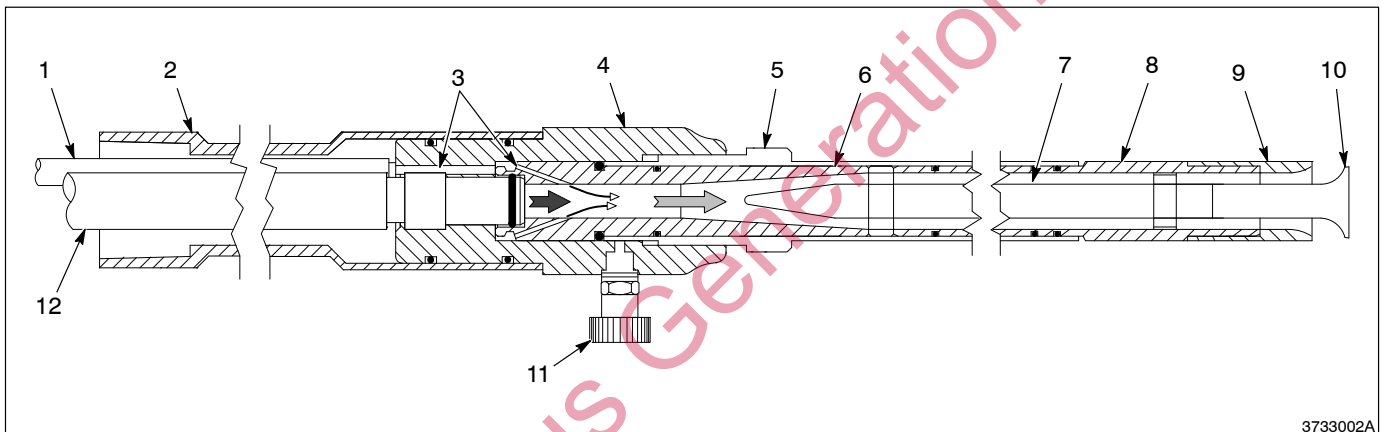

3733002A

Fig. 2 Simplified Cutaway View of Tribomatic Wand

- | | | |
|-------------------------|------------------------|------------------------|
| 1. Diffuser air tubing | 5. Bore housing tube | 9. Nozzle |
| 2. Handle | 6. Inlet diffuser | 10. Deflector |
| 3. Diffuser air passage | 7. Inner charge sleeve | 11. Ground stud |
| 4. Gun body | 8. Outer charge sleeve | 12. Powder feed tubing |

Specifications

Length and weight are given for standard guns. Adding accessories will change these measurements.

Length:	914 mm (36 in.)
Weight:	0.5 kg (1.1 lbs) (without cable)
Capacity:	4.5–6.8 kg (10–15 lbs) per hour

3. Installation



WARNING: Allow only qualified personnel to perform the following tasks. Observe and follow the safety instructions in this document and all other related documentation.



WARNING: Ground all electrically conductive equipment in the spray area. Ungrounded equipment can store an electrostatic charge that can give personnel a severe shock or arc and cause a fire or explosion.

Manual Guns

See Figure 3 for manual gun installation.

1. Connect black 6-mm air tubing (11) to the flow-rate air fitting on the control unit (5) and the elbow fitting on the powder pump (10).
2. Connect blue 6-mm air tubing (8) to the diffuser air fitting on the control unit. Install the tubing through the extensions (3) (if used) and handle (2). Connect the tubing to the small barbed connector on the manual gun body (1).
3. Connect 9-mm ($3/8$ -in.) ID powder feed hose (9) (use 13-mm ($1/2$ -in.) feed hose for large parts) to the barbed fitting on the powder pump. Install the feed hose through the extensions (if used) and handle. Connect the feed hose to the large barbed fitting on the gun body.

NOTE: Keep the powder feed hose as short as possible. The hose should not be longer than 12 m (39 ft) if using $1/2$ -in. ID hose. Longer lengths may cause uneven powder flows.

4. Route the ground cable (4) through the extensions (if used), through the handle and out the slot in the forward end of the handle. Connect the ground cable (4) to the ground stud on the gun body. Plug the ground cable into the connector on the control cable (7).
5. Install the end of the handle with the ground cable slot in it onto the gun body. Connect the extensions (if used) to the handle.
6. Connect the control cable to the GUN CONNECT receptacle on the back of the control unit.
7. Connect the control unit ground clamp (6) to a true earth ground.
8. Install spiral-cut plastic tubing around the powder feed hose at the pump connector. Secure the spiral-cut tubing with clamps. This will prevent the hose from kinking and blocking the flow of powder.

NOTE: To make the powder feed hose, air tubing, and control cable easy to handle, you can also bundle them together with short lengths of spiral-cut tubing.

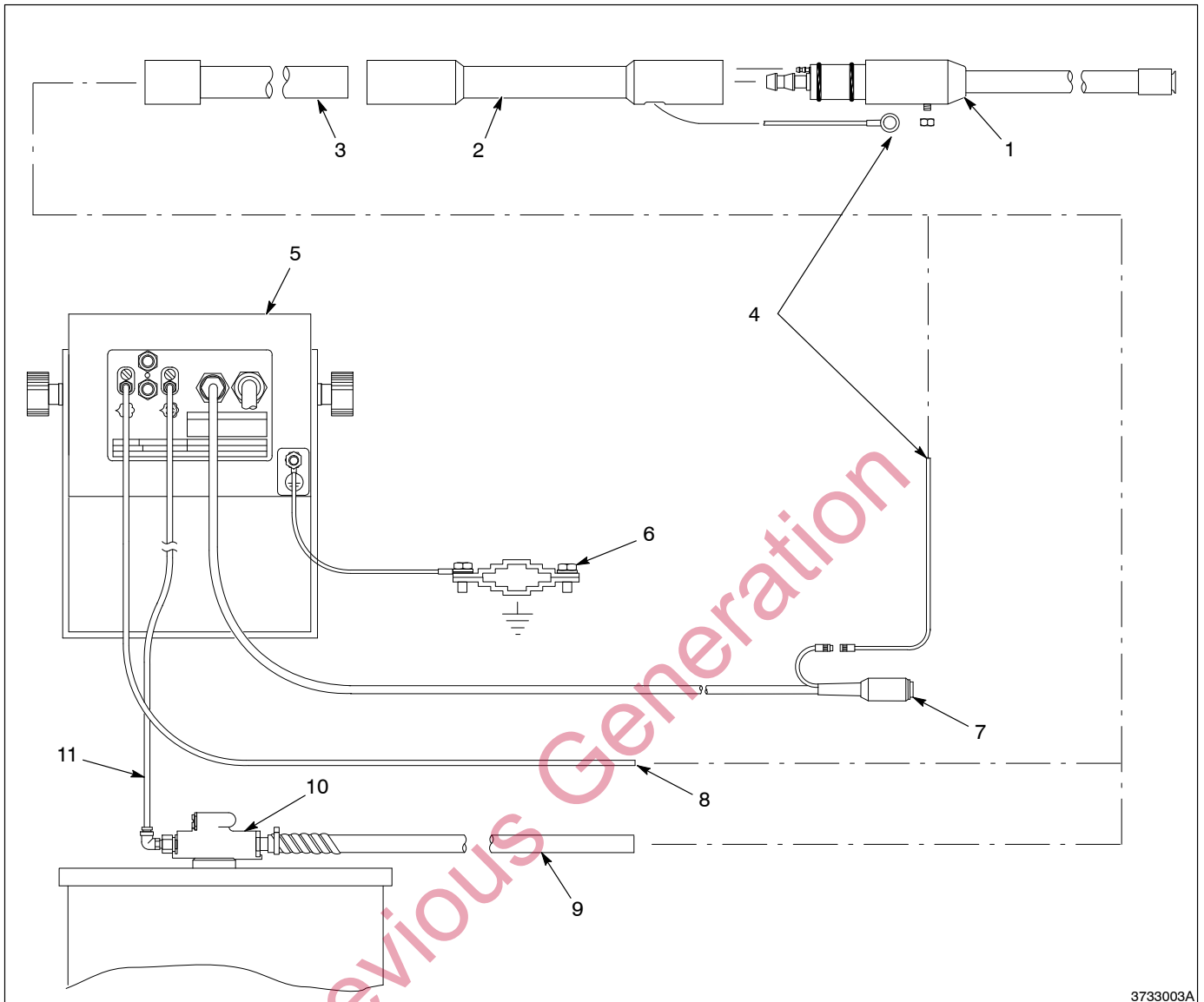

3733003A

Fig. 3 Installing a Manual Gun

- | | | |
|--------------------------|-------------------------|---------------------------|
| 1. Manual gun body | 5. Control unit | 9. Powder feed hose |
| 2. Handle | 6. Ground clamp | 10. Powder pump |
| 3. Extensions (optional) | 7. Control cable | 11. Black 6-mm air tubing |
| 4. Ground cable | 8. Blue 6-mm air tubing | |

Automatic Guns

See Figure 4 for automatic gun installation.

1. Connect black 6-mm air tubing (8) to the flow-rate air fitting on the control unit (5) and the elbow fitting on the powder pump (7).
2. Connect blue 6-mm air tubing (4) to the diffuser air fitting on the control unit. Connect the tubing to the small barbed connector on the automatic gun body (1).
3. Connect 9-mm ($3/8$ -in.) ID powder feed hose (6) (use 13-mm ($1/2$ -in.) feed hose for large parts) to the barbed fitting on the powder pump. Connect the hose to the large barbed fitting on the gun body.

NOTE: Keep the powder feed hose as short as possible. The hose should not be longer than 12 m (39 ft) if using $1/2$ -in. ID hose. Longer lengths may cause uneven powder flows.

4. Make a ground cable. Use 18 gauge wire and terminate both ends with 22-18 ring-tong terminals. Connect the ground cable (2) to the ground stud on the gun body and the ground stud labeled GUN CONNECT on the back of the control unit.
5. Connect the control unit ground clamp (3) to a true earth ground.
6. Install spiral-cut plastic tubing around the powder feed hose at the pump connector, and around the hose and the diffuser air tubing at the gun body. Secure the spiral-cut tubing with clamps. This will prevent the hose and tubing from kinking and blocking the flow of powder and air.

NOTE: To make the powder feed hose, air tubing, and ground cable easy to handle, you can also bundle them together with short lengths of spiral-cut tubing.

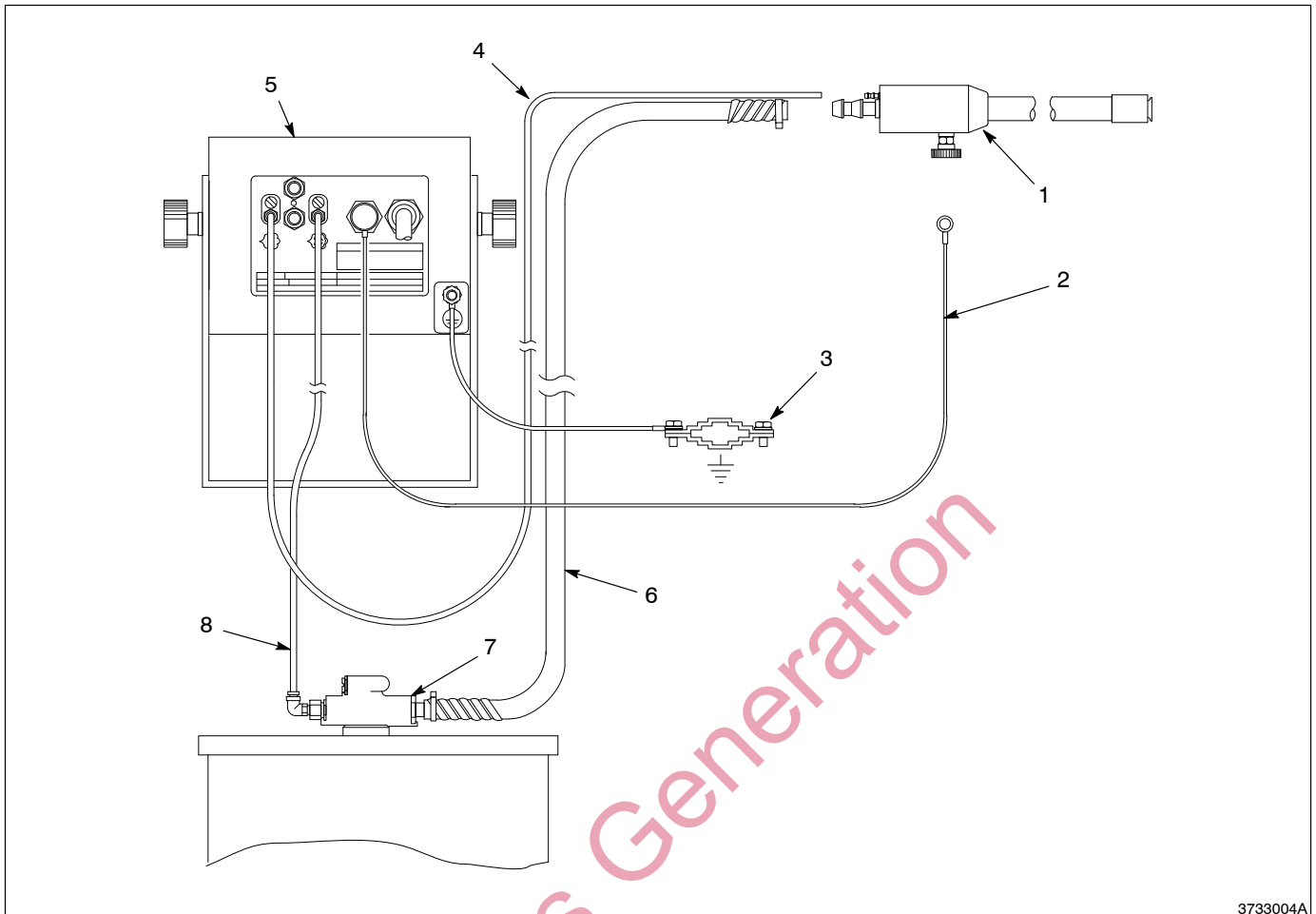

3733004A

Fig. 4 Installing an Automatic Gun

- | | | |
|-----------------------|-------------------------|--------------------------|
| 1. Automatic gun body | 4. Blue 6-mm air tubing | 7. Powder pump |
| 2. Ground cable | 5. Control unit | 8. Black 6-mm air tubing |
| 3. Ground clamp | 6. Powder feed hose | |

4. Operation



WARNING: Allow only qualified personnel to perform the following tasks. Observe and follow the safety instructions in this document and all other related documentation.



WARNING: Manual gun operators must be grounded. Use conductive gloves or a grounding strap. Do not carry metallic objects in pockets or wear jewelry. Failure to observe this warning may result in a severe shock.

Break-In Period

Break in new guns before using them for production. The break-in process allows the electrostatic charge generated in the sleeves time to establish a path to ground. Powder charging will improve as the ground path becomes firmly established.

To break in a new gun, spray powder for 10 minutes, using the air pressure settings given in this section. Put down the gun and do not use it for $\frac{1}{2}$ to 1 hour. This will give the electrostatic charge generated in the gun time to find its way through the internal components to the ground stud. You may hear a slight popping sound from the gun as this happens.

When you disassemble the gun for cleaning or repairs, you may see small black marks (carbon tracking or tiny pinholes) on the outer charge sleeve, where the outer charge sleeve contacts the bore housing tube. This is normal, and will not affect gun operation.

Previous Generation

Settings

Set flow-rate and diffuser air pressures at the control unit. Refer to your control unit manual for the location of the regulators.

Air pressure controls powder velocity, flow rate, atomization, and charging. To start, set the regulators as follows:

Flow-rate air	2 bar (30 psi)
Diffuser air	1 bar (15 psi)

Adjust these pressures to obtain the desired results as follows:

- Increase flow-rate air pressure to increase film build; decrease pressure to decrease film build.
- Increase diffuser air pressure to increase electrostatic charging. Decrease diffuser pressure to decrease charging.

Microampere Display

When using automatic guns, you should see 1.4–4 microamperes of current output displayed at the control unit. Current output varies depending on the powder velocity, type of powder, and compressed air moisture content. The higher the output, the better the powder is charging.

Daily Operation

Turn on the feed hopper fluidizing air. Wait several minutes for the powder in the feed hopper to become adequately fluidized.

Automatic guns: Turn on the control unit. If the air pressure regulators are set to the proper pressures, the guns will start spraying powder.

Manual guns: Turn on the control unit. Press the button on the end of the control cable to start spraying powder.

5. Maintenance



WARNING: Allow only qualified personnel to perform the following tasks. Observe and follow the safety instructions in this document and all other related documentation.

Perform the following steps daily:



CAUTION: When cleaning the pump or gun, always disconnect the flow-rate and diffuser air tubing from the control unit. Powder could travel through the air tubing and contaminate the solenoid valves, regulators, and gauges in the control unit. Always blow powder into the booth.

1. Remove the powder feed hose from the pump and disconnect the diffuser air tubing from the control unit. Make sure the booth exhaust fan is on. Point the gun into the booth and insert a compressed-air blow gun into the end of the feed hose. Blow out the feed hose and gun.



CAUTION: Never use a knife or other sharp object that will scratch plastic to clean the gun or pump parts. Powder particles will build up on scratches, fuse together on impact, and clog the gun or pump.

2. Disassemble the gun and pump. Clean the parts with low-pressure compressed air and a clean, soft cloth. Refer to *Repair* for gun disassembly instructions. Refer to the pump manual for disassembly instructions.
3. Check all equipment ground connections. Make sure all equipment in the spray area is connected to a true earth ground.

Previous Generation

6. Troubleshooting



WARNING: Allow only qualified personnel to perform the following tasks. Observe and follow the safety instructions in this document and all other related documentation.

This section contains troubleshooting procedures. These procedures cover only the most common problems you may encounter. If you cannot solve the problem with the information given here, contact your local Nordson representative for help.

Problem	Possible Cause	Corrective Action
1. Powder does not flow when gun is triggered	<p>No supply air or supply pressure set too low</p> <p>Flow-rate air pressure set too low</p> <p>Blockage in system</p> <p>Control unit malfunction: solenoid valve not opening</p>	<p>Make sure the control unit is getting compressed air at correct pressure.</p> <p>Increase the flow-rate air pressure.</p> <p>Check the flow-rate air tubing for kinks. Make sure the powder feed hose, pump, and feed hopper pickup tube are not clogged. Make sure the powder and compressed air supplies are clean and dry. Check the fluidizing air pressure.</p> <p>Refer to the control unit manual.</p>
2. Powder puffing from gun	<p>Blockage in system</p> <p>Pump venturi throat worn</p> <p>Diffuser air pressure too high, or incorrect ratio of diffuser to flow-rate air pressure</p> <p>Powder feed hose ID too large or hose too short</p>	<p>Clean the pickup tube, pump, feed hose, and gun. Make sure the powder is not damp. Check the air dryer.</p> <p>Replace the venturi throat.</p> <p>Decrease the diffuser air pressure or increase the flow-rate air pressure.</p> <p>Change to a smaller ID hose or change the hose length. Best results are obtained when the hose is 4-6 meters (13-20 ft) long.</p>

6. Troubleshooting (contd.)

Problem	Possible Cause	Corrective Action
3. Poor powder charging—little or no electrostatic wrap or adhesion	<p>Flow-rate air pressure too high or diffuser air pressure too low</p> <p>Parts not properly grounded</p> <p>Gun not properly broken in</p> <p>Too much moisture in compressed air supply</p> <p>Inner and outer charge sleeves worn</p> <p>Too many fine particles in powder supply</p> <p>Powder not suitable for tribo-charging</p>	<p>Decrease the flow-rate air pressure or increase the diffuser air pressure.</p> <p>Check the part grounds with an ohmmeter. The resistance between the parts and ground should not exceed 1 megohm. For best results the resistance should not exceed 500 ohms.</p> <p>Break in the gun according to instructions in <i>Operation</i>.</p> <p>Check the air dryer for proper operation. Use a refrigerated or regenerative desiccant air dryer that can produce a 3.4 °C (38 °F) or lower dew point at 7 bar (100 psi). Drain the air filter and check the filter element.</p> <p>Disassemble the gun and replace the sleeves. Refer to <i>Repair</i>.</p> <p>Add virgin powder to the feed hopper, or replace the powder in the hopper with virgin powder.</p> <p>Consult with your powder manufacturer.</p>
4. Inadequate powder flow	<p>Flow-rate air pressure too low</p> <p>Blockage in system</p>	<p>Increase the flow-rate air pressure.</p> <p>Clean the pickup tube, pump, feed hose, diffuser, and gun. Make sure the powder is not damp. Check the air dryer.</p>

7. Repair



WARNING: Allow only qualified personnel to perform the following tasks. Observe and follow the safety instructions in this document and all other related documentation.

Service kits are available for

- inner charge sleeve
- outer charge sleeve
- inlet diffuser
- gun body
- bore housing tube

See Figure 5.

1. Clean the gun as described in step 1 in *Maintenance*.
2. Disconnect the ground cable (2) from the gun.
3. Disconnect the powder feed hose and diffuser air tubing from the barbed fittings (11, 12). If you are working on a manual gun, you will have to pull the handle (9) and any extensions off the gun body (8) first.
4. Remove the deflector (28) and nozzle (27).
5. Remove the outer charge sleeve (26) from the bore housing tube (16) with a slight twisting motion.
6. Remove the inner charge sleeve assembly (items 17–24).
7. Unscrew the bore housing tube from the gun body (8 or 13).
8. Pull the inlet diffuser (14) out of the bore housing tube.
9. To disassemble the inner charge sleeve assembly, unscrew the outlet distributor (22 or 24) from the rod (19). Remove the spider (21), inner charge sleeve (20), guide (18), and inlet distributor (17) from the rod.
10. Clean all parts with low-pressure compressed air and a clean cloth. Replace any parts that are worn or damaged.

Reverse the disassembly procedure to reassemble the gun.

NOTE: Before installing the outer charge sleeve into the bore housing tube, apply a small amount of O-ring grease to the sleeve O-rings.

7. Repair (contd.)

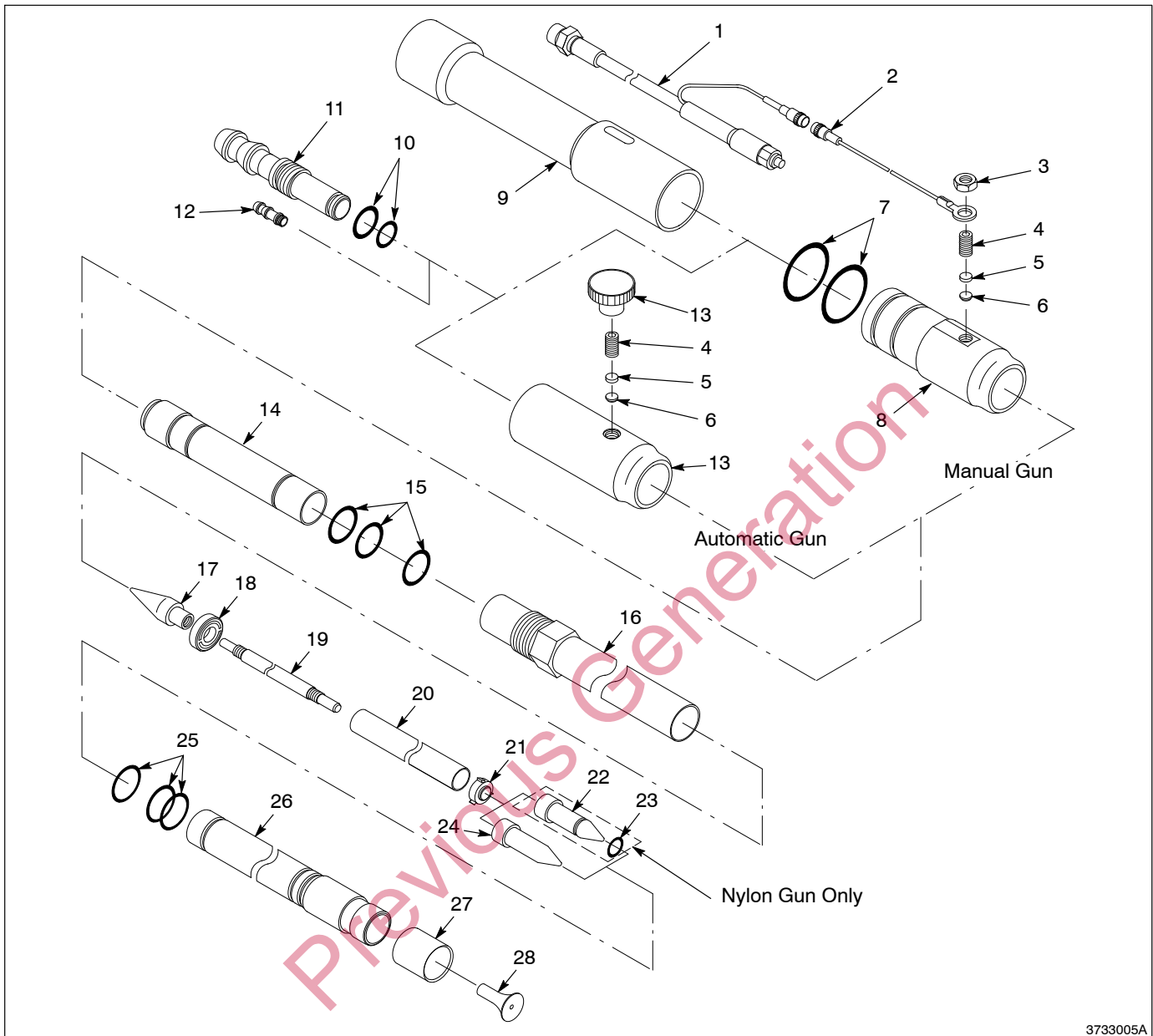

3733005A

Fig. 5 Repair (Components of Both Manual and Automatic Guns Shown)

- | | | |
|------------------------------|-----------------------------------|--|
| 1. Control cable | 11. Barbed fitting (powder) | 20. Inner charge sleeve |
| 2. Ground cable | 12. Barbed fitting (diffuser air) | 21. Spider |
| 3. Jam nut (manual guns) | 13. Clamping knob (auto guns) | 22. Outlet distributor (Nylon guns only) |
| 4. Set screw | 14. Inlet diffuser | 23. O-ring (Nylon guns only) |
| 5. Spring | 15. O-rings (inlet diffuser) | 24. Outlet distributor (PTFE guns) |
| 6. Plunger | 16. Bore housing tube | 25. O-rings (Outer charge sleeve) |
| 7. O-rings (manual gun body) | 17. Inlet distributor | 26. Outer charge sleeve |
| 8. Gun body (manual) | 18. Guide | 27. Nozzle |
| 9. Handle | 19. Rod | 28. Deflector |
| 10. O-rings (inlet fitting) | | |

8. Parts

Use these parts lists and illustrations to locate the parts you need and find their part numbers. To order parts, call the Nordson Customer Service Center or your local Nordson representative.

Using the Illustrated Parts List

Numbers in the Item column correspond to numbers that identify parts in illustrations following each parts list. The code NS (not shown) indicates that a listed part is not illustrated. A dash (—) is used when the part number applies to all parts in the illustration.

The six-digit number in the Part column is the Nordson Corporation part number. A series of dashes in this column (- - - - -) means the part cannot be ordered separately.

The Description column gives the part name, as well as its dimensions and other characteristics when appropriate. Indentions show the relationships between assemblies, subassemblies, and parts.

Item	Part	Description	Quantity	Note
—	000 000	Assembly	1	
1	000 000	• Subassembly	2	A
2	000 000	• • Part	1	

- If you order the assembly, items 1 and 2 will be included.
- If you order item 1, item 2 will be included.
- If you order item 2, you will receive item 2 only.

The number in the Quantity column is the quantity required per unit, assembly, or subassembly. The code AR (As Required) is used if the part number is a bulk item ordered in quantities or if the quantity per assembly depends on the product version or model.

Letters in the Note column refer to notes at the end of each parts list. Notes contain important information about usage and ordering. Special attention should be given to notes.

PTFE Automatic Spray Gun

See Figure 6.

Item	Part	Description	Quantity	Note
—	224 019	Gun, tribo wand, auto, PTFE	1	
1	224 040	• Fitting, male barb, connector	1	A
2	224 024	• Fitting, inlet	1	A
3	940 144	• O-ring, Buna-N, 0.500 x 0.625 x 0.063 in.	1	A
4	940 129	• O-ring, silicone, conductive, 0.375 x 0.500 in.	1	A
5	139 374	• Knob, clamping	1	A
6	981 212	• Screw, socket, set, 1/4-20 x 0.375 in., cup	1	A
7	307 498	• Spring, ground, conductive silicone	1	A
8	307 476	• Plunger, ground	1	A
9	-----	• Body, auto gun	1	A
10	-----	• Diffuser, inlet	1	B
11	941 154	• O-ring, silicone, conductive, 0.688 x 0.875 in.	1	B
12	941 131	• O-ring, silicone, 0.563 x 0.688 x 0.094 in.	2	B
13	326 638	• Kit, tube, bore housing	1	
14	224 026	• Distributor, inlet, PTFE	1	C
15	224 025	• Guide, inner charge	1	C
16	224 038	• Rod, inner charge support	1	C
17	224 039	• Sleeve, inner charge	1	C
18	224 035	• Spider, inner charge guide	1	C
19	224 030	• Distributor, outlet, PTFE	1	C
20	940 165	• O-ring, silicone, conductive, 0.625 x 0.750 in.	3	D
21	-----	• Sleeve, outer charge	1	D
22	224 031	• Nozzle, outlet sleeve	1	
23	307 486	• Deflector, conical, 32 mm	1	
24	307 496	• Deflector, conical, 19 mm	1	

NOTE A: Included in auto gun body kit, part 326 639.

B: Included in PTFE inlet diffuser kit, part 326 642.

C: Included in PTFE inner charge kit, part 326 640.

D: Included in PTFE outer charge kit, part 326 641.

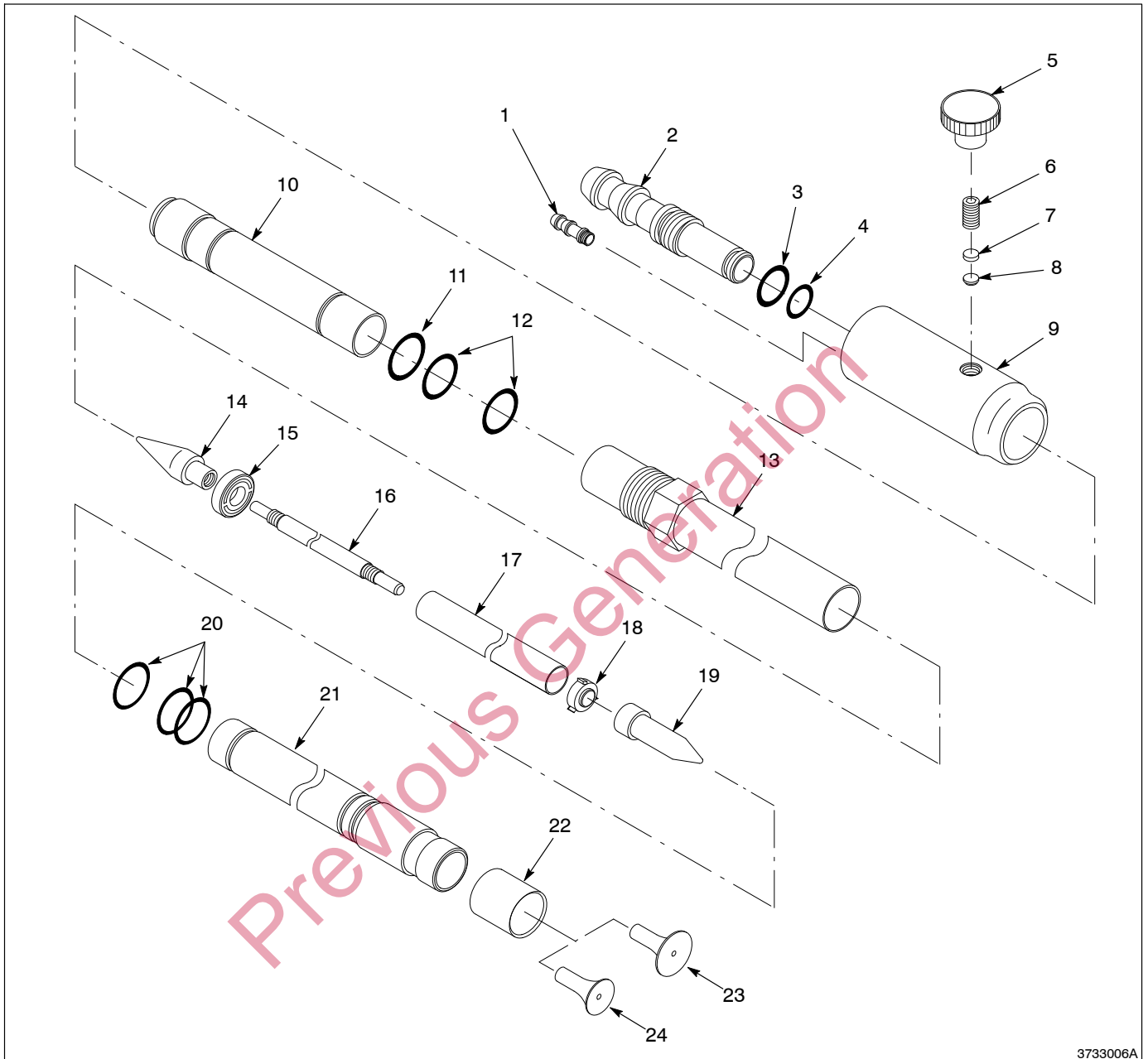

3733006A

Fig. 6 PTFE Automatic Gun Parts

Nylon Automatic Spray Gun

See Figure 7.

Item	Part	Description	Quantity	Note
—	307 452	Gun, tribo wand, auto, Nylon	1	
1	224 040	• Fitting, male barb, connector	1	A
2	224 024	• Fitting, inlet	1	A
3	940 144	• O-ring, Buna-N, 0.500 x 0.625 x 0.063 in.	1	A
4	940 129	• O-ring, silicone, conductive, 0.375 x 0.500 in.	1	A
5	139 374	• Knob, clamping	1	A
6	981 212	• Screw, socket, set, 1/4-20 x 0.375 in., cup	1	A
7	307 498	• Spring, ground, conductive silicone	1	A
8	307 476	• Plunger, ground	1	A
9	-----	• Body, auto gun	1	A
10	307 459	• Diffuser, inlet, Nylon	1	B
11	941 154	• O-ring, silicone, conductive, 0.688 x 0.875 in.	1	B
12	941 131	• O-ring, silicone, 0.563 x 0.688 x 0.094 in.	2	B
13	326 638	• Kit, tube, bore housing	1	
14	307 457	• Distributor, inlet, Nylon	1	C
15	307 482	• Guide, inner charge, Nylon	1	C
16	224 038	• Rod, inner charge support	1	C
17	307 465	• Sleeve, inner charge, Nylon	1	C
18	307 464	• Spider, inner charge guide, Nylon	1	C
19	307 463	• Distributor, outlet, Nylon	1	C
19A	940 093	• O-ring, silicone, 0.188 x 0.312 x 0.063 in.	1	C
20	940 165	• O-ring, silicone, conductive, 0.625 x 0.750 in.	3	D
21	307 456	• Sleeve, outer charge, Nylon	1	D
22	307 460	• Nozzle, outlet sleeve, Nylon	1	
23	307 468	• Deflector, conical, Nylon, 32 mm	1	
24	307 488	• Deflector, conical, Nylon, 19 mm	1	

NOTE A: Included in auto gun body kit, part 326 639.

B: Included in Nylon inlet diffuser kit, part 326 643.

C: Included in Nylon inner charge kit, part 326 645.

D: Included in Nylon outer charge kit, part 326 646.

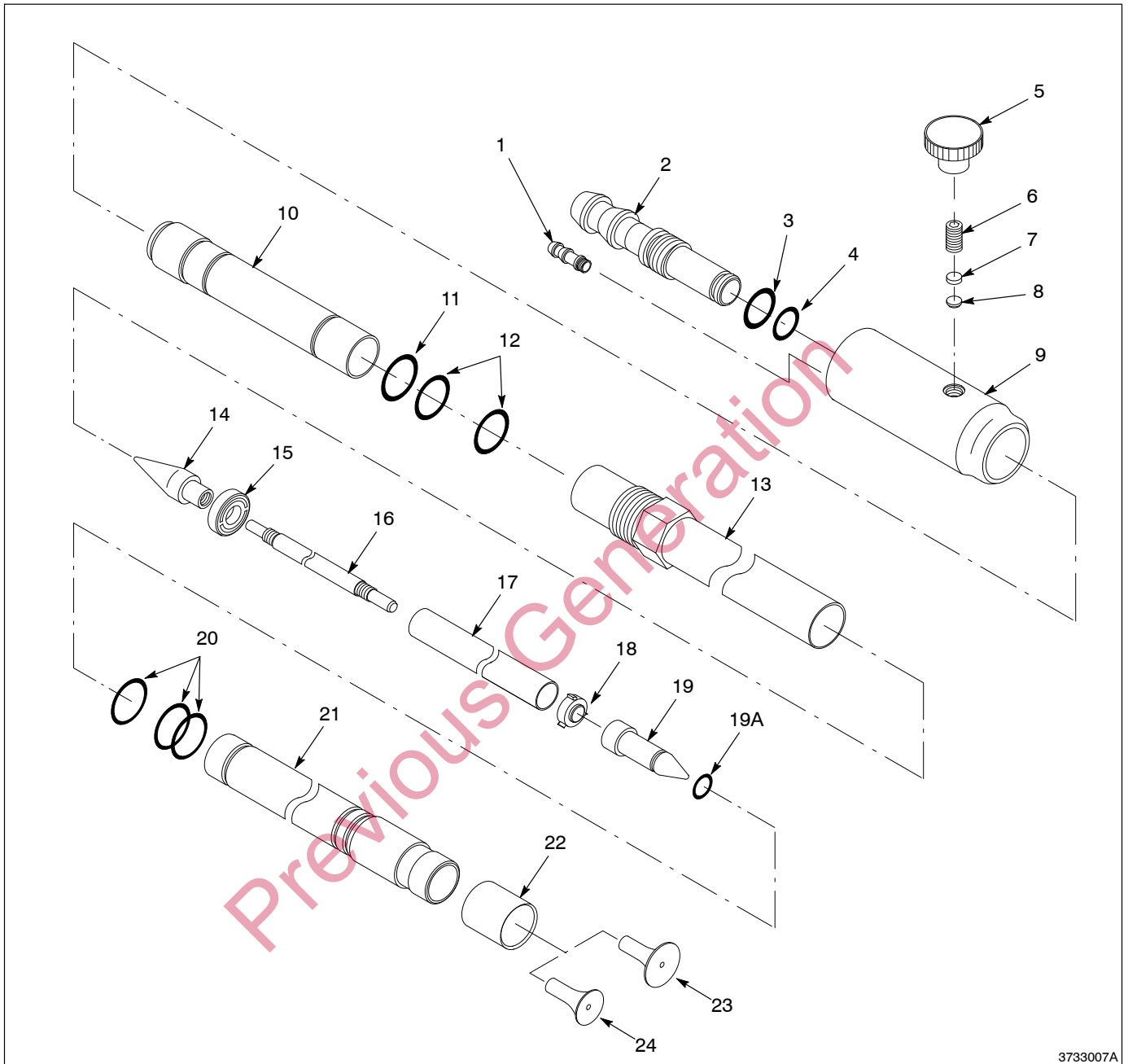

3733007A

Fig. 7 Nylon Automatic Gun Parts

PTFE Manual Spray Gun

See Figure 8.

Item	Part	Description	Quantity	Note
—	307 451	Gun, tribo wand, manual, PTFE	1	
1	307 481	• Cable, control, tribo wand	1	
2	307 483	• Cable, ground, tribo wand	1	
3	984 210	• Nut, hex, jam, 1/4-20	1	A
4	981 212	• Screw, socket, set, 1/4-20 x 0.375 in., cup	1	A
5	307 498	• Spring, ground, conductive silicone	1	A
6	307 476	• Plunger, ground	1	A
7	307 466	• Handle, gun body	1	
8	224 040	• Fitting, male barb, connector	1	A
9	224 024	• Fitting, inlet	1	A
10	940 144	• O-ring, Buna-N, 0.500 x 0.625 x 0.063 in.	1	A
11	940 129	• O-ring, silicone, conductive, 0.375 x 0.500 in.	1	A
12	941 230	• O-ring, Viton, 1.188 x 1.375 x 0.094 in.	2	A
13	-----	• Body, auto gun	1	A
14	-----	• Diffuser, inlet	1	B
15	941 154	• O-ring, silicone, conductive, 0.688 x 0.875 in.	1	B
16	941 131	• O-ring, silicone, 0.563 x 0.688 x 0.094 in.	2	B
17	326 638	• Kit, tube, bore housing	1	
18	224 026	• Distributor, inlet	1	C
19	224 025	• Guide, inner charge	1	C
20	224 038	• Rod, inner charge support	1	C
21	224 039	• Sleeve, inner charge	1	C
22	224 035	• Spider, inner charge guide	1	C
23	224 030	• Distributor, outlet	1	C
24	940 165	• O-ring, silicone, conductive, 0.625 x 0.750 in.	3	D
25	-----	• Sleeve, outer charge	1	D
26	224 031	• Nozzle, outlet sleeve	1	
27	307 486	• Deflector, conical, 32 mm	1	
28	307 496	• Deflector, conical, 19 mm	1	

NOTE A: Included in auto gun body kit, part 326 639.

B: Included in PTFE inlet diffuser kit, part 326 642.

C: Included in PTFE inner charge kit, part 326 640.

D: Included in PTFE outer charge kit, part 326 641.

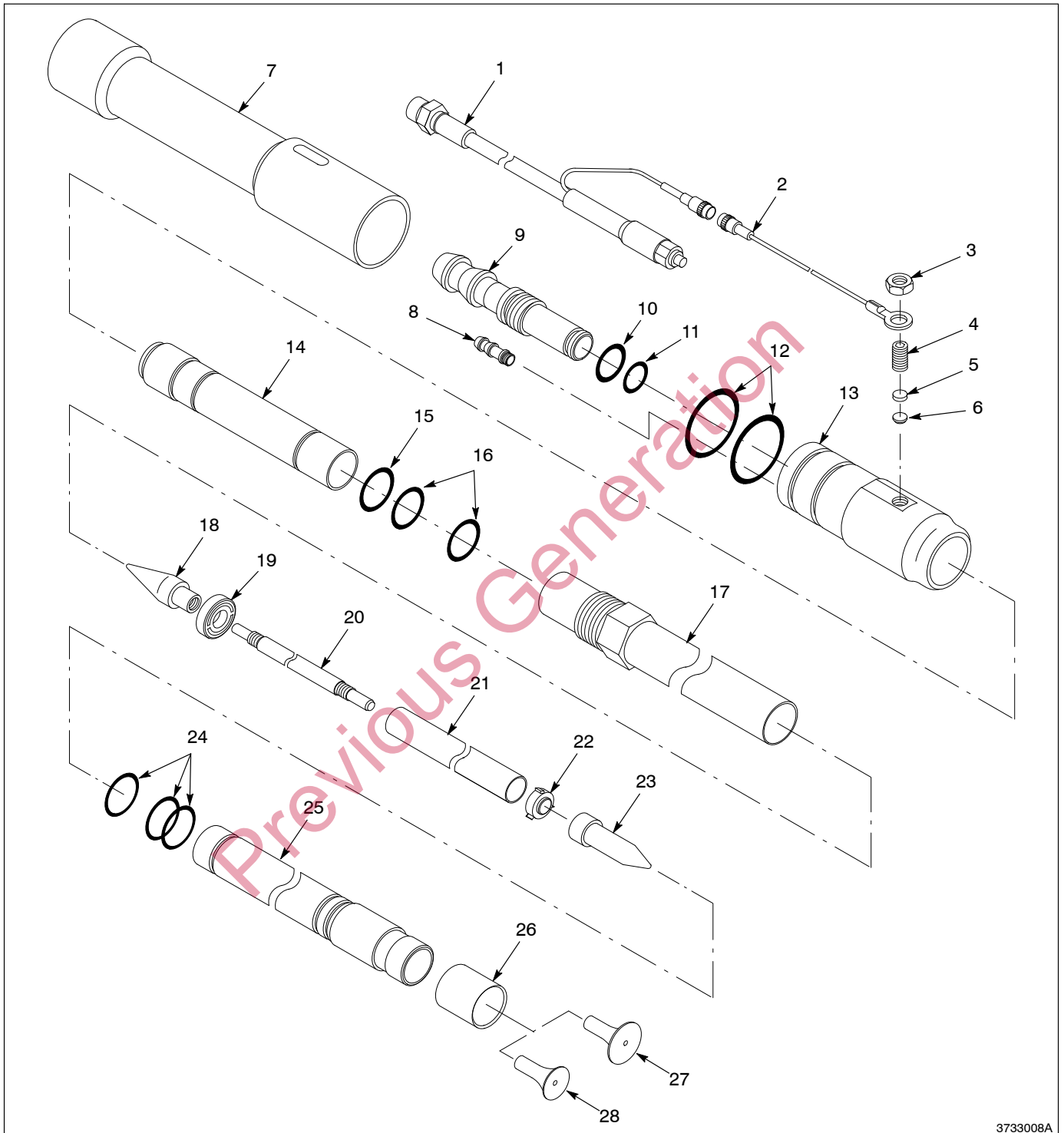

3733008A

Fig. 8 PTFE Manual Gun Parts

Nylon Manual Spray Gun

See Figure 9.

Item	Part	Description	Quantity	Note
—	307 453	Gun, tribo wand, manual, Nylon	1	
1	307 481	• Cable, control, tribo wand	1	
2	307 483	• Cable, ground, tribo wand	1	
3	984 210	• Nut, hex, jam, 1/4-20	1	A
4	981 212	• Screw, socket, set, 1/4-20 x 0.375 in., cup	1	A
5	307 498	• Spring, ground, conductive silicone	1	A
6	307 476	• Plunger, ground	1	A
7	307 466	• Handle, gun body	1	
8	224 040	• Fitting, male barb, connector	1	A
9	224 024	• Fitting, inlet	1	A
10	940 144	• O-ring, Buna-N, 0.500 x 0.625 x 0.063 in.	1	A
11	940 129	• O-ring, silicone, conductive, 0.375 x 0.500 in.	1	A
12	941 230	• O-ring, Viton, 1.188 x 1.375 x 0.094 in.	2	A
13	-----	• Body, auto gun	1	A
14	307 459	• Diffuser, inlet, Nylon	1	B
15	941 154	• O-ring, silicone, conductive, 0.688 x 0.875 in.	1	B
16	941 131	• O-ring, silicone, 0.563 x 0.688 x 0.094 in.	2	B
17	326 638	• Kit, tube, bore housing	1	
18	307 457	• Distributor, inlet, Nylon	1	C
19	307 482	• Guide, inner charge, Nylon	1	C
20	224 038	• Rod, inner charge support	1	C
21	307 465	• Sleeve, inner charge, Nylon	1	C
22	307 464	• Spider, inner charge guide, Nylon	1	C
23	307 463	• Distributor, outlet, Nylon	1	C
23A	940 093	• O-ring, silicone, 0.188 x 0.312 x 0.063 in.	1	C
24	940 165	• O-ring, silicone, conductive, 0.625 x 0.750 in.	3	D
25	307 456	• Sleeve, outer charge, Nylon	1	D
26	307 460	• Nozzle, outlet sleeve, Nylon	1	
27	307 468	• Deflector, conical, Nylon, 32 mm	1	
28	307 488	• Deflector, conical, Nylon, 19 mm	1	

NOTE A: Included in auto gun body kit, part 326 639.

B: Included in PTFE inlet diffuser kit, part 326 643.

C: Included in PTFE inner charge kit, part 326 645.

D: Included in PTFE outer charge kit, part 326 646.

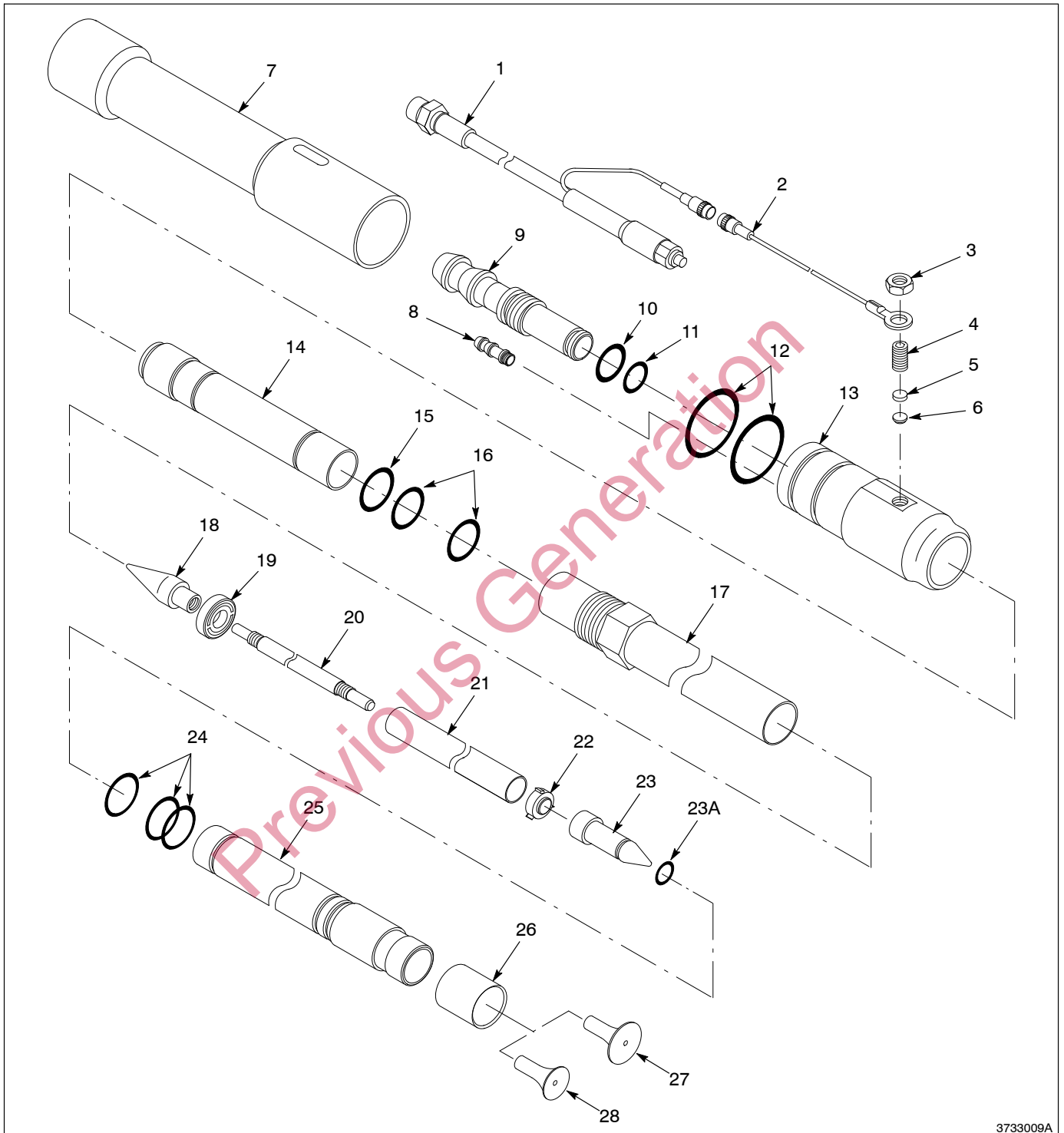

3733009A

Fig. 9 Nylon Manual Gun Parts

Service Kits List

Contents of these kits are shown in the guns parts lists. Refer to the Notes column.

All Gun Versions

Part	Description
326 638	Bore housing tube kit

Gun Body Kits

Part	Description
326 639	Automatic gun body kit
326 644	Manual gun body kit

PTFE Gun Kits

Part	Description
326 640	Inner charge sleeve kit
326 641	Outer charge sleeve kit
326 642	Inlet diffuser kit

Nylon Gun Kits

Part	Description
326 645	Inner charge sleeve kit
326 646	Outer charge sleeve kit
326 643	Inlet diffuser kit

Accessories

Accessories must be ordered separately. If you order any deflectors, pattern adjuster sleeves, or slotted nozzles, make sure they are made from the correct material for your gun.

Deflectors

See Figure 10 for PTFE and Nylon deflectors.

Item	Part	Description	Quantity	Note
1	307 489	Deflector, conical, 11 mm, PTFE	1	A
2	307 485	Deflector, conical, 24 mm, PTFE	1	
3	307 495	Deflector, conical, 44 mm, PTFE	1	
4	224 020	Deflector, conical, forward, 25 mm, PTFE	1	

NOTE A: This deflector is used only with the pattern adjuster sleeves listed on the following page.

Item	Part	Description	Quantity	Note
1	307 479	Deflector, conical, 11 mm, Nylon	1	A
2	307 461	Deflector, conical, 24 mm, Nylon	1	
3	307 462	Deflector, conical, 44 mm, Nylon	1	

NOTE A: This deflector is used only with the pattern adjuster sleeves listed on the following page.

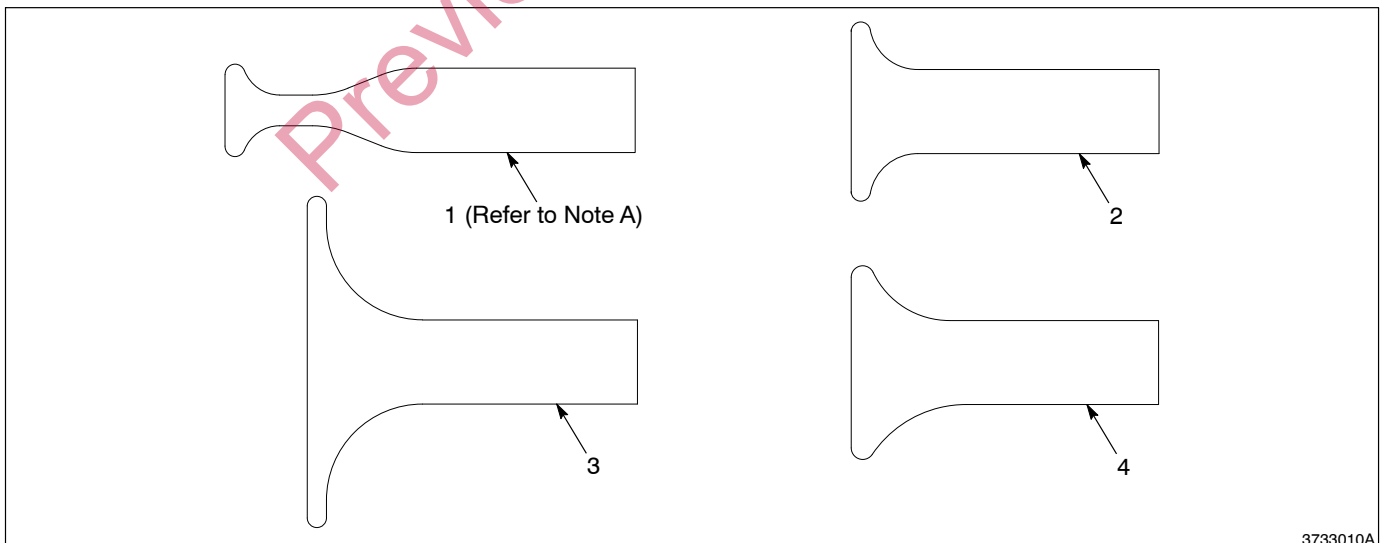

3733010A

Fig. 10 PTFE and Nylon Deflectors

Pattern Adjuster Sleeves

See Figure 11 for PTFE and Nylon pattern adjuster sleeves.

Item	Part	Description	Quantity	Note
1	307 492	Sleeve, pattern adjuster, PTFE	1	A
2	940 182	• O-ring, silicone, 0.750 x 0.875 x 0.063 in.	1	
3	307 491	Sleeve, pattern adjuster, 1 in. ID, PTFE	1	A
4	940 182	• O-ring, silicone, 0.750 x 0.875 x 0.063 in.	1	
5	307 490	Sleeve, small pattern, PTFE	1	A

NOTE A: Use deflector 307 489 with these pattern adjuster sleeves.

Item	Part	Description	Quantity	Note
1	307 494	Sleeve, pattern adjuster, Nylon	1	A
2	940 182	• O-ring, silicone, 0.750 x 0.875 x 0.063 in.	1	
3	307 493	Sleeve, pattern adjuster, 1 in. ID, Nylon	1	A
4	940 182	• O-ring, silicone, 0.750 x 0.875 x 0.063 in.	1	
5	307 484	Sleeve, small pattern, Nylon	1	A

NOTE A: Use deflector 307 479 with these pattern adjuster sleeves.

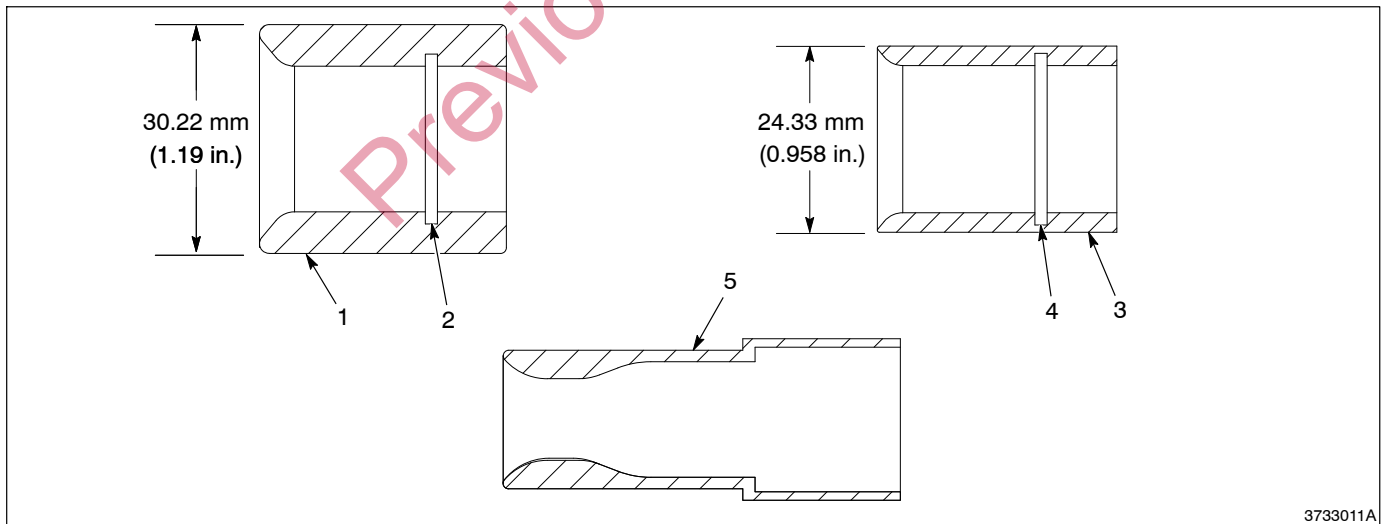

3733011A

Fig. 11 PTFE and Nylon Pattern Adjuster Sleeves

Slotted Nozzles

See Figure 12 for PTFE and Nylon slotted nozzles.

Item	Part	Description	Quantity	Note
1	224 021	Nozzle, conical, slotted, PTFE	1	
1	307 471	Nozzle, conical, slotted, Nylon	1	
2	224 034	Nozzle, slotted, PTFE	1	

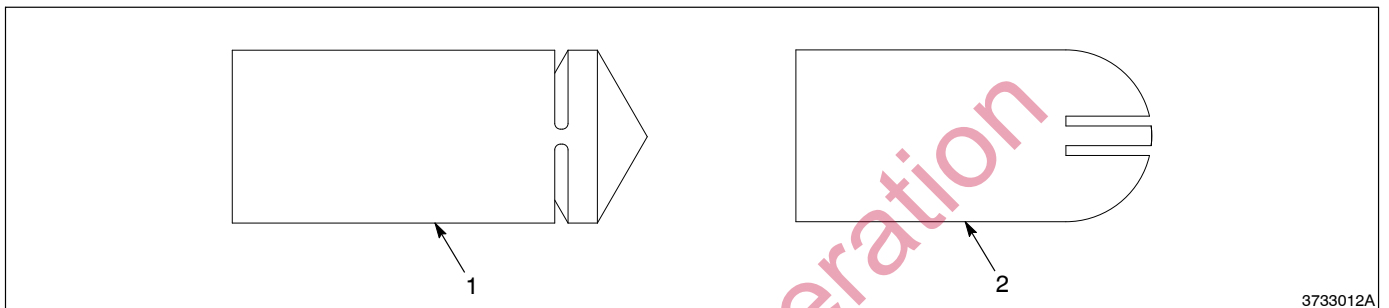

3733012A

Fig. 12 PTFE and Nylon Slotted Nozzles

Extensions

See Figure 13. Extensions are installed into the end of the manual gun handle.

Item	Part	Description	Quantity	Note
1	307 469	Adapter, handle, 24 in. extension	1	
2	307 470	Adapter, handle, 60 in. extension	1	

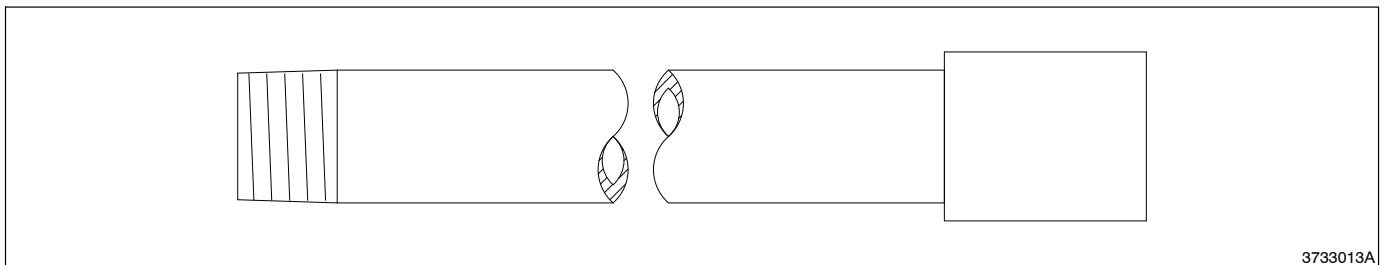

3733013A

Fig. 13 Extensions

Guide

See Figure 14. The guide installs on the bore housing tube. It allows a manual gun operator to steady the gun while spraying.

Item	Part	Description	Quantity	Note
1	307 473	Guide, locator, 2 in. center	1	

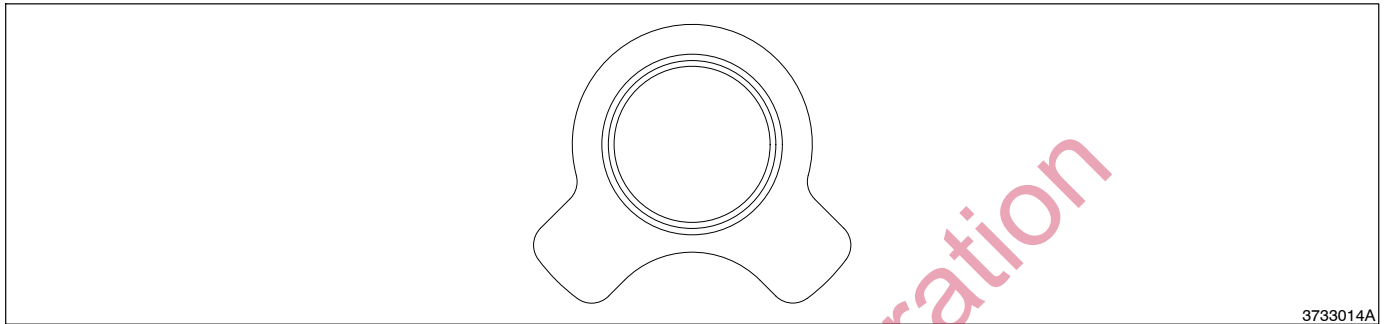

Fig. 14 Guide

Previous Generation