

Sure Coat Powder Spray Gun Electrode Kit



WARNING: Allow only qualified personnel to perform the following tasks. Follow the safety instructions in this document and all other related documentation.

1. Removing Old Electrode



WARNING: Turn off the electrostatic voltage and ground the gun electrode before performing the following tasks. Failure to observe this warning could result in a shock.

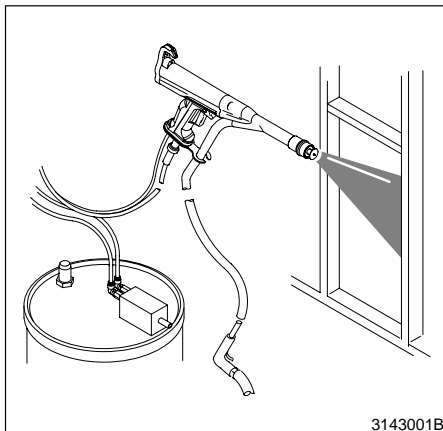

Fig. 1 Purging the Gun

1. See Figure 1. Disconnect the powder feed hose from the pump.
2. Point the gun into the booth.
3. Blow the powder out of the hose and gun with OSHA-approved low-pressure compressed air.
4. Disconnect the powder feed hose from the adapter.

5. See Figure 2. Remove the hose adapter (8) from the powder inlet body (3).
6. Loosen the set screw (4) in the underside of the powder inlet body.
7. Remove the nozzle parts (5, 6, 7) from the powder inlet body.
8. Slide the powder inlet body off of the electrode assembly (2) and gun body (1).
9. Unscrew the old electrode assembly from the gun body.

1. Removing Old Electrode

(contd.)

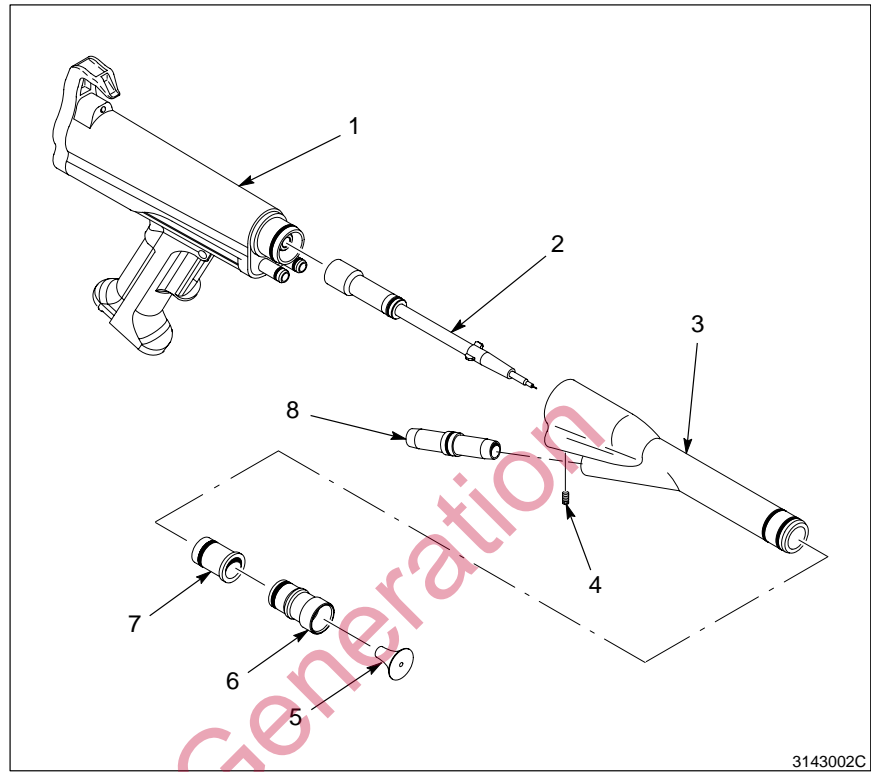

Fig. 2 Removing the Electrode Assembly

- | | |
|-----------------------|---------------------|
| 1. Gun body | 5. Deflector |
| 2. Electrode assembly | 6. Pattern adjuster |
| 3. Powder inlet body | 7. Nozzle adapter |
| 4. Set screw | 8. Hose adapter |

2. Installing New Electrode



WARNING: Do not leave powder or contaminants in the gun body or on the end of the electrode assembly. Failure to remove powder build-up or contaminants may result in internal damage, sparking, and/or injury to personnel.

1. Remove the shipping container and protective caps from the new electrode assembly.
2. See Figure 2. Thread the new electrode assembly (2) onto the gun body (1) until snug.
3. Reassemble the gun and reconnect the powder feed hose.

3. Parts

See Figure 3. Use the following parts list to order replacement components for your Sure Coat manual powder spray gun electrode assembly.

Item	Part	Part	Description	Quantity	Note
—	288 567		Electrode, handgun, standard, packaged	1	
—		288 573	Electrode, handgun, short, packaged	1	
1	941 081	941 081	• O-ring, silicone, 0.250 x 0.438 x 0.094 in.	1	
2	288 557	288 557	• Support, electrode, handgun	1	
3	940 163	940 163	• O-ring, silicone, 0.625 x 0.750 x 0.063 in.	1	
4	288 555	288 572	• Sleeve, wear	1	
5	-----	-----	• Cable, core	AR	
6	288 560	288 560	• Electrode, spring, contact	1	
7	288 554	288 554	• Holder, cable, electrode	1	

AR: As Required

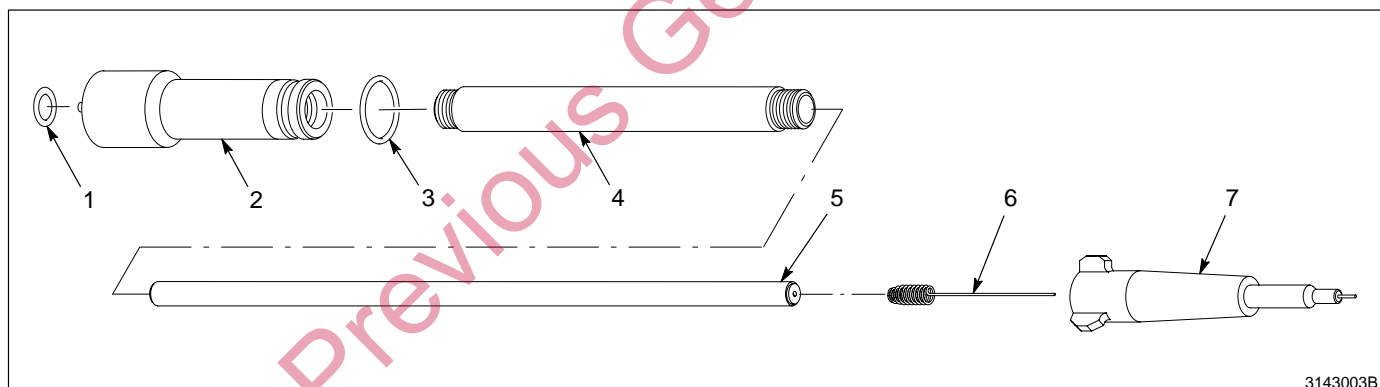

Fig. 3 Sure Coat Electrode Kits

Original copyright date 1997. Sure Coat, Nordson and the Nordson logo are registered trademarks of Nordson Corporation.

Previous Generation