

Encore[®] XT Manual Powder Spray Systems

Customer Product Manual

Part 1600820-04

Issued 10/25

**For parts and technical support, call the
Finishing Customer Support Center at (800) 433-9319.**

This document is subject to change without notice.
Check <http://emanuals.nordson.com/finishing> for the latest version.



NORDSON CORPORATION • AMHERST, OHIO • USA

Previous Generation

Contact Us

Nordson Corporation welcomes requests for information, comments, and inquiries about its products. General information about Nordson can be found on the Internet using the following address:
<http://www.nordson.com>.

Address all correspondence to:

Nordson Corporation
Attn: Customer Service
555 Jackson Street
Amherst, OH 44001

Notice

This is a Nordson Corporation publication which is protected by copyright. Original copyright date 2012. No part of this document may be photocopied, reproduced, or translated to another language without the prior written consent of Nordson Corporation. The information contained in this publication is subject to change without notice.

Trademarks

Encore, Nordson, and the Nordson logo are registered trademarks of Nordson Corporation.

Betasolv is a registered trademark of Oakite Corporation, Inc. All other trademarks are the property of their respective owners.

Table of Contents

Safety	1-1
Introduction	1-1
Qualified Personnel	1-1
Intended Use	1-1
Regulations and Approvals	1-1
Personal Safety	1-2
Fire Safety	1-2
Grounding	1-3
Action in the Event of a Malfunction	1-3
Disposal	1-3
Description	2-1
Introduction	2-1
Mobile System Components	2-2
Rail-Mount System Components	2-2
Wall-Mount System Components	2-2
Specifications	2-3
Mobile System with VBF	2-3
Mobile System with 50 lb. Feed Hopper	2-3
Mobile System with 25 lb. Feed Hopper	2-3
Equipment Labels	2-4
Applicator Certification Label	2-4
Power Unit and Gun Interface Controllers Certification Label	2-4
System Setup	3-1
Wall/Rail Mount Systems	3-1
Controller Wall Mount	3-1
Controller Rail Mount	3-2
Interconnect Cable Connection	3-3
System Connections	3-4
System Diagram	3-4
Controller Connections	3-5
VBF System Setup	3-6
Pickup Tube and Pump Installation	3-6
Hopper and Wall/Rail Mount System Setup	3-7
Hopper Installation – Mobile Systems	3-7
Wall/Rail Mount System Hopper Installation	3-8
Pump Mounting – Feed Hoppers	3-8
Adapter Installation	3-8
Coupling Installation	3-8
Pump Connections	3-9
Wall/Rail Mount Power Unit Connections	3-10
Spray Gun Connections	3-10
Gun Cable	3-10
Air Tubing and Powder Hose	3-11
Bundling Tubing and Cable	3-11

System Air and Electrical Connections	3-12
Mobile System Air Supply	3-12
Wall / Rail Mount System Air Supply	3-13
Electrical Connections	3-13
System Ground	3-14
Mobile Systems	3-14
Wall / Rail Mount Systems	3-14
Operation	4-1
European Union, ATEX, Special Conditions for Safe Use	4-1
VBF Powder Box Installation	4-1
Feed Hopper Filling	4-2
Spray Gun Operation	4-3
Changing Presets with the Settings Trigger	4-3
Changing Powder Flow with the Settings Trigger	4-3
Purging the Spray Gun	4-3
Fluidizing Air Operation	4-4
Powder Feed Hopper	4-4
Vibratory Box Feeder	4-4
Electrode Air Wash Operation	4-5
Daily Operation	4-5
Initial Startup	4-5
Startup	4-5
Standby Button	4-7
Factory Set Presets	4-7
Changing Flat Spray Nozzles	4-7
Changing Deflectors or Conical Nozzles	4-8
Installing the Optional Pattern Adjuster Kit	4-8
Shutdown	4-9
Maintenance	4-9
Recommended Cleaning Procedure for Powder Contact Parts	4-9
Maintenance Procedures	4-10
Using the Controller Interface	4-11
Interface Components	4-11
Help Codes	4-12
Maintenance Timer, Total Hours, and Software Versions	4-12
Presets	4-13
Selecting a Preset	4-13
Electrostatic Settings	4-13
Select Charge® Mode	4-13
Custom Mode	4-14
Classic Mode	4-14
Classic Standard (STD) Mode	4-14
Classic AFC Mode	4-15
Powder Flow Settings	4-15
Smart Flow Mode	4-16
Setting Smart Flow Setpoints	4-17
Smart Flow Settings – Metric Units	4-18
Smart Flow Settings – English Units	4-19
Classic Flow Mode Settings	4-20
Controller Configuration	4-20
Opening the Function Menu and Making Settings	4-20
Vibratory Box Feeder On Continuously	4-21
Saving and Loading Preset and Function Settings	4-22
Setting the Number of Presets	4-22

Troubleshooting	5-1
Help Code Troubleshooting	5-1
Viewing Help Codes	5-1
Clearing Help Codes	5-1
Help Code Troubleshooting Chart	5-2
General Troubleshooting Chart	5-5
Re-Zero Procedure	5-9
Spray Gun Power Supply Resistance Test	5-10
Electrode Assembly Resistance Test	5-10
Gun Cable Continuity Test	5-11
Controller Interconnect Cable Test	5-11
System Wiring Diagrams	5-12
Repair	6-1
Spray Gun Repair	6-1
Display Module Replacement	6-2
Display Module Removal	6-2
Display Module Installation	6-2
Power Supply and Powder Path Replacement	6-3
Gun Disassembly	6-3
Power Supply Replacement	6-4
Powder Path Replacement	6-5
Powder Path Installation	6-5
Gun Re-assembly	6-6
Cable Replacement	6-7
Cable Removal	6-7
Cable Installation	6-7
Trigger Switch Replacement	6-8
Switch Removal	6-8
Switch Installation	6-9
Interface Module Repair	6-10
Power Unit Repair	6-11
Removing the Sub-Panel	6-11
Sub-Panel Components	6-12
Regulator Adjustment	6-12
iFlow Module Repair	6-13
Testing iFlow Modules	6-14
Solenoid Valve Replacement	6-15
Proportional Valve Cleaning	6-15
Proportional Valve Replacement	6-17
Vibrator Motor Replacement	6-17
Parts	7-1
Introduction	7-1
System Part Numbers	7-1
Spray Gun Parts	7-1
Spray Gun Parts Illustration	7-2
Spray Gun Parts List	7-3
Spray Gun Options	7-5
Miscellaneous Spray Gun Options	7-5
Flat Spray Nozzles	7-5
Conical Nozzle and Deflectors	7-6
Cross Cut Nozzles	7-6
Pattern Adjuster Kit	7-7
Lance Extensions	7-7
Pattern Adjuster Kit for Lance Extensions	7-7

Controller Parts	7-8
Interface Exploded View	7-8
Interface Parts List	7-9
Power Unit Exploded View	7-10
Power Unit Parts List	7-11
iFlow Module Exploded View and Parts List	7-12
System Components and Parts	7-13
System Parts	7-13
Powder Hose and Air Tubing	7-14
Miscellaneous Options	7-15
Cup Gun	7-15
Pump Parts	7-16
Coupling and Pump Adapter Kit	7-16

Previous Generation

Previous Generation

Section 1

Safety

Introduction

Read and follow these safety instructions. Task- and equipment-specific warnings, cautions, and instructions are included in equipment documentation where appropriate.

Make sure all equipment documentation, including these instructions, is accessible to all persons operating or servicing equipment.

Qualified Personnel

Equipment owners are responsible for making sure that Nordson equipment is installed, operated, and serviced by qualified personnel. Qualified personnel are those employees or contractors who are trained to safely perform their assigned tasks. They are familiar with all relevant safety rules and regulations and are physically capable of performing their assigned tasks.

Intended Use

Use of Nordson equipment in ways other than those described in the documentation supplied with the equipment may result in injury to persons or damage to property.

Some examples of unintended use of equipment include

- using incompatible materials
- making unauthorized modifications
- removing or bypassing safety guards or interlocks
- using incompatible or damaged parts
- using unapproved auxiliary equipment
- operating equipment in excess of maximum ratings

Regulations and Approvals

Make sure all equipment is rated and approved for the environment in which it is used. Any approvals obtained for Nordson equipment will be voided if instructions for installation, operation, and service are not followed.

All phases of equipment installation must comply with all federal, state, and local codes.

Personal Safety

To prevent injury follow these instructions.

- Do not operate or service equipment unless you are qualified.
- Do not operate equipment unless safety guards, doors, or covers are intact and automatic interlocks are operating properly. Do not bypass or disarm any safety devices.
- Keep clear of moving equipment. Before adjusting or servicing any moving equipment, shut off the power supply and wait until the equipment comes to a complete stop. Lock out power and secure the equipment to prevent unexpected movement.
- Relieve (bleed off) hydraulic and pneumatic pressure before adjusting or servicing pressurized systems or components. Disconnect, lock out, and tag switches before servicing electrical equipment.
- Obtain and read Material Safety Data Sheets (MSDS) for all materials used. Follow the manufacturer's instructions for safe handling and use of materials, and use recommended personal protection devices.
- To prevent injury, be aware of less-obvious dangers in the workplace that often cannot be completely eliminated, such as hot surfaces, sharp edges, energized electrical circuits, and moving parts that cannot be enclosed or otherwise guarded for practical reasons.

Fire Safety

To avoid a fire or explosion, follow these instructions.

- Do not smoke, weld, grind, or use open flames where flammable materials are being used or stored.
- Provide adequate ventilation to prevent dangerous concentrations of volatile materials or vapors. Refer to local codes or your material MSDS for guidance.
- Do not disconnect live electrical circuits while working with flammable materials. Shut off power at a disconnect switch first to prevent sparking.
- Know where emergency stop buttons, shutoff valves, and fire extinguishers are located. If a fire starts in a spray booth, immediately shut off the spray system and exhaust fans.
- Clean, maintain, test, and repair equipment according to the instructions in your equipment documentation.
- Use only replacement parts that are designed for use with original equipment. Contact your Nordson representative for parts information and advice.

Grounding



WARNING: Operating faulty electrostatic equipment is hazardous and can cause electrocution, fire, or explosion. Make resistance checks part of your periodic maintenance program. If you receive even a slight electrical shock or notice static sparking or arcing, shut down all electrical or electrostatic equipment immediately. Do not restart the equipment until the problem has been identified and corrected.

Grounding inside and around the booth openings must comply with NFPA requirements for Class II, Division 1 or 2 Hazardous Locations. Refer to NFPA 33, NFPA 70 (NEC articles 500, 502, and 516), and NFPA 77, latest conditions.

- All electrically conductive objects in the spray areas shall be electrically connected to ground with a resistance of not more than 1 megohm as measured with an instrument that applies at least 500 volts to the circuit being evaluated.
- Equipment to be grounded includes, but is not limited to, the floor of the spray area, operator platforms, hoppers, photoeye supports, and blow-off nozzles. Personnel working in the spray area must be grounded.
- There is a possible ignition potential from the charged human body. Personnel standing on a painted surface, such as an operator platform, or wearing non-conductive shoes, are not grounded. Personnel must wear shoes with conductive soles or use a ground strap to maintain a connection to ground when working with or around electrostatic equipment.
- Operators must maintain skin-to-handle contact between their hand and the gun handle to prevent shocks while operating manual electrostatic spray guns. If gloves must be worn, cut away the palm or fingers, wear electrically conductive gloves, or wear a grounding strap connected to the gun handle or other true earth ground.
- Shut off electrostatic power supplies and ground gun electrodes before making adjustments or cleaning powder spray guns.
- Connect all disconnected equipment, ground cables, and wires after servicing equipment.

Action in the Event of a Malfunction

If a system or any equipment in a system malfunctions, shut off the system immediately and perform the following steps:

- Disconnect and lock out electrical power. Close pneumatic shutoff valves and relieve pressures.
- Identify the reason for the malfunction and correct it before restarting the equipment.

Disposal

Dispose of equipment and materials used in operation and servicing according to local codes.

Previous Generation

Section 2

Description

Introduction

See Figure 2-1. This manual covers all versions of the Encore XT Manual Powder Spray System:

- Mobile system with vibratory box feeder (VBF)
- Mobile system with feed hopper
- Rail-mount system
- Wall-mount system

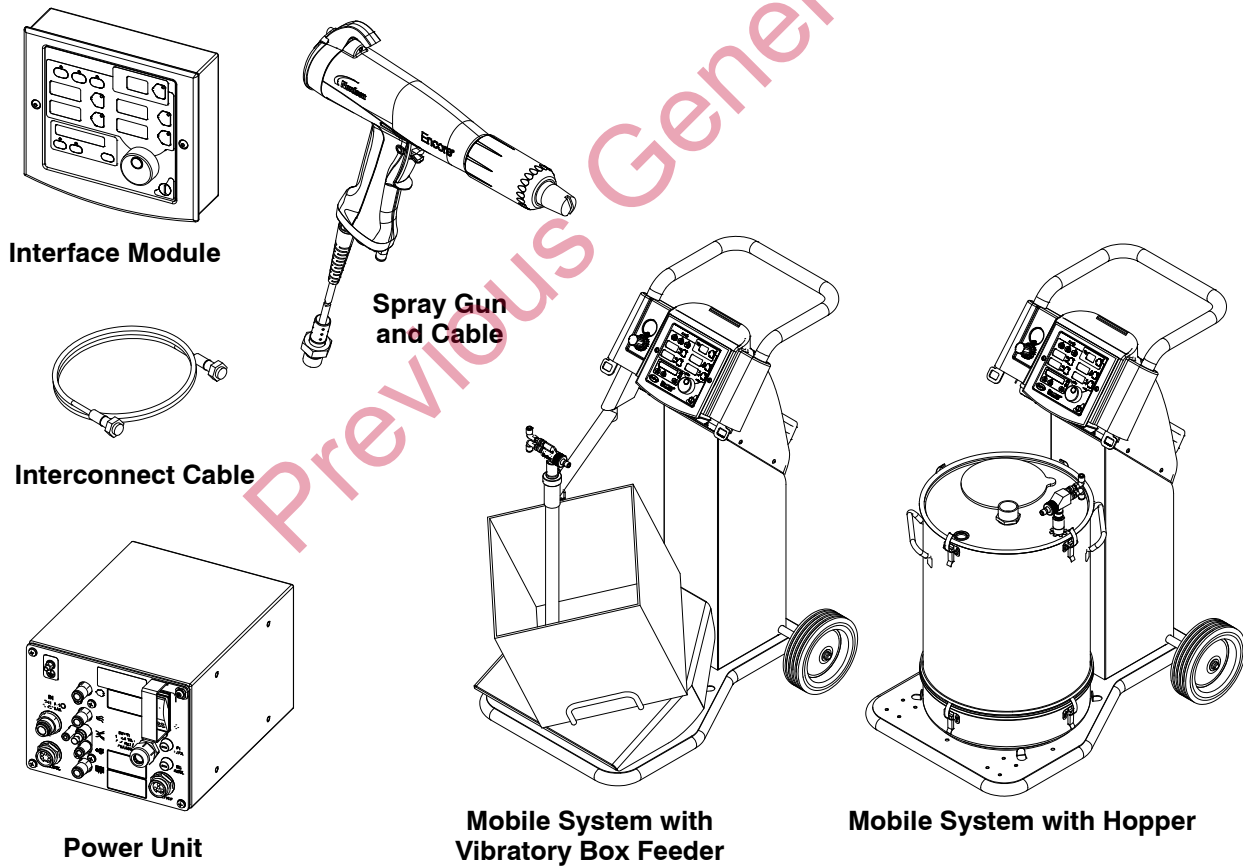

Figure 2-1 Encore XT Mobile Manual Powder Systems – Main Components

Mobile System Components

Mobile systems include:

- Encore XT manual controller
- Encore XT manual spray gun
- Encore Generation II powder feed pump
- Encore pump pickup tube
- One of the following, based on system version:
 - Vibratory table and motor – fluidizes a 25- or 50-lb (11.3- or 22.7-kg) box of powder
 - 50-lb (22.7 kg) Encore round feed hopper – fluidizes powder with low-pressure compressed air
- 11-mm powder hose, air tubing, spiral wrap, Velcro straps

The components are mounted on a sturdy two-wheeled dolly.

Rail-Mount System Components

Rail-mount systems include:

- Encore XT manual controller
- Encore XT manual spray gun
- Encore Generation II powder feed pump
- Pump adapter kit and coupling for use on HR/NHR feed hoppers
- Rail-mount bracket kit
- Grounding kit
- 11-mm powder hose, air tubing, spiral wrap, Velcro straps
- Air filter kit

NOTE: Powder can be also be supplied from an Encore in-line pump mounted in a feed center.

Wall-Mount System Components

Wall-mount systems include a

- Encore XT manual controller
- Encore XT manual spray gun
- Encore Generation II powder feed pump
- Pump adapter kit and coupling for use on HR/NHR feed hoppers
- Wall-mount bracket kit
- Grounding kit
- 11-mm powder hose, air tubing, spiral wrap, Velcro straps
- Air filter kit

NOTE: Powder can be also be supplied from an Encore in-line pump mounted in a feed center.

Specifications

Model	Input Rating	Output Rating
ENCORE Applicator	+/- 19 VAC, 1 A	100 KV, 100 μ A
ENCORE Interface Control Unit	24 VDC, 2.75 A	+/- 19 VAC, 1A
ENCORE Controller Power Unit	100–240 VAC, 50/60 Hz, 85 VA	24 VDC, 2.75 A
Vibratory Motor 50 Hz	230 VAC, +/- 10%	NA
Vibratory Motor 60 Hz	115 VAC, +/- 10%	NA

- Input Air: 6.0–7.6 bar (87–110 psi), <5 μ particulates, dew point <10 °C (50 °F)
- Max Relative Humidity: 95% non-Condensing
- Ambient Temperature Rating: +15 to +40 °C (59–104 °F)
- Hazardous Location Rating for Applicator: Zone 21 or Class II, Division 1
- Hazardous Location Rating for Controls: Zone 22 or Class II, Division 2
- Dust Ingress Protection: IP6X
- Vibrator Table Capacity: 25 kg (50 lb) box of powder
- Hopper Capacity: 11.3 or 22.7 kg (25 or 50 lb)

Mobile System with VBF

Height: 1078 mm (42.5 in.)
 Wheel Base: 620 (24.4) L x 511.5 (20.1) W
 Weight: 50.8 kg (112 lbs)

Mobile System with 50 lb. Feed Hopper

Height: 1078 mm (42.5 in.)
 Wheel Base: 620 (24.4) L x 511.5 (20.1) W
 Weight: 54.4 kg (120 lbs)

Mobile System with 25 lb. Feed Hopper

Height: 1078 mm (42.5 in.)
 Wheel Base: 620 (24.4) L x 511.5 (20.1) W
 Weight: 53 kg (117 lbs)

Equipment Labels

Applicator Certification Label

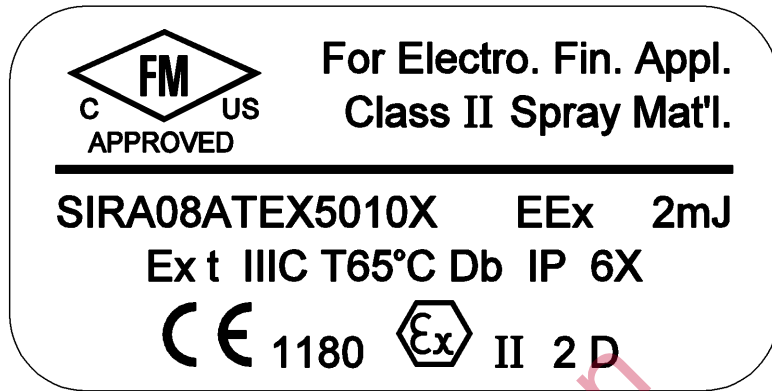

Power Unit and Gun Interface Controllers Certification Label

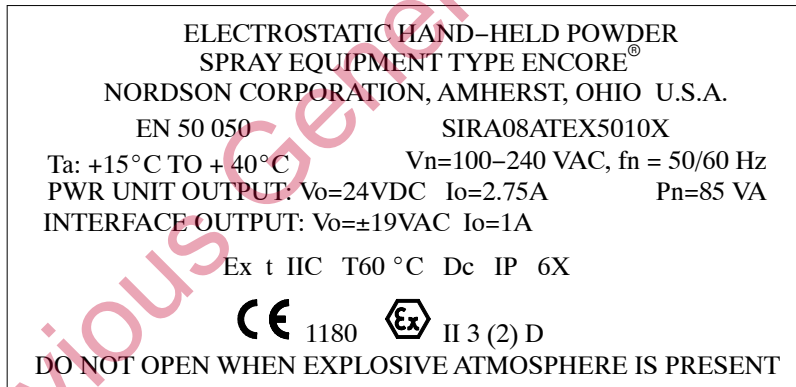

Section 3

System Setup

Wall/Rail Mount Systems

Controller Wall Mount

See Figure 3-1. Using the supplied brackets, the power unit can be oriented to the mounting bracket in 90 degree increments, as desired. Fasteners shown are provided with the controller. Make sure to provide clearance for the connections to both the power unit and the interface module.

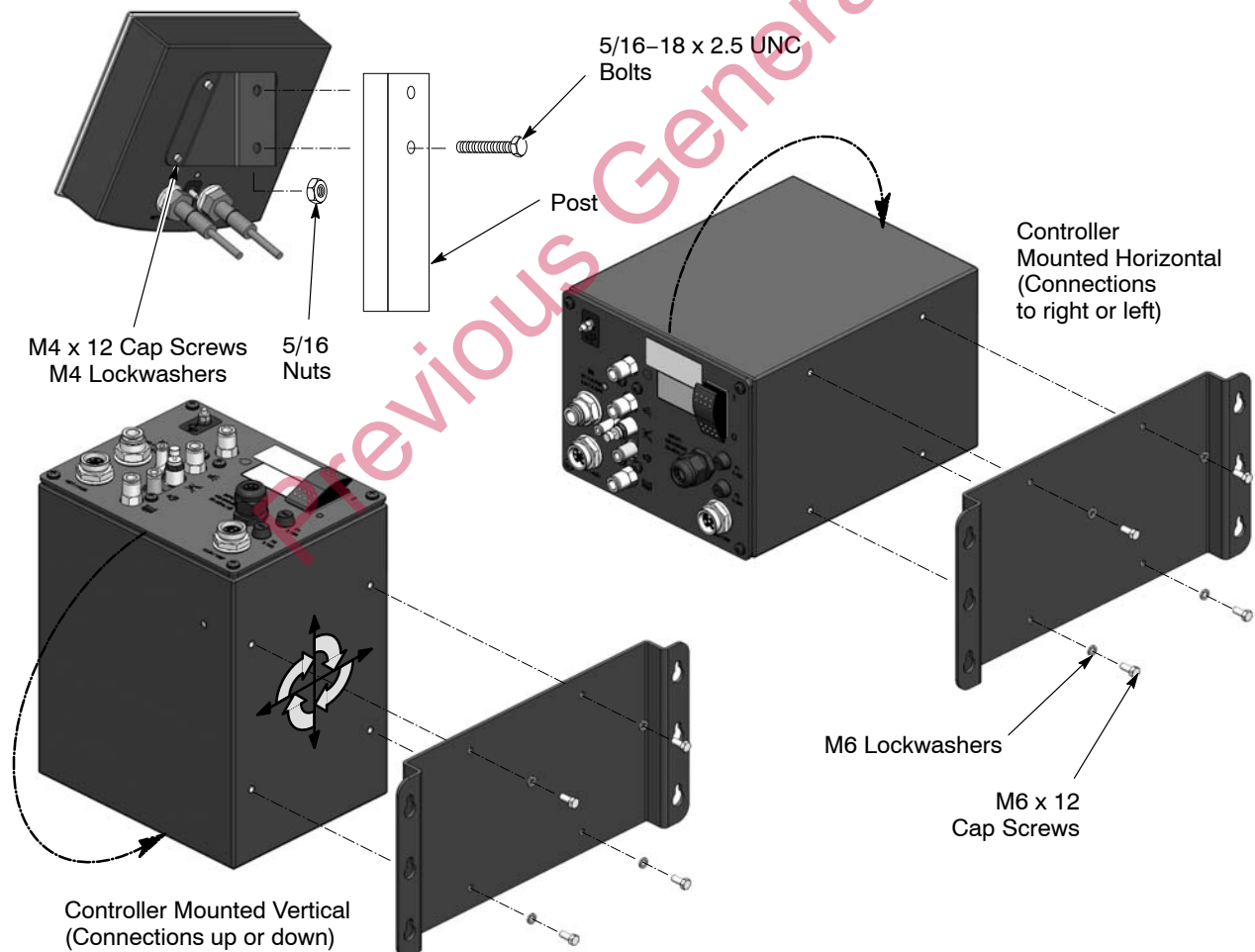

Figure 3-1 Controller Wall Mounting Brackets

Controller Rail Mount

See Figure 3-2. Using the supplied brackets, the power unit can be oriented to the mounting bracket in 90 degree increments, as desired. Fasteners shown are provided with the controller or the rail mount kit. Make sure to provide clearance for the connections to both the power unit and the interface module.

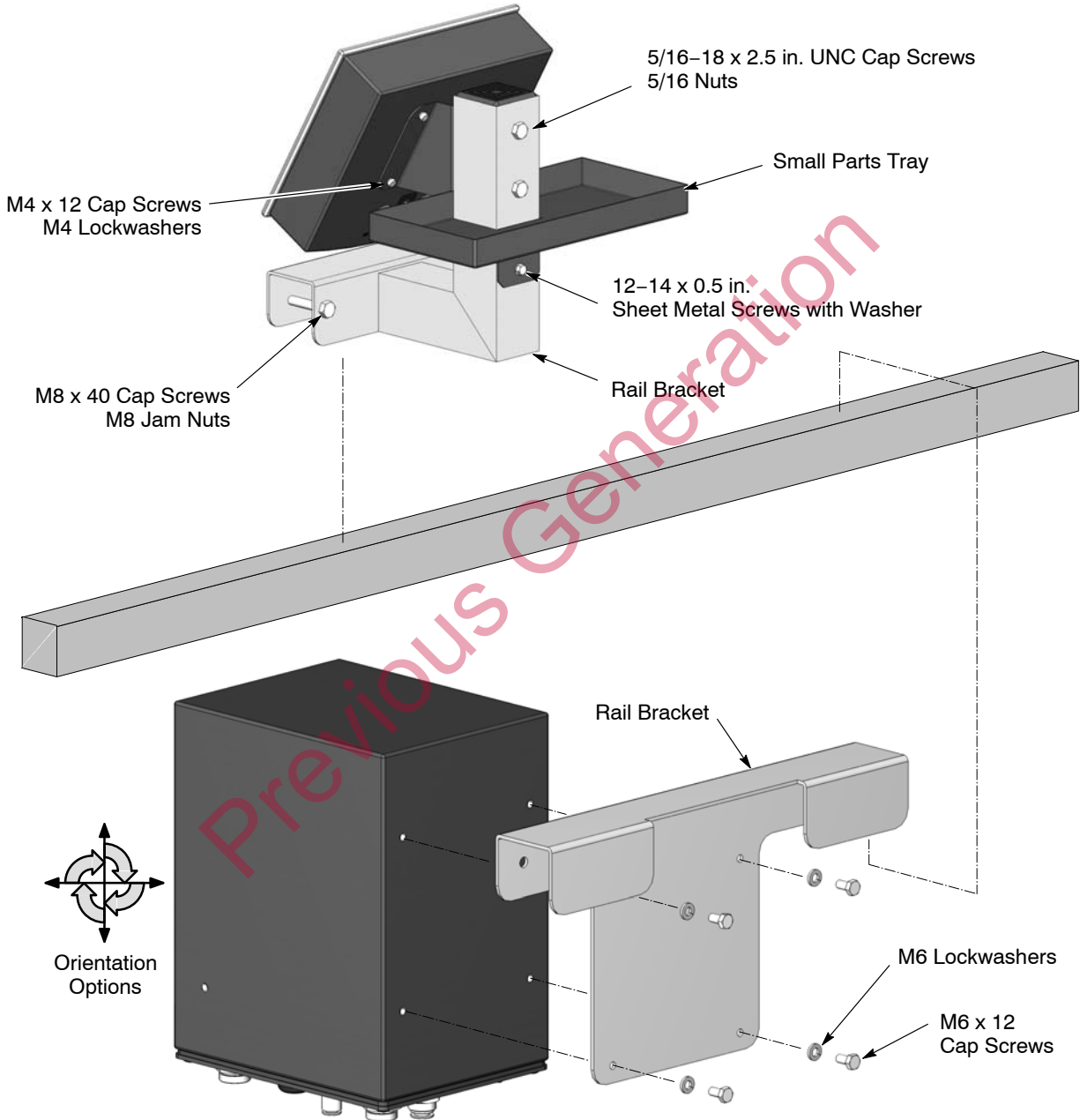
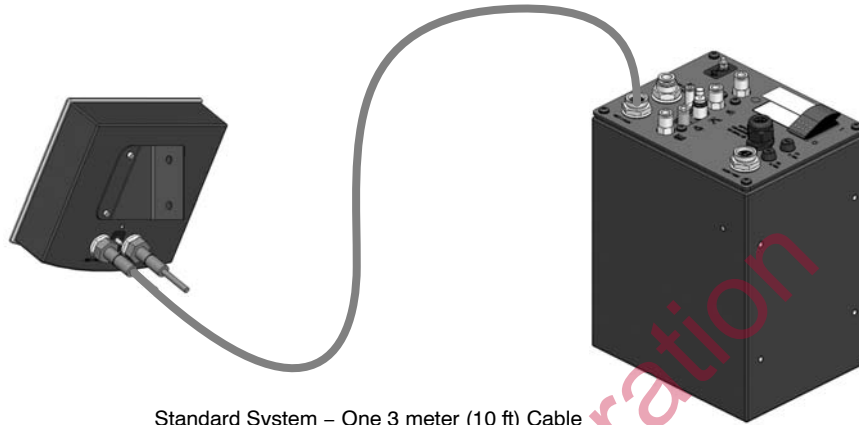

Figure 3-2 Controller Rail Mounting Brackets

Interconnect Cable Connection

Connect the gray, 3 meter (10 ft) interconnect cable to the Net/Auxiliary receptacles on the interface module and power unit.

NOTE: The interconnect cable shipped with the system is 3 meters (10 ft) long. If a longer length is desired, you must order additional cables. Two or more cables can be connected as needed.



Standard System – One 3 meter (10 ft) Cable

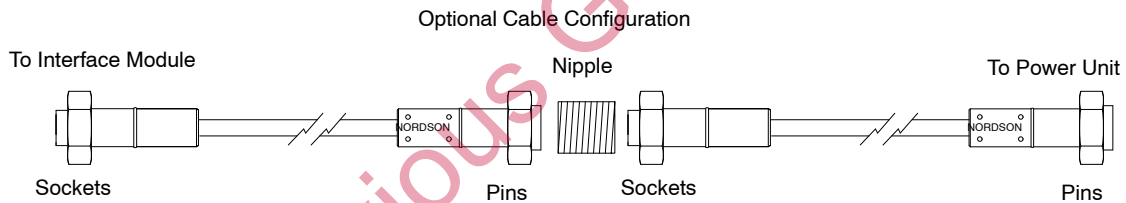

Figure 3-3 Controller Interconnect Cable Connections

Controller Connections

The Encore Spray Gun Controller is a two piece unit, consisting of a interface module and a power unit, connected by a network/power cable.

The **power unit** houses a 24Vdc power supply, circuit board, and iFlow® air control manifold.

The **interface module** houses the controller interface panel, which contains the displays and controls used to make controller function settings and spray settings.

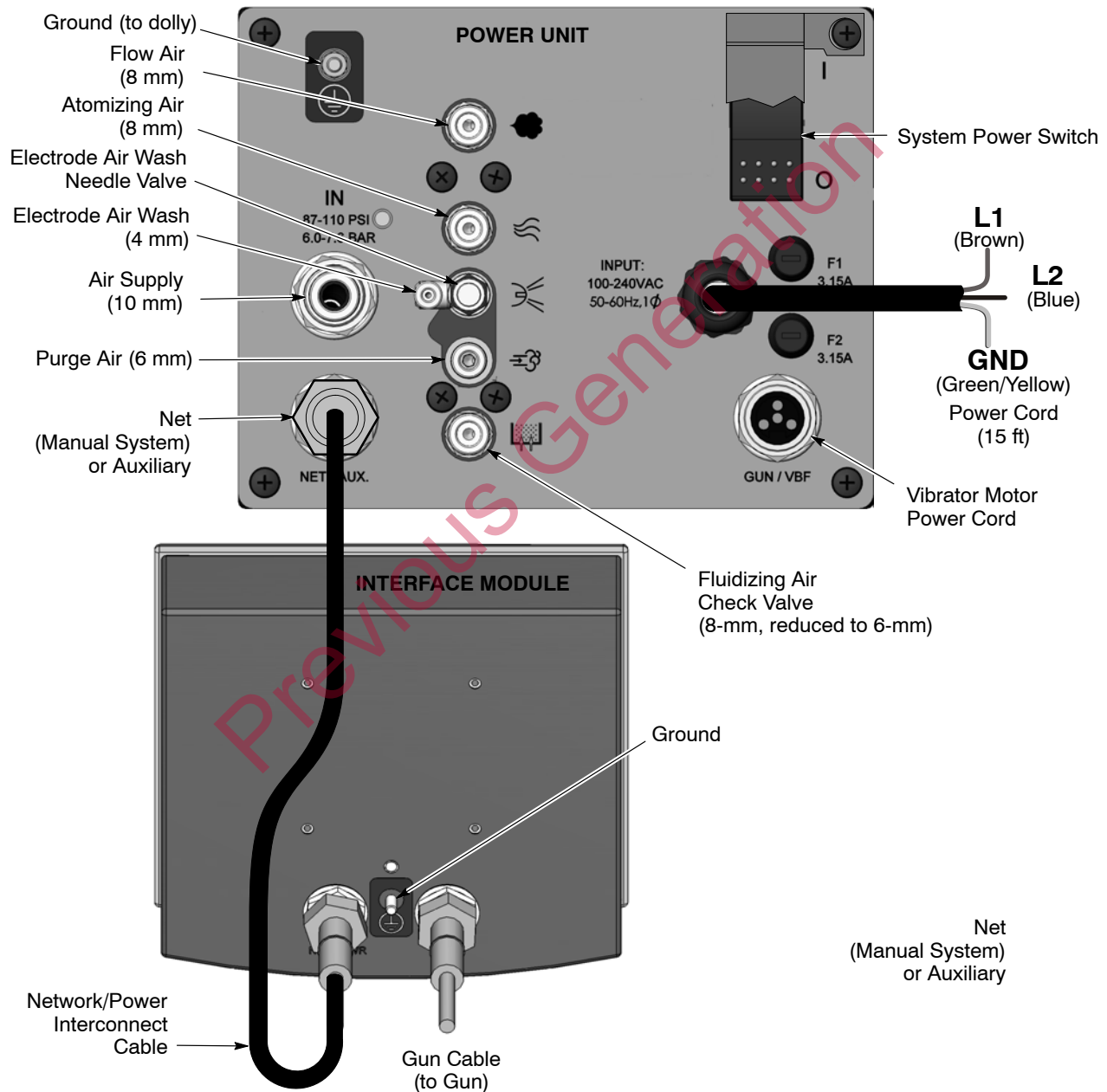

Figure 3-5 Encore XT Controller Connections

VBF System Setup

Pickup Tube and Pump Installation

1. See Figure 3-6. Unpack the pickup tube (3).
2. Swing the pickup tube arm (1) out over the vibrator table, move the pickup tube catch (2) out of the way, then slide the pickup tube through the tube holder (1A).
3. Install the pump (5) into the pump adapter (3A) with a slight twisting motion.
4. Connect air tubing as follows:
 - 8-mm blue atomizing air tubing (7) into the top tube fitting on the pump,
 - 8-mm black flow air tubing (8) into the bottom tube fitting on the pump
 - 6-mm black fluidizing air tubing (4) into the tube fitting on the pick-up tube.

NOTE: The pump is equipped with quick-connect couplings (6). Pull back on the knurled coupling rings to uncouple them.

5. Connect one end of the powder hose (9) to the pump.



WARNING: The black fluidizing air tubing, the pickup tube connector, and bulkhead union inside the dolly tower are conductive and provide a ground path from the pickup tube to the dolly. **Do not replace these components with non-conductive components.** Refer to *Parts* for replacement tubing.

NOTE: An optional dual pickup tube bracket is available. Refer to *Options* in the *Parts* section.

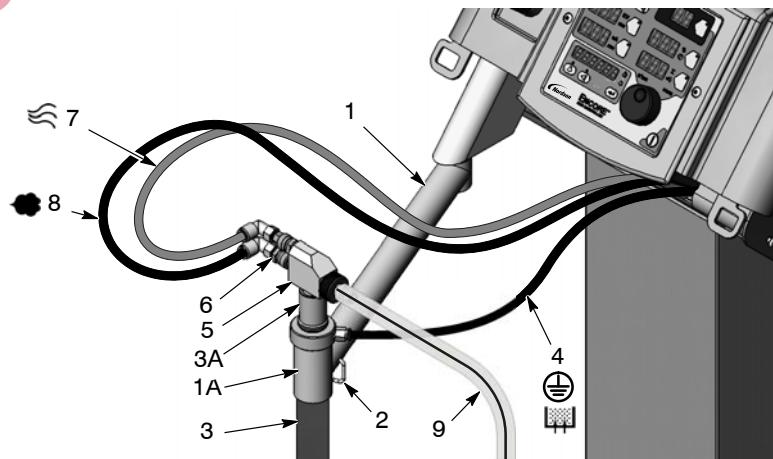

Figure 3-6 VBF System – Pickup Tube and Pump Installation

- | | | |
|-------------------------|--|-----------------------------------|
| 1. Pickup tube arm | 3A. Pump adapter | 7. 8-mm blue atomizing air tubing |
| 1A. Tube holder | 4. 6-mm conductive black fluidizing air tubing | 8. 8-mm black flow air tubing |
| 2. Pickup tube catch | 5. Powder pump | 9. Powder hose |
| 3. Pickup tube assembly | 6. Quick-connect fittings | |

Hopper and Wall/Rail Mount System Setup

Hopper Installation – Mobile Systems

1. See Figure 3-7. Unclamp the hopper lid and remove the vent hose and hose clamps.
2. Place the hopper on the dolly platform so that the bottom of the fluidizing pan fits into the cutout in the dolly platform.
3. Connect the 10-mm stem x 6-mm tube reducer to the 10-mm elbow fitting on the fluidizing pan.
4. Connect the 6-mm blue fluidizing air tubing to the reducer.
5. Connect the ring-tong terminal on the 1-ft green/yellow ground cable shipped with the system to the ground stud on the side of the fluidizing pan, then plug the cable into the grounding socket on the dolly base.
6. Install the hose clamp over the end of the vent hose and connect the hose to the vent stack on the lid. Tighten the clamp to secure the hose.

NOTE: Before turning on the controller interface, route the other end of the vent hose to a vent stub on a color module or into the spray booth. This prevents the very fine powder particles in the vented fluidizing air from contaminating the spray room.

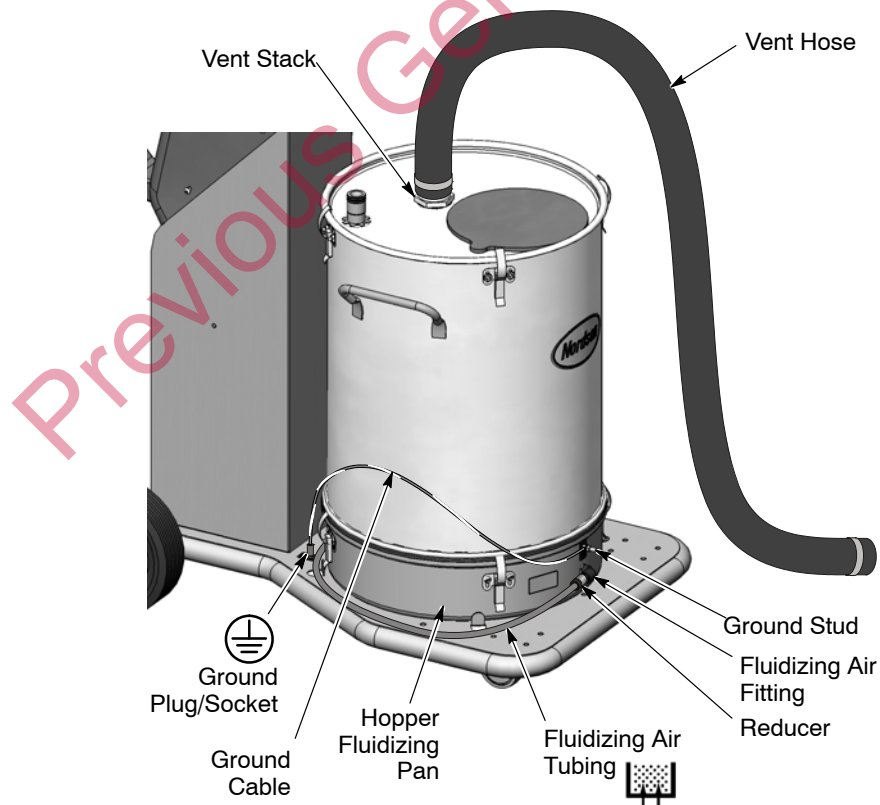

Figure 3-7 Hopper Installation on Mobile System dolly

Wall/Rail Mount System Hopper Installation

If connecting fluidizing air to a Nordson feed hopper, use the 10-mm stem x 8-mm tube reducer fitting shipped with the controller to connect the 8-mm tubing supplied with the system to the hopper fluidizing air fitting.

Install a customer-supplied air regulator and gauge in the air line between the power unit and the powder source to regulate the fluidizing air pressure.

Connect the vent hose shipped with the hopper to the hopper lid as shown in Figure 3-7. Route the vent hose to a vent stub on the booth or collector module.

Pump Mounting – Feed Hoppers



CAUTION: Pump adapter O-rings are conductive silicone, to provide a ground connection between the pump body and the pickup tube or hopper lid. Do not replace these O-rings with non-conductive O-rings.

Hopper and wall/rail mount systems include an Encore pump adapter kit and a coupling, either of which can be used to install the Encore pump on the pickup tube provided with a Nordson HR or NHR feed hopper. It is recommended that the adapter be used rather than the coupling.

Adapter Installation

Follow these steps to install the Encore pump adapter:

1. See Figure 3-8. Remove the pickup tube from the pump mount in the hopper lid, then unscrew the existing adapter from the pickup tube.
2. Screw the Encore pump adapter shipped with the system on the pickup tube.
3. Install the pump adapter and pickup tube into the pump mount, then install the Encore pump into the adapter with a slight twisting motion.

Coupling Installation

See Figure 3-8. The coupling allows you to use the existing pump adapter. Install the pump coupling on the existing pump mount with a slight twisting motion, then install the pump into the coupling with the same motion.

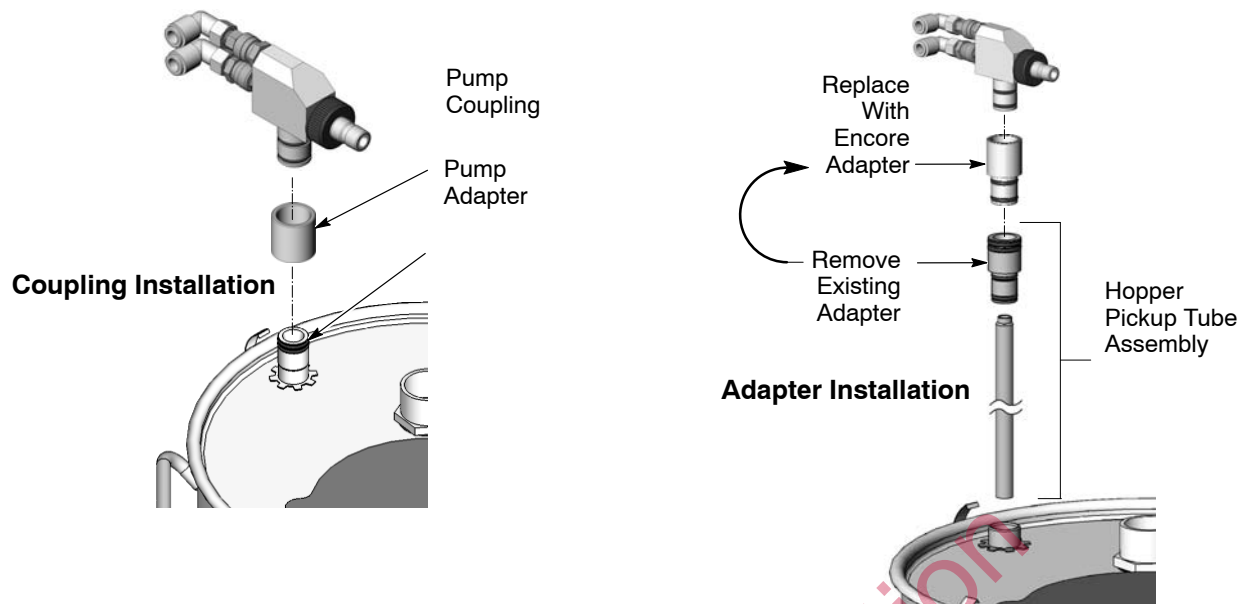

Figure 3-8 Pump Mounting with Adapter Kit or Coupling on HR or NHR Hoppers

Pump Connections

1. See Figure 3-9. Plug the 8-mm blue atomizing air and 8-mm black flow air tubing into the pump tube fittings as shown.
2. Push the 11-mm antistatic powder hose onto the barbed throat holder.

NOTE: The pump is equipped with quick-connect couplings that allow you to quickly disconnect the air tubing when cleaning or repairing the pump. Pull back on the knurled coupling rings to disconnect them.

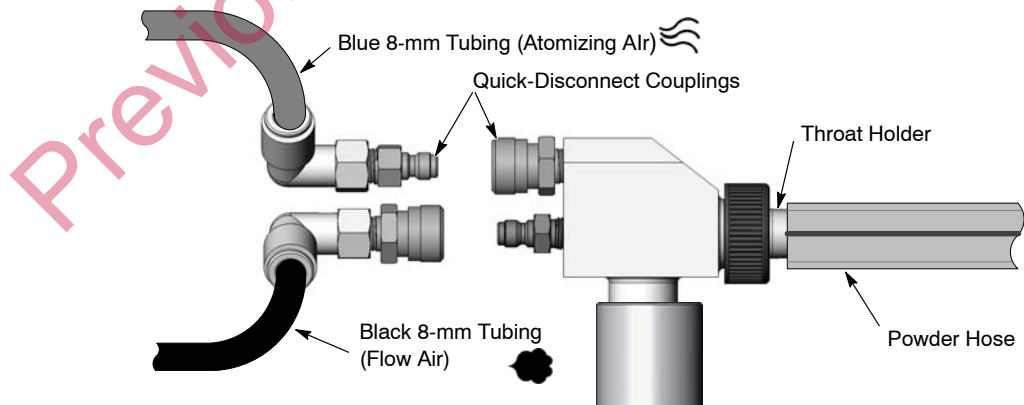

Figure 3-9 Pump Connections

Wall/Rail Mount Power Unit Connections

The following is supplied with the system:

1. Connect the 8-mm blue tubing to the atomizing air fitting on the power unit.
2. Connect the 8-mm black flow air tubing to the flow air fitting on the power unit.

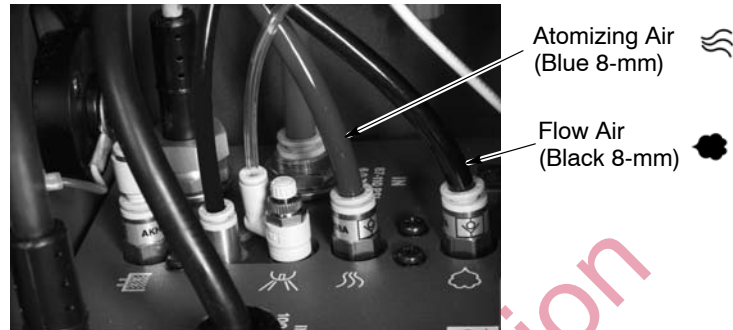

Figure 3-10 Flow and Atomizing Air Tubing Connections to Power Unit

Spray Gun Connections

Unpack the spray gun. Uncoil the spray gun cable and the included clear 4-mm and black 6-mm air tubing. Connect the gun cable and air tubing as described in the following procedures.

Gun Cable

1. Mobile System: See Figure 3-11. Feed the spray gun cable into the back of the dolly tower and up through the top front. This will allow you to bundle the cable with the purge and electrode air wash tubing.
2. Connect the cable to the interface module receptacle labeled GUN. The cable plug and receptacle are keyed.
3. Thread the cable nut onto the receptacle and tighten the nut securely.

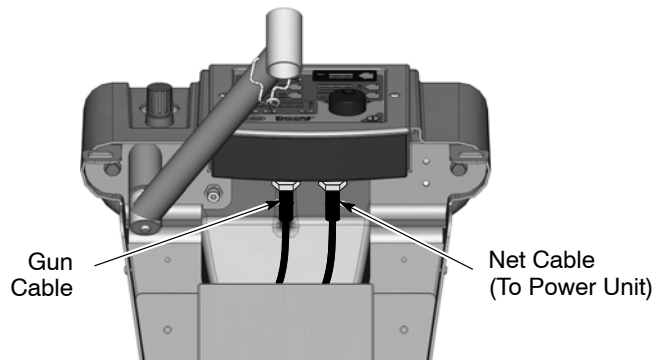

Figure 3-11 Gun Cable Connection to Interface Module – Mobile Systems

Air Tubing and Powder Hose

See Figure 3-12.

1. Connect the 6-mm black purge air tubing to the quick-disconnect fitting in the gun handle. Connect the other end to the Purge Air fitting on the power unit.
2. Connect the 4-mm clear electrode air wash tubing to the barbed fitting in the gun handle. Connect the other end to the Gun Air fitting on the power unit.
3. Push the barbed hose adapter into the end of the powder hose, then plug the adapter into the powder inlet tube in the bottom of the spray gun handle.

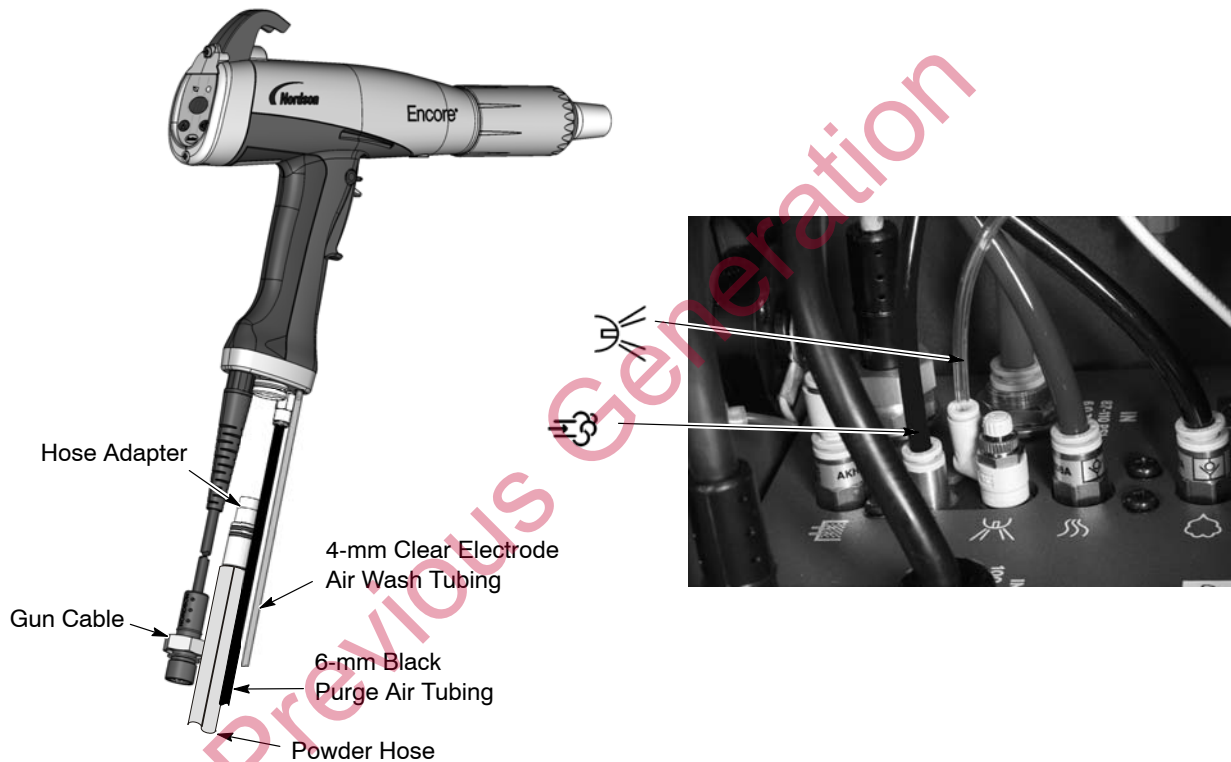

Figure 3-12 Gun Connections

Bundling Tubing and Cable

Use the sections of black spiral wrap supplied with the system to bundle together the spray gun cable, air tubing, and powder hose.

System Air and Electrical Connections

Mobile System Air Supply

See Figure 3-13. Connect 10-mm air tubing from your compressed air supply to the system air filter in the power unit cabinet. The air supply pressure should be 6.0–7.6 bar (87–110 psi).

An optional input air kit with connectors, couplings, and 20 ft of 10 mm tubing is available. Refer to the *Parts* section for the kit contents and ordering information.

NOTE: Compressed air should be supplied from an air drop equipped with a self-relieving shutoff valve. The air must be clean and dry. A refrigerant or desiccant-type air drier and air filters are recommended.

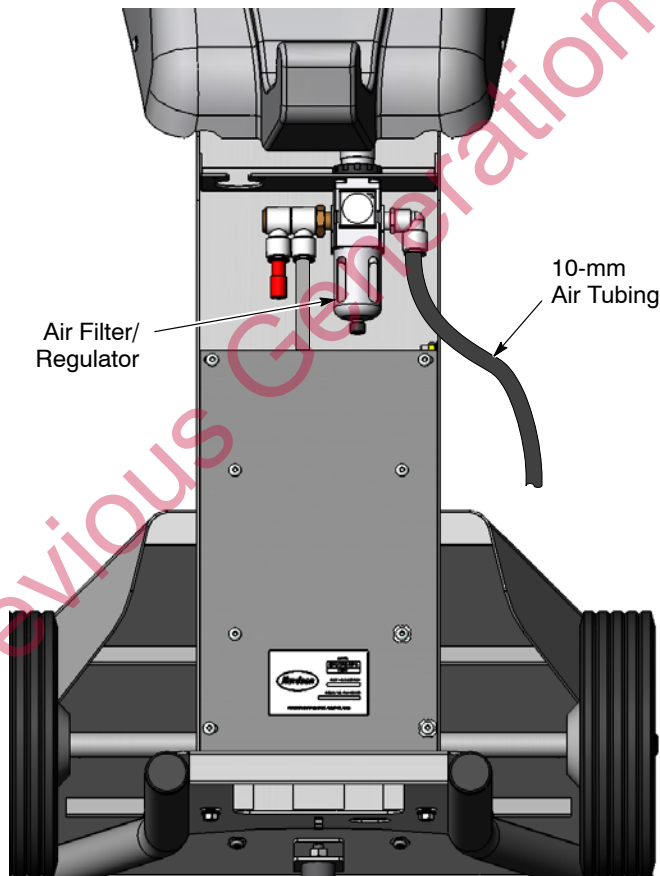

Figure 3-13 System Air Supply Connection

Wall / Rail Mount System Air Supply

A filter/regulator, 6 meters (20 ft) of 10-mm blue air tubing, and a 10-mm plug is supplied with the system. Mount the filter/regulator in a convenient location where it can be checked and serviced.

See Figure 3-14. Connect a length of the blue 10-mm air tubing supplied with the system from your compressed air supply to the filter/regulator inlet. The air supply pressure should be 6.0–7.6 bar (87–110 psi).

Connect another length of the 10-mm air tubing from the dual outlet port of the filter/regulator to the input fitting on the power unit. Plug the unused port of the dual output fitting.

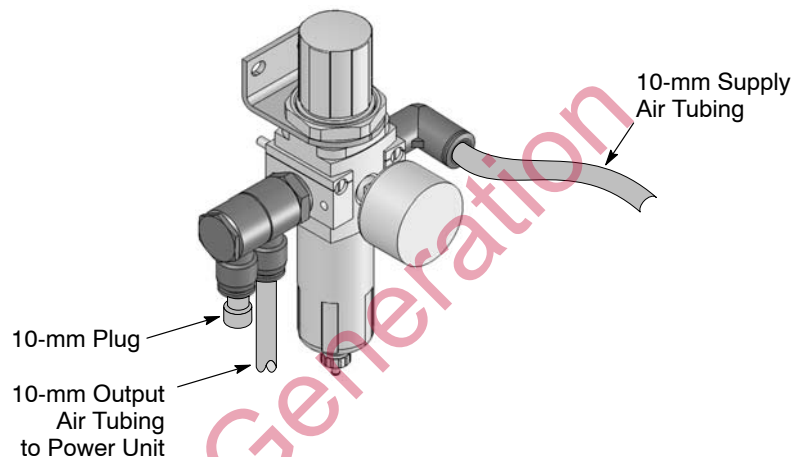

Figure 3-14 Wall / Rail Mount System Air Supply Connection

Electrical Connections



CAUTION: If you are setting up a Vibratory Box Feeder system, check the system identification plate for the correct voltage. Connecting a system with a 115 Vac vibrator motor to 230 Vac could damage the vibrator motor.

NOTE: The spray gun controller is rated for 100–240 Vac at 50/60 Hz, single phase, and is marked as such, but the power supplied to the system must match the vibrator motor rating.

Wire the system power cord to a customer-supplied three-prong plug. Connect the plug to a receptacle that will supply the system with the correct voltage.

Wire Color	Function
Blue	N (neutral)
Brown	L (hot)
Green/Yellow	GND (ground)

System Ground



WARNING: All conductive system components in the spray area must be connected to a true earth ground. Failure to observe this warning could result in an electrostatic discharge strong enough to cause a fire or explosion.

Mobile Systems

See Figure 3-15. Connect the ground cable attached to the power unit ground stud to a true earth ground.

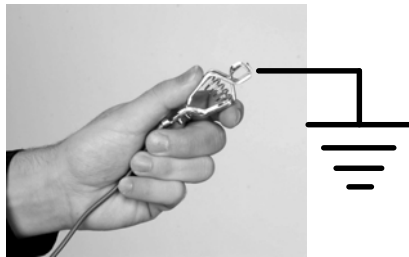

Figure 3-15 System Ground Connection

Wall / Rail Mount Systems

Use the ESD ground bus bar kit included with the system to connect the power unit ground stud to the grounded spray booth or a true earth ground. Refer to the instructions included with the kit.

Section 4

Operation



WARNING: Allow only qualified personnel to perform the following tasks. Follow the safety instructions in this document and all other related documentation.



WARNING: This equipment can be dangerous unless it is used accordance with the rules laid down in this manual.



WARNING: All electrically conductive equipment in the spray area must be grounded. Ungrounded or poorly grounded equipment can store an electrostatic charge which can give personnel a severe shock or arc and cause a fire or explosion.

European Union, ATEX, Special Conditions for Safe Use

1. The Encore XT Manual Applicator shall only be used with the associated Encore XT Interface Control Unit and Encore XT Controller Power Unit, over the ambient temperature range of +15 °C to +40 °C.
2. Equipment may only be used in areas of low impact risk.
3. Caution should be taken when cleaning plastic surfaces of the Encore XT controller and Interface. There is a potential for static electricity build up on these components.

VBF Powder Box Installation

NOTE: The vibrator table can hold a maximum 25 kg (50 lb) box of powder.

1. See Figure 4-1. Lift the pickup tube up and swing the tube catch down and under the pickup tube end to hold it in place on the arm.

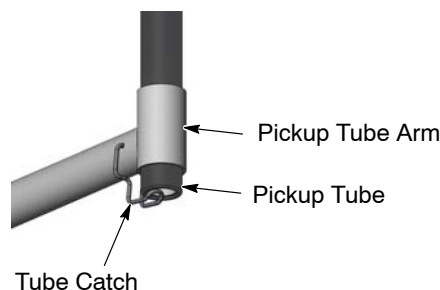

Figure 4-1 Pickup Tube Bracket Use

VBF Powder Box Installation *(contd)*

2. See Figure 4-2. Place a box of powder on the vibrator table.
3. Fold back the box flaps and open the plastic bag containing the powder coating. Fold the bag over the box flaps to keep the flaps out of the way.

NOTE: Do not force the end of the pickup tube into the powder. Vibration and gravity will cause the pickup tube to sink into the powder.

4. Swing the pickup tube catch out from under the pickup tube and slide the tube down into the powder.
5. To prevent accidental powder spills, wrap the plastic bag around the pickup tube and loosely secure the bag with a tie wrap.

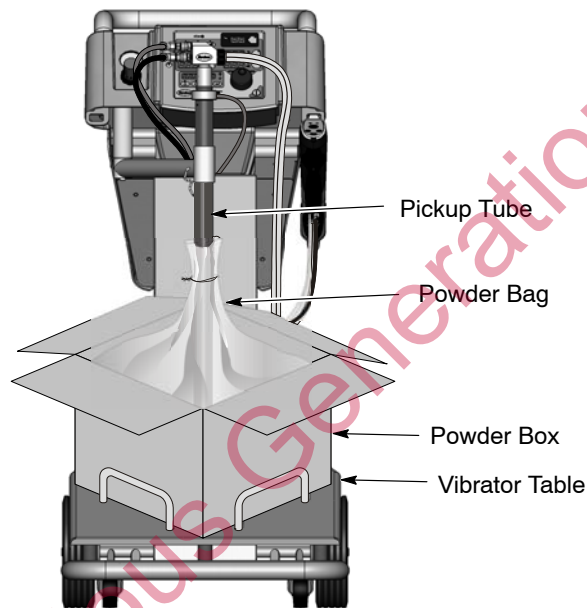

Figure 4-2 Powder Box Installation

Feed Hopper Filling

Remove the rubber plug from the hopper lid and fill the hopper 1/2 full of powder. Do not overfill, as the powder volume will increase when fluidizing air is turned on. Make sure the vent hose is connected to the powder booth, so that vented fine powder dust does not contaminate the spray room.

Spray Gun Operation

The spray gun interface and settings trigger allow you to change the preset or the powder flow settings, or purge the gun as needed, without using the controller Interface.

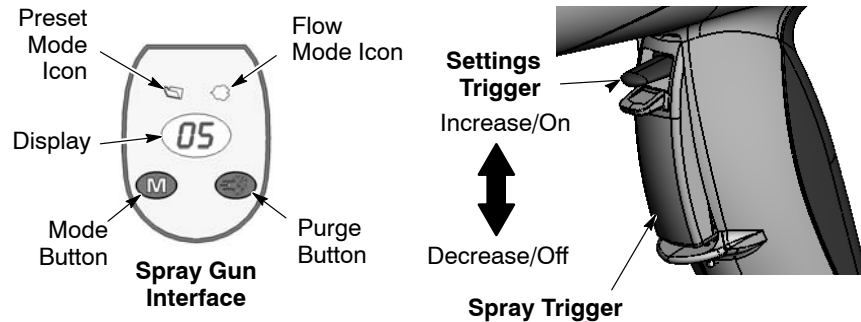

Figure 4-3 Gun Controls

Changing Presets with the Settings Trigger

1. See Figure 4-3. Release the spray trigger. Presets cannot be changed while the gun is triggered on.
2. Press the **Mode** button until the **Preset Mode** icon is lit. The display shows the current preset number.
3. Push the settings trigger up or down until the desired preset number is displayed on the spray gun interface.

NOTE: Unprogrammed preset numbers (presets where all setpoints are zero) are automatically skipped. Refer to *Presets* on page 4-13 for preset programming instructions.

4. Press the spray trigger. The system sprays with the new preset.

Changing Powder Flow with the Settings Trigger

1. See Figure 4-3. Press the **Mode** button until the **Flow Mode** icon is lit.
2. Push the settings trigger up or down to change the flow setpoint. This can be done without releasing the spray trigger.

The powder flow immediately changes. The new flow setpoint is displayed on both the spray gun interface and the controller interface.

NOTE: If using **Total Flow** mode, the total air setpoint must be greater to zero or you will not be able to set % Flow Air and the gun will not spray powder. Refer to page 4-15 for more information.

Purging the Spray Gun

1. See Figure 4-3. Point the gun into the booth and release the spray trigger.
2. Press the **Purge** button. The purge will continue as long as you press the purge button.

Purging the Spray Gun (contd)

NOTE: If the settings trigger is configured for Purge, then pressing up or down on the settings trigger purges the gun. Refer to *Controller Configuration* on page 4-20 for settings trigger configuration.

Purge the gun periodically to keep the powder path inside the spray gun clean. The purge length and frequency required will depend on the application.

NOTE: The purge air only cleans the spray gun powder path. To purge the powder hose, disconnect it from the pump and the gun, place the gun end inside the booth, and blow it out from the pump end with compressed air.

Fluidizing Air Operation

Powder Feed Hopper

If the controller is configured for a powder feed hopper, then turning on the interface power turns on fluidizing air to the hopper. Adjust the fluidizing air pressure to 0.3–0.7 bar (5–15 psi). The pressure should be just enough so the powder in the hopper “boils” gently. The fluidizing air causes the powder to increase in volume.

Fluidize the powder for 5–10 minutes to make sure it is evenly fluidized and no clumps are left before spraying.

Vibratory Box Feeder

If the controller is configured for a vibratory box feeder, then the fluidizing air is turned on and off when the spray gun is triggered on and off.

Adjust the fluidizing air pressure to 0.3–0.7 bar (5–10 psi). The pressure should just fluidize the powder around the pickup tube. The powder should not boil violently or fountain out of the box.

When the spray gun is triggered off, the vibrator motor remains on for a configurable delay. This delay prevents rapid on/off motor cycling every time you trigger the gun off and on and prolongs the life of the motor. The default delay time is 30 seconds.

The vibrator motor can also be set to continuous operation. If set this way, press and release the spray gun trigger to start the motor. To turn off the motor, set the interface to Standby or turn off controller power.

To configure the system for a vibratory box feeder, change the VBF delay time, or set the vibrator motor to continuous operation, refer to *Controller Configuration* on page 4-20.

Electrode Air Wash Operation

Electrode air wash air continually washes the spray gun electrode to prevent powder from collecting on it. Electrode air wash air turns on and off automatically when the spray gun is triggered on and off.

The air flow needle valve on the power unit is set at the factory for the most common applications ($1\frac{1}{2}$ turns CCW from fully closed position), but can be adjusted if needed.

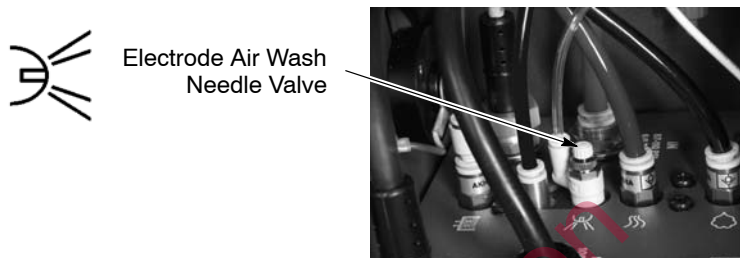

Figure 4-4 Electrode Air Wash Valve Location

Daily Operation



WARNING: All conductive equipment in the spray area must be connected to a true earth ground. Failure to observe this warning may result in a severe shock.

NOTE: The controller is shipped with a default configuration that will allow you to start spraying powder as soon as you finish setting up the system. Refer to *Controller Configuration* on page 4-20 for a list of the defaults and instructions on how to change them, if desired.

Initial Startup

With the fluidizing and flow air set to zero, and no parts in front of the gun, trigger the gun and record the μA output. Monitor the μA output daily, under the same conditions. A significant increase in μA output indicates a probable short in the gun resistor. A significant decrease indicates a resistor or voltage multiplier requiring service.

Startup

1. Turn on the spray booth exhaust fan.
2. Turn on the system air supply.
3. Install a box of powder or a hopper filled with powder on the cart. Refer to *Powder Box Installation* on page 4-1 for instructions.
4. See Figure 4-5. Make sure the spray gun is not triggered, then turn on controller power. The displays and icons on the controller interface and gun interface should light.

Startup (contd)

Figure 4-5 System Controls – Mobile System Shown

Feed hoppers: Turning on the controller power turns on the fluidizing air. Adjust the fluidizing air pressure to 0.3–0.7 bar (5–15 psi). The pressure should be just enough so the powder in the hopper “boils” gently. Fluidize the powder for 5–10 minutes before spraying powder.

5. Point the spray gun into the booth and press the spray trigger to start spraying powder.

Vibratory box feeders: Adjust the fluidizing air so that the powder around the pickup tube is being fluidized without blowing powder out of the box. Triggering the spray gun turns on the vibrator motor. Depending on the vibrator motor function setting, the motor will:

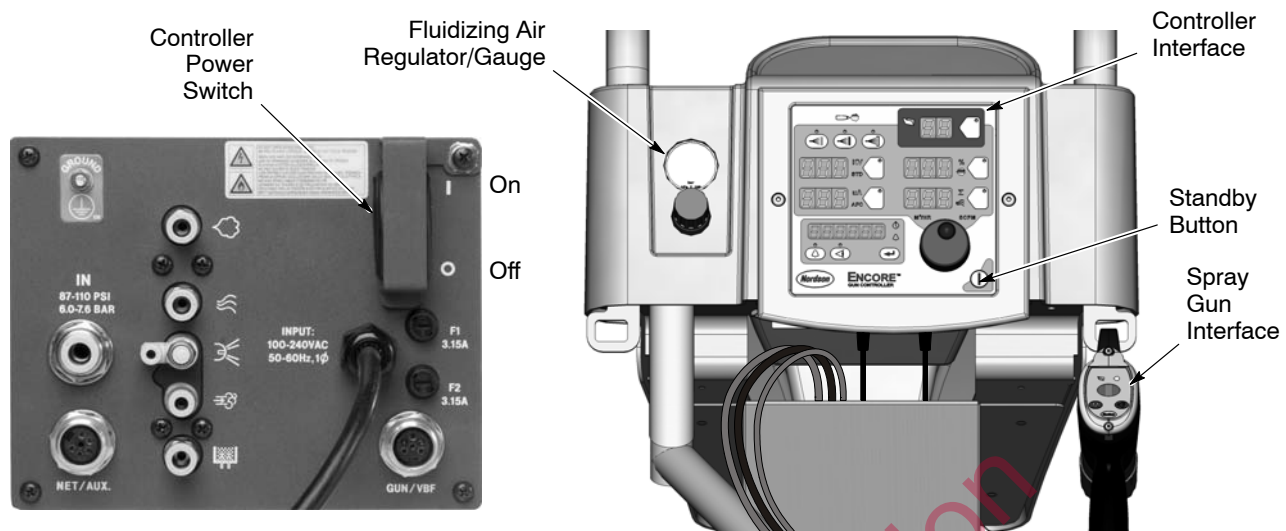
- turn off after a delay when the trigger is released, or
- continue to operate until the Standby button is pressed or controller power is turned off.

Refer to *Controller Configuration* on page 4-20 to change the motor function setting.

6. Select the desired preset and start production. Refer to *Presets* on page 4-13 for preset programming instructions.

The controller interface displays actual output when the gun is spraying and the current preset setpoints when the gun is off.

NOTE: If using **Total Flow** mode, the total air setpoint must be greater to zero or you will not be able to set % Flow Air and the gun will not spray powder. Refer to page 4-15 for more information.

Standby Button

Use the **Standby** button shown in Figure 4-5 to shut off the interface and disable the spray gun during breaks in production. When the controller interface is off the spray gun cannot be triggered, and the spray gun interface is disabled.

To shut off controller power, use the power switch on the power unit.

Factory Set Presets

Presets are programmed electrostatic and powder flow setpoints for a particular part or application. Up to 20 presets can be programmed. The system is shipped with Presets 1–3 already programmed. Refer to *Presets* on page 4-13 for programming instructions.

Preset	Electrostatics, Powder Flow	kV	μ A	%	Σ
1	Max kV, 150 g/min (20 lb/hr)	100	30	45	3.0
2	Max kV, 300 g/min (40 lb/hr)	100	30	75	3.0
3	Select Charge 3 (deep recess), 150 g/min (20 lb/hr)	100*	60*	45	3.0

* Select Charge Mode settings are factory set and cannot be changed.

Changing Flat Spray Nozzles



WARNING: Release the spray gun trigger, turn off the interface, and ground the electrode before performing this procedure. Failure to observe this warning could result in a severe electrical shock.

1. Purge the spray gun and turn off the interface to prevent accidentally triggering the gun on.
2. Unscrew the nozzle nut counterclockwise.
3. Pull the flat spray nozzle off the electrode assembly.

NOTE: Re-install the electrode if it comes out of the powder outlet tube.

4. Install a new nozzle on the electrode assembly. The nozzle is keyed to the electrode assembly. Do not bend the antenna wire.
5. Screw the nozzle nut onto the gun body clockwise until finger-tight.

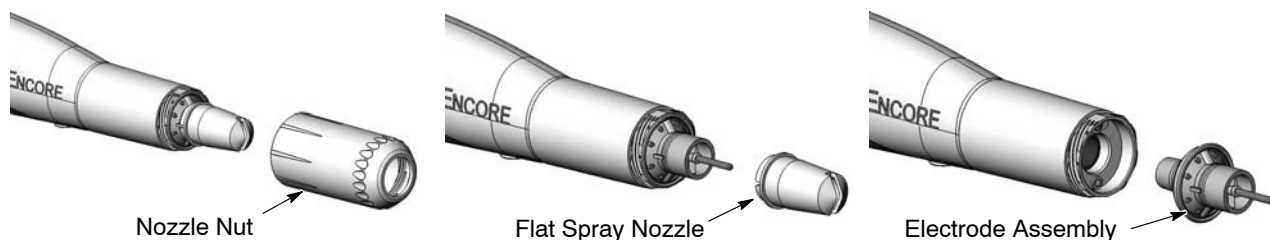

Figure 4-6 Changing a Flat Spray Nozzle

Changing Deflectors or Conical Nozzles



WARNING: Release the spray gun trigger, turn off the interface, and ground the electrode before performing this procedure. Failure to observe this warning could result in a severe electrical shock.

1. Purge the spray gun and turn off the interface to prevent accidentally triggering the gun on.
2. Gently pull the deflector off the electrode holder. If only changing the deflector, install the new one on the electrode holder, being careful not to bend the electrode wire.
3. To change the entire nozzle, unscrew the nozzle nut counterclockwise.
4. Pull the conical nozzle off the electrode assembly.

NOTE: If the electrode assembly comes out of the powder outlet tube, re-install it.

5. Install a new conical nozzle on the electrode assembly. The nozzle is keyed to the electrode assembly.
6. Screw the nozzle nut onto the gun body clockwise until finger-tight.
7. Install a new deflector on the electrode assembly. Do not bend the electrode wire.

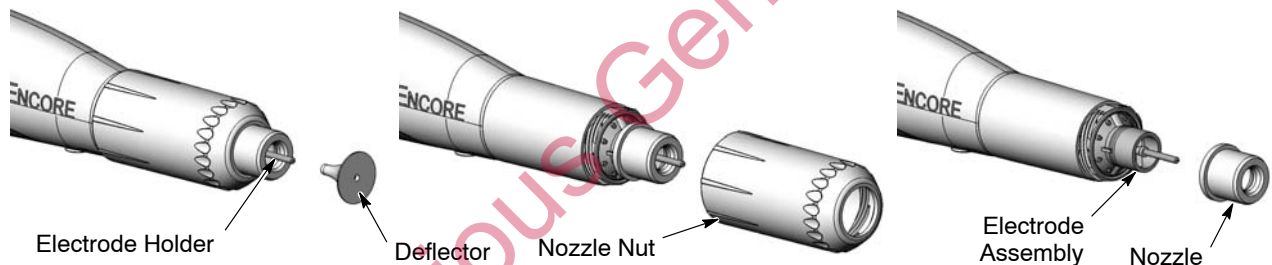

Figure 4-7 Changing a Conical Nozzle

Installing the Optional Pattern Adjuster Kit

An optional pattern adjuster kit with integral conical nozzle can be installed in place of a standard flat spray or conical nozzle.

NOTE: Deflectors are not included with the pattern adjuster kit; they must be ordered separately. The 38-mm deflector cannot be used with the kit.

1. Remove the deflector, nozzle nut, and conical nozzle, or the nozzle nut and flat spray nozzle.
2. Blow off the electrode assembly.
3. Install the integral conical nozzle onto the electrode assembly and screw the nozzle nut clockwise until finger-tight.
4. Install a 16, 19, or 26-mm deflector onto the electrode holder.

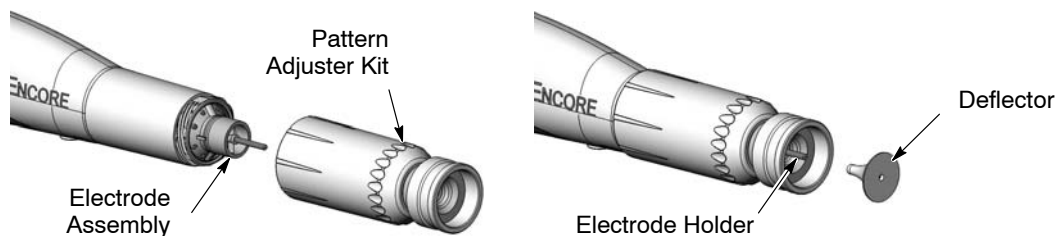

Figure 4-8 Pattern Adjuster Kit Installation

Shutdown

1. Purge the spray gun by pressing the Purge button until no more powder is blown from the gun.
2. Press the standby button to turn off the spray gun and interface.
3. Turn off the system air supply and relieve the system air pressure.
4. If shutting down for the night or a longer period of time, move the power unit switch to the OFF position to shut off system power.
5. Perform the *Daily Maintenance* procedures on page 4-10.

Maintenance



WARNING: Allow only qualified personnel to perform the following tasks. Follow the safety instructions in this document and all other related documentation.



WARNING: Before performing the following tasks, turn off the controller and disconnect system power. Relieve system air pressure and disconnect the system from its input air supply. Failure to observe this warning may result in personal injury.

Recommended Cleaning Procedure for Powder Contact Parts

Nordson Corporation recommends using an ultrasonic cleaning machine and Oakite® BetaSolv emulsion cleaner to clean spray gun nozzles and powder path parts.

NOTE: Do not immerse the electrode assembly in solvent. It cannot be disassembled; cleaning solution and rinse water will remain inside the assembly.

1. Fill an ultrasonic cleaner with BetaSolv or an equivalent emulsion cleaning solution at room temperature. Do not heat the cleaning solution.
2. Remove the parts to be cleaned from the gun. Remove the O-rings. Blow off the parts with low-pressure compressed air.

NOTE: Do not allow the O-rings to come in contact with the cleaning solution.

3. Place the parts in the ultrasonic cleaner and run the cleaner until all parts are clean and free of impact fusion.
4. Rinse all parts in clean water and dry before re-assembling the spray gun. Inspect the O-rings and replace any that are damaged.

NOTE: Do not use sharp or hard tools that will scratch or gouge the smooth surfaces of powder contact parts. Scratches will cause impact fusion.

Maintenance Procedures

Component	Procedure
Spray Gun (Daily)	<ol style="list-style-type: none"> 1. Point the spray gun into the booth and purge the spray gun. 2. Shut off the system air supply and power. 3. Disconnect the powder feed hose adapter and blow out the spray gun powder path. 4. Disconnect the powder feed hose at the pump. Place the gun end of the hose inside the booth and blow out the hose from the pump end. 5. Remove the nozzle and electrode assembly and clean them with low-pressure compressed air and clean cloths. Check them for wear and replace them if necessary. 6. Blow off the gun and wipe it down with a clean cloth.
Pump (Daily)	<ol style="list-style-type: none"> 1. Disconnect the pump air hoses and remove the pump from the pickup tube. 2. Disassemble the pump and clean all parts using low-pressure compressed air. 3. Replace any worn or damaged parts. <p>Refer to the Encore Powder Pump manual 1095927 for instructions and spare parts.</p>
Controller (Daily)	Blow off the power unit and interface module with a blow gun. Wipe powder off the controller with a clean cloth.
System Air Filter (Periodically)	Check the system air filter/regulator. Drain the filter and change the filter element as needed.
System Grounds	<p>Daily: Make sure the system is securely connected to a true earth ground before spraying powder.</p> <p>Periodically: Check all system ground connections.</p>

Using the Controller Interface

Interface Components

Use the controller interface to make preset settings, view help codes, monitor system operation, and configure the controller.

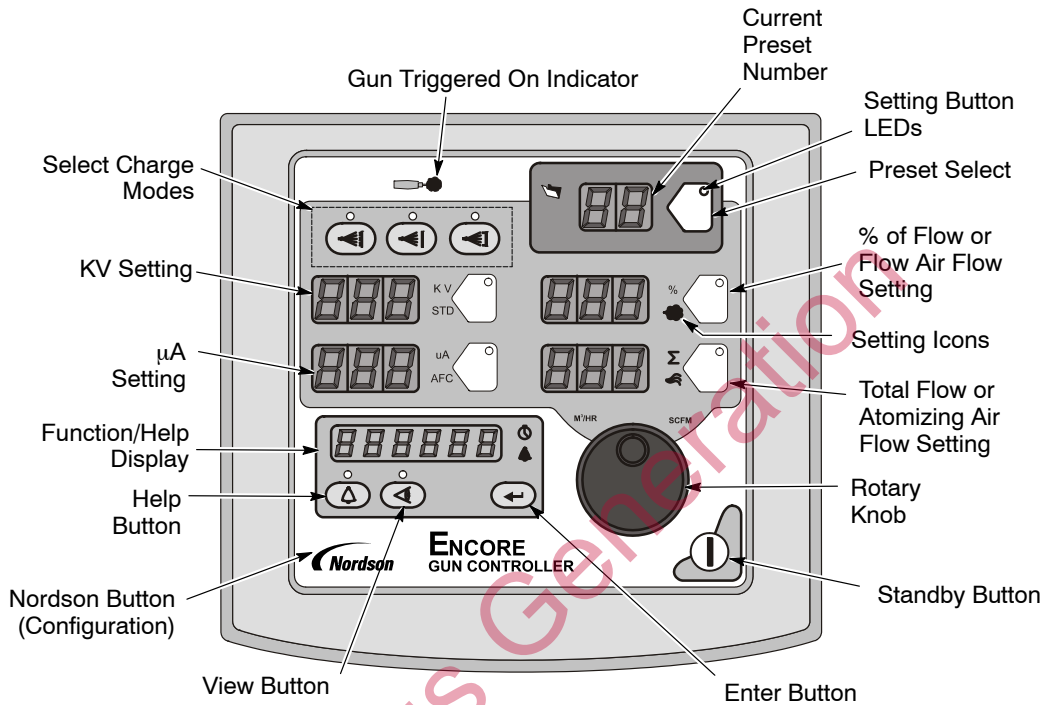

Figure 4-9 Controller Interface

The **Setpoint** icons light to indicate the configured or selected setpoints.

Setpoints include **Select Charge**, **KV**, **μ A**, **% of Flow** and **Total Flow**, or **Flow Air** and **Atomizing Air** flow rates.

To select a Preset or change a Preset setpoint, press the **Preset Select** button or a **Setpoint** button. The button LED lights to indicate that it is selected.

Use the **Rotary Knob** to change the selected setpoint: clockwise to increase, counter-clockwise to decrease. The setpoints reset to the minimum if increased past their maximum.



Selecting a Setpoint to Change



Changing a Setpoint

Figure 4-10 Selecting and Changing Setpoints

Help Codes



The Help icon in the Function/Help display lights if a problem occurs.

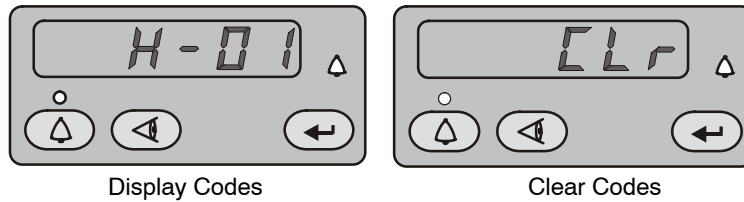

Figure 4-11 Displaying and Clearing Help Codes



To display the Help codes, press the **Help** button. The controller retains the last 5 codes in memory. Rotate the knob to scroll through the codes. The display blanks if there is no activity for 5 seconds.



To clear the Help codes, scroll through them until **CLr** is displayed, then press the **Enter** button. The Help icon stays lit until the controller clears the codes.

Refer to *Section 4, Troubleshooting* for help code troubleshooting, general system troubleshooting, resistance and continuity tests, and controller wiring diagrams.

Maintenance Timer, Total Hours, and Software Versions



Press the **View** button and turn the rotary knob to view, in the following order: Maintenance hours, Total hours, Gun Controller (GC), Gun Display (Gd), iFlow Module (FL) software versions and Hardware version (Hd). The Maintenance hour timer is set through *Controller Configuration* on page 4-20. Total hours cannot be reset.



The Help icon lights if the maintenance timer is set and runs out.



To reset the maintenance timer, press the **View** button.



The Timer icon lights when the maintenance hours are displayed. While they are displayed, press the **Enter** button.

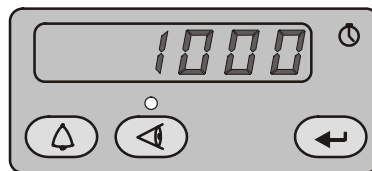

Figure 4-12 Displaying Maintenance Hours

Presets

Presets are programmed electrostatic and powder flow setpoints that allow the operator to quickly change spray settings simply by changing the preset number.

The controller can store 20 presets. Presets 1, 2, and 3 are programmed at the factory for the most common applications. Refer to page 4-7 for their setpoints. These setpoints can be adjusted as needed. Presets 4–17 can be programmed as needed.

Selecting a Preset

1. Press the **Preset** button. The button LED lights.
2. Turn the rotary knob. The preset number increases from 1 to 20 then resets to 1.

The setpoints for the selected preset are displayed when the gun is off.

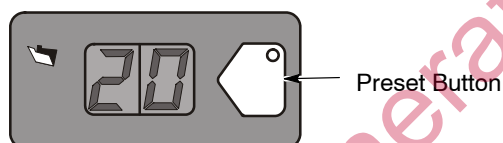

Figure 4-13 Preset Select

Electrostatic Settings

Electrostatic output can be in Select Charge mode, Custom mode, or Classic mode.

Select Charge[®] Mode

The Select Charge modes are non-adjustable electrostatic settings. The LEDs above the Select Charge mode buttons indicate the selected mode.

The Select Charge Modes and factory settings are:

Mode 1	Re-Coat	100 kV, 15 μ A
Mode 2	Metallics	50 kV, 50 μ A
Mode 3	Deep Recesses	100 kV, 60 μ A

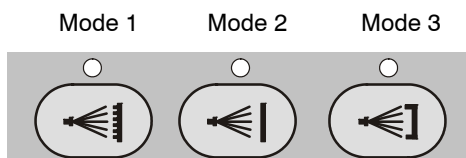

Figure 4-14 Select Charge Mode

NOTE: If the operator tries to adjust kV or μ A values while a Select Charge mode is selected, the controller will switch to Custom or Classic mode.

Custom Mode

Custom Mode is the factory default mode. In Custom mode, both kV and μ A can be adjusted independently. In Custom mode the STD and AFC icons are not displayed.

NOTE: Refer to *Controller Configuration* on page 4-20 for a list of the mode defaults and configuration instructions.

1. To set or change kV, press the KV button. The button LED lights to show that kV is selected.
2. Turn the rotary knob to increase or decrease the kV setpoint. The setpoint is automatically saved if it does not change for 3 seconds, or when any button is pressed.
3. To set or change the μ A setpoint, press the μ A button. The button LED lights to indicate that μ A is selected.
4. Turn the rotary knob to increase or decrease the μ A setpoint. The setpoint is automatically saved if it does not change for 3 seconds, or when any button is pressed.

NOTE: The default μ A range is 10–50 μ A. The limits of the range can be adjusted. Refer to *Controller Configuration* on page 4-20.

- When the gun is not triggered the kV and μ A setpoints are displayed.
- When the gun is triggered the actual kV and μ A outputs are displayed.

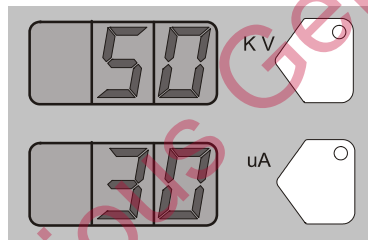

Custom Mode – Preset Setpoints

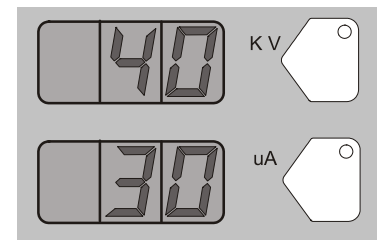

Custom Mode – Gun Triggered

Figure 4-15 Custom Mode – Preset Setpoints and Gun Triggered Displays

Classic Mode

To use Classic mode, the controller must be configured for it. Refer to *Controller Configuration* on page 4-20.

In Classic mode you can choose to control kV (STD) output or μ A (AFC) output, but not both at the same time.

Classic Standard (STD) Mode

Use the Standard mode to set kV. In Standard mode you cannot set μ A.

1. To set the kV setpoint, press the KV button. The button LED lights to show that kV is selected.

2. Turn the rotary knob to increase or decrease the kV setpoint. The setpoint is automatically saved if it does not change for 3 seconds, or when any button is pressed.
- When the gun is not triggered the kV setpoint is displayed.
 - When the gun is triggered the actual kV and μA outputs are displayed.

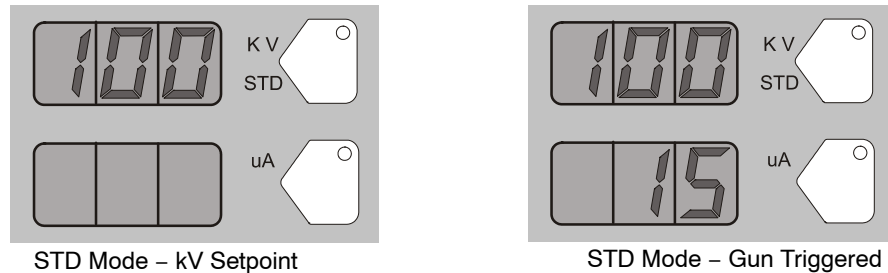

Figure 4-16 STD Mode – Setpoint and Gun Triggered Displays

Classic AFC Mode

Use the AFC mode to set μA output limits. In AFC mode you cannot adjust kV, it is automatically set to 100 kV.

1. To set μA , press the μA button. The button LED lights to show that μA is selected.
2. Turn the rotary knob to increase or decrease the μA setpoint. The setpoint is automatically saved if it does not change for 3 seconds, or when any button is pressed.

NOTE: The default μA range is 10–50 μA . The limits of the range can be adjusted. Refer to *Controller Configuration* on page 4-20.

- When the gun is not triggered the μA setpoint is displayed.

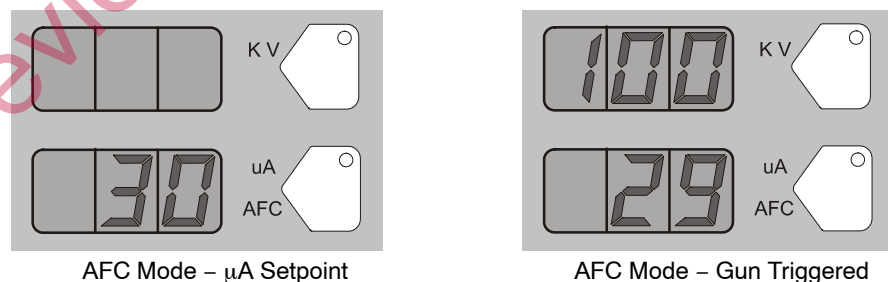

Figure 4-17 AFC Mode – Setpoint and Gun Triggered Displays

Powder Flow Settings

Two modes of powder flow control are available:

Smart Flow – This is the factory default mode. In this mode, you set Total Air (powder velocity) and Flow Air % (powder flow) setpoints. The controller automatically adjusts flow and atomizing air to the pump based on the setpoints. When the controller is configured for Smart Flow mode, the % and Σ icons are lit.

Powder Flow Settings (contd)

Classic Flow – This is the standard method of setting powder flow and velocity, by setting flow air and atomizing air flows separately and balancing them manually for optimum results. When the controller is configured for Classic Flow mode, the flow and atomizing air icons are lit.

NOTE: Refer to *Controller Configuration* on page 4-20 for a list of the mode defaults and configuration instructions.

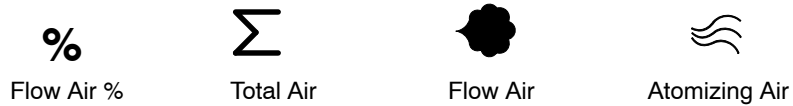

Figure 4-18 Powder Flow Icons

Smart Flow Mode

In Smart Flow mode, Total Flow sets the velocity of the powder flow, while Flow Air % sets the powder flow rate. Powder velocity is inversely related to transfer efficiency; the higher the velocity the lower the transfer efficiency.

When making Smart Flow settings, set the Total Flow setpoint first to obtain the desired pattern size and penetration, then set the Flow Air % setpoint for the desired powder flow.

Flow Air %: 0–100%. The actual percentage range available varies depending on the total air setpoint and the maximum and minimum outputs for flow and atomizing air.

Total Flow Σ : 2.55–10.2 M³/HR, minimum 0.17 M³/HR increments, or 1.5–6.0 SCFM, minimum 0.1 SCFM increments.

See Tables 3-1 and 3-2 for examples of possible Smart Flow settings and their equivalents in Atomizing and Flow Air pressures and flows. Figure 4-19 shows the effects of changes in Total Flow and Flow Air % settings.

The Smart Flow tables provide a range of possible Total Flow and Flow Air % setpoints. Read across to the vertical axis for the equivalent atomizing air flow and pressure. Read down to the horizontal axis for the equivalent flow-air flow and pressure.

The tables show that as you increase Total Flow powder velocity increases while the maximum Flow Air % remains the same. Conversely, for a given Total Flow setting, each increase in Flow Air % increases powder flow.

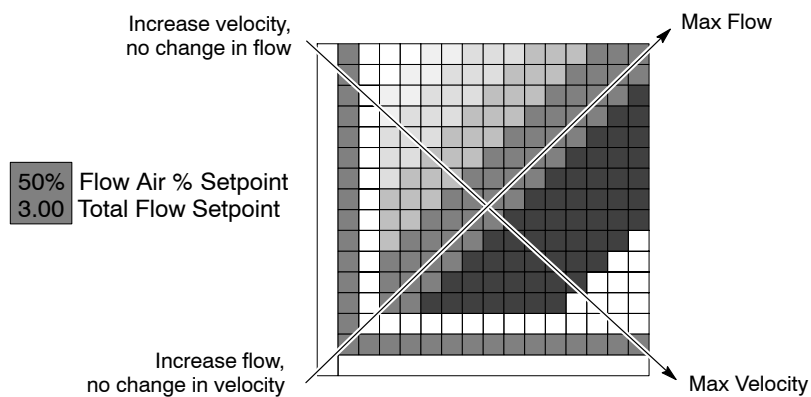

Figure 4-19 Reading the Smart Flow Tables

Setting Smart Flow Setpoints

To set flow air % or total flow Σ :

1. Press the % or Σ button. The LED on the selected button lights.
2. Turn the knob to increase or decrease the setpoint. The setpoint is automatically saved if it does not change for 3 seconds or when any button is pressed.

NOTE: If Total Flow is set to zero, the Flow Air % setpoint cannot be set to anything but zero, and powder cannot be sprayed. To set Flow Air %, set Total Flow to a value greater than zero.

- When the spray gun is not triggered the setpoints are displayed.
- When the spray gun is triggered the displays show actual flows.

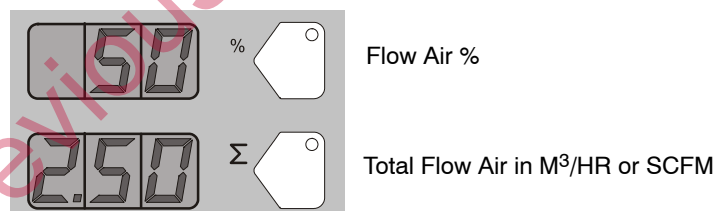
Figure 4-20 Smart Flow Mode – Flow Air % or Total Flow Σ

Smart Flow Settings – Metric Units

Powder Velocity (M ³ /Hr) (Total Flow)		Sure Coat w/100+ Pump: ♦ Air Flow Settings: 1.0 bar Atomizing 2.0 bar Flow Powder Output: 150 g/min. Max. Powder Flow Rate: ★
Low	<3.40	
Soft	3.40–4.25	
Medium	4.25–5.53	
Firm	5.53–7.23	
High	>7.23	

Table 4-1 Smart Flow Settings – Metric Units

Atomizing	0.4	0.85	X	X	67% 2.55	71% 2.97	75% 3.40	78% 3.82	80% 4.25	82% 4.67	83% 5.10	85% 5.52	86% 5.95	87% 6.37	88% 6.80 ★
	0.6	1.27	X	50% 2.54	57% 2.97	63% 3.39	67% 3.82	70% 4.24	73% 4.67	75% 5.09	77% 5.52	79% 5.94	80% 6.37	81% 6.79	82% 7.22
	0.9	1.70	33% 2.55	43% 2.97	50% 3.40	55% 3.82	60% 4.25	64% 4.67	67% 5.10	69% 5.52	71% 5.95	73% 6.37	75% 6.80	76% 7.22	78% 7.65
	1.2	2.12	29% 2.97	37% 3.39	45% 3.82	50% 4.24	55% 4.67	58% 5.09	62% 5.52	64% 5.94	67% 6.37	69% 6.79	71% 7.22	72% 7.64	74% 8.07
	1.6	2.55	25% 3.40	33% 3.82	40% 4.25	45% 4.67	50% 5.10 ♦	54% 5.52	57% 5.95	60% 6.37	63% 6.80	65% 7.22	67% 7.65	68% 8.07	70% 8.50
	1.9	2.97	22% 3.82	30% 4.24	36% 4.67	42% 5.09	46% 5.52	50% 5.94	53% 6.37	56% 6.79	59% 7.22	61% 7.64	63% 8.07	65% 8.49	67% 8.92
	2.3	3.40	20% 4.25	27% 4.67	33% 5.10	38% 5.52	43% 5.95	47% 6.37	50% 6.80	53% 7.22	56% 7.65	58% 8.07	60% 8.50	62% 8.92	64% 9.35
	2.7	3.82	18% 4.67	25% 5.09	31% 5.52	36% 5.94	40% 6.37	44% 6.79	47% 7.22	50% 7.64	53% 8.07	55% 8.49	57% 8.92	59% 9.34	61% 9.77
	3.1	4.25	17% 5.10	23% 5.52	29% 5.95	33% 6.37	38% 6.80	41% 7.22	44% 7.65	47% 8.07	50% 8.50	52% 8.92	55% 9.35	56% 9.77	58% 10.20
	3.5	4.67	15% 5.52	21% 5.94	27% 6.37	31% 6.79	35% 7.22	39% 7.64	42% 8.07	45% 8.49	48% 8.92	50% 9.34	52% 9.77	54% 10.19	X
	3.6	5.10	14% 5.95	20% 6.37	25% 6.80	29% 7.22	33% 7.65	37% 8.07	40% 8.50	43% 8.92	45% 9.35	48% 9.77	50% 10.20	X	X
		5.52	13% 6.37	19% 6.79	24% 7.22	28% 7.64	32% 8.07	35% 8.49	38% 8.92	41% 9.34	44% 9.77	46% 10.19	X	X	X
		5.95	13% 6.80	18% 7.22	22% 7.65	26% 8.07	30% 8.50	33% 8.92	36% 9.35	39% 9.77	42% 10.20	X	X	X	X
		M³/Hr	0.85	1.27	1.70	2.12	2.55	2.97	3.40	3.82	4.25	4.67	5.10	5.52	5.95
BAR		0.2	0.3	0.5	0.8	1.1	1.4	1.7	2.0	2.3	2.6	2.9	3.2	3.5	
Flow															

Smart Flow Settings – English Units

Powder Velocity (SCFM) (Total Flow)		Sure Coat w/100+ Pump: ♦ Air Flow Setting: 15 psi Atomizing 20 psi Flow Powder Output: 20 lb/hr Max. Powder Flow Rate: ★
Low	<2.00	
Soft	2.00–2.50	
Medium	2.75–3.25	
Firm	3.50–4.25	
High	>4.25	

Table 4-2 Smart Flow Settings – English Units

Atomizing	5	0.50	X	X	67% 1.50	71% 1.75	75% 2.00	78% 2.25	80% 2.50	82% 2.75	83% 3.00	85% 3.25	86% 3.50	87% 3.75	★88% 4.00
	9	0.75	X	50% 1.50	57% 1.75	63% 2.00	67% 2.25	70% 2.50	73% 2.75	75% 3.00	77% 3.25	79% 3.50	80% 3.75	81% 4.00	82% 4.25
	13	1.00	33% 1.50	43% 1.75	50% 2.00	56% 2.25	60% 2.50	64% 2.75	67% 3.00	69% 3.25	71% 3.50	73% 3.75	75% 4.00	76% 4.25	78% 4.50
	18	1.25	29% 1.75	38% 2.00	44% 2.25	50% 2.50	55% 2.75	58% 3.00	62% 3.25	64% 3.50	67% 3.75	69% 4.00	71% 4.25	72% 4.50	74% 4.75
	23	1.50	25% 2.00	33% 2.25	40% 2.50	45% 2.75	50% 3.00	54% 3.25	57% 3.50	60% 3.75	63% 4.00	65% 4.25	67% 4.50	68% 4.75	70% 5.00
	28	1.75	22% 2.25	30% 2.50	36% 2.75	♦ 42% 3.00	46% 3.25	50% 3.50	53% 3.75	56% 4.00	59% 4.25	61% 4.50	63% 4.75	65% 5.00	67% 5.25
	34	2.00	20% 2.50	27% 2.75	33% 3.00	38% 3.25	43% 3.50	47% 3.75	50% 4.00	53% 4.25	56% 4.50	58% 4.75	60% 5.00	62% 5.25	64% 5.50
	40	2.25	18% 2.75	25% 3.00	31% 3.25	36% 3.50	40% 3.75	44% 4.00	47% 4.25	50% 4.50	53% 4.75	55% 5.00	57% 5.25	59% 5.50	61% 5.75
	45	2.50	17% 3.00	23% 3.25	29% 3.50	33% 3.75	38% 4.00	41% 4.25	44% 4.50	47% 4.75	50% 5.00	52% 5.25	55% 5.50	57% 5.75	58% 6.00
	51	2.75	15% 3.25	21% 3.50	27% 3.75	31% 4.00	35% 4.25	39% 4.50	42% 4.75	45% 5.00	48% 5.25	50% 5.50	52% 5.75	54% 6.00	X
	52	3.00	14% 3.50	20% 3.75	25% 4.00	29% 4.25	33% 4.50	37% 4.75	40% 5.00	43% 5.25	45% 5.50	48% 5.75	50% 6.00	X	X
		3.25	13% 3.75	19% 4.00	24% 4.25	28% 4.50	32% 4.75	35% 5.00	38% 5.25	41% 5.50	43% 5.75	46% 6.00	X	X	X
		3.50	13% 4.00	18% 4.25	22% 4.50	26% 4.75	30% 5.00	33% 5.25	36% 5.50	39% 5.75	42% 6.00	X	X	X	X
		SCFM	0.50	0.75	1.00	1.25	1.50	1.75	2.00	2.25	2.50	2.75	3.00	3.25	3.50
	PSI	3	5	8	12	16	20	24	29	34	38	42	47	51	
Flow															

Classic Flow Mode Settings

To use Classic Flow mode, the controller must be configured for it. Refer to *Controller Configuration* on page 4-20.

In Classic Flow mode, flow air and atomizing air ranges are:

- Flow air from 0–5.95 M³/HR (0–3.5 SCFM in 0.05 increments).
- Atomizing air from 0–5.95 M³/HR (0–3.5 SCFM in 0.05 increments).

To set flow or atomizing air:

1. Press the Flow or Atomizing button. The green LED on the selected button lights.
2. Turn the knob to increase or decrease the setpoints. The setpoint is automatically saved if it does not change for 3 seconds or when any button is pressed.

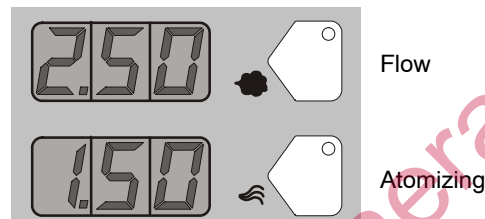

Figure 4-21 Classic Mode – Flow Air or Atomizing Air Flow Setpoints

- When the spray gun is not triggered the setpoints are displayed.
- When the spray gun is triggered the actual flows are displayed.

Controller Configuration

Opening the Function Menu and Making Settings

Nordson Press and hold the Nordson button for 5 seconds. The Function/Help display lights to show the Function numbers and values. Use the Functions to configure the controller for your application.

The Function numbers are in the form F00–00 (Function number–value).

To scroll through the function numbers rotate the knob. To select the displayed function number, press the Enter button.

When the function is selected the function value blinks. To change the function value, rotate the knob. Press the Enter button to save the change and exit the value, so that rotating the knob now scrolls through the function numbers.

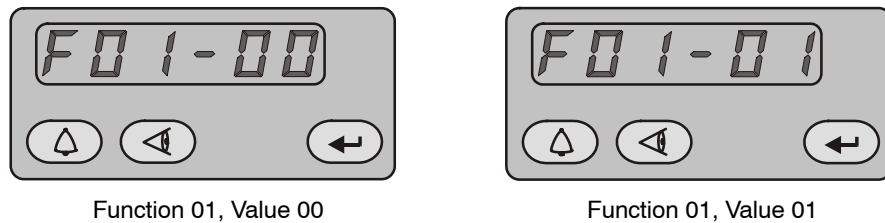

Figure 4-22 Displaying and Changing Configuration Functions

Table 4-1 Function Settings

Function Number	Function Name	Function Values	Default Value
F00	Gun Type	00=Encore	00
F01	Fluidizing	00=Hopper, 01=Box, 02= Disable	00
F02	Display Units	00=SCFM, 01=M ³ /HR	00
F03	Electrostatic Control	00=Custom, 01=Classic (STD, AFC)	00
F04	Powder Flow Control	00=Smart, 01=Classic	00
F05	Keypad Lockout	00=Unlocked, 01=Locked	00
F06	Vibratory Box Delay Off	on, 00–90 seconds (on=continuous operation)	30 sec
F07	Maintenance Timer	00=Disable, 00–999 hours	00
F08	Settings Trigger Function	00=Increase/Decrease Preset or Flow, 01=Disable, 02=Flow only, 03=Preset only, 04=Purge, 05=Trigger	00
F09	Help Codes	00=Enable, 01=Disable	00
F10	Zero Reset (Flow)	00=Normal, 01=Reset (See Note below)	00
F11	Gun Display Errors	00=Flashing, 01=Disable	00
F12	µA Lower Limit	00=10 µA, 01=5µA, 02=1 µA	00
F13	µA Upper Limit	00=50 µA, 01=100 µA	00
F14	Total Hours	View Only	–
F15	Save/Restore/Reset	00=System Save, 01=System Restore, 02=Factory Reset	00
F16	Gun Display Brightness	00=Low, 01=Medium, 02=Maximum	01
F17	Number of Presets	01–20 presets	20

NOTE: Refer to *Section 4, Troubleshooting* for the Zero Reset procedure.

Vibratory Box Feeder On Continuously

NOTE: These instructions are only for systems equipped with vibratory box feeders. If your system uses a feed hopper, set function F01 to F01–00.

To set the vibrator motor to continuous operation, do the following:

1. Press the Nordson button for 5 seconds.
2. Set custom function F01 to F01–01 (Box Feeder).
3. Set F06 to F06–On. The default setting is F06–30. To set it to On, rotate the knob counterclockwise to decrement the numbers past 0 to On.

Vibratory Box Feeder On Continuously (contd)

4. Press Enter to set the value to On, then press the Nordson button to exit the Functions menu.
5. To turn the vibrator on, press and release the spray gun trigger. The vibrator will stay on when the trigger is released.
6. To turn the vibrator off, press the Standby button or turn off controller power. To turn the vibrator back on press and release the spray gun trigger again.

Saving and Loading Preset and Function Settings

To save the current preset and function settings, set F15 to F15-00 and press Enter. All current preset and function settings are saved to memory.

To restore the saved preset and function settings, set F15 to F15-01 and press Enter. All the previously saved preset and function settings will be restored from memory.

To restore the system to the factory defaults, set F15 to F15-02, then press Enter.

Setting the Number of Presets

Custom Function F17 allows the user to set the number of valid presets between 1 and 20. For example, if the function is set to F17-05, then only 5 presets can be set up and toggled between on the interface and gun.

If the function is set to F17-01, then only the current settings on the interface are used, as if there are no presets.

Section 5

Troubleshooting



WARNING: Allow only qualified personnel to perform the following tasks. Follow the safety instructions in this document and all other related documentation.



WARNING: Before making repairs to the controller or spray gun, shut off system power and disconnect the power cord. Shut off the compressed air supply to the system and relieve the system pressure. Failure to observe this warning could result in personal injury.

These troubleshooting procedures cover only the most common problems. If you cannot solve a problem with the information given here, contact Nordson technical support at (800) 433-9319 or your local Nordson representative for help.

Help Code Troubleshooting



The Help icon in the Function/Help display lights if a problem occurs that the controller can sense.

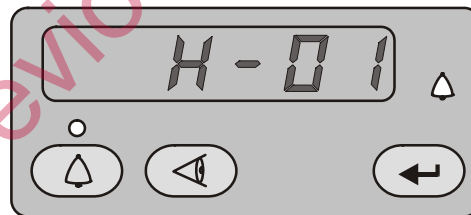

Figure 5-1 Displaying and Clearing Help Codes

Viewing Help Codes



Press the **Help** button to display the Help codes. The controller retains the last 5 codes in memory. Rotate the knob to scroll through the codes. The display will blank if there is no activity for 5 seconds.

Clearing Help Codes



To clear the help codes, press the **Help** button, then scroll through them until **CLr** is displayed, then press the **Enter** button. The Help icon will stay lit until the controller clears the codes.

Help Code Troubleshooting Chart

Code	Message	Correction
H07	Gun Open	Trigger the gun and check the display. If the μA feedback is 0, check for a loose gun cable connection at the gun receptacle. Check for a loose connection to the power supply inside the gun. Perform the <i>Gun Cable Continuity Tests</i> on page 5-11. If the cable and the connections are okay, check the spray gun power supply.
H10	Gun Output Stuck Low	With the gun triggered on and the kV set to maximum, use a multimeter set for VRMS to check for voltage between J4 pins 1 and 2 on the main control board. If no voltage is present replace the main control board.
H11	Gun Output Stuck High	Make sure kV is set to 0 and the gun is triggered OFF. The μA display should read 0. If the μA display is greater than 0, replace the main control board. Make sure the trigger icon on the interface is not lit.
H12	Communications Fault CAN Bus	Check the power unit/interface interconnect cable. Make sure the cable connections are secure and the cable is not damaged. Refer to <i>Gun Cable Continuity Tests</i> on page 5-11. Check the connections from the cable receptacle to the J1 terminal block on the main control board. If all connections are secure but the fault persists replace the cable.
H15	Over Current Fault (Cable or Gun Short)	This fault can occur if the gun tip touches a grounded part while spraying. This fault turns the electrostatic output off. Clear the help codes to reset the fault and resume spraying. If the fault reoccurs, disconnect the spray gun power supply from the gun cable inside the gun and trigger the gun on. Refer to the <i>Power Supply Replacement</i> procedure in <i>Section 6, Repair</i> . If the H15 code does not reappear, then the power supply is shorted. Replace the spray gun power supply. If the help code reappears, check the gun cable continuity and replace it if shorted. Perform the <i>Gun Cable Continuity Tests</i> on page 5-11.
H19	Maintenance Timer Expired	The Maintenance Timer has exceeded its setting. Perform the scheduled maintenance, then reset the maintenance timer. Refer to <i>Section 4, Operation</i> , for reset instructions.
H21	Atomizing Air Valve Fault	Refer to the controller wiring diagrams in this section. Check the wiring harness connection to J8 and the proportional valve solenoid. Check the solenoid operation. Replace the valve if the solenoid is not working.
H22	Flow Air Valve Fault	Refer to the controller wiring diagrams in this section. Check the wiring harness connection to J7 and the proportional valve solenoid. Check the solenoid operation. Replace the valve if the solenoid is not working.
<i>Continued..</i>		

Code	Message	Correction
H23	Flow Air Flow Low Fault	<p>The flow setting may be too high for the system to achieve. Maximum air flow is dependent on factors including air tubing length, diameter, and pump type.</p> <p>Switch to Classic Flow mode. This mode lets you set and view actual flow-rate and atomizing air flow so you can diagnose the problem.</p> <p>Check the tubing from the iFlow module to the powder pump for kinks or blockage. Make sure the check valves are not blocked. Disconnect the air tubing at the pump, clear the help codes, and trigger the gun. If the help code does not reappear, clean or replace the pump venturi nozzle or throat.</p>
H24	Atomizing Air Flow Low Fault	<p>Check the tubing from the iFlow module to the powder pump for kinks or blockage. Make sure the check valves are not blocked. Disconnect the air tubing at the pump, clear the help codes, and trigger the gun. If the help code does not reappear, clean or replace the pump venturi nozzle or throat.</p> <p>Check the system air supply pressure. Pressure must be above 5.86 bar (85 psi). Check the system filter and the tubing from the filter to the power unit for kinks or blockage.</p> <p>Refer to <i>Section 6, Repair</i> for procedures using the iFlow Air Flow Verification Kit to check the operation of the iFlow module proportional valves and the output of the precision air pressure regulator.</p>
H25	Flow Air Flow High Fault	<p>Switch to Classic Flow mode. This mode lets you set and view actual flow and atomizing air so you can diagnose the problem.</p> <p>If the spray gun is triggered off when the help code appears, disconnect the air tubing from the appropriate air output fitting and plug the fitting. Clear the help codes. If the code does not reappear then the proportional valve is stuck open. Refer to <i>Section 5, Repair</i> for cleaning instructions.</p> <p>If the spray gun is triggered on when the help code appears, disconnect the air tubing from the appropriate output fitting and set the flow to zero. If air is still flowing from the fitting then plug the fitting and clear the help codes. If the code does not reoccur then the proportional valve is stuck open. Refer to <i>Section 6, Repair</i> for cleaning instructions.</p>
H26	Atomizing Airflow High Fault	<p>If the help code re-occurs and the controller interface is showing air flow, then check for leaks around the proportional valves or transducers on the iFlow module.</p> <p>If the help code persists, re-zero the module as described on page 5-9.</p> <p>Refer to <i>Section 6, Repair</i> for procedures using the iFlow Air Flow Verification Kit to check the operation of the iFlow module proportional valves and the output of the precision air pressure regulator.</p>
H27	Trigger On during Power Up Fault	<p>This code appears if the gun was triggered on when the interface was turned on. Turn off the interface, wait for several seconds, then turn the interface back on, making sure the spray gun is not triggered on. If the fault reoccurs, check for a bad trigger switch.</p>
H28	EEPROM Data Version Changed	<p>Software version has been changed. This code appears after a software update. Clear the fault. It should not reappear.</p>

Continued..

Code	Message	Correction
H31	Boost Valve Fault (J6)	Refer to the power unit wiring diagrams in Figures 4-6 and 4-7. Check the wiring harness connections to the valve solenoids. Check the solenoid operation by placing a finger on the solenoid and triggering the appropriate function. (The boost air solenoid should open when flow air is set to above 3.0 SCFM or 5.10 M ³ /Hr.) You should be able to feel the solenoid open and close if it is functioning correctly.
H32	Electrode Air Wash Valve Fault (J4)	Refer to the power unit wiring diagrams in Figures 4-6 and 4-7. Check the wiring harness connections to the valve solenoids. Check the solenoid operation by placing a finger on the solenoid and triggering the appropriate function. (The boost air solenoid should open when flow air is set to above 3.0 SCFM or 5.10 M ³ /Hr.) You should be able to feel the solenoid open and close if it is functioning correctly.
H33	Fluidizing Air Valve Fault (J5)	Refer to the power unit wiring diagrams in Figures 4-6 and 4-7. Check the wiring harness connections to the valve solenoids. Check the solenoid operation by placing a finger on the solenoid and triggering the appropriate function. (The boost air solenoid should open when flow air is set to above 3.0 SCFM or 5.10 M ³ /Hr.) You should be able to feel the solenoid open and close if it is functioning correctly.
H34	Purge Air Valve Fault (J10)	Refer to the controller wiring diagrams in this section. Check the wiring harness connections to the valve solenoids. Check the solenoid operation by placing a finger on the solenoid and triggering the appropriate function. You should be able to feel the solenoid open and close if it is functioning correctly.
H35	Vibratory Motor Valve Fault (VBF units only)	Check the J9 connection for the relay inside the power unit. If the harness becomes disconnected or the relay coil is damaged, this fault appears.
H36	Communications Fault LIN Bus	Check the gun cable connection at the interface module receptacle. See Figure 5-1. Check the cable/display module J3 connector inside the gun. Make sure the connectors and pins are not damaged and connection is secure. Check the gun cable for opens or shorts. If gun display lights up, but shows CF on back of the display and cable and connections are OK replace gun display module.
H41	24V Fault	Check the DC power supply located in the power unit. See Figure 4-6 for pinout. If the voltage is less than 22 Vdc replace the power supply. Turn on the power unit for this test.
H42	Main Board Fault (Interface)	Clear the fault and make sure kV is set to maximum 100 kV, then trigger the gun ON. If the code re-appears, check for a defective gun power supply or a gun cable. If the cable and the gun power supply are OK, replace the main board.
H43	μA Feedback Fault	Make sure kV is set to maximum 100 kV, trigger the gun ON and check the μA display. If the μA display always reads >75 μA, even when the gun is more than 3 ft from a grounded surface, check the gun cable or the gun power supply. If the μA display reads 0 with the gun triggered on and close to a part, check the gun cable or the gun power supply. When the gun is triggered on and kV is set >0, the μA display should always read >0.

General Troubleshooting Chart

Problem	Possible Cause	Corrective Action
1. Uneven pattern, unsteady or inadequate powder flow	Blockage in spray gun, powder feed hose, or pump	<ol style="list-style-type: none"> 1. Purge the spray gun. Remove the nozzle and electrode assembly and clean them. 2. Disconnect the powder feed hose from the spray gun and blow out the gun with an air gun. 3. Disconnect the feed hose from the pump and gun and blow out the feed hose. Replace the feed hose if it is clogged with powder. 4. Disassemble and clean the pump. 5. Disassemble the spray gun. Remove the inlet and outlet tubes and elbow and clean them. Replace components as necessary.
	Nozzle, deflector, or electrode assembly worn, affecting pattern	Remove, clean, and inspect the nozzle, deflector, and electrode assembly. Replace worn parts as necessary. If excessive wear or impact fusion is a problem, reduce the flow rate and atomizing air flow.
	Damp powder	Check the powder supply, air filters, and dryer. Replace the powder supply if contaminated.
	Low atomizing or flow air pressure	Increase the atomizing and/or flow air flow.
	Improper fluidization of powder in hopper	Increase the fluidizing air pressure. If the problem persists, remove the powder from the hopper. Clean or replace the fluidizing plate if contaminated.
	iFlow module out of calibration	Perform the Re-Zero Procedure on page 5-9.
2. Voids in powder pattern	Worn nozzle or deflector	Remove and inspect the nozzle or deflector. Replace worn parts.
	Plugged electrode assembly or powder path	Remove the electrode assembly and clean it. Remove powder path if necessary and clean it.
	Electrode air wash flow too high	Adjust the needle valve at the power unit to decrease the electrode air wash flow.

Continued...

Problem	Possible Cause	Corrective Action
3. Loss of wrap, poor transfer efficiency	NOTE: Before checking possible causes, check the help code on the controller and perform the corrective actions recommended in this section.	
	Low electrostatic voltage	Increase the electrostatic voltage.
	Poor electrode connection	Remove the nozzle and electrode assembly. Clean the electrode and check for carbon tracking or damage. Check the electrode resistance as shown on page 5-10. If the electrode assembly is good, remove the gun power supply and check its resistance as shown on page 5-10.
	Poorly grounded parts	Check the conveyor chain, rollers, and part hangers for powder buildup. The resistance between the parts and ground must be 1 megohm or less. For best results, 500 ohms or less is recommended.
4. No kV output from the spray gun (display shows 0 kV when gun triggered), but powder is spraying	NOTE: Before checking possible causes, check the help code on the controller and perform the corrective actions recommended in this section.	
	Damaged gun cable	Perform the <i>Gun Cable Continuity Checks</i> on page 5-11. If an open or short is found, replace the cable.
	Spray gun power supply shorted	Perform the <i>Power Supply Resistance Test</i> on page 5-10.
5. Powder build up on the electrode tip	Insufficient electrode air wash flow	Adjust the electrode air wash needle valve at the power unit to increase the electrode air wash flow.
6. No kV output from the spray gun (display shows voltage or μA output), but powder is spraying	NOTE: Before checking possible causes, check the help code on the controller and perform the corrective actions recommended in this section.	
	Spray gun power supply open	Perform the <i>Power Supply Resistance Test</i> on page 5-10.
	Damaged gun cable	Perform the <i>Gun Cable Continuity Test</i> on page 5-11. If an open or short is found, replace the cable.
7. No kV output and no powder output	Malfunctioning trigger switch, display module, or cable	Check the "Gun Triggered On" icon at the top center of the controller interface. If the icon is not lit, check for a H36 help code. Check the trigger switch connections to the display module, replace the switch if necessary. Perform the <i>Gun Cable Continuity Test</i> on page 5-11. NOTE: It may be possible to use the settings trigger as the spray trigger until repairs are made. Set Function F08 to F08-05. Refer to page 4-21.

Continued...

Problem	Possible Cause	Corrective Action
8. No purge air when Purge button is pressed	Malfunctioning spray gun display module, gun cable, or iFlow module purge solenoid valve; no air pressure, or kinked air tubing	If display module does not show PU when purge button is pressed, then module membrane switch is defective. Replace display module. If display module shows PU : Check the purge air tubing and solenoid valve on the iFlow manifold. Perform the <i>Gun Cable Continuity Test</i> on page 5-11.
9. Low powder flow or powder flow surging	Low supply air pressure	Input air must be greater than 5.86 bar (85 psi).
	Air pressure regulator set too low	Adjust the input regulator so that the pressure is greater than 5.86 bar (85 psi).
	Supply air filter plugged or filter bowl full – water contamination of flow controller	Remove bowl and drain water/dirt. Replace filter element if necessary. Clean system, replace components if necessary.
	Flow valve plugged (H24 or H25)	See <i>Proportional Valve Cleaning</i> in this section.
	Air tubing kinked or plugged (H24 or H25)	Check flow and atomizing air tubing for kinks.
	Pump throat worn	Replace pump throat.
	Pump not assembled correctly	Check and re-assemble pump.
	Pick-up tube blocked	Check for debris or bag (VBF units) blocking pick-up tube.
	Vibratory box feeder disabled (VBF units only)	Set the Custom Function F01 for a box feeder (F01-01). See <i>Controller Configuration</i> on page 4-21.
	Fluidizing air too high	If fluidizing air is set too high the ratio of powder to air will be too low.
	Fluidizing air too low	If fluidizing air is set too low the pump will not operate at peak efficiency.
	Powder hose plugged	Blow out powder hose with compressed air.
	Powder hose kinked	Checked for a kinked powder hose.
	Powder hose too long	Shorten hose.
	Gun powder path plugged	Check powder inlet tube, elbow, and electrode support for impact fusion or debris. Clean as necessary with compressed air.
	Flow and atomizing air tubing reversed	Check flow and atomizing air tubing routing and correct if incorrect.

Problem	Possible Cause	Corrective Action
10. Gun display module shows CF	Loose gun display connection	See Figure 5-7. Check connector J3 (cable/display module) inside the gun. Check for loose or bent pins.
	Defective gun cable or gun display module (H36 code)	Perform the <i>Gun Cable Continuity Test</i> on page 5-11. Replace cable if damaged. Replace gun display module if cables and connections are good.
11. Preset cannot be changed from the spray gun	Settings trigger disabled	Check Custom Function F08 and set to enabled (F08-00). See <i>Controller Configuration</i> on page 4-21.
	No programmed preset available	Presets with no set values for flow rate and electrostatics are automatically skipped.
	Loose or defective trigger switch	See Figure 5-7. Check for a loose trigger switch connection. The trigger switch is plugged into the gun display module.
12. Powder flow cannot be changed from the spray gun	Settings trigger disabled	Check Custom Function F08 and set to enabled (F08-00). See <i>Controller Configuration</i> on page 4-21.
	Total air set to zero	If the total air is set to zero the flow percent cannot be adjusted. Change the total flow to a non-zero number.
	Loose or defective trigger switch	See Figure 5-7. Check for a loose trigger switch connection. The trigger switch is plugged into the gun display module.
13. VBF doesn't turn ON and Off with the gun trigger	VBF turned off	Set the Custom Function F01 for a box feeder (F01-01). See <i>Controller Configuration</i> on page 4-21.
14. Fluidizing Air is on all the time even when the gun is triggered Off	System is setup for a hopper	Set the Custom Function F01 for a box feeder (F01-01). See <i>Controller Configuration</i> on page 4-21.
15. No KV when gun is triggered ON, powder flow OK	KV set to zero	Set KV to a non-zero value.
	Check for Help Codes and follow the procedures	
16. No powder flow when gun is triggered ON, kV OK	Total air set to zero	Change total flow to a non-zero number.
	Input air turned OFF	Check the gauge on the filter regulator and make sure the air is turned ON. See Figure 2-13.
	Check for Help Codes and follow the procedures	
17. Gun flow % does not increment, always 0	Total air set to zero	If the total air is set to zero the flow percent cannot be adjusted. Change the total flow to a non-zero number.

Re-Zero Procedure

Perform this procedure if the controller interface indicates air flow when the spray gun is not triggered on, or if a Flow Air or Atomizing Air Flow High Help code (H25 or H26) appears.

Before performing a re-zero procedure:

- Make sure the air pressure being supplied to the system is higher than the minimum 5.86 bar (85 psi).
 - Make sure no air is leaking through the module output fittings or from around the solenoid valves or proportional valves. Re-zeroing modules with leaks will result in additional errors.
1. At the power unit, disconnect the flow and atomizing air tubing and install 8-mm plugs in the output fittings.
 2. Press the Nordson button for 5 seconds to display the controller functions. F00-00 is displayed.
 3. Rotate the knob until F10-00 is displayed.
 4. Press the Enter button, then rotate the knob to display F10-01.
 5. Press the Enter button. The controller will re-zero the flow and atomizing air and reset the function display to F10-00.
 6. Remove the plugs from the flow and atomizing air output fittings and reconnect the air tubing.

Spray Gun Power Supply Resistance Test

Use a megohm meter to check the resistance of the power supply, from the J2-3 feedback terminal at the connector to the contact pin inside the front end. The resistance should be between 280–320 megohms. If the reading is infinite, switch the meter probes. If the resistance falls outside this range, replace the power supply.

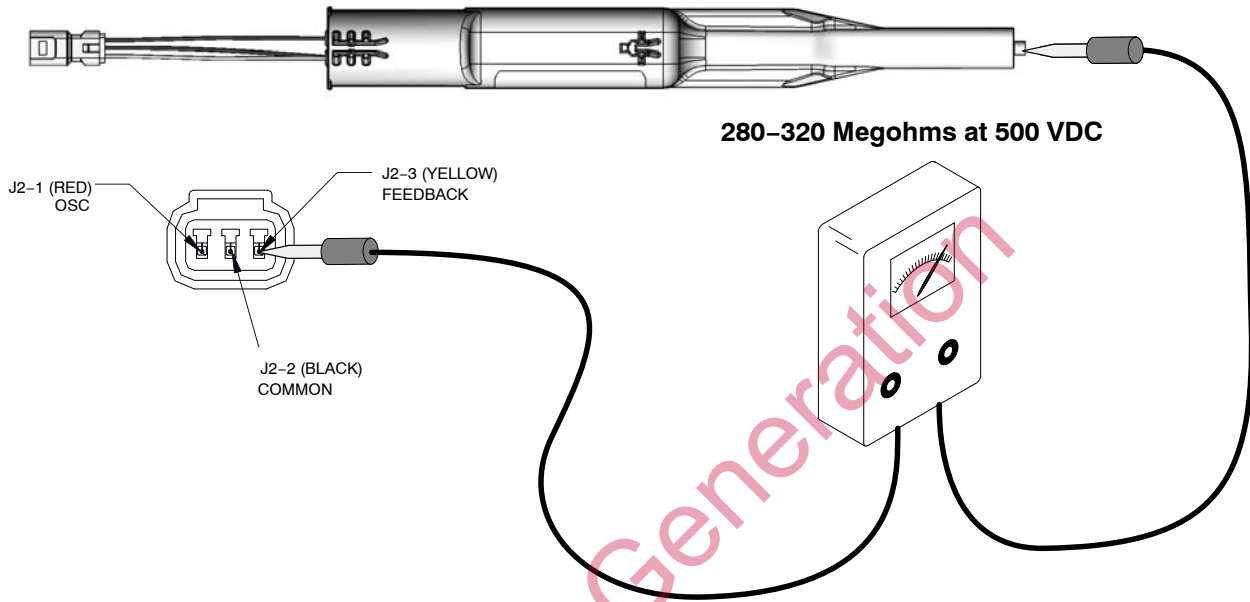

Figure 5-2 Power Supply Resistance Test

Electrode Assembly Resistance Test

Use a megohm meter to measure the resistance of the electrode assembly from the contact ring on the back to the antenna wire in the front. The resistance should be 19–21 megohms. If the resistance is out of this range replace the electrode assembly.

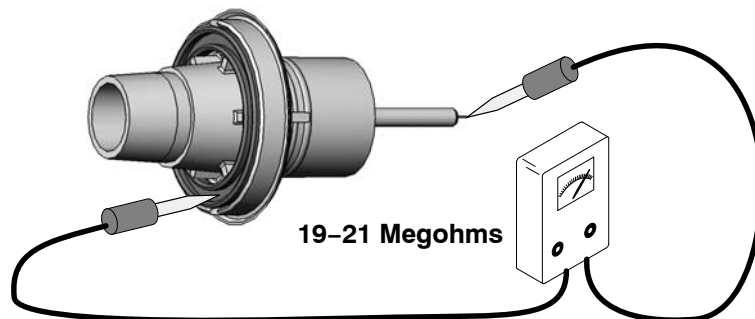

Figure 5-3 Electrode Assembly Resistance Test

Gun Cable Continuity Test

Test for continuity as follows:

- J1-1 and J3-3
- J1-2 and J2-2
- J1-2 and J3-2
- J1-3 and J2-1
- J1-4 and J3-1
- J1-5 and J2-3
- J1-6 and Ring-tong terminal on gun end.

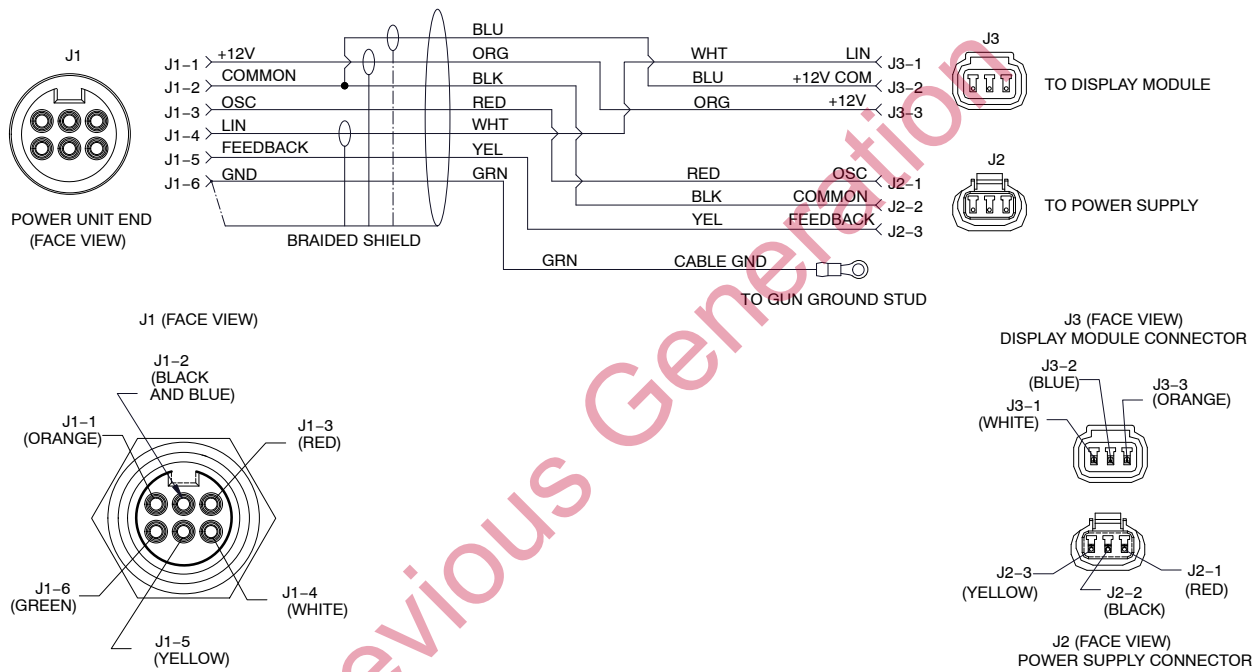

Figure 5-4 Gun Cable Wiring

Controller Interconnect Cable Test

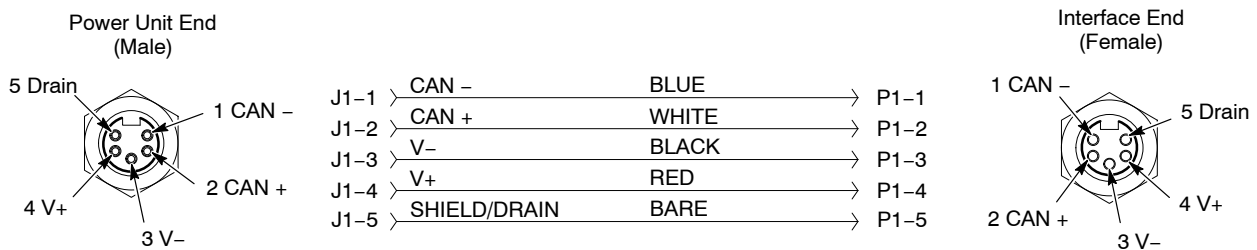

Figure 5-5 Controller Interconnect Cable Wiring

System Wiring Diagrams

Power Unit Wiring

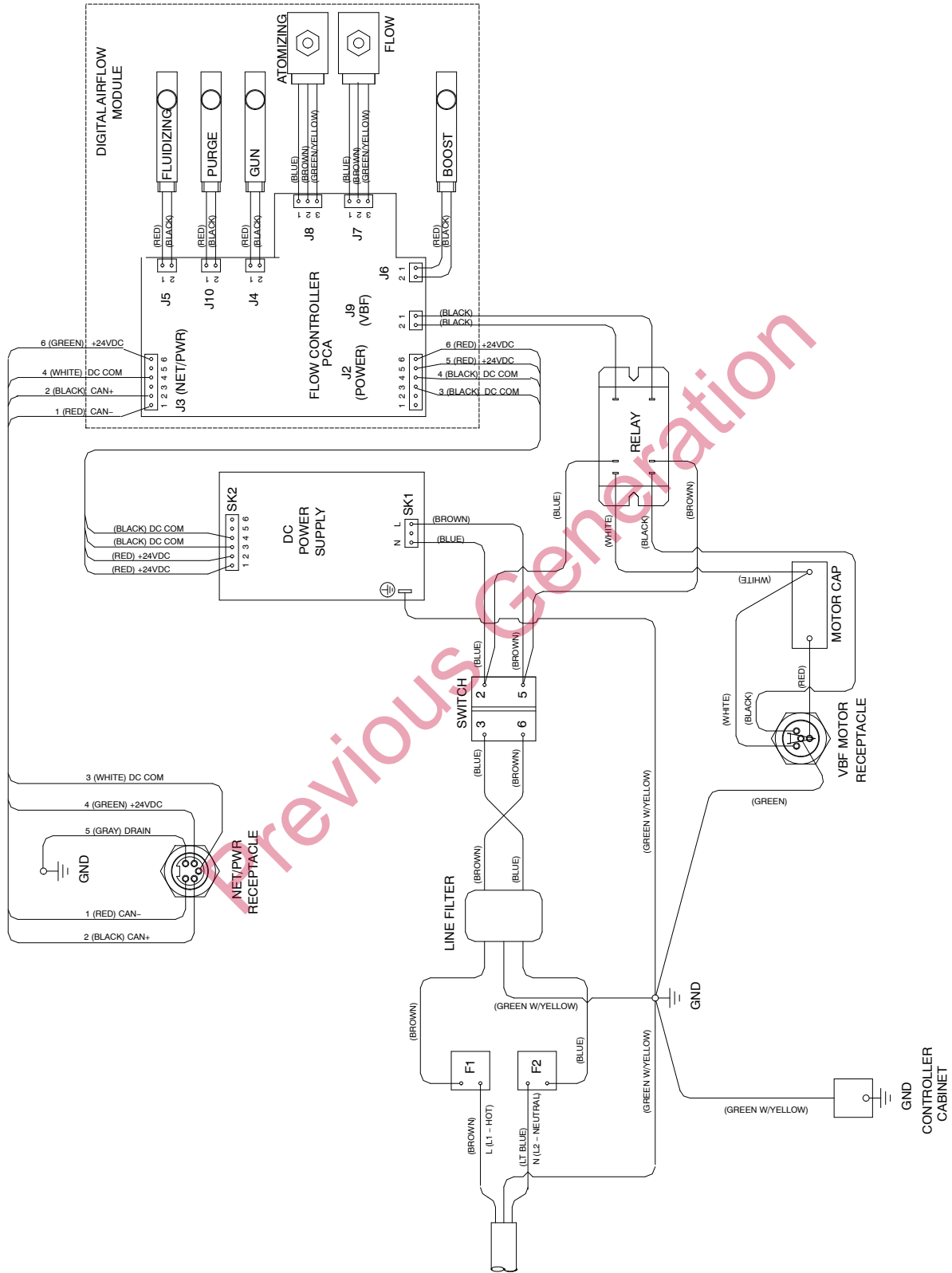

Figure 5-6 Power Unit Wiring Diagram

Controller Interface Wiring

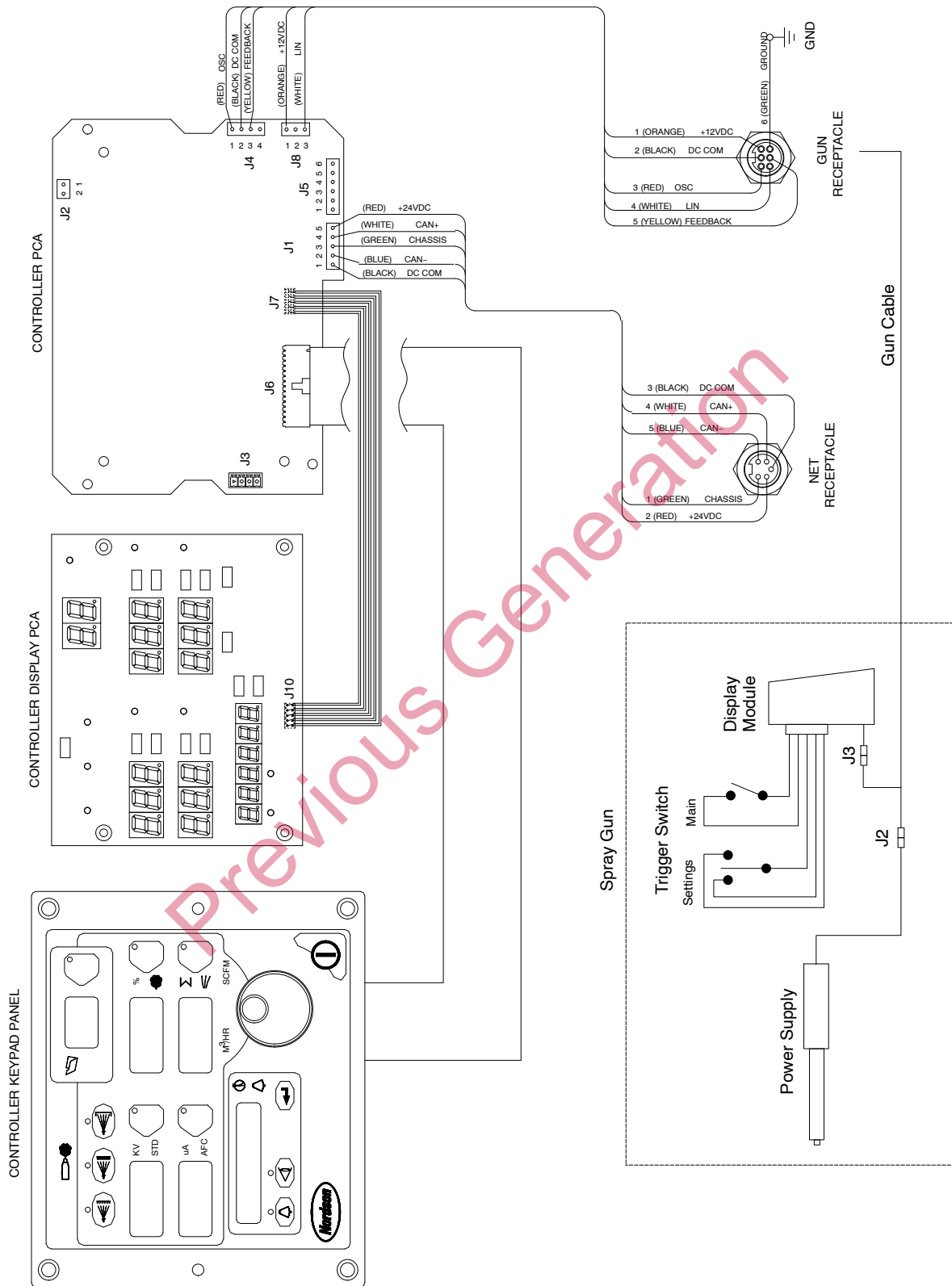

Figure 5-7 Controller Interface Wiring Diagram

Previous Generation

Section 6

Repair



WARNING: Allow only qualified personnel to perform the following tasks. Follow the safety instructions in this document and all other related documentation.

Spray Gun Repair

Item numbers in this section match the item numbers in the parts lists.

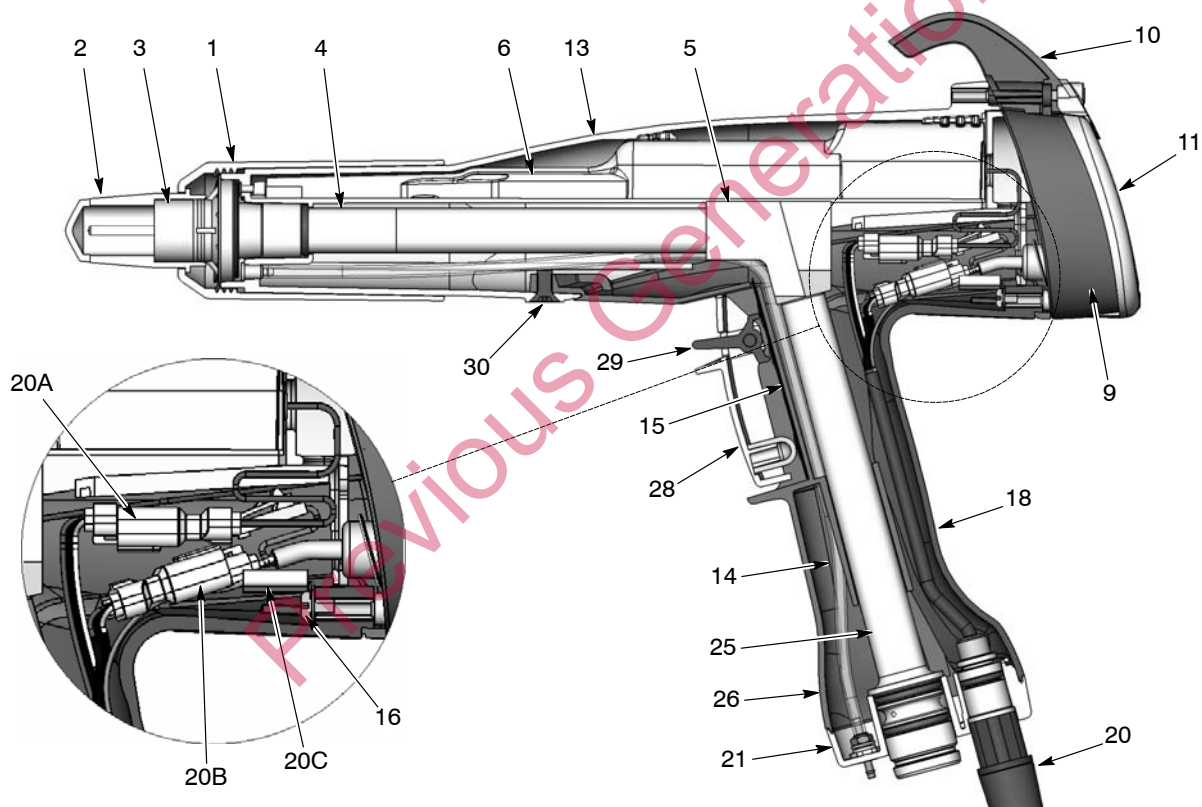

Figure 6-1 Section View of Spray Gun (item numbers in this section match item numbers in parts list)

- | | | |
|-----------------------|----------------------------------|--------------------------------|
| 1. Nozzle nut | 11. Bezel | 20B. Display connector (J3) |
| 2. Nozzle | 13. Gun body | 20C. Ground terminal (J1) |
| 3. Electrode assembly | 14. Air wash tubing | 21. Handle base |
| 4. Outlet tube | 15. Trigger switch | 25. Inlet tube |
| 5. Elbow | 16. Ground screw | 26. Handle |
| 6. Power supply | 18. Ground pad | 28. Spray trigger |
| 9. Display module | 20. Cable assembly | 29. Settings/purge trigger |
| 10. Hook | 20A. Power supply connector (J2) | 30. Screw (handle to gun body) |

Note: Ground terminal (20C) must always be connected to the ground screw (16).

Display Module Replacement

Display Module Removal

1. See Figures 6-1 and 6-2. Unscrew the top and bottom screws (12) holding the bezel (11), hook (10) and display module (9) onto the gun body.
2. Remove the bezel and slide the hook off the display module.
3. Carefully pull the display module away from the gun.
4. Insert a small screwdriver into the recess in the J3 gun cable/display module connectors to release the catch and disconnect them.
5. Carefully remove the adhesive support pad and the trigger switch header from the display module.
6. If the adhesive support pad remains stuck to the trigger switch header, carefully peel the pad off. Both the display module kit and trigger switch kit include new adhesive support pads.

Display Module Installation

1. On the display module (9), carefully clean the trigger switch header mounting surface and surrounding area with isopropyl alcohol. Allow the surface to dry completely before proceeding.
2. If you are installing a new trigger switch, remove the two liners from the connector side of the trigger switch header as shown in Figure 6-2.
3. Align the trigger switch header with the display module receptacle and push on the header to connect it. Apply even pressure on the header to seal it tightly against the display module.
4. Remove the liner from the new adhesive support pad and install it over the trigger switch header. Apply even pressure on the support pad to seal it to the display module.
5. Connect the J3 display module and cable connector together. The ground wire connector (A) is not used for this version of the gun.
6. Gently fold the trigger switch ribbon cable and display module cable into the gun, and install the display module onto the gun.
7. Slide the hook (10) onto the display module, then install the bezel (11).
8. Install and tighten the screws (12).

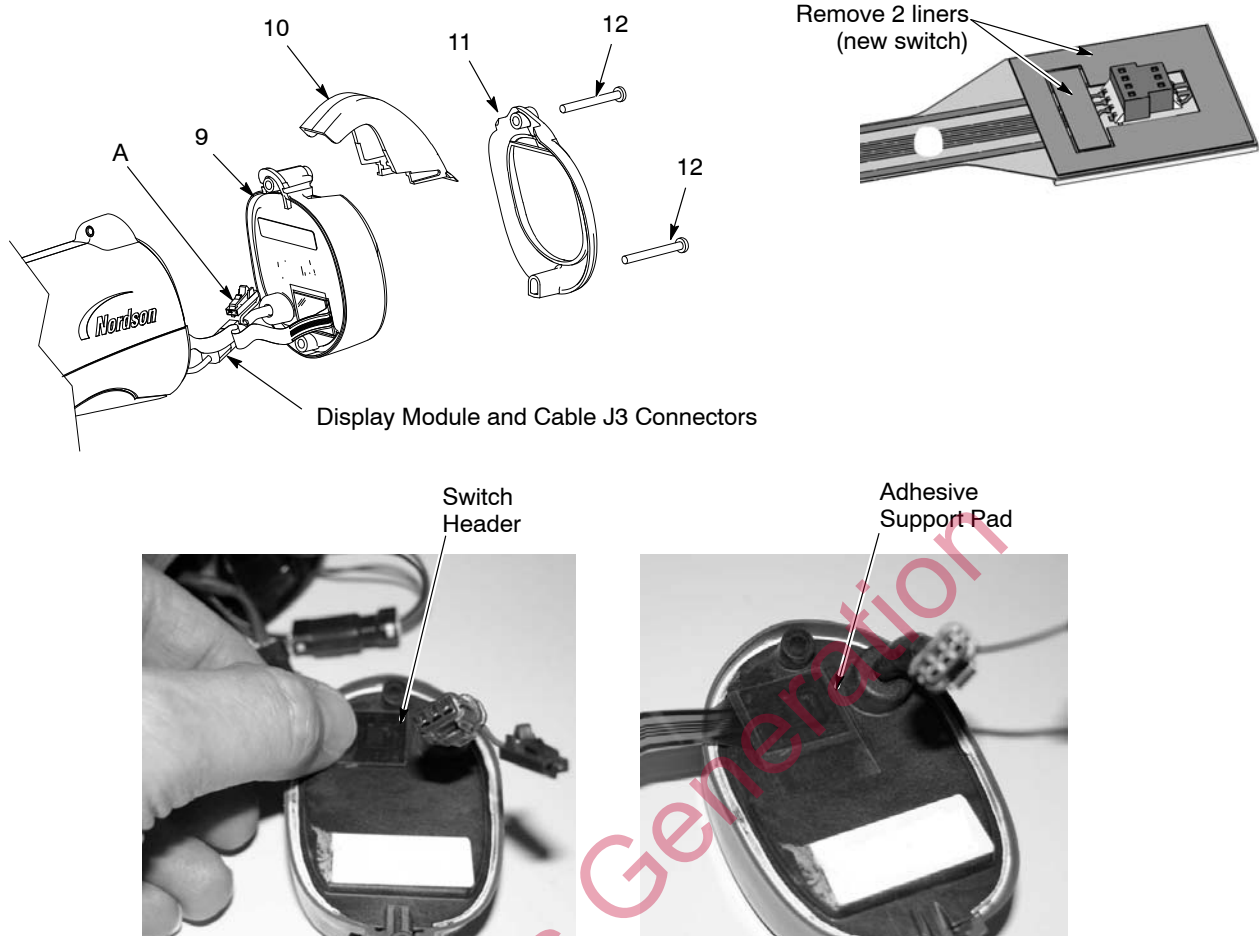

Figure 6-2 Display Module Replacement

9. Display module
10. Hook

11. Bezel
12. M3 x 35 screws

A. Ground wire connector

Power Supply and Powder Path Replacement

Gun Disassembly

1. Remove the display module from the spray gun as described in *Display Module Replacement* on page 6-2.
2. See Figure 6-1. Unscrew the nozzle nut and remove the nozzle and electrode assembly from the spray gun.
3. Insert a small screwdriver into the recess in the J2 gun cable/power supply connectors to release the catch and disconnect them.
4. See Figure 6-3. Remove the black nylon screw (30) from the gun body.
5. Grasp the handle in one hand and the gun body in the other. Press the thumbs of each hand together while pulling carefully in opposite directions to separate the gun body from the handle. The air wash tubing will prevent a complete separation; leave it connected unless it must be replaced.

Gun Disassembly (contd)

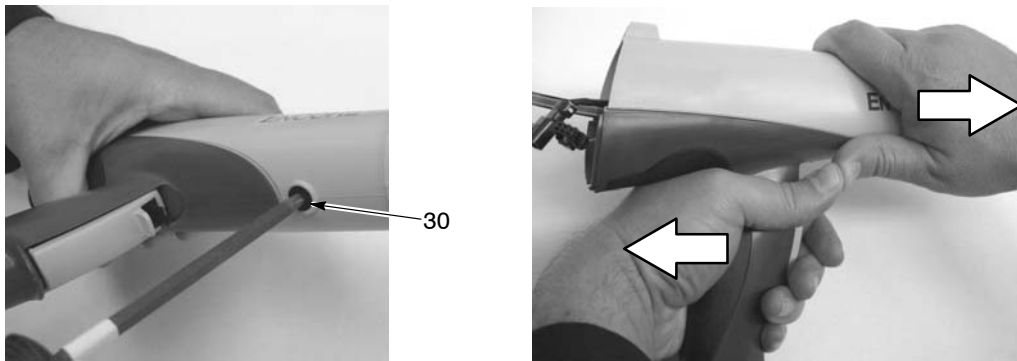

Figure 6-3 Removing the Gun Body from the Handle

Power Supply Replacement

NOTE: If replacing the powder path, skip this procedure.

1. See Figure 6-4. Slide the power supply (6) out of the gun body.
2. Check the gasket (7) on the back of the bulkhead (8). Replace it if it is damaged. The gasket is stuck to the bulkhead with pressure-sensitive adhesive.

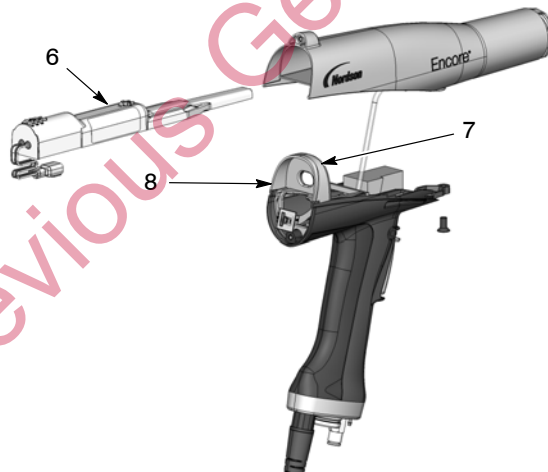

Figure 6-4 Removing the Power Supply from the Gun Body

3. Slide the new power supply into the upper cavity of the gun body, guiding the gun body ribs between the raised grooves on the top of the power supply.
4. Press on the end of the power supply to ensure that the power supply contact tip is firmly seated against the brass contact inside the gun body.
5. Route the power supply harness connector through the top hole in the bulkhead.

Powder Path Replacement

NOTE: Skip these steps if not replacing the powder path. Go to page 6-6 to reassemble the spray gun.

1. Perform the *Gun Disassembly* procedure on page 6-3.
2. See Figure 6-5. Remove the elbow (5) from the inlet tube (25).
3. Remove the two M3 x 20 screws (22) from the handle base (21).
4. Pull the base away from the handle, then swing the bottom of the ground pad (18) up and away from the handle, then remove it. Leave the ground wire connected to the ground pad.
5. Push the inlet tube (25) up and out of the base, then move the base out of the way and pull the inlet tube out of the handle.
6. Push the outlet tube (4) out of the front of the gun body (13).
7. Blow off the inlet tube, outlet tube, and elbow, and replace them if the interiors are worn or coated with impact-fused powder. If re-using the tubes, make sure the O-rings are undamaged.

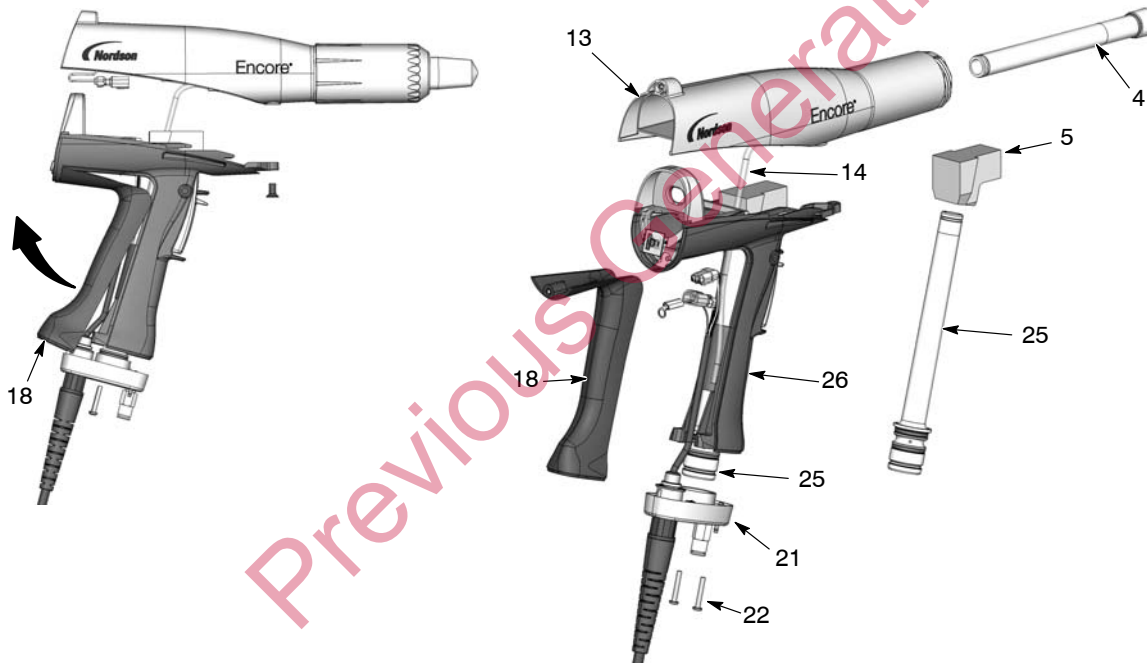

Figure 6-5 Powder Path Replacement

- | | | |
|----------------|---------------------|--------------------|
| 4. Outlet tube | 14. Air wash tubing | 22. M3 x 20 screws |
| 5. Elbow | 18. Ground pad | 25. Inlet tube |
| 13. Gun body | 21. Handle base | 26. Handle |

Powder Path Installation

1. See Figure 6-5. Install the outlet tube (4) into the gun body (13), with the end of the tube flush with the end of the gun body.
2. Install the inlet tube (25) into the handle (26), then install the end of the tube into the handle base (21).

Powder Path Installation *(contd)*

3. Push the handle base close to the handle, then hook the top end of the ground pad (18) into the body and rotate it onto the handle. Make sure the cable wires are not pinched or trapped during re-assembly.
4. Install the handle base onto the handle and ground pad and secure it with the two M3 x 20 screws (22).
5. Install the elbow (5) onto the inlet tube, with the end oriented toward the front of the gun as shown.

Gun Re-assembly

1. See Figure 6-6. Align the gun body with the handle and slide them together, engaging the internal ribs of the gun body with the handle tabs.

NOTE: Make sure that the power supply harness is not pinched between the bulkhead and the power supply.

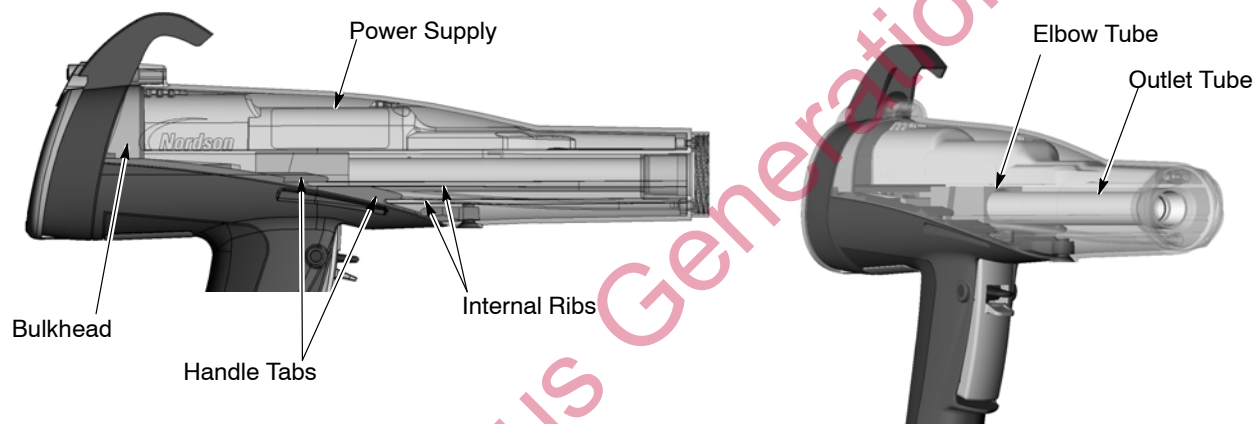

Figure 6-6 Gun Re-assembly

2. Insert your finger into the outlet tube at the front of the gun and align the inside end of the tube with the elbow, then push on the tube to seat it in the elbow.
3. Connect the power supply harness to the gun cable, then tuck both through the bottom hole in the bulkhead, into the gun body.
4. See Figure 6-2. Install the display module as described in *Display Module Installation* on page 6-2.
5. Install the electrode assembly (3) into the the end of the outlet tube at the front of the gun body. Make sure the wire electrode is not bent or broken.
6. Install the nozzle (2) on the electrode assembly, making sure the keys in the electrode assembly slide into the slots on the nozzle.
7. Install the nozzle nut (1) over the nozzle and rotate clockwise to secure.

Cable Replacement

Cable Removal

1. Disconnect the gun cable from the controller.
2. See Figure 6-7, View A. Remove the two M3 x 20 screws (22) securing the handle base (21) to the handle.
3. Remove the lower M3 x 35 screw (12) from the display module.
4. Pull the base away from the handle enough to free the bottom edge of the ground pad (18) from the base.
5. Pull the bottom edge of the ground pad out and away from the handle.
6. See Figure 6-7, View B. Remove the M3 x 6 screw, lock washer (16, 17), and ground terminal from the ground pad.
7. Remove the retaining ring (19) from the cable.
8. See Figure 6-7, View C. Pull the cable connectors out of the handle. Insert a small flat-bladed screw driver in the slots of the power supply and display connectors to release the catch and disconnect them.
9. Pull the cable out of the handle base, feeding the connectors through the base one at a time.

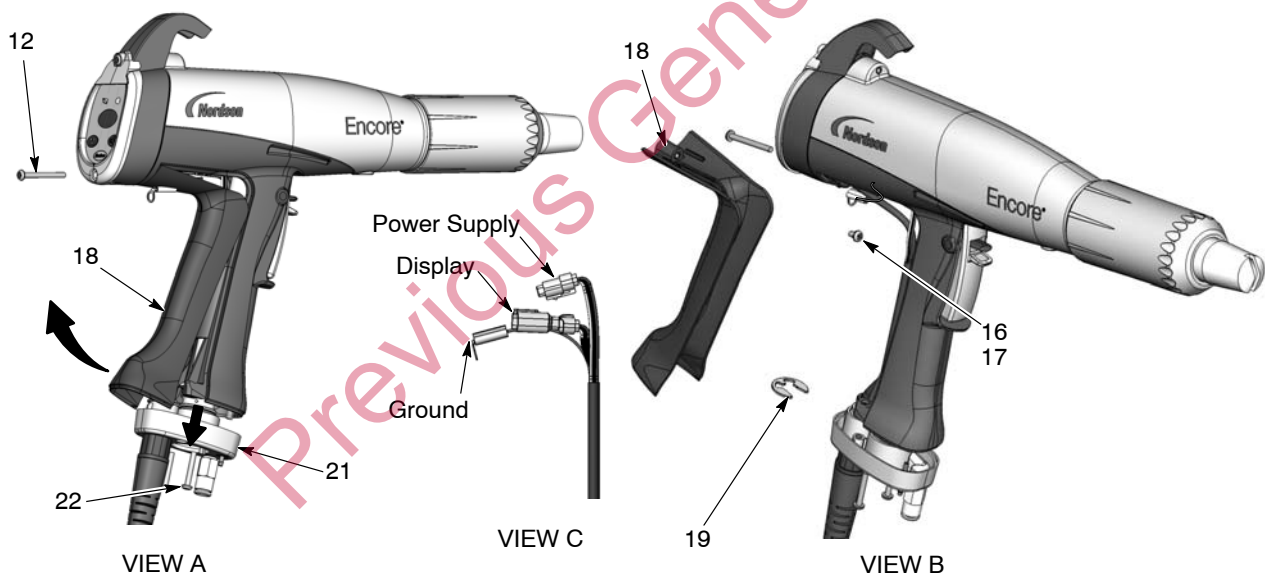

Figure 6-7 Cable Replacement

12. M3 x 35 screw
16. M3 x 6 screw

17. Lock washer
18. Ground pad

19. Retaining ring
21. Handle base
22. M3 x 20 screws

Cable Installation

1. See Figure 6-7. Feed a new cable through the handle base, then install the retaining ring (19) on the cable to hold it in place.
2. Connect the cable to the display module and power supply connectors.

Cable Installation *(contd)*

3. Connect the cable terminal to the ground pad (18) with the M3 x 6 screw and lock washer (16, 17).
4. Tuck the cable connectors and ground wire into the gun, below the multiplier.
5. Hook the top of the ground pad into the gun body, then rotate it into position on the handle.
6. Push the handle base (21) up against the handle and ground pad, and tighten securely the two M3 x 20 screws (22) in the base.
7. Re-install the M3 x 35 screw (12) in the bottom of the display module.

Trigger Switch Replacement**Switch Removal**

1. Remove the display module and disconnect the trigger switch ribbon cable from the module as described in Display Module Removal on page 6-2.
2. Remove the gun body from the handle as described in Gun Disassembly on page 6-3.
3. See Figure . Pull out the elbow (5) off the inlet tube.
4. Push the small diameter end of the axle (31) out of the handle with a small, flat-ended punch or other tool.
5. Remove the spray trigger (28), actuator (27), and purge trigger (29) from the handle.
6. Use a tool to pry and pull the trigger switch (15) off the handle, then pull it up and out of the handle.

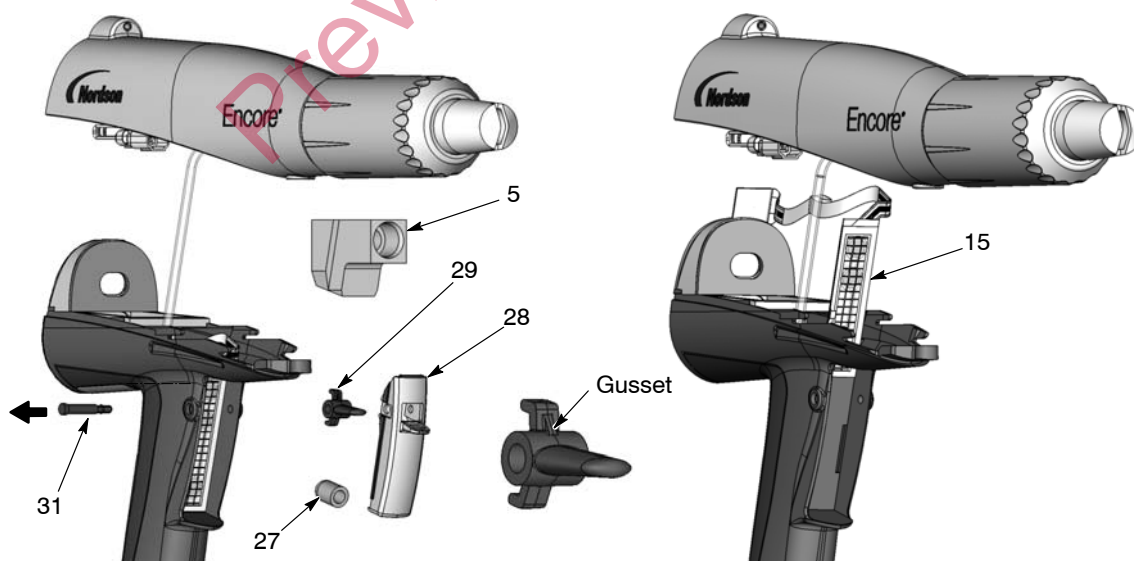

Figure 6-8 Trigger Switch Replacement

Switch Installation

1. See Figure 6-8. Orient the new switch (15) with the grid facing the front of the gun, then carefully feed the square, bottom end of the switch through the slot in the handle.
2. Peel the adhesive release liner from the back of the switch.
3. Carefully install the switch against the bottom and left edges of the trigger recess, pressing the switch against the back of the recess. Run your finger up and down on the switch to ensure it is securely adhered to the handle.
4. Install the purge trigger (29) into the spray trigger (28) with the gusset oriented upward as shown. **Do not install the purge trigger upside down.**
5. Position the triggers in the handle and hold them in place while pressing the axle (31) through the handle and triggers until the head of the axle is flush with the handle. The axle will snap into place when properly installed.
6. Feed the trigger switch ribbon cable through the bottom of the bulkhead and connect the ribbon cable connector to the display module as described in *Display Module Installation* on page 6-2.
7. Re-assemble the gun as described in *Gun Re-assembly* on page 6-6.

Interface Module Repair



WARNING: Shut off the controller and disconnect the power cord or disconnect and lock out power at a breaker or disconnect ahead of the controller before opening the controller enclosures. Failure to observe this warning could result in a severe electrical shock and personal injury.



CAUTION: Electrostatic sensitive device. To avoid damaging the controller circuit boards, wear a grounding wrist strap and use proper grounding techniques when making repairs.

Refer to *Section 5, Troubleshooting*, for the interface electrical schematic and harness connections. Refer to *Section 7, Parts* for repair kits.

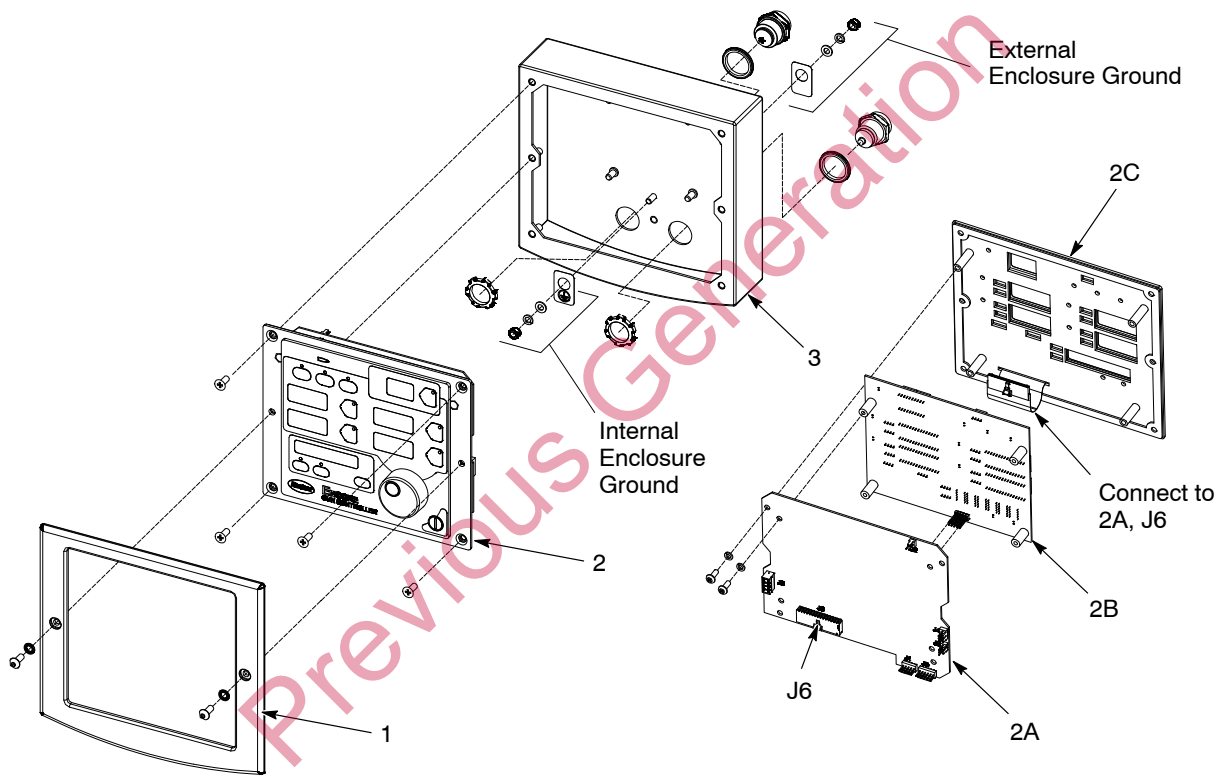

Figure 6-9 Interface Module Assembly

- | | | |
|------------------------|------------------------|------------------|
| 1. Bezel | 2A. Main Control Board | 2C. Keypad Panel |
| 2. Keypad/PCB Assembly | 2B. Main Display Board | 3. Enclosure |

Power Unit Repair



WARNING: Shut off the controller and disconnect the power cord or disconnect and lock out power at a breaker or disconnect ahead of the controller before opening the controller enclosures. Failure to observe this warning could result in a severe electrical shock and personal injury.



CAUTION: Electrostatic sensitive device. To avoid damaging the controller circuit boards, wear a grounding wrist strap and use proper grounding techniques when making repairs.

Refer to *Section 5, Troubleshooting*, for the power unit electrical schematic and harness connections.

Removing the Sub-Panel

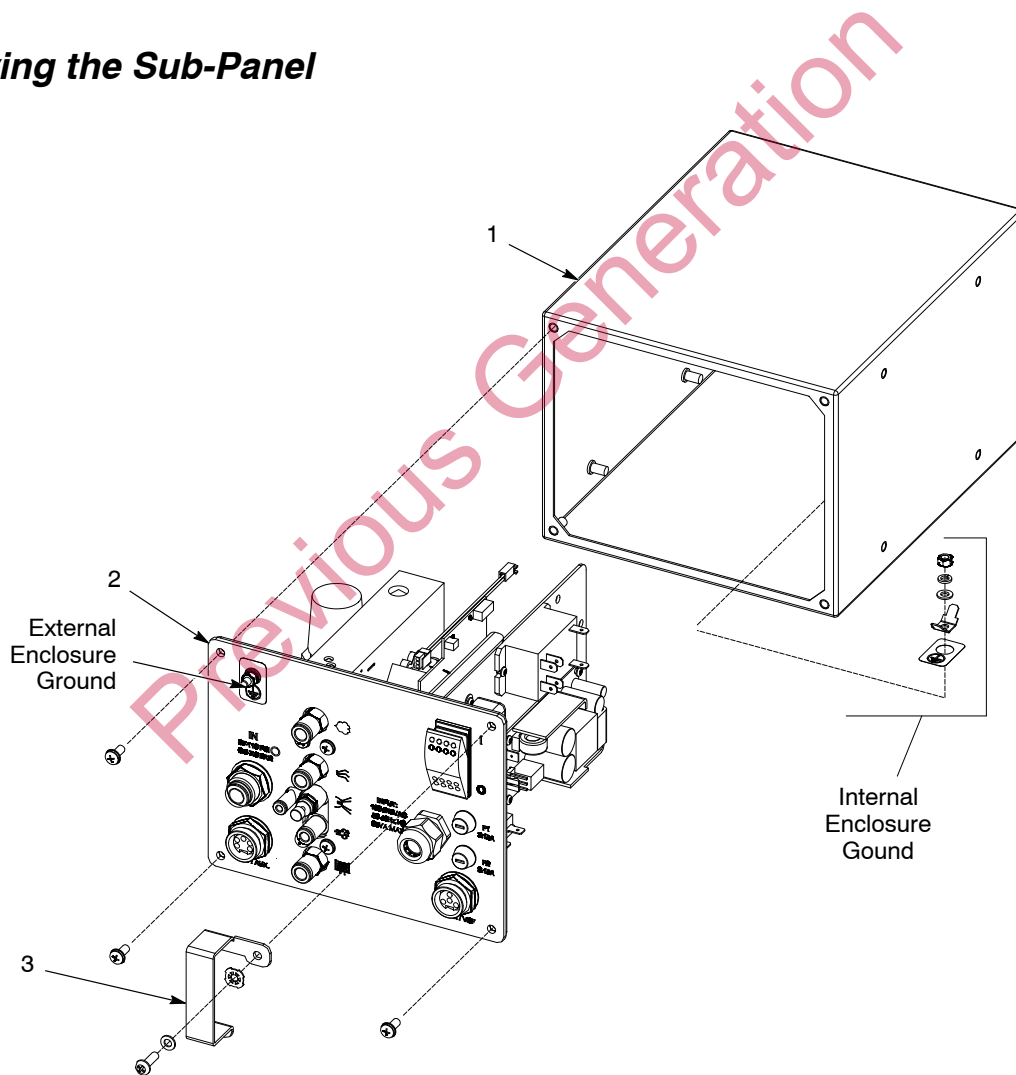

Figure 6-10 Sub-Panel Removal

1. Enclosure

2. Sub-Panel

3. Power Switch Guard

Sub-Panel Components

Figure 6-11 is an exploded view of the components of the sub-panel. The major replaceable parts are called out. Refer to the following when making repairs:

- *Section 7, Parts* for parts and service kits.
- *Section 5, Troubleshooting*, for wiring diagrams and circuit board connections.
- *Regulator Replacement* and *iFlow Module Repair* for repair procedures.

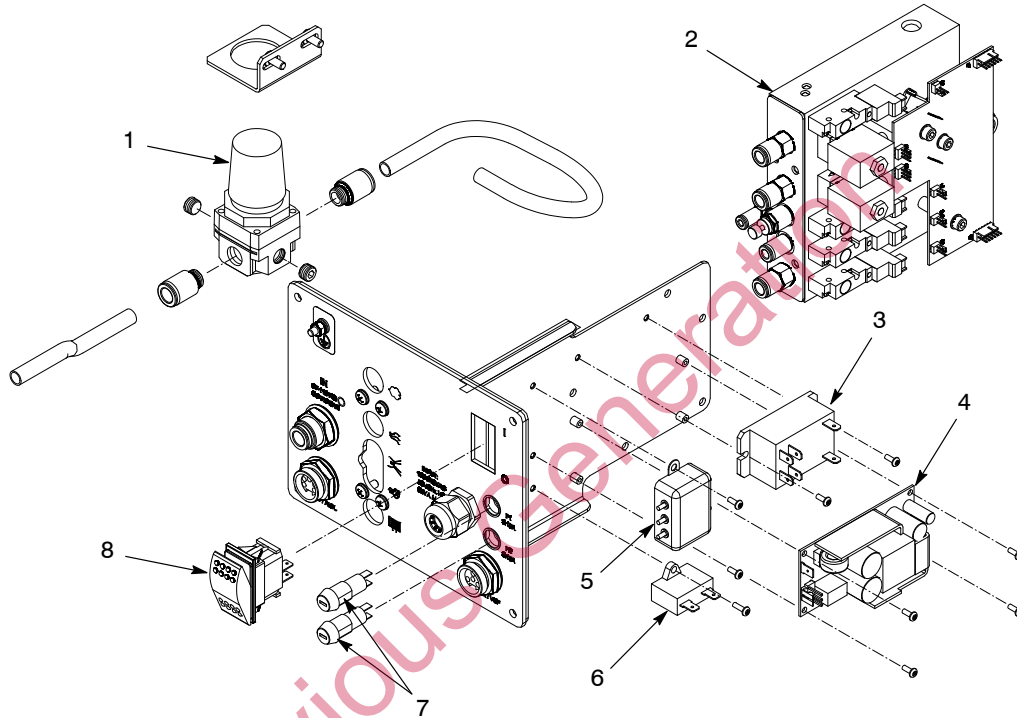

Figure 6-11 Sub-Panel Parts Replacement

- | | | |
|-----------------|--------------------|---------------------------|
| 1. Regulator | 4. Power supply | 7. Fuses and fuse holders |
| 2. iFlow module | 5. Line filter | 8. Rocker switch |
| 3. Relay (VBF) | 6. Capacitor (VBF) | |

Regulator Adjustment

If you replace the precision regulator in the power unit, you must adjust it using the iFlow Air Verification Kit and this procedure.

NOTE: The plugs and connectors in the regulator ports are not supplied with a new regulator. Install the plugs and connectors from the old regulator in the new regulator.

1. See Figure 6-12. Pull the sub-panel (7) far enough out of the power unit cabinet to access the regulator.

2. Disconnect the 4-mm electrode air wash tubing from the power unit. Disconnect the flow, atomizing, purge, and fluidizing air tubing and plug the fittings with 8-mm and 6-mm plugs (6).
3. Unplug the 4-mm manometer air tubing (2) from the orifice assembly (1) and plug the tubing to the electrode air wash fitting (4).
4. On the controller interface, set the flow-rate and atomizing air flows to 1 SCFM (1.70 m³/h).
5. Point the spray gun into the booth and trigger the gun on. The manometer should show a pressure reading.
6. Pull out the regulator knob (5) and adjust it to slightly more than 85 psi (5.86 bar). The manometer reading should occasionally bounce higher, but never fall below 85.
7. Push in the regulator knob to lock the setting, slide the sub-panel back into the enclosure and secure it with the screws in each corner, and re-connect the flow, atomizing, purge, fluidizing, and air wash tubing.

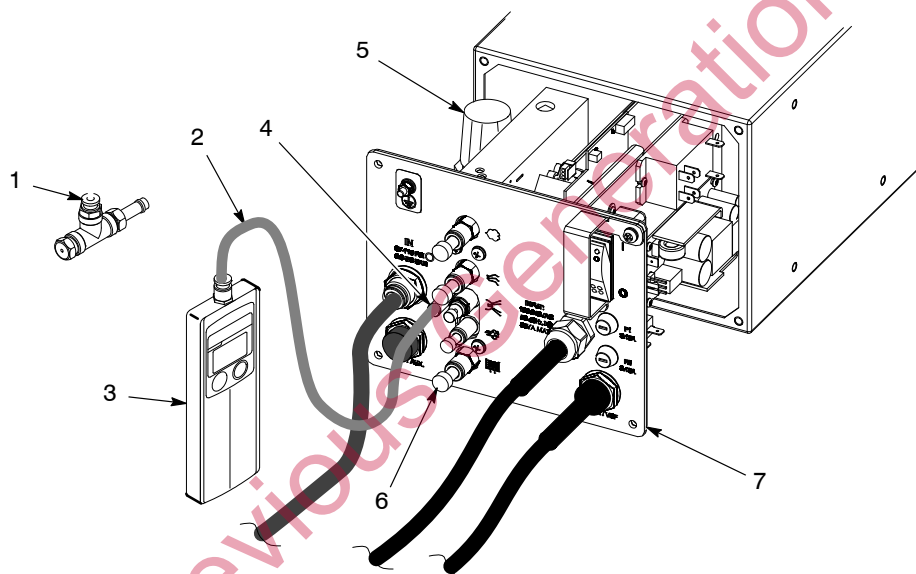

Figure 6-12 Regulator Adjustment

- | | | |
|----------------------|---------------------|----------------------|
| 1. Orifice assembly | 4. Air wash fitting | 6. Air fitting plugs |
| 2. 4-mm clear tubing | 5. Regulator | 7. Sub-panel |
| 3. Manometer | | |

iFlow Module Repair

The iFlow module consists of a circuit board and air manifold, on which are mounted two proportional valves, transducers, and four solenoid valves. Repair of the flow module is limited to cleaning or replacing the proportional valves, and replacing the solenoid valves, check valves, and fittings.



CAUTION: The module circuit board is an electrostatic sensitive device (ESD). To prevent damage to the board when handling it, wear a grounding wrist strap connected to ground. Handle the board only by its edges.

Testing iFlow Modules

Use the iFlow Air Flow Verification Kit to check the output of the proportional valves for correct air flow output. Use the following procedure:



CAUTION: Handle the orifice assembly with care. Rough handling can damage the orifice and affect the manometer reading.

1. Disconnect the air tubing from the flow or atomizing air fitting and plug in the orifice assembly.
2. Set the controller Powder Flow mode to Classic Flow, then set the flow of the function (flow or atomizing air) you are checking to the lowest value in the *Flow to Pressure* chart on page 6-15.
3. Turn on the manometer. If desired, change the scale to read bar instead of psi. Refer to manometer documentation for instructions.
4. Point the spray gun into the booth and trigger the gun on.
5. Refer to the *Flow to Pressure* chart on the following page to compare the manometer reading with the min/max acceptable range.

Check the output pressure at different flow settings. If the manometer reading is within the acceptable range then the digital flow module is working correctly. If the reading is not within the acceptable range refer to the Troubleshooting procedures in *Section 4, Troubleshooting*.

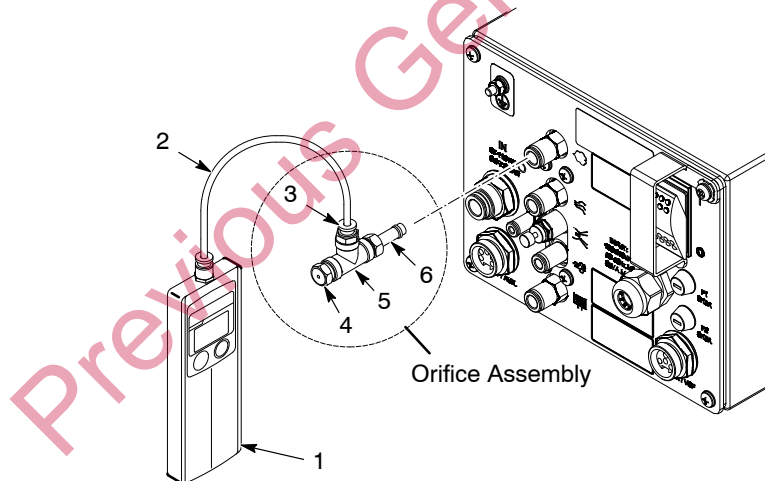

Figure 6-13 Air Verification Kit Usage

- | | |
|------------------------|--------------|
| 1. Manometer | 4. Orifice |
| 2. Clear 4-mm tubing | 5. Tee |
| 3. 4-mm tube connector | 6. 8-mm stem |

Testing iFlow Modules *(contd)*

Flow to Pressure Chart		
Air Flow Setting m ³ /hr (scfm)	Manometer Reading Minimum bar (psi)	Manometer Reading Maximum bar (psi)
0.00	0	0
0.85 (0.50)	0.1 (1)	0.2 (3)
1.25 (0.75)	0.1 (2)	0.3 (5)
1.65 (1.00)	0.3 (5)	0.5 (7)
2.10 (1.25)	0.5 (8)	0.7 (10)
2.50 (1.50)	0.8 (11)	1.0 (14)
2.95 (1.75)	1.0 (14)	1.2 (17)
3.35 (2.00)	1.2 (18)	1.5 (21)
3.75 (2.25)	1.4 (21)	1.7 (24)
4.20 (2.50)	1.7 (25)	1.9 (28)
4.60 (2.75)	2.0 (29)	2.2 (32)
5.05 (3.00)	2.3 (33)	2.5 (36)
5.50 (3.25)	2.5 (37)	2.8 (40)
5.95 (3.50)	2.8 (41)	3.0 (44)
6.35 (3.75)	3.0 (45)	3.3 (48)
6.80 (4.00)	3.4 (49)	3.6 (52)

Solenoid Valve Replacement

See Figure 6-14. To remove the solenoid valves (13), remove the two screws in the valve body and lift the valve off the manifold.

Make sure the O-rings furnished with the new valves are in place before installing the new valve on the manifold.

Proportional Valve Cleaning

See Figure 6-14. A dirty air supply can cause the proportional valve (6) to malfunction. Follow these instructions to disassemble and clean the valve.

1. Disconnect the coil (3) wiring from the circuit board (1). Remove the nut (2) and coil from the proportional valve (6).
2. Remove the two long screws (4) and two short screws (5) to remove the proportional valve from the manifold.



CAUTION: The valve parts are very small; be careful not to lose any. Do not mix the springs from one valve with those from another. The valves are calibrated for different springs.

3. Remove the valve stem (8) from the valve body (11).

4. Remove the valve cartridge (10) and spring (9) from the stem.

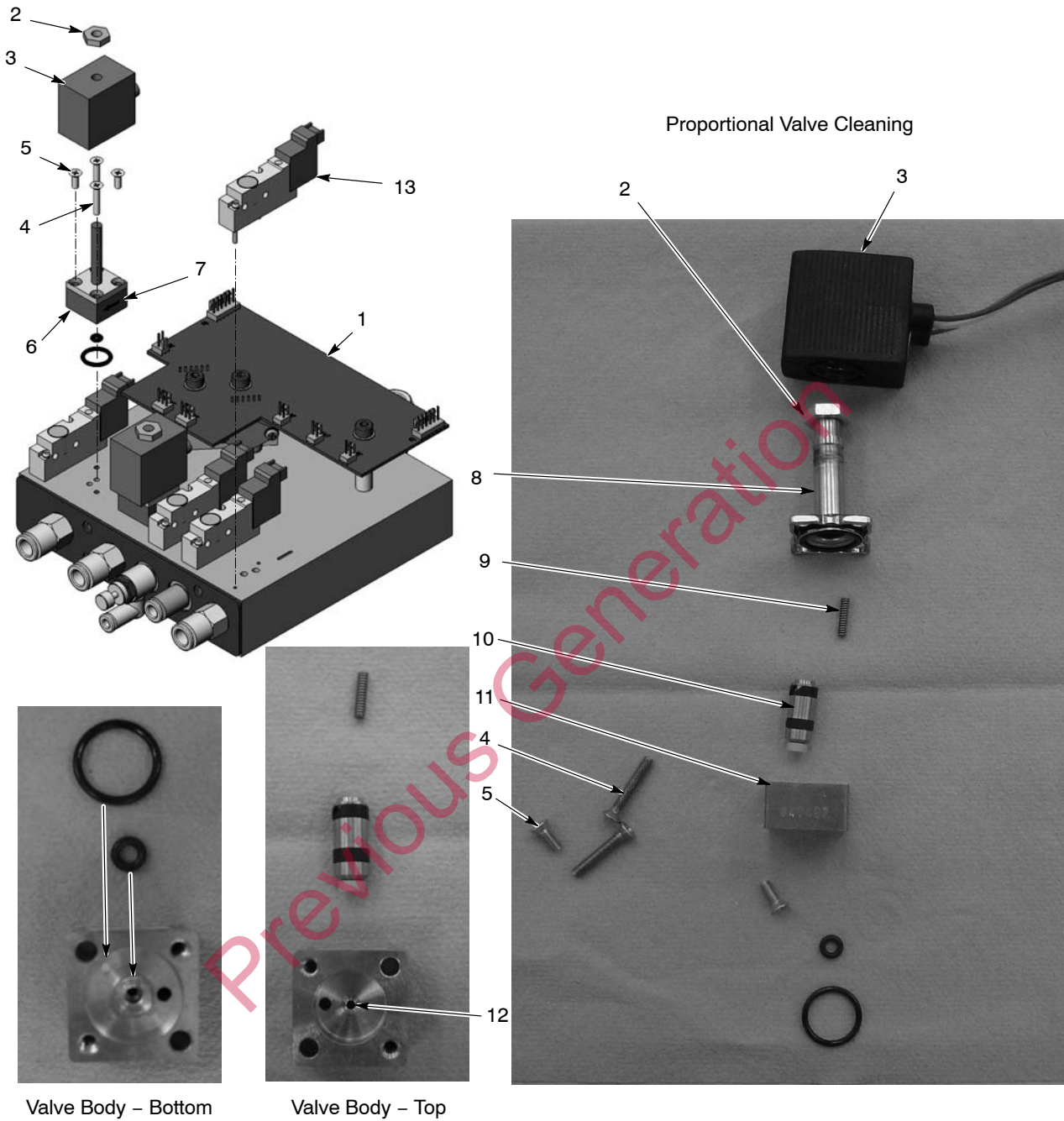

Figure 6-14 iFlow Module Repair – Solenoid Valve Replacement and Proportional Valve Cleaning or Replacement

- | | | |
|--|----------------------------|---------------------|
| 1. Circuit board | 6. Proportional valve (2) | 10. Cartridge |
| 2. Nut-coil to proportional valve (2) | 7. Direction of flow arrow | 11. Valve body |
| 3. Coil-proportional valve (2) | 8. Stem | 12. Orifice |
| 4. Long screws-valve to manifold (2) | 9. Spring | 13. Solenoid valves |
| 5. Short screws-valve stem to body (2) | | |

Proportional Valve Cleaning (contd)

5. Clean the cartridge seat and seals, and the orifice in the valve body. Use low-pressure compressed air. Do not use sharp metal tools to clean the cartridge or valve body.
6. Install the spring and then the cartridge in the stem, with the plastic seat on the end of the cartridge facing out.
7. Make sure the O-rings furnished with the valve are in place on the bottom of the valve body.
8. Secure the valve body to the manifold with the long screws, making sure the arrow on the side of the body points toward the outlet fittings.
9. Install the coil over the valve stem, with the coil wiring pointing toward the circuit board. Secure the coil with the nut and connect the coil wiring to the circuit board.

Proportional Valve Replacement

See Figure 6-14. If cleaning the proportional valve does not correct the flow problem then replace the valve. Before installing a new valve, remove the protective cover from the bottom of the valve body. Be careful to not lose the O-rings under the cover.

Vibrator Motor Replacement

When replacing the vibrator motor, make sure you order the correct motor for your voltage. Check the ID plate on the power unit. Replacement motors include the power cable.

Refer to the *Power Unit Wiring Diagram* in the *Troubleshooting* section of this manual for internal VBF wiring.

Previous Generation

Section 7

Parts

Introduction

To order parts, call the Nordson Industrial Coating Systems Customer Support Center at (800) 433-9319 or contact your local Nordson representative.

This section covers components, parts and options for the Encore LT spray gun, controller, and systems.

Refer to the following manuals for additional information and optional equipment.

Encore Manual System Operator Card: 1088668
Encore Generation II Powder Feed Pump: 1095927
Encore 150, 300, and 600-mm Lance Extensions: 1093657
Pattern Adjuster Kit for Lance Extensions: 1100013
Pattern Adjuster Kit for Encore Manual Spray Guns: 10984490
Encore Cup Gun Kit: 1102764

These manuals can be downloaded from:
<http://emanuals.nordson.com/finishing/>
 (click on Powder-US, then Encore Systems)

System Part Numbers

Use these part numbers to order complete systems.

Part	Description	Note
1600827	SYSTEM, mobile powder, 115V VBF, Encore XT	
1600828	SYSTEM, mobile powder, 220V VBF, Encore XT	
1600829	SYSTEM, mobile powder, 50-lb hopper, Encore XT	
1600830	SYSTEM, mobile powder, 25-lb hopper, Encore XT	
1600831	SYSTEM, rail mount, Encore XT, 230V	
1600821	SYSTEM, rail mount, Encore XT, 115V	
1600832	SYSTEM, wall mount, Encore XT, 230V	
1600822	SYSTEM, wall mount, Encore XT, 115V	

Spray Gun Parts

See Figure 7-1 and the parts list on the following pages.

Spray Gun Parts List

See Figure 7-1.

Item	Part	Description	Quantity	Note
-	1600818	HANDGUN assembly, Encore XT	1	
1	1081638	• NUT, nozzle, handgun	1	
2	1081658	• NOZZLE, flat spray, 4 mm	1	A
3	1106076	• ELECTRODE ASSEMBLY, packaged	1	
3A	1106078	• • ELECTRODE, spring contact, packaged	1	
3B	1106071	• • HOLDER, electrode, M3, Encore	1	
4	1085024	• KIT, powder outlet tube, Encore	1	D
4B	1081785	• • O-RING, silicone, 0.468 x 0.568 x 0.05 in.	1	
4A	941113	• • O-RING, silicone, 0.438 x 0.625 x 0.094 in.	1	
5	1096695	• ELBOW, powder tube, handgun	1	D
6	1084821	• POWER SUPPLY, 100 kV, negative, Encore, packaged	1	
7	1088502	• GASKET, multiplier cover, handgun	1	
8	1106872	• BULKHEAD, multiplier, handgun, Encore LT/XT	1	
9	1100986	• KIT, handgun display module, Encore	1	
NS	1085361	• • SUPPORT, adhesive, handgun, Encore	1	
10	1087760	• HOOK, handgun	1	
11	1102648	• BEZEL, shield, plated	1	
12	345071	• SCREW, pan head, recessed, M3 x 35, BZN	2	
13	1088506	• KIT, body assembly, handgun, Encore	1	
14	1088558	• FILTER ASSEMBLY, handgun	1	
15	1101872	• KIT, trigger switch, Encore	1	
NS	1085361	• • SUPPORT, adhesive, handgun, Encore	1	
16	983520	• WASHER, lock, internal, M3, zinc	1	
17	982427	• MACHINE SCREW, pan head, recessed, M3 x 6, zinc	1	
18	1106871	• HANDLE, ground pad, handgun, Encore LT/XT	1	
19	1081777	• RETAINING RING, external, 10 mm	1	
20	1600745	• CABLE ASSY, handgun, 6 meter, Encore XT	1	E
20A	940129	• • O-RING, silicone, conductive, 0.375 x 0.50in.	1	
21	1087762	• BASE, handle, handgun	1	
22	760580	• SCREW, Philips head, M3 x 20, zinc	2	
23	1081617	• CHECK VALVE, male, M5 x 6 mm	1	
24	1081616	• FITTING, bulkhead, barb, dual, 10-32 x 4 mm	1	
25	1085026	• KIT, powder inlet tube, Encore	1	
25A	1084773	• • O-RING, silicone, 18 mm ID x 2 mm wide	2	
25B	1081785	• • O-RING, silicone, 0.468 x 0.568 x 0.05 in.	1	
26	1600819	• HANDLE, handgun, Encore XT	1	
27	1106892	• ACTUATOR, switch, trigger, Encore LT/XT	1	
28	1106873	• TRIGGER, main, handgun, Encore LT/XT	1	
29	1081540	• TRIGGER, setting, handgun	1	
30	1088601	• SCREW, flat head, recess, M5x 10, nylon	1	
31	1106875	• AXLE, trigger, handgun, Encore XT	1	

Continued...

7-4 Parts

Item	Part	Description	Quantity	Note
32	1083206	• DEFLECTOR assembly, conical, 26 mm	1	A
32A	1098306	• • O-RING, Viton, 3 mm x 1.1 mm wide	1	B
33	1082060	• NOZZLE, conical	1	A
34	1106200	• KIT, hose adapter, hose, spray gun, Encore	1	
34A	940157	• • O-RING, Viton, black, 0.563 x 0.688, 10415	2	
NS	900617	• TUBE, polyurethane, 4 mm OD, clear	AR	C
NS	900741	• TUBING, polyurethane, 6/4 mm, black	AR	C
NS	900620	• TUBING, poly, spiral cut, $\frac{3}{8}$ in. ID	AR	C
<p>NOTE A: 4-mm flat spray nozzle, conical nozzle and deflector, are shipped with the spray gun. Refer to the following pages for optional nozzles.</p> <p>B: This O-ring is a component of all deflectors.</p> <p>C: Order in increments of one foot or one meter.</p> <p>D: Also available in wear resistant material. Refer to <i>Spray Gun Options</i>.</p> <p>E: Optional 6 meter extension available; refer to <i>Spray Gun Options</i>.</p>				

Previous Generation

Spray Gun Options

Miscellaneous Spray Gun Options

See Figure 7-1.

Item	Part	Description	Quantity	Note
18	1096696	ELBOW, powder tube, Encore, impact resistant	1	
4	1096698	KIT, powder outlet tube, wear resistant	1	
4A	1081785	• O-RING, silicone, 0.468 x 0.568 x 0.05 in.	1	
4B	941113	• O-RING, silicone, 0.438 x 0.625 x 0.094 in.	1	
NS	1085168	CABLE, 6-wire, shielded, handgun, 6 meter extension	1	

NOTE A: This pattern adjuster kit is only for use with a lance extension. See page 7-7 for the standard pattern adjuster kit.
 NS: Not Shown

Flat Spray Nozzles

The 4-mm flat spray nozzle is shipped with the spray gun. All other flat spray nozzles are optional.

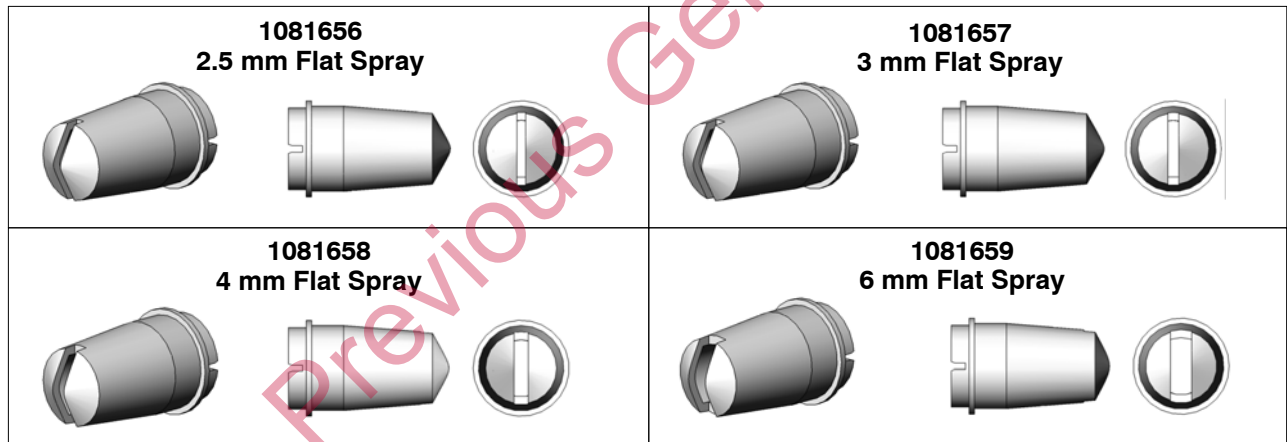

Figure 7-2 Flat Spray Nozzles

Conical Nozzle and Deflectors

A conical nozzle and 26-mm deflector is shipped with the spray gun. All other deflectors are optional.

NOTE: All deflectors include the O-ring, item 29A, listed in the spray gun parts list.

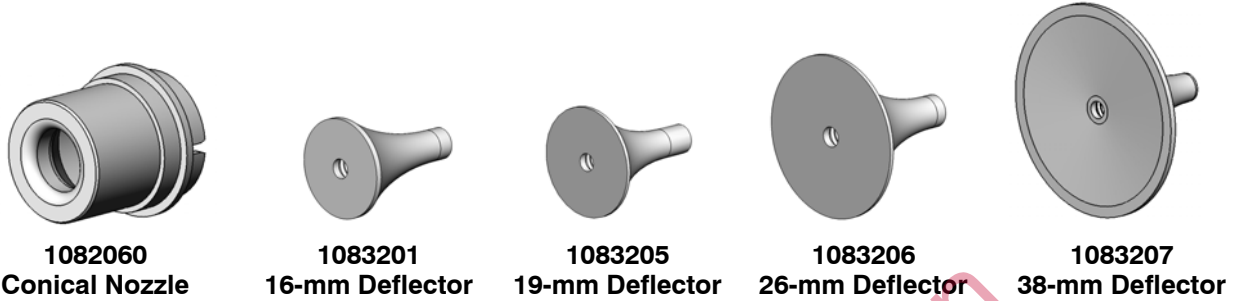

Figure 7-3 Conical Nozzle and Deflectors

Cross Cut Nozzles

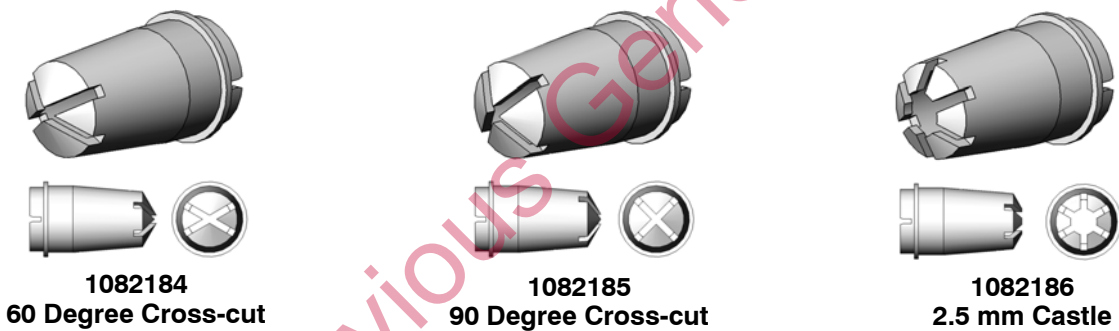
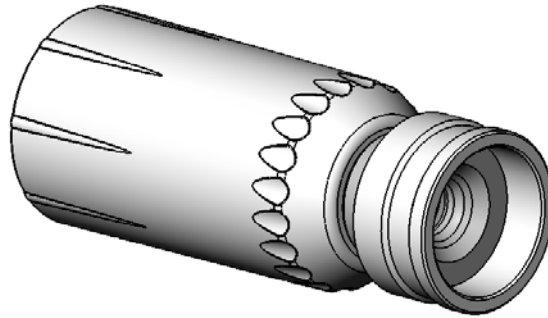

Figure 7-4 Cross-cut Nozzles

Pattern Adjuster Kit

The pattern adjuster kit includes an integral conical nozzle. 16, 19, and 26-mm deflectors can be used with the kit. The deflectors are not included with the kit; they must be ordered separately.



1098417
Kit, Pattern Adjuster, Manual Gun, Encore

Figure 7-5 Pattern Adjuster Kit

Lance Extensions

The nozzles listed on the preceding pages install directly on the lance extensions. Refer to the instruction sheet shipped with the lance extensions for installation instructions and repair parts.

Part	Description	Note
1093604	EXTENSION, lance, 150 mm, Encore	
1093605	EXTENSION, lance, 300 mm, Encore	
1600663	EXTENSION, lance, 600 mm, Encore	

Pattern Adjuster Kit for Lance Extensions

Use this pattern adjuster with the lance extensions listed above and 16, 19, and 26-mm conical nozzle deflectors listed on the preceding pages. Refer to the instruction sheet shipped with the pattern adjuster for installation instructions and repair parts.

Part	Description	Note
1100012	KIT, pattern adjuster, Encore lance extension.	

Controller Parts

Interface Exploded View

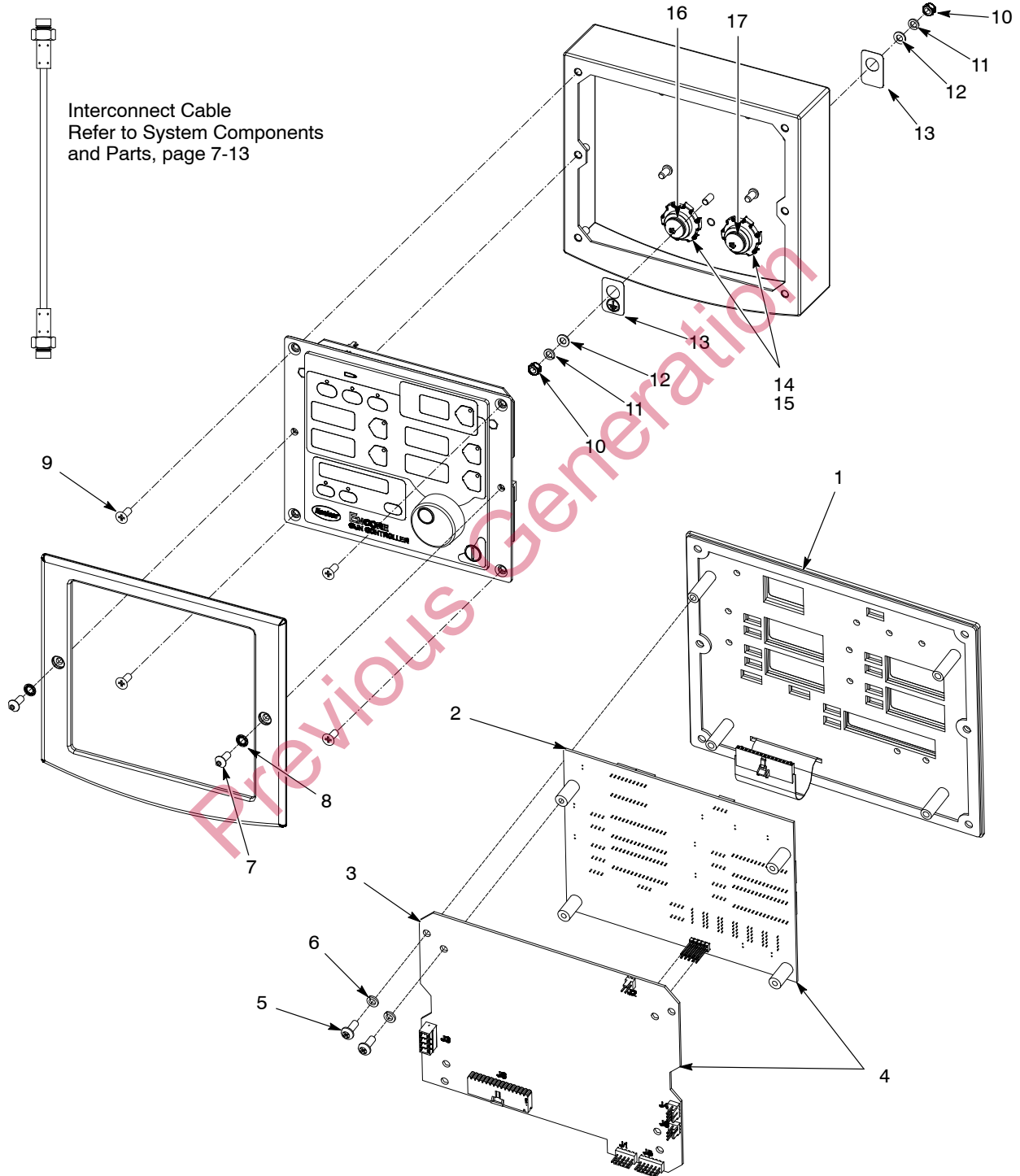

Figure 7-6 Interface Parts

Interface Parts List

Refer to Figure 7-6.

Item	Part	Description	Quantity	Note
-	1087276	CONTROL UNIT, interface, Encore, packaged	1	
1	1087271	• PANEL, keypad, Encore controller, packaged	1	
2	1085084	• KIT, PCA, main controller display, Encore, packaged	1	
3	1085085	• KIT, PCA, main control, Encore, packaged	1	
4	1085080	• KIT, PCA, control unit, interface, Encore	1	
5	982308	• SCREW, pan head, recessed, M4 x 10, zinc	8	
6	983403	• WASHER, lock, split, M4, steel, zinc	8	
7	982636	• SCREW, button, socket, M5 x 12, zinc	2	
8	983127	• WASHER, lock, internal, M5, zinc	2	
9	982286	• SCREW, flat, slotted, M5 x 10, zinc	4	
10	984702	• NUT, hex, m5, brass	2	
11	983401	• WASHER, lock, split, M5, steel, zinc	2	
12	983021	• WASHER, flat, 0.203 x 0.406 x 0.040, brass	2	
13	240674	• TAG, ground	2	
14	939122	• SEAL, conduit fitting, 1/2 in., blue	2	
15	984526	• NUT, lock, 1/2 in. conduit	2	
16	1082709	• RECEPTACLE, gun, Encore	1	A
17	1082759	• RECEPTACLE, net, controller interface, Encore	1	A

NOTE A: Receptacles include harnesses.

Power Unit Exploded View

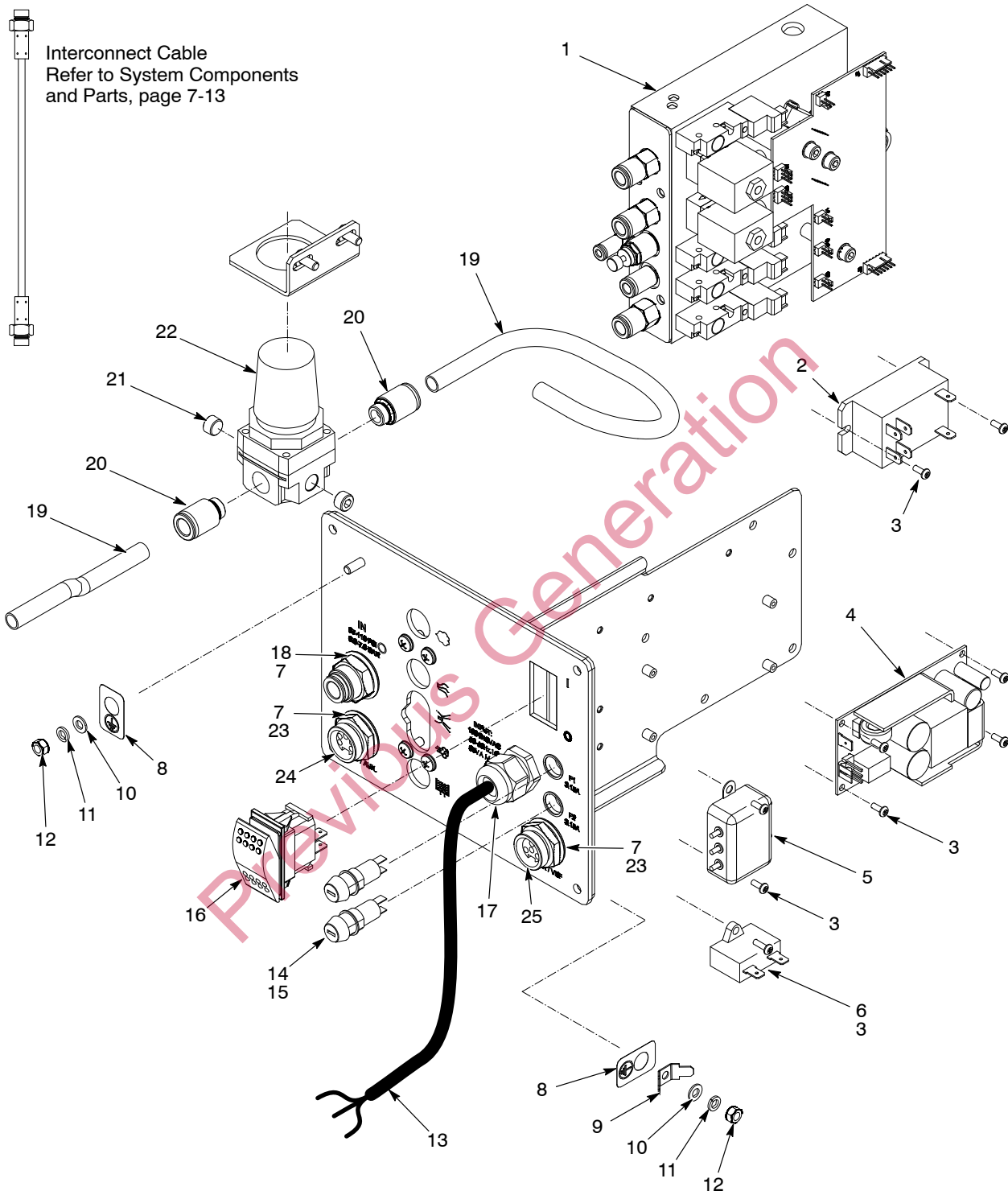

Figure 7-7 Power Unit Parts

Power Unit Parts List

Refer to Figure 7-7. If ordering a new power unit, order the correct voltage.

Item	Part	Description	Quantity	Note
-	1082815	POWER UNIT, controller, Encore, packaged, 230 V	1	
-	1600468	POWER UNIT, controller, Encore, packaged, 115 V	1	
1	1082714	• MODULE, iFlow, Encore, packaged	1	A
2	1068173	• RELAY, two pole, 30 amp, PCB/panel mount	1	
3	982824	• SCREW, pan head, recessed, M3 x 8 w/internal lockwasher	9	
4	1083053	• POWER SUPPLY, 24 VDC, 60 watt	1	
5	1082764	• FILTER, line, w/terminals	1	
6	1083021	• CAPACITOR, film, type 7124, 2.0 μ F	1	F
6	1600471	• CAPACITOR, film, type 7124, 4.0 μ F	1	G
7	939122	• SEAL, conduit fitting, 1/2 in. blue	3	
8	240674	• TAG, ground	3	
9	933469	• LUG, 90, double, 0.250, 0.438 in.	1	
10	983021	• WASHER, flat, 0.203 x 0.406 x 0.040 in., brass	3	
11	983401	• WASHER, lock, split, M5, steel, zinc	3	
12	984702	• NUT, hex, M5, brass	3	
13	1027067	• CORD, power, 15 ft (4.6 meters)	1	
14	288804	• FUSE HOLDER, panel mount, 5 x 20	2	
15	1009090	• FUSE, time delay, 215 series, 3.15A, 5 x20mm	2	
16	322404	• SWITCH, rocker, DPST, dust-tight	1	
17	972808	• CONNECTOR, strain relief, 1/2 in. NPT	1	
18	971109	• UNION, bulkhead, 10 mm x 10 mm tube	1	
19	900740	• TUBING, polyurethane, 10/6.5-7 mm	AR	B
20	972283	• CONNECTOR male, w/internal hex, 10 mm tube x 1/4 in. unithread	2	
21	-	• PLUG, pipe, socket, standard, 1/8 in. RPT, steel, zinc	2	
22	-	• REGULATOR, 1/8, 1/4 in. NPT, 7-125 psi	1	
23	984526	• NUT, lock, 1/2 in. conduit	2	
24	1082771	• RECEPTACLE, net, controller, Encore	1	E
25	1082770	• RECEPTACLE, output, VBF, controller, Encore	1	E
NS	1045098	• REDUCER, 10 mm stem x 8 mm tube	1	C
NS	1023695	• SEAL, bulkhead, 7/8-16 thread	1	D

NOTE A: Refer to iFlow Module Parts in this section for repair parts.

B: Order in increments of one foot.

C: Use to connect 8-mm fluidizing air to a powder feed hopper with a 10-mm tube fitting.

D: Use to cap GUN/VBF receptacle on power unit if not used.

E: Receptacles include harnesses.

F: Use this capacitor with the power unit (1082815) using a 230V VBF motor.

G: Only use this capacitor with the 115V power unit (1600468) using a vibrator motor with the model number MVE21M. If the vibrator motor model number is MVE20, then a 2.0 μ F capacitor (1083021) is acceptable.

AR: As Required

NS: Not Shown

iFlow Module Exploded View and Parts List

Figure 7-8 iFlow Module Parts

Item	Part	Description	Quantity	Note
-	1082714	MODULE, iFlow, Encore, packaged	1	
1	1099288	• VALVE, solenoid, 3-way, w/connector	4	
2	1027547	• VALVE, proportional, solenoid, sub-base	2	
3	1030873	• VALVE, check, M8 tube x 1/8 in. unithread	3	
4	972399	• CONNECTOR, male, w/internal hex, 6 mm tube x 1/8 in. unithread	1	
5	972125	• CONNECTOR, male, elbow, 10 mm tube x 1/4 in. unithread	1	

System Components and Parts

System Parts

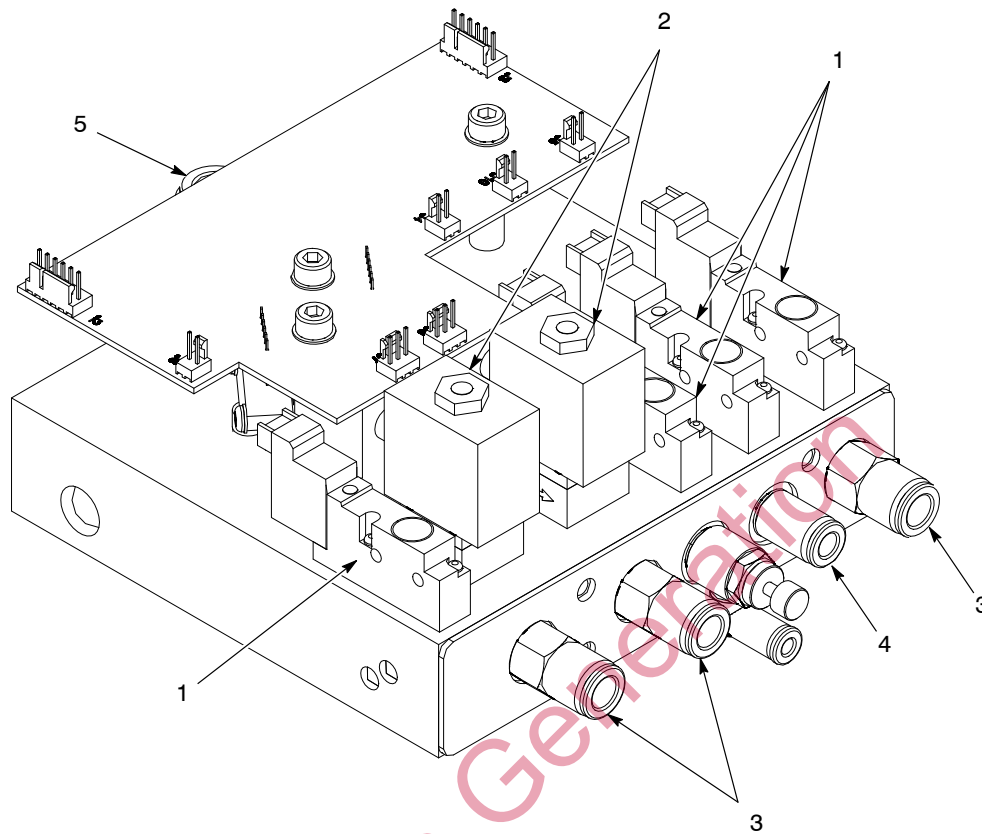
See Figure 7-9.

Item	Part	Description	Quantity	Note
1	1097809	TUBE, fluidizing, pickup, with conductive fitting, VBF, Encore	1	
1A	1096788	• CONNECTOR, 6mm tube x R 1/8, dia 0.7mm orifice	1	F
NS	1103081	ARM ASSEMBLY, pickup tube, Encore MPS, packaged	1	
2	1084760	ISOLATOR, vibration, 1.0 dia x 1.5 x 5/16 studs	3	
3	1080952	VIBRATOR, electric, 115V, 60 Hz, w/molded connector	1	A, I
3	1080950	VIBRATOR, electric, 230V, 50 Hz, w/molded connector	1	A
4	1101092	FILTER/REGULATOR, assembly, coalescing, with fittings (SMC, AWM20-02BE-CR)	1	G, H
NS	1101127	• FILTER ELEMENT, air, coalescing, 0.3 micron	1	G, H
NS	1018157	REGULATOR assembly, 0-25 psi, 0-1.7 bar, vertical	1	B
NS	972286	REDUCER, 8 mm stem x 6 mm tube	1	C
NS	148256	PLUG, 10 mm, tubing	1	D
NS	1096787	UNION, bulkhead, conductive, 6 mm tube	1	E
NS	1095922	PUMP, powder, Encore, generation II, packaged	1	J
NS	1067694	KIT, ground bus bar, ESD, 6 position, with hardware	1	
NS	1080718	CABLE, interface/controller, 10 ft.	1	

NOTE A: Order the correct vibrator motor for your system.

B: Fluidizing air regulator mounted next to interface module.

C: installed in power unit fluidizing air output fitting.

D: Plugs unused port in system air filter/regulator output fitting.

E: Conductive fitting, mounted inside tower. Do not replace this fitting with a non-conductive fitting.

F: Conductive fitting. Do not replace this fitting with a non-conductive fitting.

G: To replace the original Festo filter/regulator element, order 1085664.

H: This filter/regulator replaces the SMC 5-micron particulate filter/regulator, which is now an option. To order the 5-micron filter/regulator or filter element, refer to Options on page 7-15.

I: For motors with a model number of MVE21M, a 4.0 µF capacitor (1600471) must be used in the controller power unit. If the motor model number is MVE20, then a 2.0 µF capacitor (1083021) is acceptable.

J: Refer to pump manual 1095927 for repair kits.

NS: Not Shown

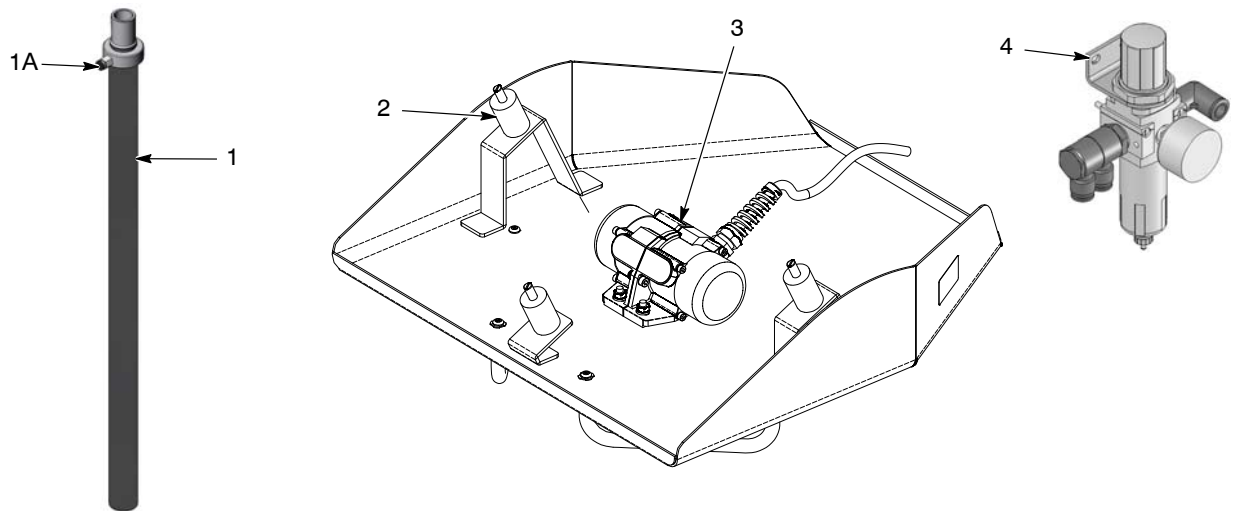

Figure 7-9 Miscellaneous System Parts

Powder Hose and Air Tubing

Powder hose and air tubing must be ordered in increments of one foot.

Part	Description	Note
768176	Powder hose, 11 mm antistatic	A, E
768178	Powder hose, 12.7 mm (1/2 in.) antistatic	A, E
900648	Powder hose, 11 mm blue	D
900650	Powder hose, 12.7 mm (1/2 in.) blue	D
900617	Air tubing, polyurethane, 4 mm, clear	B
900742	Air tubing, polyurethane, 6 mm, blue	B
1096789	Air tubing, antistatic, 6/4 mm, black (conductive air tubing)	C
900741	Air tubing, polyurethane, 6 mm, black	
900618	Air tubing, polyurethane, 8 mm, blue	B
900619	Air tubing, polyurethane, 8 mm, black	B
900740	Air tubing, polyurethane, 10 mm, blue	B
900517	Tubing, poly, spiral cut, 0.62 in. ID	
301841	Strap, Velcro, w/buckle, 25 x 3 cm	

NOTE A: Twenty feet of 11-mm antistatic hose is provided with the systems. If you need to use a longer length, you must switch to the 1/2 inch hose to prevent powder delivery issues.

B: Minimum order quantity is 50 ft.

C: This tubing is used on VBF systems to provide fluidizing air from the bulkhead union to the pickup tube. It is conductive and grounds the pickup tube to the cart body. Do not replace with non-conductive tubing.

D: Minimum order quantity is 25 ft.

E: Minimum order quantity is 100 ft.

Miscellaneous Options

Part	Description	Quantity	Note
1091429	KIT, input air, Encore manual systems	1	
972841	• CONNECTOR, male, 10 mm tube x 1/4 in. unithread	1	
971102	• CONNECTOR, male, 10 mm tube x 3/8 in. unithread	1	
973500	• COUPLING, pipe, hydraulic, 1/4 in., steel, zinc	1	
973520	• COUPLING, pipe, hydraulic, 3/8 in., steel, zinc	1	
900740	• TUBING, polyurethane, 10 mm, blue	20 ft	A
1096786	FILTER/REGULATOR, assembly, with fittings (particulate)	1	B
1097103	• FILTER ELEMENT, air, 5 micron	1	B

NOTE A: Order replacement tubing in increments of one foot.
 B: OEM assembly part number AW20-02BE-CR. Order the correct filter element for your filter/regulator. Elements are not interchangeable.

Cup Gun

See Figure 7-10. See the Encore Cup Gun instruction sheet for spare parts information.

Part	Description	Quantity	Note
1100777	KIT, cup gun, Encore	1	

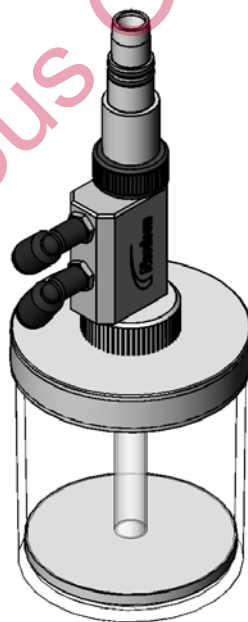

Figure 7-10 Cup Gun Kit

Pump Parts

Each Encore pump is shipped with a manual containing installation, repair, and parts information. Encore pump manuals can also be downloaded from the internet in PDF format from <http://emanuals.nordson.com>.

Coupling and Pump Adapter Kit

Wall and rail mount systems, and mobile systems with feed hoppers are shipped with an Encore pump adapter kit for use with the Encore Powder Pump. This adapter replaces the pump adapter with four external O-rings shipped with the hopper.

The coupling is shipped with wall and rail mount systems. It can be used instead of the adapter kit, however, it is recommended that the adapter kit be installed.

Item	Part	Description	Quantity	Note
-	1082204	COUPLING, pump, Encore	1	
1	1085679	KIT, pump adapter, Encore pump	1	
2	941145	<ul style="list-style-type: none"> O-RING, silicone, conductive, 0.625 x 0.812 in. 	2	

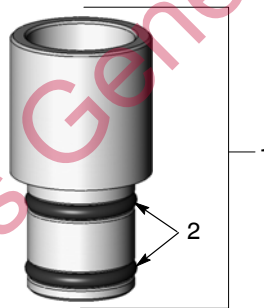

Figure 7-11 Encore Pump Adapter Kit

A

- Adapter
 - kit part number, 7-16
 - pump, 3-8
- Adhesive support pad, replacement, 6-2
- Air input kit, part number, 7-15
- Filter, element, 5 micron, 7-15
- Air supply
 - connection, 3-12
 - filter/regulator, 3-12
 - wall/rail mount, 3-13
- Air wash, operation, 4-5
- Air wash tubing, connection, gun, 3-11
- ATEX, conditions for safe use, 4-1

C

- Cable, gun, part number, 7-3
- Cables, interconnect, connecting, 3-3
- Classic mode
 - AFC, 4-15
 - standard, 4-14
- Cleaning, powder contact parts, 4-9
- Clearing, help codes, 4-12
- Components, of systems, 2-2
- Configuration
 - controller, 4-20
 - functions, 4-21
 - VBF, 4-21
 - number of presets, 4-22
 - saving, 4-22
- Conical nozzles, changing, 4-8
- Connections
 - air tubing and powder hose, gun, 3-11
 - controller, 3-5
 - electrical, 3-13
 - fluidizing, VBF, 3-6
 - gun cable, 3-10
 - interconnect cable, 3-3
 - powder hose, VBF, 3-6
 - power unit and interface, 3-3
 - pump
 - feed hopper, 3-9
 - power unit, 3-10
 - VBF, 3-6

- Controller
 - connections, 3-5
 - interface components, 4-11
- Coupling
 - part number, 7-16
 - pump, 3-8
- Cup Gun, 7-15

D

- Deflectors
 - changing, 4-8
 - part numbers, 7-6
- Diagrams, system, 3-4
- Dimensions, mobile systems, 2-3
- Display module, replacement, 6-2
- Displaying
 - help codes, 4-12
 - timers and software versions, 4-12
- Disposal, equipment, 1-3

E

- Electrical, connection, 3-13
- Electrode assembly, resistance test, 5-10
- Electrostatics
 - classic mode, 4-14
 - custom mode, 4-14
 - Select Charge , 4-13
- Extension, lance, 7-7
- Extensions, cable, 7-5

F

- Faults, troubleshooting, 5-2
- Feed hopper, filling, 4-2
- Filling, feed hopper, 4-2
- Flat spray nozzles
 - changing, 4-7
 - part numbers, 7-5

F *(cont...)*

- Fluidizing air
 - hopper, mobile system, 3-7
 - operation
 - feed hopper, 4-4
 - VBF, 4-4
 - pressures, 4-6
 - regulation, wall/rail mount system, 3-8
- Fuse, part number, 7-11

G

- Grounding
 - fluidizing tubing, VBF, 3-6
 - safety, 1-3
 - system, 3-14
- Gun cable
 - connections, 3-10
 - continuity test, 5-11
 - replacement, 6-7

H

- Hazardous location, ratings, 2-3
- Help code, chart, 5-2
- Help codes, 4-12
- Hopper, installation, mobile system, 3-7
- Hose, powder, part numbers, 7-14

I

- iFlow module
 - parts, 7-12
 - repair, 6-13
- Installation
 - pickup tube, 3-6
 - pump, VBF, 3-6
- Interconnect cable, continuity test, 5-11
- Interface
 - components, 4-11
 - parts, 7-8, 7-9
 - repair, 6-10
 - spray gun, 4-3
 - wiring diagram, 5-13
- Interface module, connections, 3-5
- Internet, manuals, download, 7-1
- IPX rating, 2-3

K

- Kits
 - body assembly, gun, 7-3
 - display module, 7-3
 - hose adapter, gun, 7-4
 - pattern adjuster, gun, 7-7
 - pattern adjuster, lance extensions, gun, 7-7
 - PCA, main controller display, 7-9
 - powder inlet tube, spray gun, 7-3
 - powder outlet tube, gun, 7-3
 - wear resistant, 7-5
 - trigger switch, gun, 7-3

L

- Labels, certification, 2-4
- Lance extensions, 7-7

M

- Maintenance
 - cleaning, powder contact parts, 4-9
 - procedures, 4-10
 - timer, 4-12
- Malfunctions, what to do, 1-3
- Manuals, systems and components, 7-1
- Mounting
 - rail, 3-2
 - wall, 3-1

N

- Nozzles
 - conical, 7-6
 - cross-cut, 7-6
 - flat spray, 7-5

O

- Operation
 - air wash, 4-5
 - daily, 4-5
 - initial startup, 4-5
 - shutdown, 4-9
 - spray gun, 4-3
 - standby button, 4-7
- Options
 - cup gun, 7-15
 - spray gun, 7-5

P**Parts**

- conical nozzles, 7-6
- cross-cut nozzles, 7-6
- flat spray nozzles, 7-5
- hose and tubing, 7-14
- iFlow module, 7-12
- interface, 7-8
- options, 7-15
- ordering, 7-1
- power unit, 7-10
- spray gun, 7-1
- system part numbers, 7-1

Pattern adjuster

- gun, 7-7
- lance extension, 7-7

Pattern adjuster kit, installing, 4-8**Pickup tube, installation, VBF, 3-6****Powder box, installation, 4-1****Powder flow settings**

- description, 4-15
- smart flow mode, 4-16

Powder hose, connection, gun, 3-11**Powder path, replacement, 6-5****Power supply**

- part number, 7-3
- replacement, 6-4
- resistance test, 5-10

Power unit

- connections, 3-5
- parts, 7-10, 7-11
- repair, 6-11
- wiring diagram, 5-12

Presets

- description, 4-13
- factory set, 4-7
- powder flow settings, 4-15
- selecting, 4-13
- setting number of, 4-22

Pressure, input air, 2-3**Proportional valve**

- cleaning, 6-15
- replacement, 6-17

Pump

- adapter, feed hopper, 3-8
- connections, hopper, 3-9
- coupling, feed hopper, 3-8
- installation
 - feed hoppers, 3-8
 - VBF, 3-6

parts, 7-16

Purge air tubing, connections, gun, 3-11

Purge

- powder hose, 4-4
- spray gun, 4-3

R

Rail, mounting, 3-2

Ratings, hazardous location, 2-3

Re-zero, procedure, 5-9

Reducer, fluidizing tubing, mobile system, 3-7

Regulator, adjustment, 6-12

Repair

- display module, 6-2
- iFlow module, 6-13
- interface module, 6-10
- powder path, 6-3
- power supply, 6-3
- power unit, 6-11
- proportional valve, 6-15
- regulator, 6-12
- vibrator motor, 6-17

Rotary knob, 4-11

S**Safety**

- disposal, 1-3
- fire, 1-2
- grounding, 1-3
- intended use, 1-1
- malfunctions, 1-3
- personal, 1-2
- qualified personnel, 1-1
- regulations and approvals, 1-1

Select charge mode, description, 4-13

Settings trigger

- changing powder flow with, 4-3
- changing presets with, 4-3

Settings, preset

- electrostatic, 4-13
- powder flow, 4-15

Shutdown, 4-9

S *(cont...)*

- Smart flow mode
 - classic flow mode, 4-20
 - description, 4-16
 - setting, 4-17
 - settings–english, 4-19
 - settings–metric units, 4-18
- Solenoid valve, replacement, 6-15
- Specifications, systems and components, 2-3
- Spray gun
 - connections, 3-10
 - cup gun, 7-15
 - options, 7-5
 - parts, 7-1
 - repair, 6-1
- Standby button, operation, 4-7
- System, diagram, 3-4
- System Components, parts, 7-13
- Systems, part numbers, 7-1

T

- Temperature, specifications, 2-3
- Timer, maintenance, 4-12
- Total hours, 4-12
- Trigger switch
 - connection, 6-2
 - replacement, 6-8
- Help codes
 - clearing, 5-1
 - viewing, 5-1
- Troubleshooting
 - electrode assembly, 5-10
 - general , 5-5
 - gun cable, 5-11
 - interconnect cable, 5-11
 - interface wiring diagram, 5-13
 - power supply, 5-10
 - power unit wiring diagram, 5-12
 - re–zero, 5-9
 - technical support, 5-1
 - with help codes, 5-1
- Tubing, part numbers, 7-14

V

- Vent hose
 - connection, mobile system, 3-7
 - installation, wall/rail mount system, 3-8
- Versions, of systems, 2-1
- Vibrator motor, replacement, 6-17
- Voltage, input specification, 2-3

W

- Wall, mounting, 3-1

DECLARATION of CONFORMITY

PRODUCT: Encore XT Manual Powder Spray System

Models: Encore XT, Fixed Mount or Mobile Dolly Unit

Description: This is a manual electrostatic powder spray system, including applicator, control cable and associated controllers.

Applicable Directives:

2006/42/EC – Machinery Directive

2004/108/EEC – EMC Directive

94/9/EC – ATEX Directive

Standards Used for Compliance:

EN/ISO12100-1 (2003)	EN60079-0 (2009)	EN61000-6-3 (2007)	FM7260 (1996)
EN1953 (1998)	EN50050 (2006)	EN61000-6-2 (2005)	
EN60204-1 (2006)	EN60079-31 (2009)	EN55011 (2009)	

Principles:

This product has been manufactured according to good engineering practice.
The product specified conforms to the directive and standards described above.

Type of Protection:

- Ambient Temperature: +15°C to +40°C
- Ex t IIIC T65°C Db IP 6X / Ex II 2D / 2mJ = (Applicator)
- EX t IIIC T60°C Dc IP 6X / Ex II 3 (2)D = (Controllers)

Certificates:

- SIRA08ATEX5010X (Eccleston, Chester, UK)

ATEX Surveillance:

- 1180 Baseefa (Buxton, Derbyshire, UK)



Mike Hansinger
Manager Engineering Development
Industrial Coating Systems

Date: 29 February 2012

Nordson Authorized Representative in the EU

Contact: Operations Manager
Industrial Coating Systems
Nordson Deutschland GmbH
Heinrich-Hertz-StraBe 42-44
D-40699 Erkrath



