

Prodigy Robot Gun Electrode Replacement



WARNING: Allow only qualified personnel to perform the following tasks. Follow the safety instructions in this document and all other related documentation.

Introduction

This instruction sheet covers the replacement of the electrode connected to the multiplier by the multiplier nut. The replacement kit includes the new electrode.

Electrode Replacement

NOTE: Purge gun before any disassembly.



WARNING: Turn off the electrostatic voltage and ground the spray gun electrode before performing the following tasks. Failure to observe this warning could result in a severe shock.

Electrode Removal

1. Disconnect the air tubing and control cable.
2. See Figure 1. Remove the nozzle.

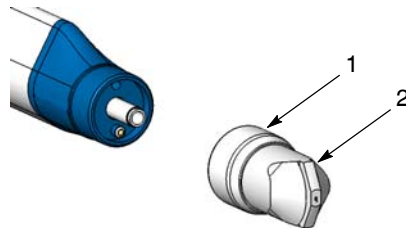

Figure 1 *Removing Nozzle*

1. Retaining nut

2. Nozzle

3. See Figure 2. Pull the barbed tube fitting (3) out of the gun and disconnect the flexible powder tubing from the tube fitting.

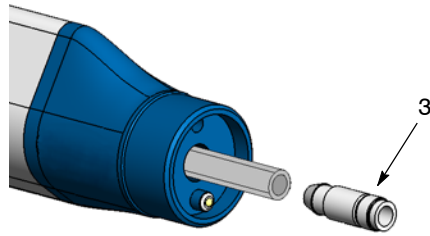

Figure 2 *Remove Barbed Tube Fitting*

3. Tube fitting

4. See Figure 3. Unscrew the lock knob (4) and pull the powder tubing out of the lock nut (5).



Figure 3 *Disconnecting Powder Tubing*

4. Lock knob
5. Lock nut

5. Remove the spray gun from the gun mount and move it to a clean work area.

6. See Figure 4. Remove the two screws (6) with a 2.5 mm hex wrench, then unscrew the lock nut (5).



Figure 4 *Removing Heat Sink Screws and Lock Nut*

5. Lock nut
6. Screws (2)

7. See Figure 5. Pull the heat sink (7) away from the housing (12) just enough to disconnect the air tubing (9) from the connector (8).

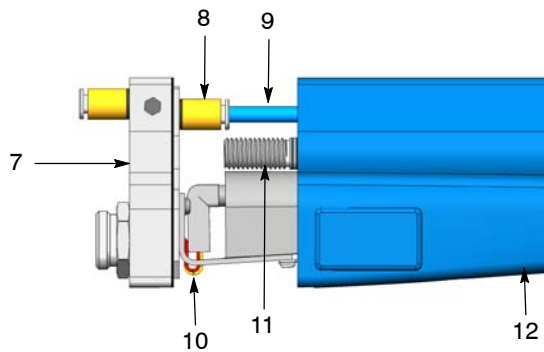

Figure 5 *Pulling the Heat Sink away from the Housing*

- | | |
|--------------------|-------------------|
| 7. Heat sink | 8. Connector |
| 9. Air tubing | 10. Harness wires |
| 11. Tubing channel | 12. Housing |

8. See Figure 6. Pull the heat sink (7), with multiplier (15) attached, out of the housing. Continue pulling until you can grasp the multiplier nut (14).
9. Unscrew the multiplier nut (14) and disconnect the electrode cable (13) from the multiplier (15).

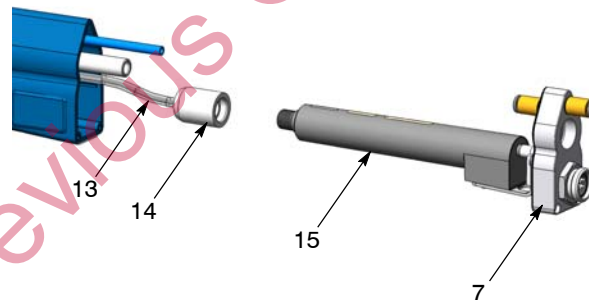

Figure 6 *Removing the Multiplier from the Housing and Disconnecting Electrode Cable*

- | | |
|--------------------|---------------------|
| 7. Heat sink | 13. Electrode cable |
| 14. Multiplier nut | 15. Multiplier |

10. Remove the electrode from the housing (12). Remove the multiplier nut by sliding it down the length the electrode.

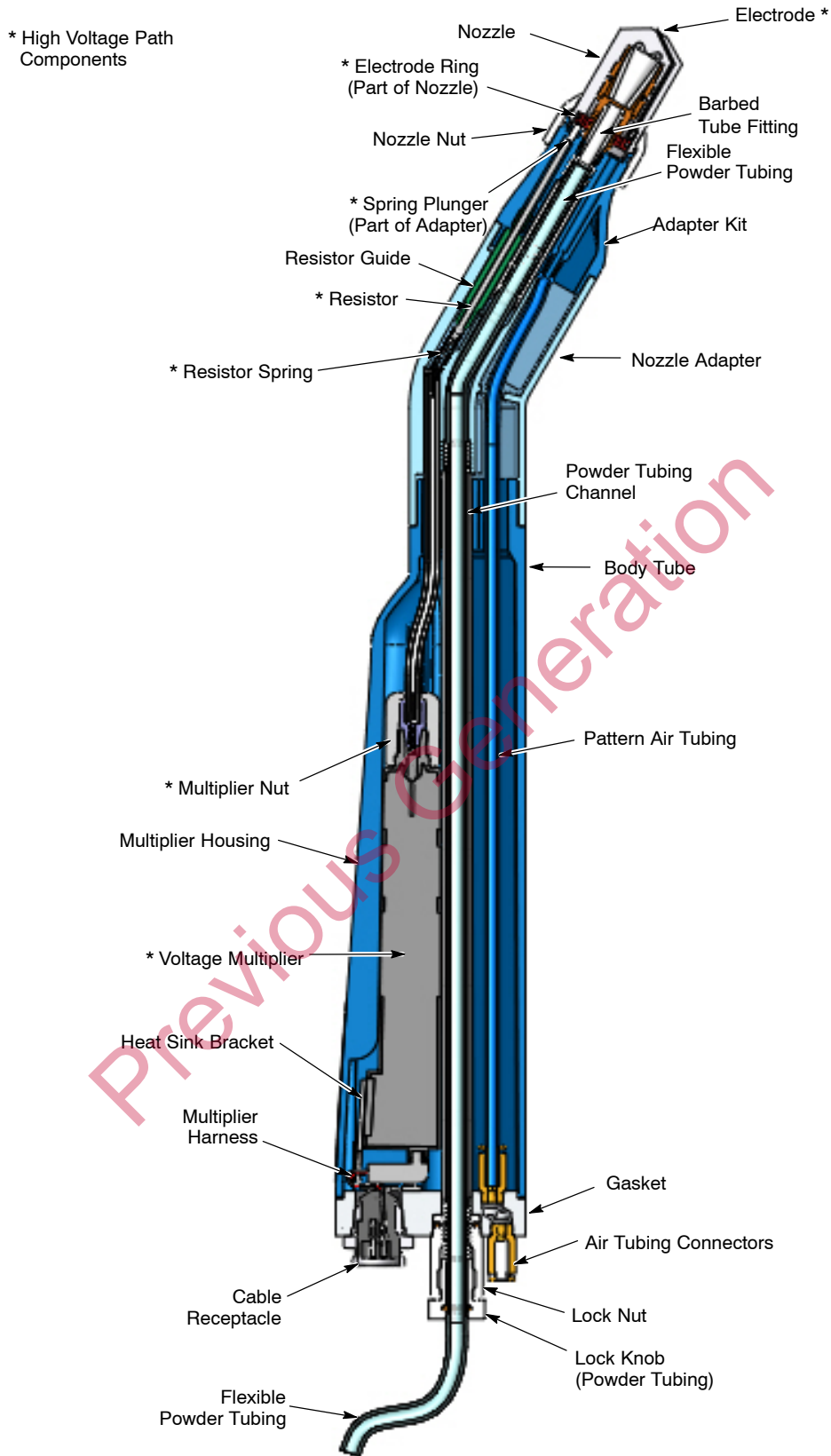

Figure 8 Section View – Prodigy Robot Gun (Shown with 30 Degree Nozzle Adapter)

Continuity and Resistance Tests



WARNING: Allow only qualified personnel to perform the following tasks. Follow the safety instructions in this document and all other related documentation.



WARNING: Turn off the electrostatic voltage and ground the spray gun electrode before performing the following tasks. Failure to observe this warning could result in a severe shock.

Resistance Tests

Use a 500 volt megohm meter to make these tests.

Multiplier/Resistor Test – All Versions

NOTE: The retaining nut (1) and nozzle (2) should be removed before beginning this test. The control cable should also be disconnected.

1. See Figure 9. Short together receptacle pins 2, 3, and 4 and connect them to the positive megohm meter probe.

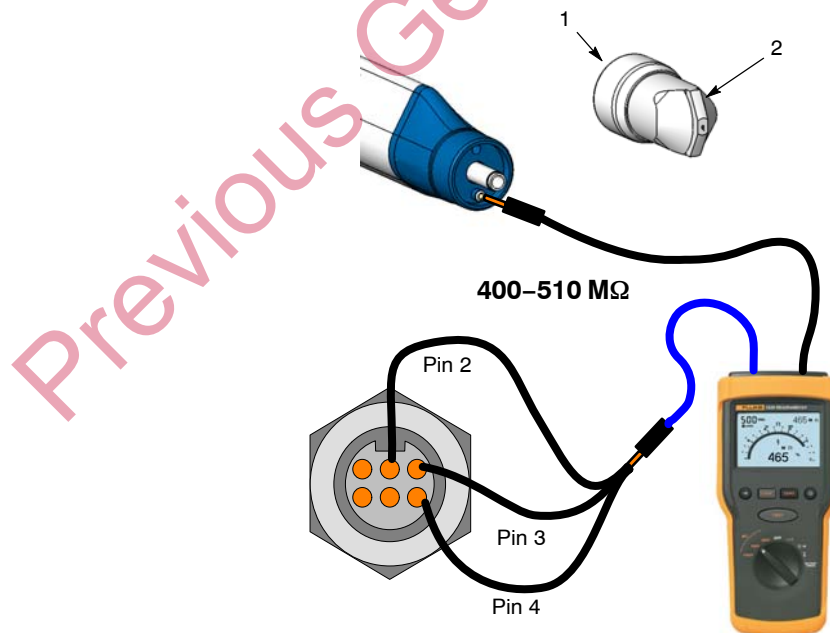

Figure 9 Multiplier/Resistor Test

1. Retaining nut

2. Nozzle



CAUTION: You must short multiplier receptacle pins 2, 3, and 4 together before performing this test to avoid damaging the multiplier.

2. Connect the negative megohm meter probe to the adapter spring plunger.

The megohm meter reading should be 400–510 megohms.

If the reading is out of this range, refer to the repair section in the Prodigy Robot Gun manual.

Parts List

See Figure 10.

Part	Description	Quantity
1105516	KIT, electrode, Prodigy Robot Gun	1



Figure 10 Electrode Assembly

Previous Generation

Issued 04/11

Original copyright date 2011. Prodigy, Nordson, and the Nordson logo are registered trademarks of Nordson Corporation.