

AFC Control Kit Installation

Kit P/N 170 833

1. Introduction

The Adjustable Feedback Current (AFC) Control kit is a field-installable option for Nordson Versa-Spray IPS control units. It provides a user-adjustable feedback current threshold for close-range coating of interior corners and deep recesses, also known as Faraday cage areas.

The AFC control produces the optimum combination of kV output and electric field strength for these hard-to-coat areas, improving coverage and finish quality. It can also be used to recoat coated and cured parts.

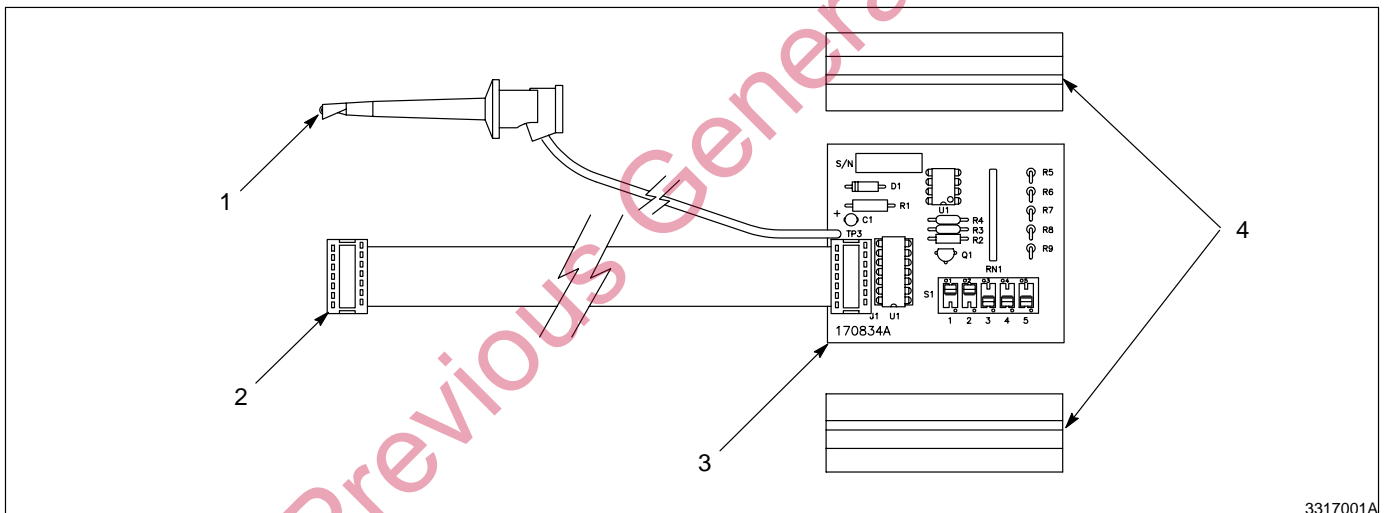

Figure 1 AFC control kit parts

- 1. Hook probe
- 2. Ribbon cable

3. AFC circuit board

4. Mounting clips

The AFC kit consists of a circuit board with a ribbon cable, hook probe, and mounting clips. None of the components of the kit can be ordered separately. The mounting clips are used to attach the circuit board to the top of the pneumatic output module inside the IPS control unit cabinet. The ribbon cable and hook probe are connected to the control module circuit board.

Dipswitch S1, on the AFC board, has five toggle switches that allow you to enable or disable the board function and to set the threshold value. When the board function is disabled, the control unit will function normally.

2. Installation



WARNING: Disconnect, lockout, and tag electrical power at a circuit breaker or disconnect switch in the service line ahead of the control unit before performing this procedure. Failure to observe this precaution may result in injury or death.

1. Loosen the captive screws at the four corners of the control unit front panel and slide the control module out of the cabinet. You must have access to the module circuit board and pneumatic output manifold.

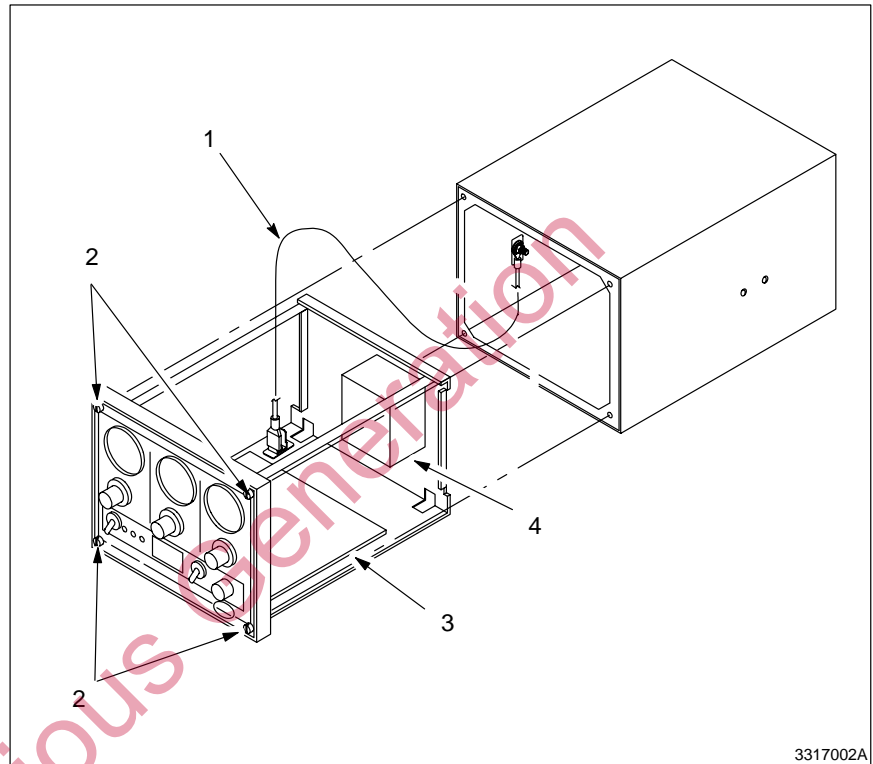

Figure 2 Accessing circuit board and pneumatic output module

- | | |
|-------------------|----------------------------|
| 1. Cabinet ground | 3. Circuit board |
| 2. Captive screws | 4. Pneumatic output module |

2. See Figure 3. Locate the U1 IC chip on the control module circuit board.
3. Remove the U1 chip from its socket with a chip puller or small flat-bladed screwdriver.

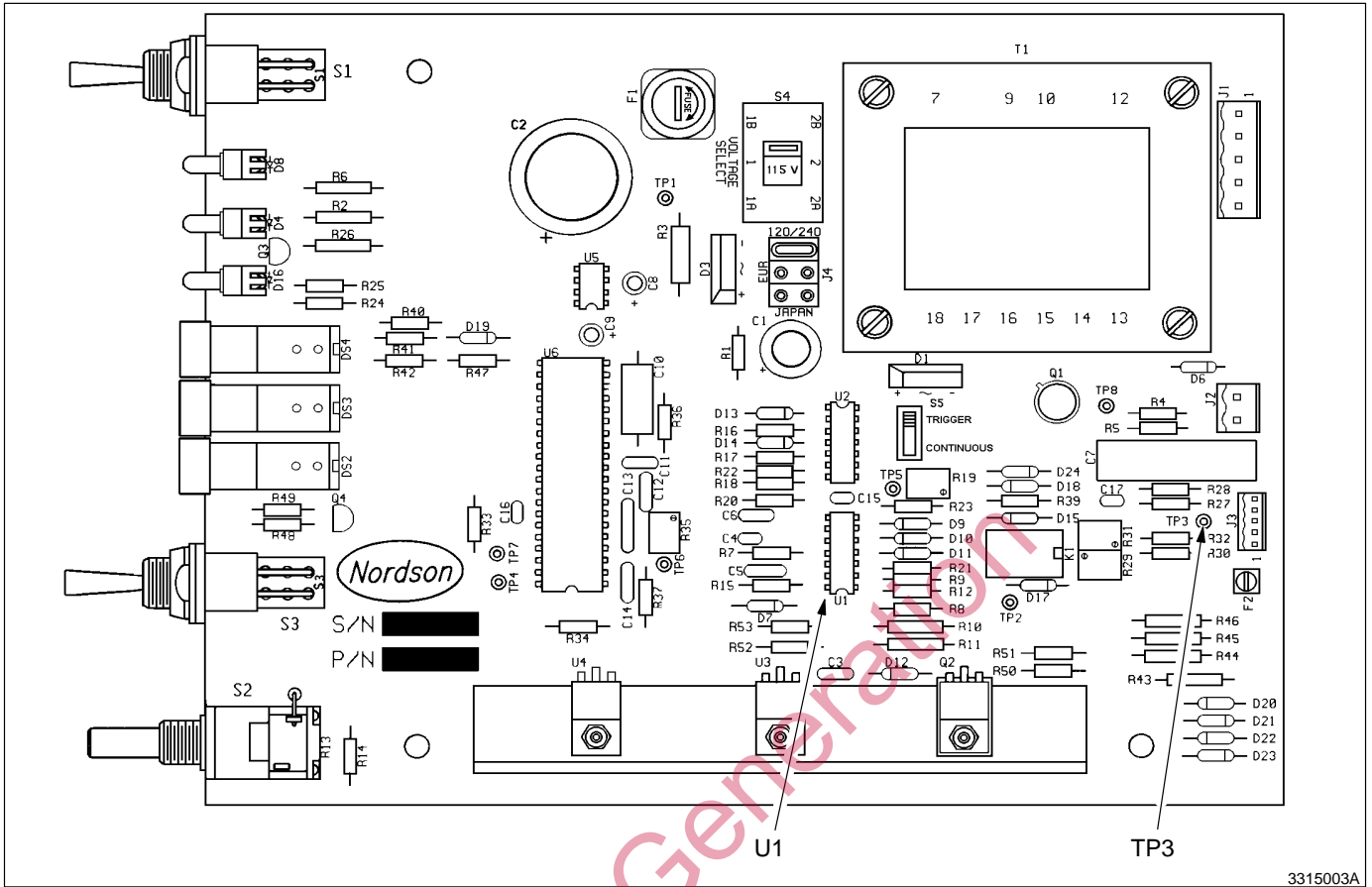

Figure 3 Control module circuit board – U1 and TP3 locations

4. Remove the AFC circuit board from its shipping container and antistatic bag.
5. See Figure 4. Install the mounting clips on the AFC circuit board.

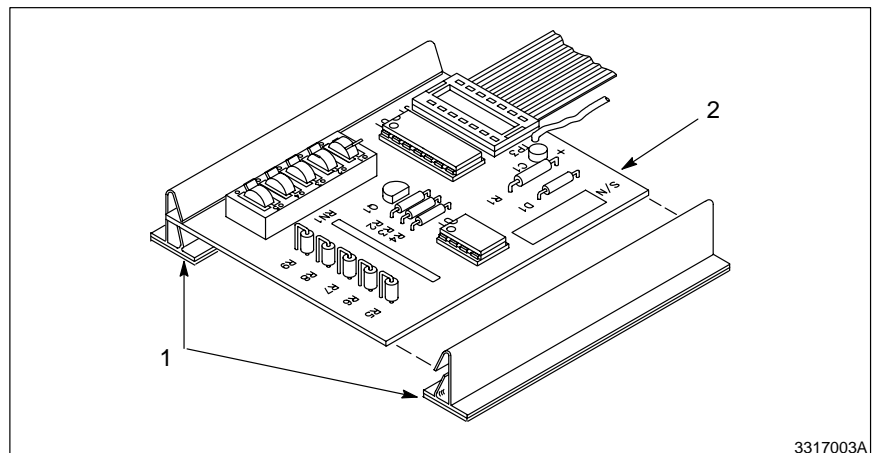

Figure 4 Installing mounting clips on AFC circuit board

1. Mounting clips

2. AFC circuit board

2. Installation (contd.)

6. Clean the top of the pneumatic output manifold. Dust and oil will prevent the adhesive tape on the mounting clips from sticking to the manifold.
7. Remove the adhesive tape backing from the mounting clips and mount the AFC circuit board on top of the manifold.
8. See Figure 3. Connect the hook probe to test point TP3 on the control module circuit board.
9. See Figure 5. Orient the cable connector so the brown trace is closest to the "U1" legend on the control module circuit board. Carefully plug the cable connector into the U1 socket.

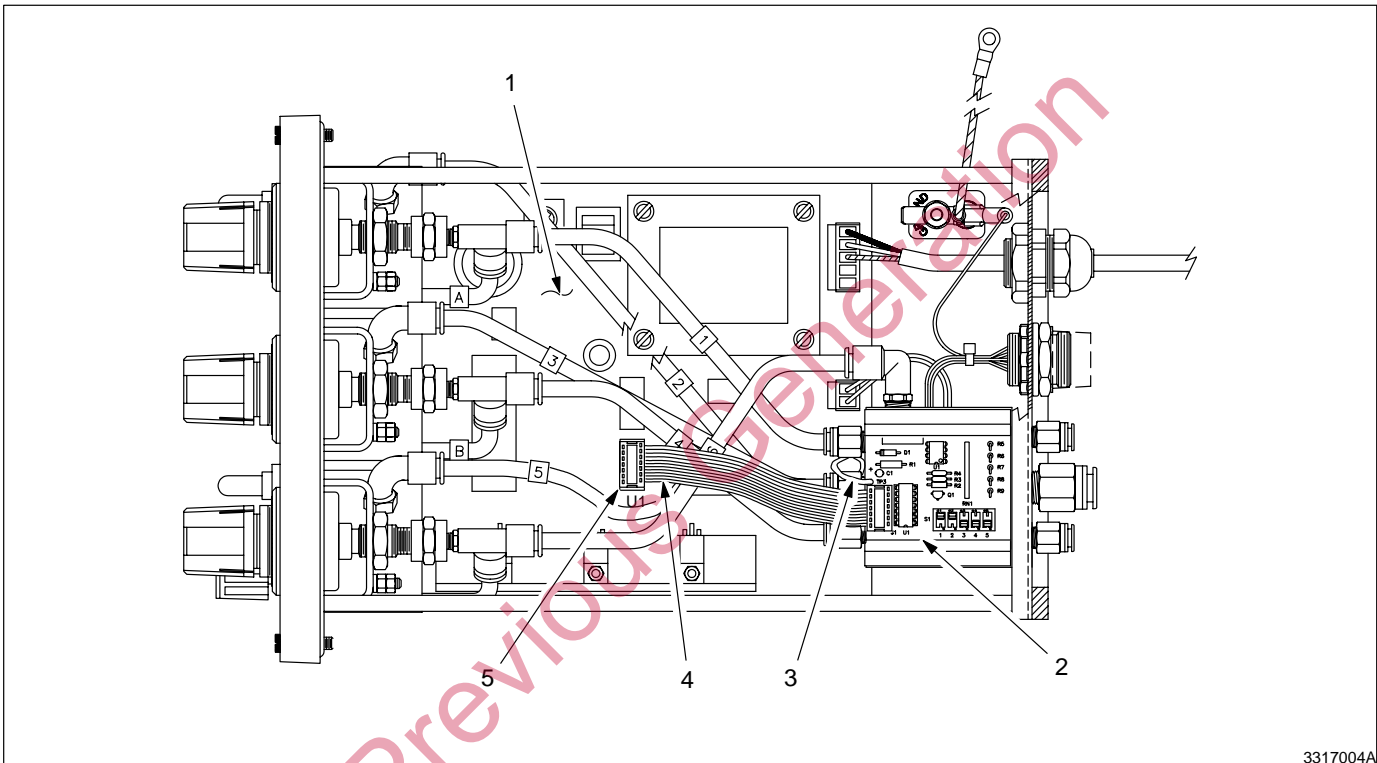

3317004A

Figure 5 AFC board installed

1. Control module circuit board
2. AFC circuit board

3. Hook probe wire
4. Ribbon cable brown trace

5. Ribbon cable connector

3. Setup

See Figure 6. Locate switch S1 on the AFC circuit board. Set toggle switches S1-2 through S1-5 to the desired threshold value. Use Table 1 to determine the switch settings.

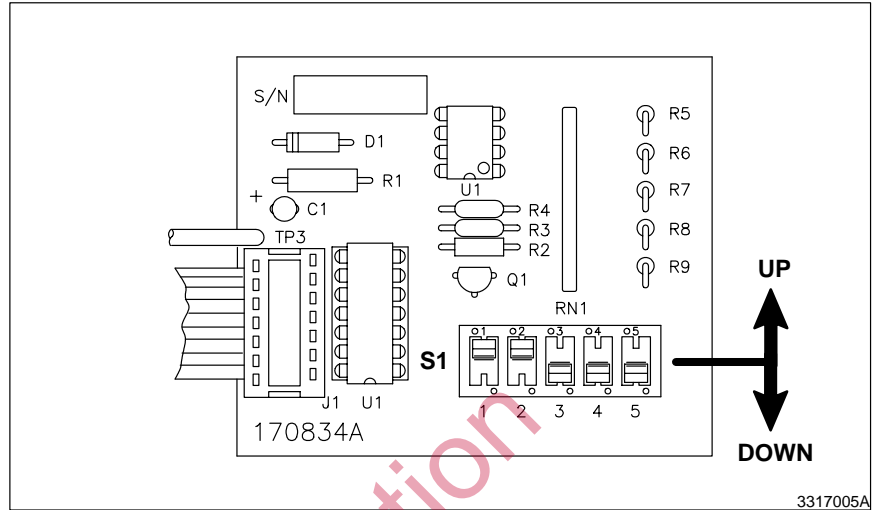

Figure 6 AFC circuit board dipswitch

NOTE: Switch S1-1 is used to enable or disable the board function. Up enables, down disables.

Table 1 Threshold Value Dipswitch Settings

Threshold (microamps)	Switches (U=Up, D=Down)				Threshold (microamps)	Switches (U=Up, D=Down)			
	S1-2	S1-3	S1-4	S1-5		S1-2	S1-3	S1-4	S1-5
0	D	D	D	D	40	U	D	D	D
5	D	D	D	U	45	U	D	D	U
10	D	D	U	D	50	U	D	U	D
15	D	D	U	U	55	U	D	U	U
20	D	U	D	D	60	U	U	D	D
25	D	U	D	U	65	U	U	D	U
30	D	U	U	D	70	U	U	U	D
35	D	U	U	U	75	U	U	U	U

Previous Generation

Nordson, the Nordson logo and Versa-Spray are registered trademarks of Nordson Corporation.