

# Tribomatic® Cup Gun Kit

---

## 1. Introduction

---

The Tribomatic Cup Gun Kit was designed to easily attach onto your Tribomatic gun without dismantling the gun. The cup gun kit is perfect for testing a new powder, color, or for coating a small object when a full hopper is unnecessary.

---

## 2. Installation

---

See Figure 1. Follow these steps to install the cup gun kit onto your Tribomatic gun.

1. Grasp the diffuser (9) on your Tribomatic II gun and with a slight twisting motion, pull to remove.
2. Insert the pump/diffuser assembly included with the cup gun kit into your Tribomatic II gun.
3. Insert the flow air line into the elbow air fitting (1) at the end of the cup gun diffuser.
4. Insert the diffuser air line into the straight air fitting (8) located under the diffuser body.
5. Remove the lid (5) and the cap from the funnel (9).
6. Push the funnel into the hole in the top of the pump/diffuser body (6) with a slight twisting motion until it is snug.

---

## 3. Operation

---

Use these steps to operate the Tribomatic Cup Gun Kit.

1. Fill the cup gun funnel with powder coating material.
2. Turn the control unit on, and adjust the diffusing air pressure to 1.7 bar (25 psi).
3. With the flow rate air pressure at zero, trigger the gun and slowly increase the pressure until the desired powder flow is achieved.

**NOTE:** Actual pressure settings will vary depending on the powder type and spraying conditions.

**4. Cleaning**



**CAUTION:** During cleaning with compressed air, steps should be taken to prevent powder from being blown back into the control gauges and regulators.

**NOTE:** Set the flow air and atomizing air pressures at 3.4 bar (50 psi) before triggering the gun to clean. This will prevent powder from migrating back into the controls.



**WARNING:** Be sure to be properly grounded when cleaning the Tribomatic II gun. Blowing air through the gun will generate a static charge.

Use a compressed-air gun to clean out the cup gun after use.

**5. Parts**

See Figure 1. Use this list to order parts for the Tribomatic Cup Gun Kit.

Item	Part	Description	Quantity	Note
—	183 469	Kit, cup gun, Tribo	1	
1	183 456	Fitting, swv, el, 6 mm TBG x 1/8 BPST	1	
2	183 462	Nozzle, venturi, cup gun	1	
3	940 126	O-ring, slcne, 0.375 x 0.50 x 0.063	2	
4	183 451	Funnel, molded, cup gun	1	
5	183 453	Lid, funnel, cup gun	1	
6	183 457	Housing, short, diffuser, cup gun	1	
7	940 224	O-ring, slcne, 1.00 x 1.125 x 0.063	2	
8	972 080	Connector, male, 1/4 tube x 1/8 NPTF	1	
NS	900 784	Cap/plug, tapered, 0.485 OD	1	
NS	183 464	Kit, funnel, w/lid and cap	AR	

AR: As Required

NS: Not Shown

**5. Parts (contd.)**

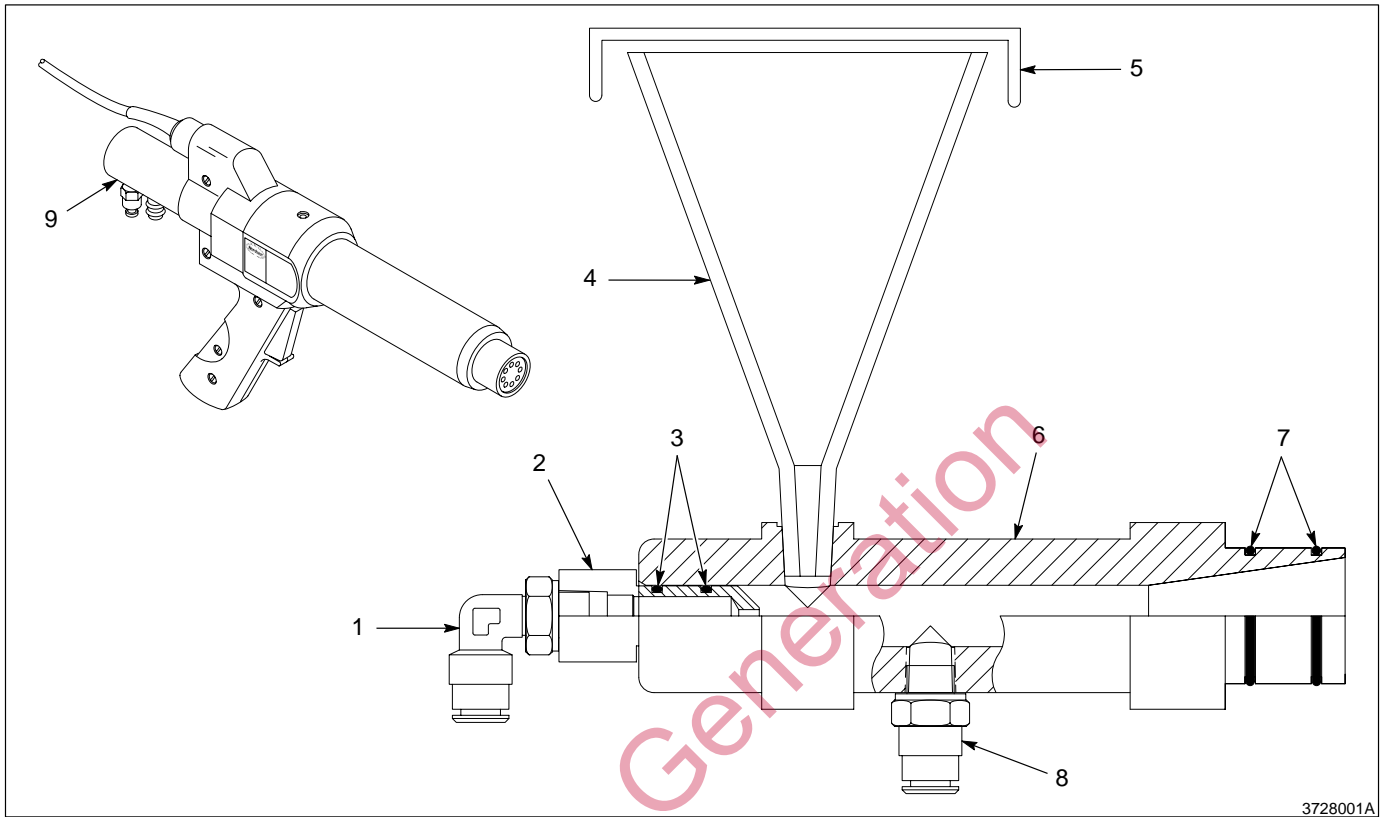

3728001A

Fig. 1 Tribomatic Cup Gun Kit

Tribomatic, Nordson and the Nordson logo are registered trademarks of Nordson Corporation.

Previous Generation