

# **Vantage<sup>®</sup>** **Manual Powder Spray Gun**

Customer Product Manual

Part 1070278-04

Issued 04/16

**For parts and technical support, call the  
Finishing Customer Support Center at (800) 433-9319.**

This document is subject to change without notice.  
Check <http://emanuals.nordson.com/finishing> for the latest version.

---



NORDSON CORPORATION • AMHERST, OHIO • USA

# Table of Contents

<b>Safety</b> .....	<b>1</b>	<b>Repair</b> .....	<b>12</b>
Qualified Personnel .....	1	Multiplier Replacement .....	12
Intended Use .....	1	Cable Replacement .....	12
Regulations and Approvals .....	1	Contact Tip Replacement .....	13
Personal Safety .....	1	Resistor Replacement .....	14
Fire Safety .....	2	<b>Parts</b> .....	<b>15</b>
Grounding .....	2	Using the Illustrated Parts List .....	15
Action in the Event of a Malfunction .....	2	Gun Parts .....	16
Disposal .....	2	Service Kits .....	18
<b>Description</b> .....	<b>3</b>	Cable Service Kit .....	18
Introduction .....	3	Multiplier Service Kits .....	19
Operation .....	3	Resistor Service Kit .....	19
Specifications .....	3	Handle Service Kit .....	20
<b>Installation</b> .....	<b>4</b>	Trigger Service Kit .....	20
<b>Operation</b> .....	<b>6</b>	Shorting Plug .....	21
Startup .....	6	Powder Feed Hose .....	21
Shutdown .....	6	<b>Options</b> .....	<b>21</b>
<b>Maintenance</b> .....	<b>6</b>	Option Descriptions .....	21
Daily Maintenance .....	6	Option Part Numbers .....	22
Weekly Maintenance .....	7	Optional Nozzles .....	23
<b>Troubleshooting</b> .....	<b>8</b>	Flat-Spray Nozzle Selection .....	23
Continuity and Resistance Checks .....	10	Flat-Spray Nozzle Parts .....	23
Multiplier/Resistor Assembly .....		Conical Nozzle and Deflector Selection .....	24
Resistance Check .....	10	Conical Nozzle and Deflector Parts .....	25
Resistor Resistance Check .....	10		
Gun Cable Continuity Checks .....	11		

---

## Contact Us

Nordson Corporation welcomes requests for information, comments, and inquiries about its products. General information about Nordson can be found on the Internet using the following address:  
<http://www.nordson.com>.

Address all correspondence to:

Nordson Corporation  
 Attn: Customer Service  
 555 Jackson Street  
 Amherst, OH 44001

## Notice

This is a Nordson Corporation publication which is protected by copyright. Original copyright date 2006. No part of this document may be photocopied, reproduced, or translated to another language without the prior written consent of Nordson Corporation. The information contained in this publication is subject to change without notice.

## Trademarks

Cross-Cut, Nordson, the Nordson logo, and Vantage are registered trademarks of Nordson Corporation.

Tivar is a registered trademark of Poly Hi Solidur, Inc.





# Vantage® Manual Powder Spray Gun

## Safety

Read and follow these safety instructions. Task- and equipment-specific warnings, cautions, and instructions are included in equipment documentation where appropriate.

Make sure all equipment documentation, including these instructions, is accessible to all persons operating or servicing equipment.

## Qualified Personnel

Equipment owners are responsible for making sure that Nordson equipment is installed, operated, and serviced by qualified personnel. Qualified personnel are those employees or contractors who are trained to safely perform their assigned tasks. They are familiar with all relevant safety rules and regulations and are physically capable of performing their assigned tasks.

## Intended Use

Use of Nordson equipment in ways other than those described in the documentation supplied with the equipment may result in injury to persons or damage to property.

Some examples of unintended use of equipment include

- using incompatible materials
- making unauthorized modifications
- removing or bypassing safety guards or interlocks
- using incompatible or damaged parts
- using unapproved auxiliary equipment
- operating equipment in excess of maximum ratings

## Regulations and Approvals

Make sure all equipment is rated and approved for the environment in which it is used. Any approvals obtained for Nordson equipment will be voided if instructions for installation, operation, and service are not followed.

All phases of equipment installation must comply with all federal, state, and local codes.

## Personal Safety

To prevent injury follow these instructions.

- Do not operate or service equipment unless you are qualified.
- Do not operate equipment unless safety guards, doors, or covers are intact and automatic interlocks are operating properly. Do not bypass or disarm any safety devices.
- Keep clear of moving equipment. Before adjusting or servicing any moving equipment, shut off the power supply and wait until the equipment comes to a complete stop. Lock out power and secure the equipment to prevent unexpected movement.
- Relieve (bleed off) hydraulic and pneumatic pressure before adjusting or servicing pressurized systems or components. Disconnect, lock out, and tag switches before servicing electrical equipment.
- Obtain and read Safety Data Sheets (SDS) for all materials used. Follow the manufacturer's instructions for safe handling and use of materials, and use recommended personal protection devices.
- To prevent injury, be aware of less-obvious dangers in the workplace that often cannot be completely eliminated, such as hot surfaces, sharp edges, energized electrical circuits, and moving parts that cannot be enclosed or otherwise guarded for practical reasons.

### **Fire Safety**

To avoid a fire or explosion, follow these instructions.

- Do not smoke, weld, grind, or use open flames where flammable materials are being used or stored.
- Provide adequate ventilation to prevent dangerous concentrations of volatile materials or vapors. Refer to local codes or your material SDS for guidance.
- Do not disconnect live electrical circuits while working with flammable materials. Shut off power at a disconnect switch first to prevent sparking.
- Know where emergency stop buttons, shutoff valves, and fire extinguishers are located. If a fire starts in a spray booth, immediately shut off the spray system and exhaust fans.
- Clean, maintain, test, and repair equipment according to the instructions in your equipment documentation.
- Use only replacement parts that are designed for use with original equipment. Contact your Nordson representative for parts information and advice.

### **Grounding**



**WARNING:** Operating faulty electrostatic equipment is hazardous and can cause electrocution, fire, or explosion. Make resistance checks part of your periodic maintenance program. If you receive even a slight electrical shock or notice static sparking or arcing, shut down all electrical or electrostatic equipment immediately. Do not restart the equipment until the problem has been identified and corrected.

Grounding inside and around the booth openings must comply with NFPA requirements for Class II, Division 1 or 2 Hazardous Locations. Refer to NFPA 33, NFPA 70 (NEC articles 500, 502, and 516), and NFPA 77, latest conditions.

- All electrically conductive objects in the spray areas shall be electrically connected to ground with a resistance of not more than 1 megohm as measured with an instrument that applies at least 500 volts to the circuit being evaluated.
- Equipment to be grounded includes, but is not limited to, the floor of the spray area, operator platforms, hoppers, photoeye supports, and blow-off nozzles. Personnel working in the spray area must be grounded.
- There is a possible ignition potential from the charged human body. Personnel standing on a painted surface, such as an operator platform, or wearing non-conductive shoes, are not grounded. Personnel must wear shoes with conductive soles or use a ground strap to maintain a connection to ground when working with or around electrostatic equipment.
- Operators must maintain skin-to-handle contact between their hand and the gun handle to prevent shocks while operating manual electrostatic spray guns. If gloves must be worn, cut away the palm or fingers, wear electrically conductive gloves, or wear a grounding strap connected to the gun handle or other true earth ground.
- Shut off electrostatic power supplies and ground gun electrodes before making adjustments or cleaning powder spray guns.
- Connect all disconnected equipment, ground cables, and wires after servicing equipment.

### **Action in the Event of a Malfunction**

If a system or any equipment in a system malfunctions, shut off the system immediately and perform the following steps:

- Disconnect and lock out electrical power. Close pneumatic shutoff valves and relieve pressures.
- Identify the reason for the malfunction and correct it before restarting the equipment.

### **Disposal**

Dispose of equipment and materials used in operation and servicing according to local codes.

## Description

### Introduction

The Vantage Manual Powder Spray Gun electrostatically charges and sprays organic powder coatings. The integral power supply (multiplier) is user-replaceable. The spray gun is used with the Vantage Manual Spray Gun Control Unit and a standard or low-flow powder pump. The spray gun comes with a standard conical nozzle (4) and 19-mm deflector (5).

### Operation

The manual gun control unit supplies low-voltage dc power to the voltage multiplier housed in the spray gun's extension and body. The multiplier generates the high electrostatic voltage needed for powder coating. The voltage generates a high-strength electrostatic field between the spray gun and the grounded part in front of the spray gun. The electrostatic field produces a corona discharge around the electrode. A resistor in the spray gun between the multiplier and the electrode limits the current output to safe levels.

Compressed air pumps the powder from the feed hopper, conveys it through the feed hose to the spray gun, and propels it toward the workpieces. As the powder particles are sprayed through the corona, they pick up an electrostatic charge and are attracted to the workpieces.

The spray pattern is controlled by the shape of the nozzle used, the speed of the powder-conveying air as it exits the nozzle, and the electrostatic field generated between the electrode and the grounded workpiece. There are no controls on the spray gun except the trigger. The voltage controls and the powder pump flow rate and atomizing air pressure regulators are housed in the control unit. The pump air starts flowing when the trigger is pulled.

### Specifications

Maximum rated output voltage at the electrode:  
80,000 volts  $\pm 10\%$

Maximum rated output current at the electrode:  
0.180 mA  $\pm 10\%$

This equipment is rated for use in an explosive environment (Class II, Division I, Group F and G or Zone 21).

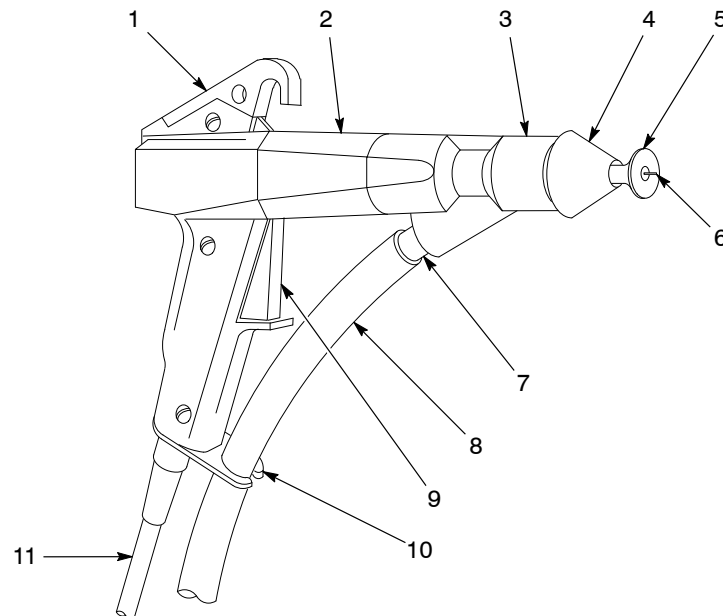

Figure 1 Vantage Manual Powder Spray Gun

- |                      |                      |                       |
|----------------------|----------------------|-----------------------|
| 1. Hanger            | 5. Deflector         | 9. Trigger            |
| 2. Extension         | 6. Electrode         | 10. Feed hose bracket |
| 3. Powder inlet body | 7. Feed hose adapter | 11. Cable             |
| 4. Nozzle            | 8. Feed hose         |                       |

## Installation



**WARNING:** Allow only qualified personnel to perform the following tasks. Follow the safety instructions in this document and all other related documentation.





**WARNING:** All electrically conductive equipment in the spray area must be grounded. Ungrounded or poorly grounded equipment can store an electrostatic charge, which can give personnel a severe shock or arc and cause a fire or explosion.

**NOTE:** Keep the powder feed hose as short as possible, no more than 12 m (39 ft) long if using 1/2-in. ID hose, or 4 m (13 ft) long if using 3/8-in. ID hose. Longer lengths may cause uneven powder flow.

Refer to Table 1 and see Figure 2 for a description of typical gun and control unit connections.

**NOTE:** Refer to the control unit, pump, and hopper manuals for more detailed installation instructions.

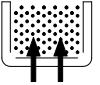
Table 1 Connections

Item	Description	Size	Control Unit Back Panel Connection	Other Equipment Connection
1	Ground Wire with Clamp	—		True Earth Ground
2	Fluidizing Air Tubing (Blue)	10-mm OD		Hopper Fluidizing Air Fitting
3	Atomizing Air Tubing (Blue)	8-mm OD		Powder Pump Connector <b>A</b>
4	Flow Rate Air Tubing (Black)	8-mm OD		Powder Pump Connector <b>F</b>
5	Feed Hose	12.7-mm (1/2-in.) ID	(not connected to control unit)	Powder Pump Outlet; Spray Gun Inlet
6	Spray Gun Cable	—	<b>GUN OUTPUT</b> (See Note)	Spray Gun Handle (prewired)
7	POWER INPUT Cable	—	<b>POWER INPUT</b> (prewired)	Main Power Supply
8	Air Supply Tubing (Blue)	10-mm OD	<b>IN</b> <b>0–100 PSI</b> <b>0–7 BAR</b>	Main Air Supply

**NOTE:** Tighten the gun cable retaining nut to 6 N•m (4.4 ft-lb). An optional 4-meter extension cable is available. Do not add more than two extension cables to the gun cable.



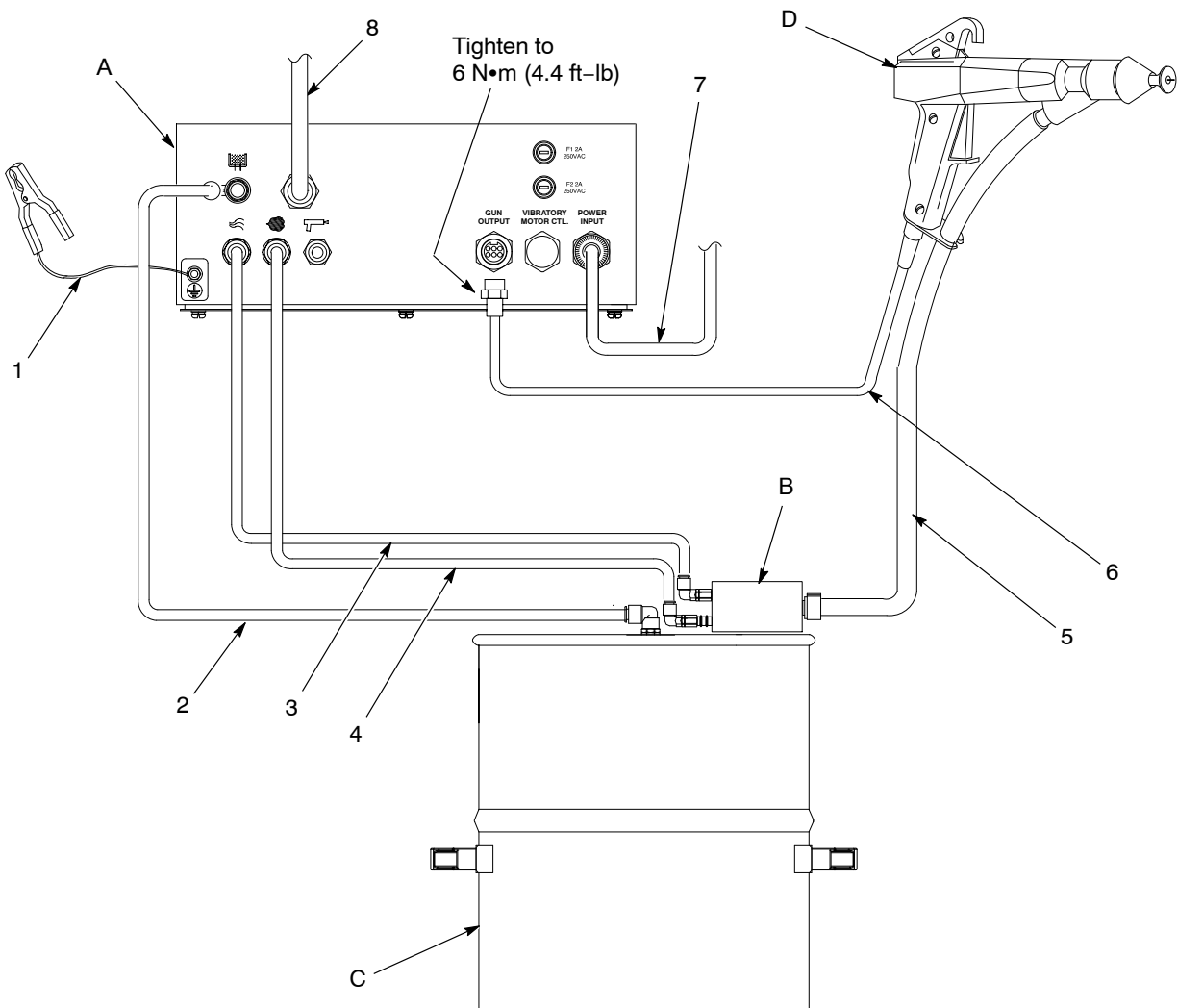

Figure 2 Connections

- |                 |  |                                |
|-----------------|--|--------------------------------|
| A. Control unit | 1. Ground wire with clamp              | 5. Feed hose                   |
| B. Powder pump  | 2. Blue, 10-mm air tubing (fluidizing) | 6. Gun cable                   |
| C. Hopper       | 3. Blue, 8-mm air tubing (atomizing)   | 7. POWER INPUT cable           |
| D. Spray gun    | 4. Black, 8-mm air tubing (flow rate)  | 8. Blue, 10-mm air tubing (IN) |

Note: Typical powder pump and hopper shown.

## Operation



**WARNING:** Allow only qualified personnel to perform the following tasks. Follow the safety instructions in this document and all other related documentation.



**WARNING:** This equipment can be dangerous unless it is used in accordance with the rules laid down in this manual.

## Startup



**WARNING:** Do not operate the spray gun if the resistor and multiplier resistances are not within the ranges specified in this manual. Failure to observe this warning may result in personal injury, fire, and property damage.



**WARNING:** The operator must maintain skin contact with the the gun handle. If wearing gloves, cut away the palm. Failure to observe this warning could result in a shock.

Before turning on the control unit, make sure that the

- booth exhaust fan is on,
- powder recovery system is operating, and
- powder supply in the feed hopper is adequately fluidized.

Refer to the appropriate equipment manuals for startup procedures.

1. Make sure the cable, feed hose, and air tubing are correctly connected to the spray gun, powder pump, and IPS control unit.
2. Turn the control unit power switch to the on position.
3. Point the spray gun into the booth, pull the trigger, and adjust the control unit air pressures and electrostatic setpoints as described in the control unit manual.

## Shutdown



**WARNING:** Turn off the electrostatic voltage and ground the gun electrode before making adjustments to the spray gun or nozzle.

1. Turn the control unit power switch to the off position. Ground the gun electrode to discharge any residual voltage.
2. Perform the *Daily Maintenance* procedure.

For information on the operation of other components of your powder spray system, refer to their manuals.

## Maintenance



**WARNING:** Turn off the electrostatic voltage and ground the gun electrode before performing the following tasks. Failure to observe this warning could result in a severe shock.

### Daily Maintenance

1. Disconnect the powder feed hose from the pump. Point the spray gun into the booth and blow the powder out of the hose and spray gun with low-pressure compressed air. Never blow air through the powder feed hose from the spray gun into the pump.
2. See Figure 3. Remove the nozzle parts (items 4–6) from the spray gun.
3. Loosen the set screw (7) and pull the powder inlet body (3) straight off the gun.
4. Clean the parts with a low-pressure air gun. Wipe the parts with a clean, dry cloth.
5. Blow powder off the resistor probe (2) and extension (1). Wipe them with a clean, dry cloth. Carefully remove fused powder from the parts with a wooden or plastic dowel or similar tool. Do not use tools that will scratch the plastic. Powder will build up and impact-fuse on any scratches.

**NOTE:** If necessary, use a cloth dampened with isopropyl or ethyl alcohol to clean the powder path parts. Remove the O-rings first. Do not immerse the spray gun in alcohol. Do not use any other solvents.

6. Inspect the powder path parts for wear. Replace worn parts.
7. Assemble the spray gun. Rotate items (4), (5), (6), and (8) at least 30° from their previous position to prevent uneven wear and lopsided patterns.

### **Weekly Maintenance**

Check the resistance of the multiplier/resistor probe assembly with a megohmmeter, as described in *Troubleshooting*. Replace the multiplier, resistor, or both, if the resistance readings do not fall within the specified ranges.

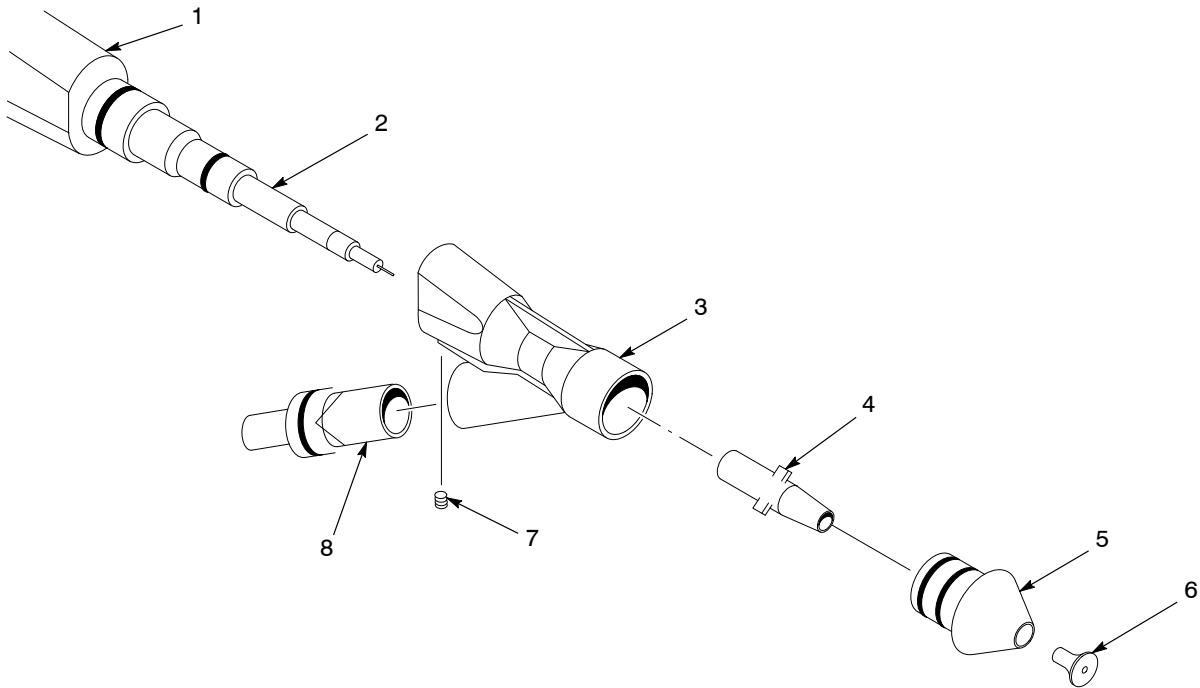

Figure 3 Daily Maintenance

- |                      |                   |                 |
|----------------------|-------------------|-----------------|
| 1. Extension         | 4. Wear sleeve    | 7. Set screw    |
| 2. Resistor probe    | 5. Conical nozzle | 8. Hose adapter |
| 3. Powder inlet body | 6. Deflector      |                 |

## Troubleshooting



**WARNING:** Allow only qualified personnel to perform the following tasks. Follow the safety instructions in this document and all other related documentation.

These procedures cover only the most common problems that you may encounter. If you cannot solve the problem with the information given here, call the Nordson Industrial Coating Systems Customer Support Center at (800) 433-9319 or contact your local Nordson representative for help.

If you are having problems with the electrostatic components of the spray gun, check their continuity and resistance with the procedures at the end of this section.

- multiplier/resistor assembly continuity and resistance
- resistor continuity and resistance
- gun cable continuity

### Troubleshooting Chart

Problem	Possible Cause	Corrective Action
1. <b>Uneven pattern; unsteady or inadequate powder flow</b>	Blockage in spray gun, feed hose, or pump	Disconnect the feed hose from the pump. Blow out the hose with compressed air. Disassemble the spray gun and pump and clean them. Replace the hose if it is clogged with fused powder.
	Deflector or nozzle worn, affecting pattern	Remove the deflector and nozzle. Clean and inspect them. Replace worn parts. If excessive wear or impact-fusion is a problem, reduce the flow rate and atomizing air pressures.
	Damp powder	Check the powder supply, air filters, and dryer. Replace the powder supply if it is contaminated.
	Low atomizing or flow rate air pressure Improper fluidization of powder in hopper	Increase the atomizing and/or flow rate air pressures. Increase the fluidizing air pressure. Remove the powder from hopper and clean or replace the fluidizing plate, if contaminated.
2. <b>Voids in powder pattern</b>	Worn nozzle or deflector	Remove the deflector and nozzle. Inspect and replace them if worn.
	Plugged powder path	Remove the nozzle parts and powder path from the spray gun and clean them.
<i>Continued...</i>		

Problem	Possible Cause	Corrective Action
<b>3. Loss of wrap; poor transfer efficiency</b>	<p>Low electrostatic voltage</p> <p>Resistor or control unit failure</p> <p>Poorly grounded parts</p>	<p>Increase the electrostatic voltage.</p> <p>Check the multiplier/resistor probe assembly with a megohmmeter for 195–270 megohms at 500 volts. If the reading is out-of-range, check the resistor probe separately.</p> <p>Check the conveyor chain, rollers, and part hangers for powder buildup. The resistance between the parts and ground must be 1 megohm or less. For best results, 500 ohms or less is recommended.</p>
<b>4. No kV output from spray gun</b>	<p>Malfunctioning trigger switch</p> <p>Damaged gun cable</p> <p>Malfunctioning voltage multiplier</p> <p>Failed gun resistor</p> <p>Malfunctioning control unit</p>	<p>Check for continuity between pins 1 and 2 (control unit end of cable) with the switch actuated. If no continuity is found, replace the cable.</p> <p>Check the continuity of the cable wires, from pin to pin. Replace the cable if any opens or shorts found.</p> <p>Use the optional shorting plug and a megohmmeter to check the continuity and resistance of the multiplier/resistor assembly for 195–270 megohms at 500 volts. No burn-throughs or arc tracks should be visible on any parts.</p> <p>Check the resistor with a megohmmeter for 153–187 megohms at 500 volts.</p> <p>Check for 21 Vdc between pins 2 and 3 (spray gun end of cable) with the trigger depressed.</p>

## Continuity and Resistance Checks



**WARNING:** Turn off the electrostatic voltage and ground the gun electrode before performing the following tasks. Failure to observe this warning could result in a severe shock.

**NOTE:** All three pins in the multiplier connector must be shorted together to check the continuity and resistance of the multiplier or multiplier/resistor assembly, or the multiplier could be damaged. The optional shorting plug makes these tasks easy. Refer to the *Options* section for the part number.

### Multiplier/Resistor Assembly Resistance Check

1. See Figure 4. Connect the shorting plug (2) to the multiplier connector (1).
2. Connect the megohmmeter (3) probes to the shorting plug ring-tong terminal and electrode (4). If you get an infinite reading, switch the probes.
3. The megohmmeter should read between 195 and 270 megohms at 500 volts. If the reading is out of this range, check the resistor separately (refer to *Resistor Continuity and Resistance Check*). If the resistor reading is within the range specified, replace the multiplier.

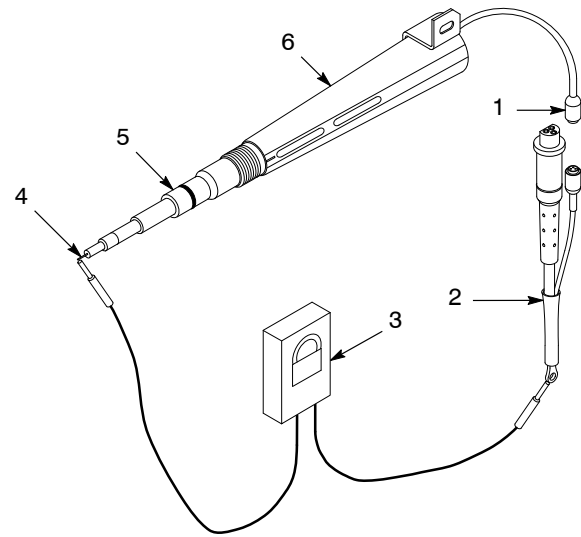

Figure 4 Multiplier/Resistor Assembly Resistance Check

- |                         |                   |
|-------------------------|-------------------|
| 1. Multiplier connector | 4. Electrode      |
| 2. Shorting plug        | 5. Resistor probe |
| 3. Megohmmeter          | 6. Multiplier     |

### Resistor Resistance Check

1. Perform the *Multiplier/Resistor Assembly Continuity and Resistance Check* procedure.
2. See Figure 5. Unscrew the resistor probe (2) from the multiplier (4).
3. Check the resistor with a megohmmeter. The megohmmeter should read between 153 and 187 megohms at 500 volts. If the reading is out of this range, replace the resistor probe.

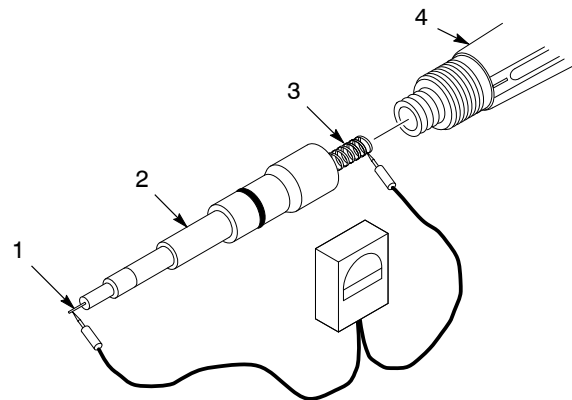

Figure 5 Multiplier/Resistor Assembly Resistance Check

- |                   |                   |
|-------------------|-------------------|
| 1. Electrode      | 3. Spring contact |
| 2. Resistor probe | 4. Multiplier     |

## Gun Cable Continuity Checks

Cable pins and wire colors are shown in Figure 6. To make sure the cable is not damaged, check for continuity with a standard ohmmeter.

Table 2 Control Unit End Pin Functions

Control Unit End Pins	Function
1	Trigger
2	Negative (Common)
3	Positive (+21 Vdc)
4	μA Feedback
5	Open
6	Ground

Table 3 Gun Cable Continuity Checks

Control Unit End Pins	Gun End Pins and Terminals
1 and 2	Close trigger switch
2	3
3	1
4	2
6	Ring-tong terminal

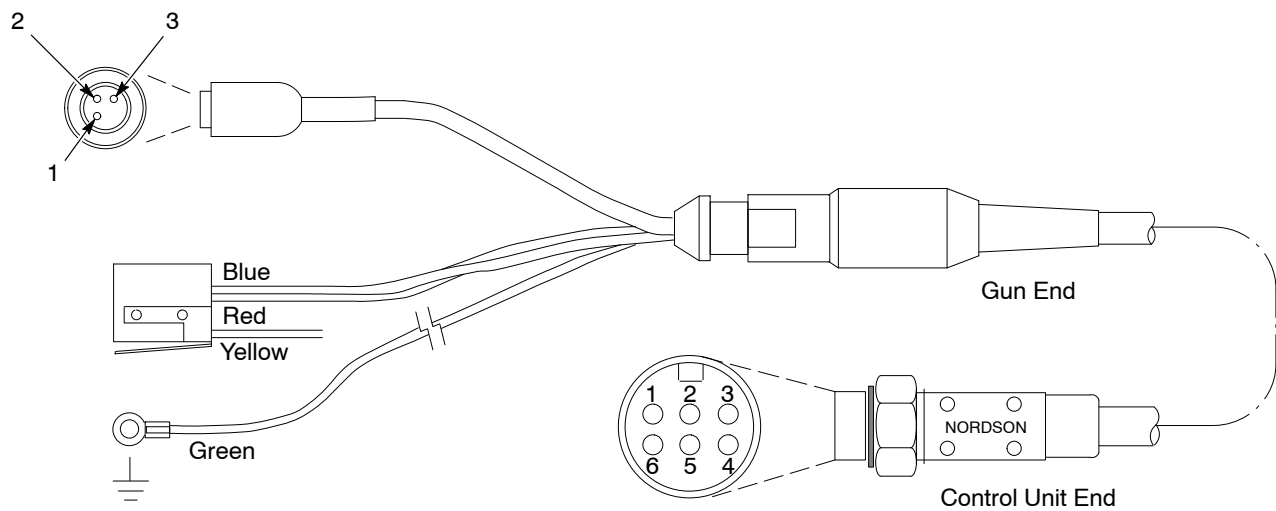

Figure 6 Gun Cable Continuity Checks

## Repair



**WARNING:** Allow only qualified personnel to perform the following tasks. Follow the safety instructions in this document and all other related documentation.

### ***Multiplier Replacement***

The multiplier service kit contains a new multiplier/resistor probe assembly and extension. Follow the steps below to replace your old multiplier with a new multiplier/resistor probe assembly.

1. Remove and clean the powder path parts as described in the *Daily Maintenance* procedure on page 6.
2. See Figure 7. Loosen the three captive screws (8) in the cover (7). The O-rings (6) hold the screws in the cover. Lift the cover off the handle (1).
3. Remove the screw (15) securing the multiplier heat sink bracket to the hanger (17). Remove the cable ground wire.
4. Loosen the connector swivel nut and disconnect the cable (13) from the multiplier connector (14).
5. Remove the extension (3) and multiplier/resistor probe assembly (16) from the handle.
6. Loosen and remove the cable nut (4). Use a wrench if necessary.
7. Remove the multiplier/resistor probe assembly from the extension.
8. If you are replacing the old extension with the new one included in the kit, remove the two screws (5) that secure the hanger (17) to the extension and remove the hanger. Install the hanger on the new extension.
9. Perform the disassembly steps in reverse to install the new multiplier/resistor probe assembly in your spray gun.

### ***Cable Replacement***

1. Remove the cover from the handle and disconnect the cable from the multiplier as described in the *Multiplier Replacement* procedure.
2. See Figure 7. Remove the two screws (9), lock washers (10) and flat washers (11). Remove the trigger switch and actuator (12) from the handle (1).
3. Rotate the hose bracket (2) slightly and release the cable. Note how the cable fits into the hose bracket.
4. Fit the new cable into the hose bracket and route the ground wire around the end of the multiplier. Secure the ground wire to the hanger (17) with the screw (15).
5. Connect the cable to the multiplier connector (14). Arrange the wiring so that it will not be pinched between the handle and the cover when the cover is installed.
6. Install the actuator on the trigger switch. Secure both to the two threaded inserts in the handle with the screws and washers.
7. Install the cover (7) on the handle.



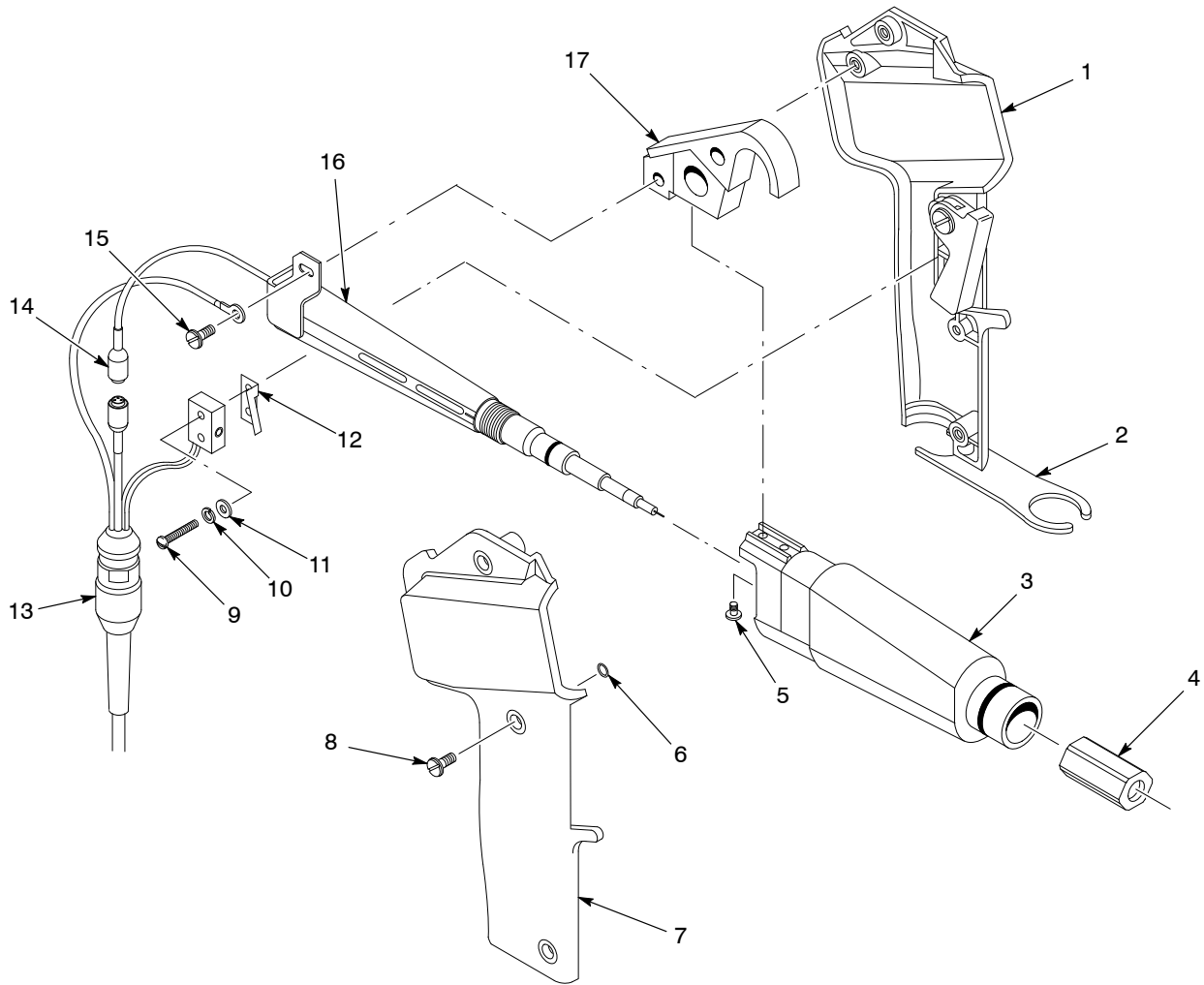

Figure 7 Multiplier and Cable Replacement

- |                 |                       |  |
|-----------------|-----------------------|--|
| 1. Handle       | 7. Cover              | 13. Cable                              |
| 2. Hose bracket | 8. Captive screws (3) | 14. Multiplier connector               |
| 3. Extension    | 9. Screws (2)         | 15. Screw (1)                          |
| 4. Cable nut    | 10. Lock washers (2)  | 16. Multiplier/resistor probe assembly |
| 5. Screws (2)   | 11. Flat washers (2)  | 17. Hanger                             |
| 6. O-rings (3)  | 12. Actuator          |  |

### Contact Tip Replacement

1. Remove and clean the powder path parts as described in the *Daily Maintenance* procedure on page 6.
2. See Figure 8. Unscrew the damaged contact tip (1) from the end of the resistor probe (2).
3. Apply dielectric grease to the threads of the new contact tip and into the end of the probe.
4. Screw the new contact tip into the resistor probe. Do not overtighten. Wipe excess grease off the contact tip and multiplier.

## Resistor Replacement

Resistor service kits contain a new resistor, holder, and contact tip. They are assembled, greased, and ready to be installed on a multiplier. A 3-cc applicator filled with dielectric grease is included.

1. Remove the multiplier/resistor probe assembly from the extension as described in the *Multiplier Replacement* procedure.
2. See Figure 8. Unscrew the old resistor probe (2) from the multiplier (4). Clean the multiplier well (5).
3. Remove the shipping container and protective caps from the new probe.



**WARNING:** All air in the multiplier well, resistor holder, and contact tip must be replaced by dielectric grease. High voltage can arc through air pockets, affect electrostatic performance, possibly burn through the spray gun, and create a fire or explosion hazard.

4. Inject dielectric grease into the multiplier well (5) until it is completely full. Use the 3-cc applicator supplied with the kit.
5. Fill the new resistor spring (3) and the resistor probe cavity (6) completely with dielectric grease.
6. Unscrew the contact tip (1) from the resistor probe (2).
7. Screw the new resistor probe onto the multiplier. Do not overtighten.
8. Apply dielectric grease to the threads of the new contact tip and into the end of the probe.
9. Screw the contact tip into the resistor probe. Do not overtighten. Wipe excess grease off the contact tip and multiplier.
10. Install the probe and multiplier into the extension and secure them with the cable nut. Connect the cable to the multiplier and assemble the spray gun.

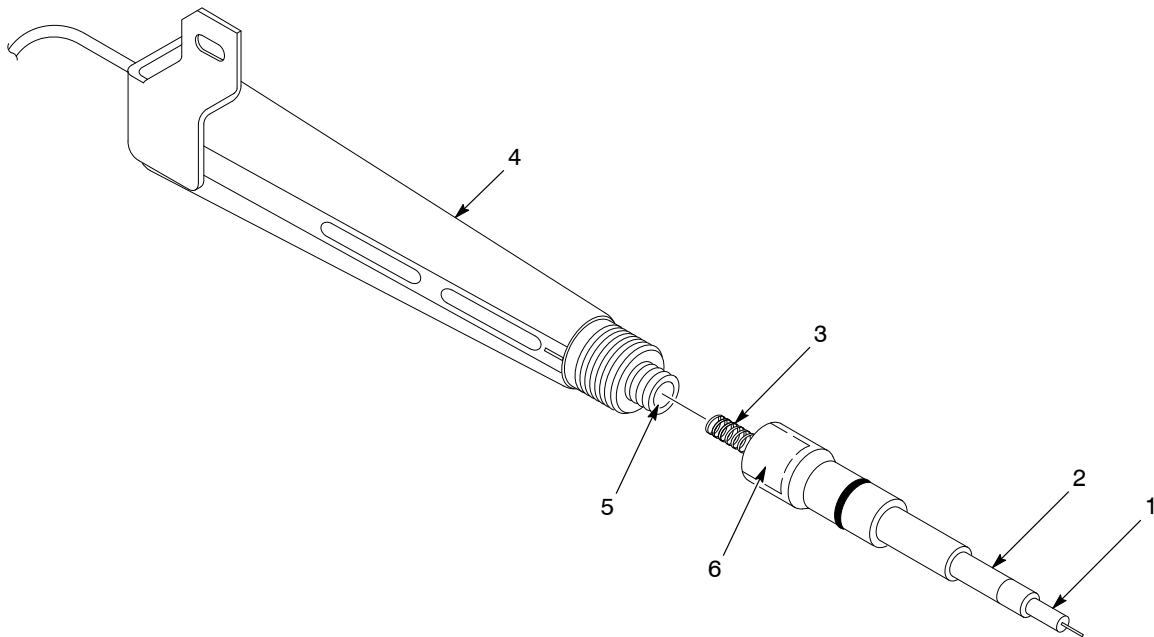

Figure 8 Contact Tip and Resistor Replacement

- |                   |                    |                          |
|-------------------|--------------------|--------------------------|
| 1. Contact tip    | 3. Resistor spring | 5. Multiplier well       |
| 2. Resistor probe | 4. Multiplier      | 6. Resistor probe cavity |

Note: Clean item 5, grease items 1, 3, 5, and 6.

## Parts

To order parts, call the Nordson Industrial Coating Systems Customer Support Center at (800) 433-9319 or contact your local Nordson representative. Use the parts lists and illustrations to locate and describe parts correctly.

### *Using the Illustrated Parts List*

Numbers in the Item column correspond to numbers that identify parts in illustrations following each parts list. The code NS (not shown) indicates that a listed part is not illustrated. A dash (—) is used when the part number applies to all parts in the illustration.

The number in the Part column is the Nordson Corporation part number. A series of dashes in this column (- - - -) means the part cannot be ordered separately.

The Description column gives the part name, as well as its dimensions and other characteristics when appropriate. Indentions show the relationships between assemblies, subassemblies, and parts.

- If you order the assembly, items 1 and 2 will be included.
- If you order item 1, item 2 will be included.
- If you order item 2, you will receive item 2 only.

The number in the Quantity column is the quantity required per unit, assembly, or subassembly. The code AR (As Required) is used if the part number is a bulk item ordered in quantities or if the quantity per assembly depends on the product version or model.

Letters in the Note column refer to notes at the end of each parts list. Notes contain important information about usage and ordering. Special attention should be given to notes.

Item	Part	Description	Quantity	Note
—	0000000	Assembly	1	
1	000000	• Subassembly	2	A
2	000000	• • Part	1	

## Gun Parts

See Figure 9.

Item	Part	Description	Quantity	Note
—	1069820	GUN, manual, Vantage, 6 meter	1	
1	125616	• HANGER, handgun, modular	1	
2	160103	• SERVICE KIT, handle	1	A
3	160104	• SERVICE KIT, trigger	1	A
4	132345	• BRACKET, cable/tube retaining	1	
5	982098	• SCREW, fillister head, slotted, M4 x 0.7 x 6	3	
6	-----	• CABLE, manual gun, Vantage, 6 meter	1	A
7	1070246	• SCREW, pan head, #2-56 x 0.437 in., slotted, zinc	2	
8	983113	• WASHER, lock, split, 2, steel, zinc	2	
9	983510	• WASHER, flat, 0.094 x 0.188 x 0.025 in., brown	2	
10	132336	• ACTUATOR, switch	1	
11	982327	• SCREW, cheese head, slotted, M4 x 12, zinc	1	
12	1014038	• KIT, multiplier, with resistor probe	1	A
13	125613	• • EXTENSION	1	
14	940243	• O-RING, silicone, 1.125 x 1.250 x 0.063 in.	1	
15	984165	• NUT, cable retainer	1	
16	125612	• BODY, inlet, powder	1	
17	982455	• SCREW, set, M6 x 1.0 x 8, nylon, black	1	
18	134386	• ADAPTER, hose, with O-ring, universal	1	
19	940163	• • O-RING, silicone, 0.625 x 0.750 x 0.063 in.	1	
20	173138	• DEFLECTOR, 19 mm, with O-ring	1	
21	940084	• • O-RING, silicone, 0.188 x 0.312 x 0.063 in.	1	
22	173139	• NOZZLE, short, with O-ring	1	
23	941181	• • O-RING, silicone, 0.875 x 1.063 x 0.094 in.	2	
24	132348	• SLEEVE, wear, conical	1	
25	141044	• SERVICE KIT, flat spray nozzle, 4 mm	1	
26	141045	• • NOZZLE, flat spray, 4 mm, with O-ring	1	
27	941181	• • • O-RING, silicone, 0.875 x 1.063 x 0.094 in.	2	
28	134385	• • SLEEVE, wear, flat spray, with O-ring	1	
NS	1083221	CABLE, handgun, 6 meter extension	1	B

NOTE A: Refer to *Service Kits* in this section for contents of kits. Some parts in kits can be ordered separately.

B: Optional 6-meter extension cable. Do not add more than two extension cables to the gun cable.

NS: Not Shown

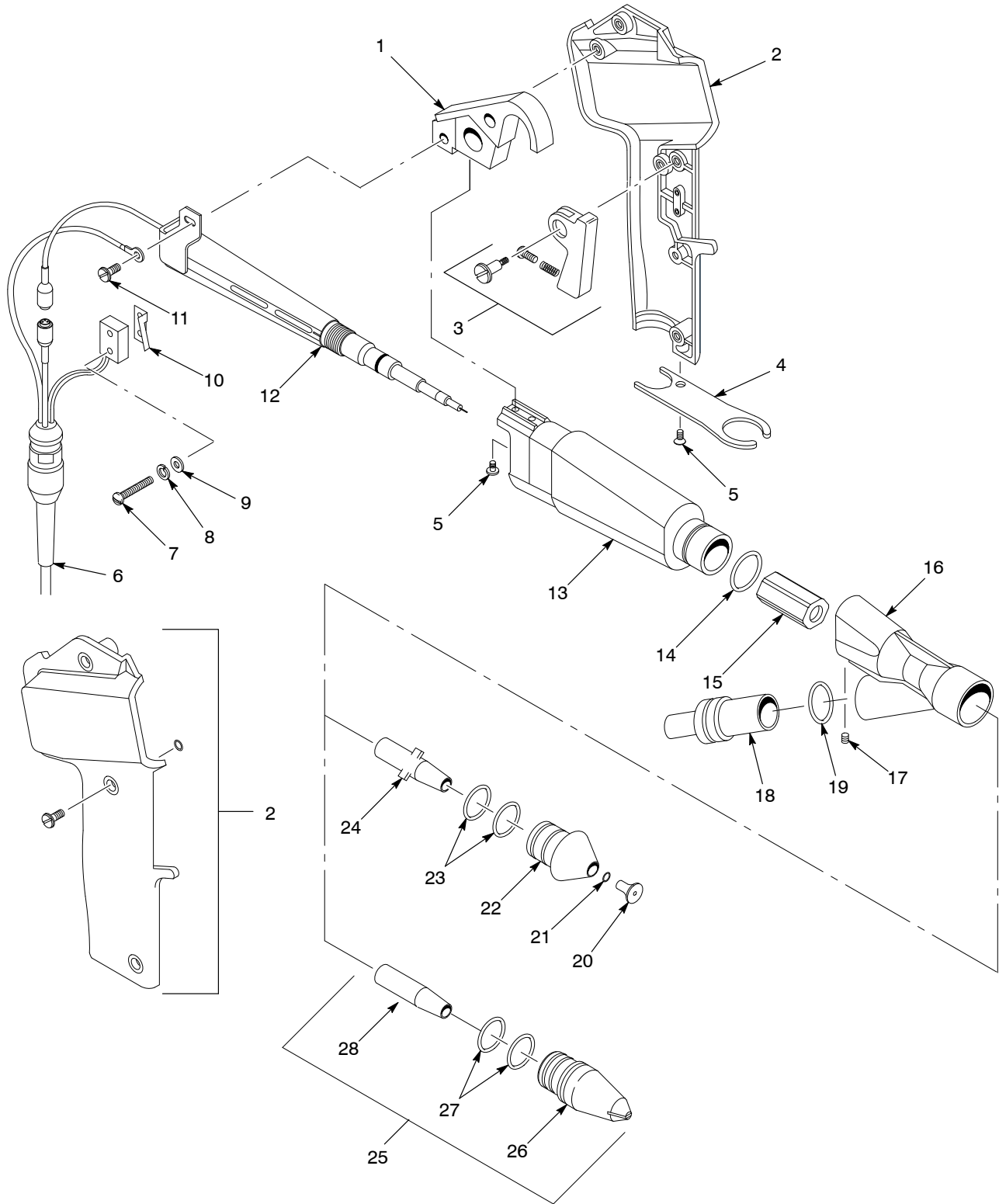

Figure 9 Gun Parts

## Service Kits

### Cable Service Kit

See Figure 10.

Item	Part	Description	Quantity	Note
—	1064928	SERVICE KIT, cable, 6 meter	1	
1	-----	• CABLE	1	
2	132336	• ACTUATOR, switch	1	
3	1070246	• SCREW, pan head, #2-56 x 0.437 in., slotted, zinc	2	
4	983113	• WASHER, lock, split, 2, steel, zinc	2	
5	983510	• WASHER, flat, 0.094 x 0.188 x 0.025 in., brown	2	

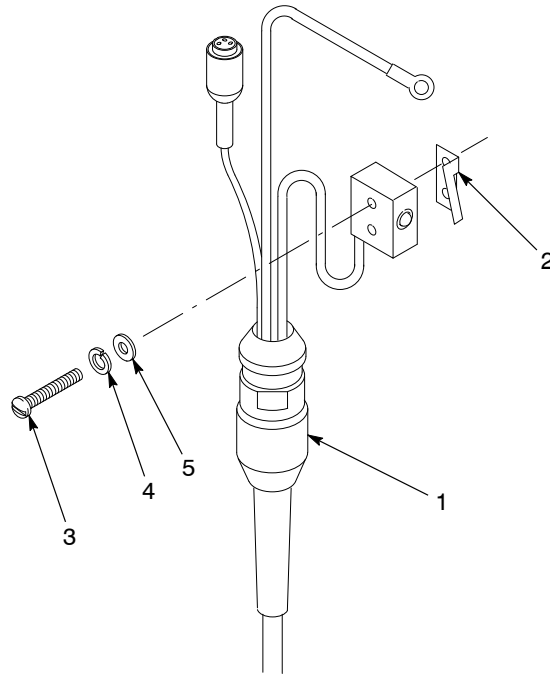

Figure 10 Cable Service Kit

### Multiplier Service Kits

See Figure 11. Multiplier kits include the resistor, multiplier, and extension. If replacing just the resistor, order the *Resistor Service Kit*.

Item	Part	Description	Quantity	Note
—	1014038	SERVICE KIT, negative multiplier, 80 kV, with resistor probe	1	A
—	1014039	SERVICE KIT, positive multiplier, 80 kV, with resistor probe	1	B
1	-----	• MULTIPLIER, 80 kV	1	
2	134376	• SERVICE KIT, holder, resistor	1	
3	125613	• EXTENSION	1	

NOTE A: Standard multiplier shipped with the spray gun.

B: Optional multiplier used to give powder particles a positive charge. Contact your Nordson representative or powder supplier for more information.

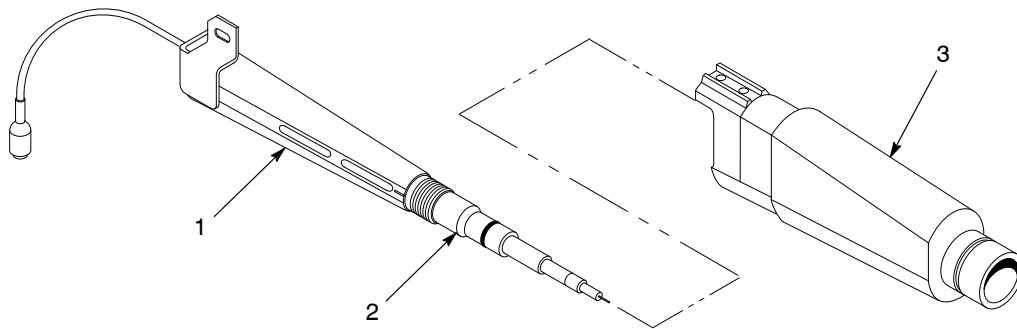

Figure 11 Multiplier Service Kits

### Resistor Service Kit

See Figure 12.

Item	Part	Description	Quantity	Note
—	134376	SERVICE KIT, holder, resistor	1	
1	132748	• CONTACT, cable	1	
2	940117	• O-RING, silicone, 0.312 x 0.438 x 0.063 in.	1	
3	-----	• HOLDER, resistor	1	
4	-----	• RESISTOR	1	
NS	245733	• GREASE, dielectric, 3-cc applicator	1	

NS: Not Shown

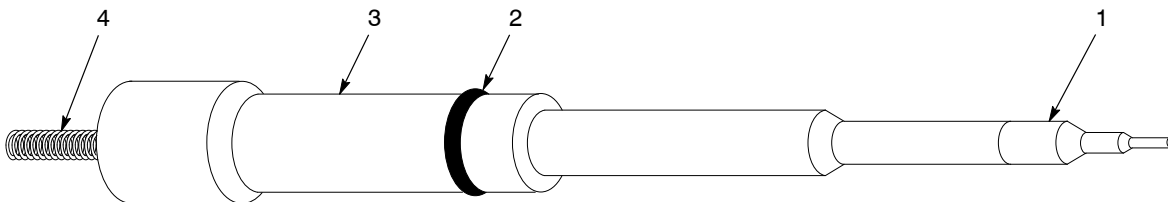

Figure 12 Resistor Service Kit

## Handle Service Kit

See Figure 13.

Item	Part	Description	Quantity	Note
1	160103	SERVICE KIT, handle	1	A
2	-----	• HANDLE, gun	1	
3	-----	• HANDLE, cover	1	
4	940060	• O-RING, Viton, 0.125 x 0.250 x 0.063 in.	3	
5	981626	• SCREW, captive, slotted, M4 x 12, black	3	

NOTE A: Customer must provide spray gun part number and serial number when ordering.

## Trigger Service Kit

See Figure 13.

Item	Part	Description	Quantity	Note
6	160104	SERVICE KIT, trigger	1	
7	132334	• PIVOT, trigger	1	
8	125617	• TRIGGER, hand gun, modular	1	
9	133783	• SPRING, trigger, return	1	
10	982370	• SCREW, pan head, slotted, M2 x 5	1	

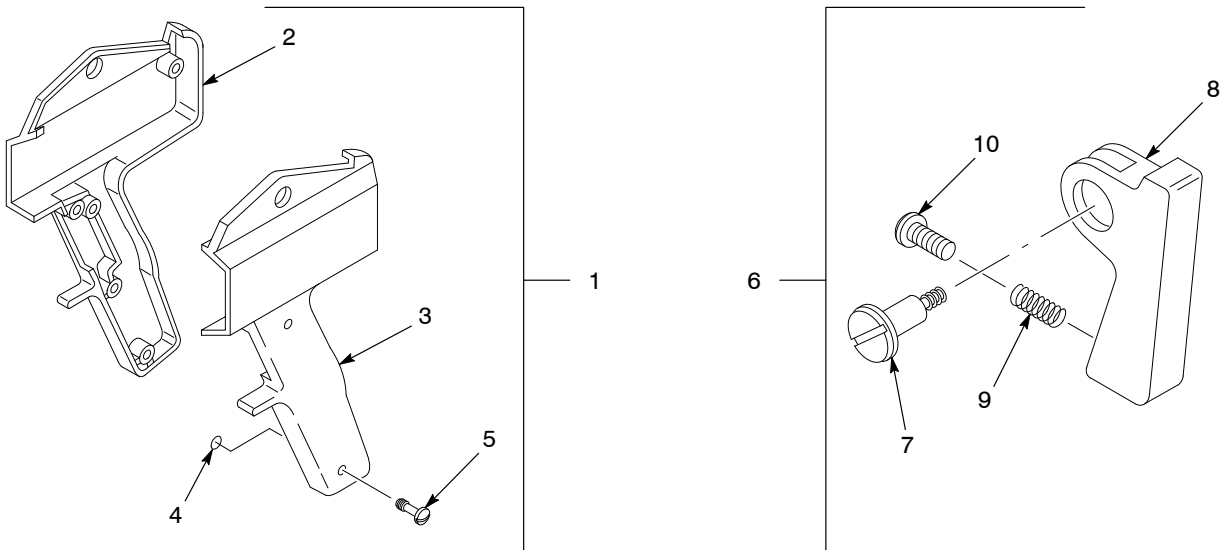

Figure 13 Handle and Trigger Service Kits



## Shorting Plug

See Figure 14.

Item	Part	Description	Quantity	Note
1	161411	PLUG, shorting, IPS	1	

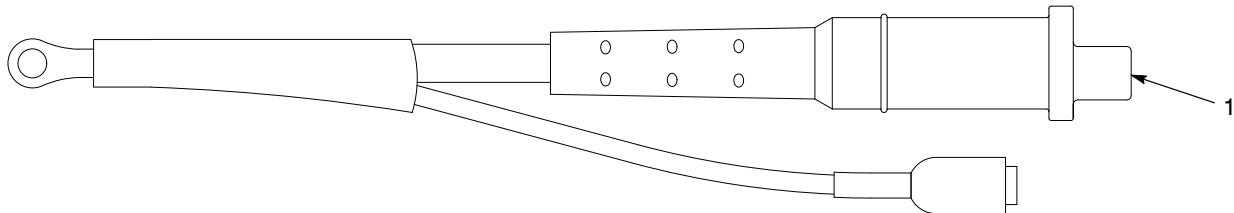

Figure 14 Shorting Plug

## Powder Feed Hose

These are bulk part numbers. Order in one-foot increments.

Part	Description	Note
900650	POWDER TUBING, 12.7 mm ( $1/2$ in.) OD, blue	
900648	POWDER TUBING, 11 mm ID, blue	
900649	POWDER TUBING, 9.5 mm ( $3/8$ in.) ID, blue	

## Options

Contact your Nordson representative for more information about these options.

### Option Descriptions

Option	Description
Nozzles and Deflectors	Nozzles and deflectors are available in a variety of sizes and configurations. Refer to <i>Optional Nozzles</i> for information about the applications and parts for each nozzle.
Lance Extensions	Lance extensions are used to extend the length of the powder path to help spray powder into recesses and interior corners. The extensions are equipped with 26-mm conical nozzles and are available in 150-, 300-, and 450-mm (6-, 12-, and 18-in.) lengths.
Ion Collector Kits	The ion collector can improve the smoothness and appearance of cured powder coatings. It collects ions emitted from the spray gun's charging electrode instead of allowing them to deposit on the part. This can reduce the rate of charge buildup in the powder deposited on the part, which may reduce defects in the cured coating such as pinholing and orange peel.  Three kits are available: one for standard spray guns, and two for guns with 150- or 300-mm lance extensions.
Cup Gun Kit	The cup gun kit attaches directly to the gun and is used to test small amounts of powder when a full-sized hopper is unnecessary.
6-Meter Gun Cable Extension	Extends the 6-meter gun cable by 6 meters. Up to two 6-meter extension cables may be added.

## Option Part Numbers

The lance extension, ion collector, and cup gun kits are shipped with an instruction sheet that contains installation procedures and replacement parts.

Part	Description
<b>Conical Nozzles</b>	
173139	SHORT NOZZLE, with O-rings
145559	32-mm CONICAL NOZZLE service kit, with O-rings, Tivar
144760	45-mm CONICAL NOZZLE service kit, with O-rings, Tivar
-----	DEFLECTORS, Tivar, in different diameters, with O-rings
<b>Flat-Spray Nozzles</b>	
134380	2.5-mm FLAT-SPRAY NOZZLE service kit, with O-rings, Tivar
139935	3-mm FLAT-SPRAY NOZZLE service kit, with O-rings, Tivar
141044	4-mm FLAT-SPRAY NOZZLE service kit, with O-rings, Tivar
139937	6-mm FLAT-SPRAY NOZZLE service kit, with O-rings, Tivar
<b>Cross-Cut and Castle Nozzles</b>	
141013	60° CROSS-CUT NOZZLE service kit, Tivar
141014	90° CROSS-CUT NOZZLE service kit, Tivar
147495	CASTLE NOZZLE service kit, 0.375 in.
<b>Lance Extensions</b>	
233469	150-mm LANCE EXTENSION
233468	300-mm LANCE EXTENSION
233455	450-mm LANCE EXTENSION
<b>Ion Collectors</b>	
189492	KIT, handgun, ion collector
189493	KIT, 150-mm lance, ion collector
189494	KIT, 300-mm lance, ion collector
<b>Miscellaneous Options</b>	
183468	KIT, cup gun
1083221	CABLE, manual gun, 6 meter extension

## Optional Nozzles

### Flat-Spray Nozzle Selection

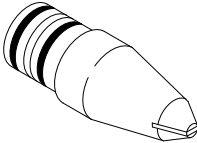
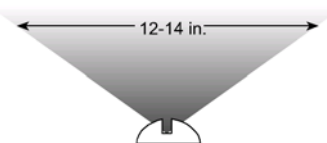
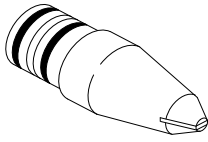
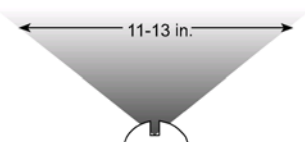
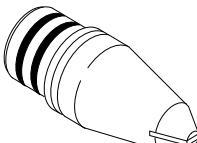
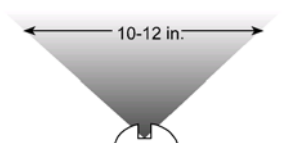
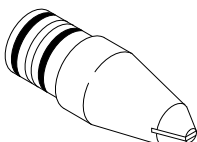
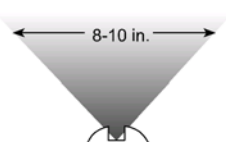
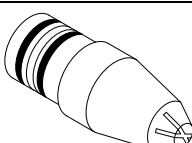
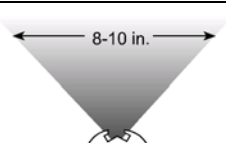
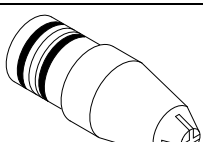
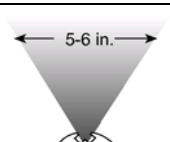
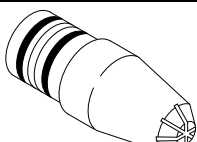
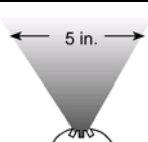
Nozzle	Spray Pattern	Powder Velocity	Application
2.5-mm Flat Spray 		High	Large, flat surfaces
3-mm Flat Spray 		Medium-high	Fine finish on flat surfaces
4-mm Flat Spray 		Medium-low	Touch up
6-mm Flat Spray 		Low	Reinforcement
60° Cross-Cut 		Medium-low	Recess reinforcement
90° Cross-Cut 		Low	Deep recesses
Castle 		Medium-low	Pin point

### Flat-Spray Nozzle Parts

Nozzle	Part Number	
	Nozzle, O-Rings, and Wear Sleeve	Nozzle with O-rings
2.5-mm	134380	134384
4-mm	141044	141045
3-mm	139935	139902
6-mm	139937	139903
60° Cross-Cut	141013	141017
90° Cross-Cut	141014	141015
Castle	147495	147877

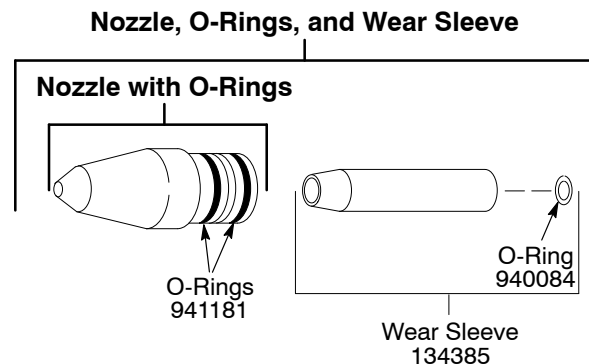

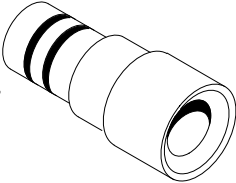
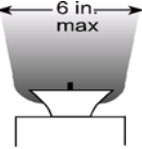
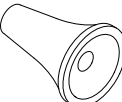
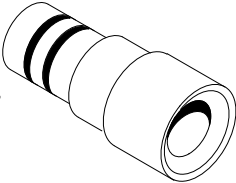
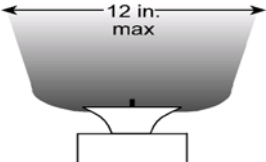

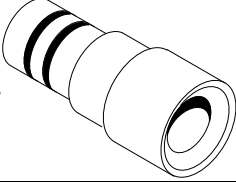
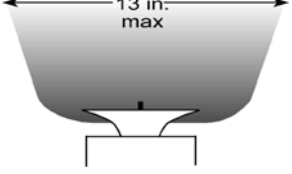

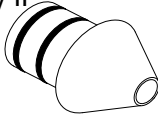
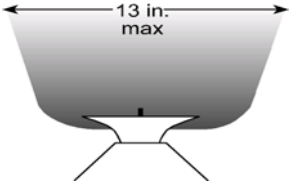

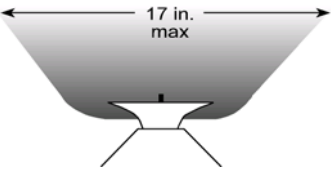

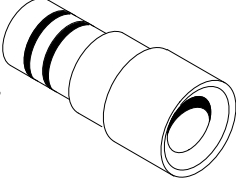
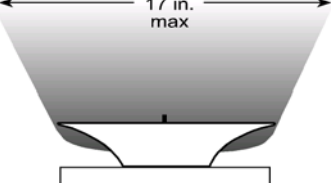

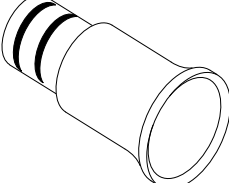
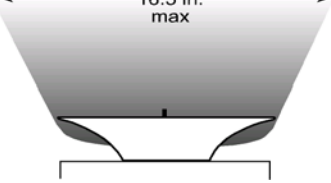

Figure 15 Common Flat-Spray Nozzle Parts

### Conical Nozzle and Deflector Selection

Deflector Size	Used with This Nozzle	Spray Pattern	Powder Velocity	Application
14 mm 	32 mm with pattern adjuster 		High	Manual touch-up
16 mm 	32 mm with pattern adjuster 		Medium-high	General finishing
19 mm 	32 mm with pattern adjuster 		Medium	Large surfaces
19 mm 	Short Versa-Spray II 		Medium	Large surfaces
26 mm 	Short Versa-Spray II 		Medium-low	Parts with gaps and recesses
26 mm 	32 mm with pattern adjuster 		Medium-low	Parts with gaps and recesses
38 mm 	45 mm 		Low	Large surfaces

## Conical Nozzle and Deflector Parts

### 32-mm Conical Nozzle and Deflectors

See Figure 16.

Item	Part	Description	Quantity	Note
—	145559	SERVICE KIT, nozzle, 32 mm	1	
1	133734	• 26-mm DEFLECTOR, with O-ring, Tivar	1	
2	940084	• • O-RING, silicone, 0.188 x 0.312 x 0.063 in.	1	
3	144759	• ADJUSTER, pattern, 32 mm	1	
4	145558	• NOZZLE, 32-mm dia, with O-rings, Tivar	1	
5	941205	• • O-RING, silicone, 1.000 x 1.188 x 0.094 in.	1	
6	941181	• • O-RING, silicone, 0.875 x 1.063 x 0.094 in.	2	
7	132348	• SLEEVE, wear, conical, Tivar	1	
<b>Optional Deflectors</b>				
1	135865	14-mm DEFLECTOR, Tivar, with O-ring	1	
1	147880	16-mm DEFLECTOR, Tivar, with O-ring	1	
1	133714	19-mm DEFLECTOR, Tivar, with O-ring	1	
2	940084	• O-RING, silicone, 0.188 x 0.312 x 0.063 in.	1	A

NOTE A: This O-ring is included with all deflectors.

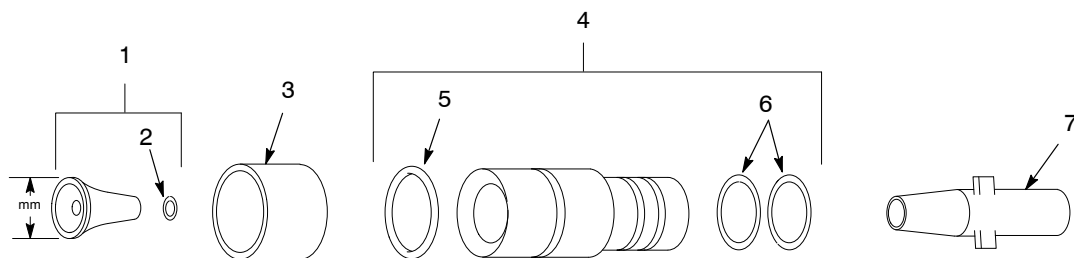

Figure 16 32-mm Conical Nozzle and Deflectors

**45-mm Conical Nozzle and Deflector**

See Figure 17.

Item	Part	Description	Quantity	Note
—	144760	SERVICE KIT, nozzle, 45 mm	1	
1	249233	• 38-mm DEFLECTOR, with O-ring, Tivar	1	
2	940084	• • O-RING, silicone, 0.188 x 0.312 x 0.063 in.	1	
3	144789	• NOZZLE, 45-mm diameter, with O-rings	1	
4	941181	• • O-RING, silicone, 0.875 x 1.063 x 0.094 in.	2	
5	132348	• SLEEVE, wear, conical, Tivar	1	

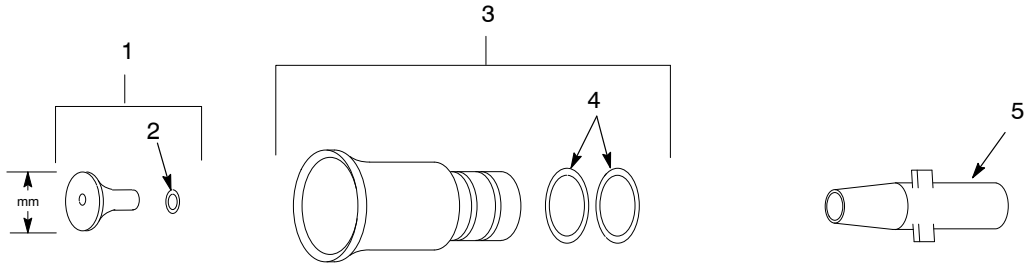

Figure 17 45-mm Conical Nozzle and Deflector

**Short Conical Nozzle and Deflectors**

See Figure 18.

Item	Part	Description	Quantity	Note
1	173138	19-mm DEFLECTOR, with O-ring, Tivar	1	
1	173141	26-mm DEFLECTOR, with O-ring, Tivar	1	
2	940084	• O-RING, silicone, 0.188 x 0.312 x 0.094 in.	1	A
3	173139	NOZZLE, short, with O-rings	1	
4	941181	• O-RING, silicone, 0.875 x 1.063 x 0.094 in.	2	
5	132348	SLEEVE, wear, conical	1	

NOTE A: This O-ring is included with all deflectors.

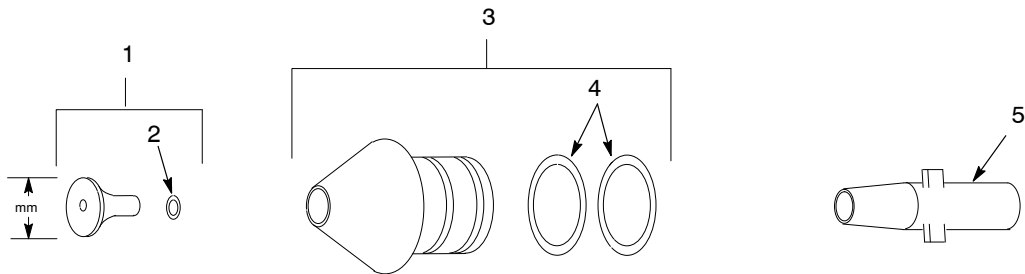

Figure 18 Short Conical Nozzle and Deflectors