

Standard and Low-Flow Metric Powder Feed Pumps

Introduction

Standard and low-flow metric powder feed pumps are used to deliver organic and metallic powder coatings to powder spray guns. These pumps have fittings for metric-sized air tubing (6 or 8 mm).

These are venturi-type pumps with flow rate and atomizing air nozzles. Flow rate air lifts fluidized powder from a feed hopper and forces the powder and air mixture through the feed tubing to the spray guns. Atomizing air dilutes and atomizes the powder stream as it exits the pump.

Pump Versions

Standard Pumps: Used with most general powder coating applications.

Low-Flow Pumps: Used when the desired powder flow is below 10 kg/hr (22 lb/hr) and the feed hose is typically not longer than 4 m (13 ft).

Refer to Table 1 for pump information. The pumps come with quick-disconnect air fittings for either 8 or 6-mm air tubing.

The pumps are shipped with SMART™ engineered plastic venturi throats with integral seals and retainer. Optional throats made from other materials are available for special applications. Refer to page 7 for part numbers.

Air tubing and powder feed hoses are optional. Refer to page 10 for part numbers.

Table 1 Standard and Low-Flow Metric Powder Feed Pumps

Pump Type	Part Number	Powder Feed Hose ID	Control Unit Compatibility		
			AeroCharge	Sure Coat	Versa-Spray
8-mm standard	327742	13-mm (1/2-in.)		✓	
8-mm low-flow	1011129	9.5-mm (3/8-in.)	✓	✓	
6-mm standard	165636	13-mm (1/2-in.)			✓
6-mm low-flow	165637	9.5-mm (3/8-in.)			✓

Optional Pump Mounting Kits

Refer to the following pages for ordering, installation, and parts information:

Top-Mount Pump Mounting Kits: Page 7

Side-Mount Pump Mounting Kit: Page 9

Installation







WARNING: All conductive equipment in the spray area must be connected to a true earth ground. Ungrounded or poorly grounded equipment used in a powder spray area can become electrically charged. This charge can deliver a severe shock, or create sparks hot enough to cause a fire or explosion.

1. The pump mounting kits include pick-up tubes. Install the mounting kits on the hopper lid or side as shown in Figures 3 or 4.
2. Install the pump on the adapter with a slight twisting motion.

NOTE: The pump adapter O-rings are conductive silicone, to establish a ground connection between the pump body and the hopper. Do not replace these O-rings with non-conductive O-rings.

3. Refer to Table 2 for air tubing color codes. Connect air tubing to the pump fittings and route the tubing to the gun controller output fittings.

Table 2 Air Tubing Connections

Air	Spray Gun Controller Air Function Symbols		Color Tubing	Pump Fitting Label
	AeroCharge, Sure Coat	100 PLUS, Tribomatic, Versa-Spray		
Atomizing			Blue	A
Flow-Rate			Black	F

4. Connect the powder feed hose to the pump outlet and secure it with a hose clamp. If necessary, install a short length of spiral-cut tubing around the feed hose at the pump outlet to prevent it from kinking and cutting off the flow of powder.

NOTE: For best results, the powder feed hose should be no longer than 7.6 m (25 ft) and rise vertically over its length no more than 2.7 m (9 ft).

Operation

Typical operating pressures are:

Atomizing: 1.4 bar (20 psi)

Flow Rate: 2.1 bar (30 psi)

These pressures are average starting points. They can be adjusted higher or lower to achieve the desired delivery volume and cloud density.

Maintenance



WARNING: Allow only qualified personnel to perform the following tasks. Follow the safety instructions in this document and all other related documentation.

Daily

Disconnect the powder feed hose and atomizing and flow rate air tubing and blow out the pump with compressed air.

Blow out the powder feed hose with compressed air. Always blow out the feed hose from the pump end into the booth, not from the spray gun end into the pump. Make sure the booth exhaust fan is running.

Periodically



WARNING: Do not replace conductive O-rings with non-conductive O-rings. Conductive O-rings provide a path to ground that is required for powder spray equipment. Failure to observe this warning could result in personal injury, fire, or explosion.



CAUTION: Do not scrape impact-fused powder off the pump parts with any sharp metal tools. Powder will build up in any scratches on the powder contact surfaces, causing impact-fusion and pump clogging.

Disassemble the pumps and clean the parts with low-pressure compressed air and clean, lint-free cloths. The parts may be wiped clean with a non-toxic solvent such as alcohol after removing the O-rings. The O-rings could be damaged by the solvent.

Inspect all parts and replace any that are worn or damaged.

Inspect the powder feed hoses and replace any hose that are worn or damaged. Replace the feed hose if impact fusion is present on the inner walls.

Parts

To order parts, call the Nordson Finishing Customer Support Center at (800) 433-9319 or your local Nordson representative.

Standard Pump, 8 mm

See Figure 1.

Item	Part	Description	Quantity	Note
—	327742	PUMP, powder, standard-flow, metric, 8 mm, packaged	1	
1	972276	• ELBOW, male, 8-mm tube x 1/8 in. unithread	2	
2	248124	• MARKER, clip, F	1	
3	248046	• MARKER, clip, A	1	
4	249503	• NOZZLE, air, venturi, 0.063-in. ID	2	
5	940129	• O-RING, silicone, conductive, 0.375 x 0.50 x 0.063 in.	4	
6	249502	• HOUSING, pump, powder	1	
7	973402	• PLUG, pipe, socket, flush, 1/8 in., zinc	1	
8	1064256	• THROAT, venturi, SMART™	1	A
9	940163	• O-RING, silicone, 0.625 x 0.75 x 0.063 in.	1	
10	249506	• HOLDER, throat	1	
11	940184	• O-RING, silicone, conductive, 0.75 x 0.875 x 0.063 in.	1	
12	249507	• TUBE, wear, holder	1	

NOTE A: This throat does not require O-rings and retaining ring. Refer to page 8 for optional throats.

Standard Pump, 6 mm

See Figure 1.

Item	Part	Description	Quantity	Note
—	165636	PUMP, powder, standard-flow, metric, 6 mm, packaged	1	
1	972126	• ELBOW, male, 6-mm tube x 1/8 in. unithread	2	
2	939109	• MARKER, clip, F	1	
3	939108	• MARKER, clip, A	1	
4	249503	• NOZZLE, air, venturi, 0.063-in. ID	2	
5	940129	• O-RING, silicone, conductive, 0.375 x 0.50 x 0.063 in.	4	
6	249502	• HOUSING, pump, powder	1	
7	973402	• PLUG, pipe, socket, flush, 1/8 in., zinc	1	
8	1064256	• THROAT, venturi, SMART™	1	A
9	940163	• O-RING, silicone, 0.625 x 0.75 x 0.063 in.	1	
10	249506	• HOLDER, throat	1	
11	940184	• O-RING, silicone, conductive, 0.75 x 0.875 x 0.063 in.	1	
12	249507	• TUBE, wear, holder	1	

NOTE A: This throat does not require O-rings and retaining ring. Refer to page 8 for optional throats.

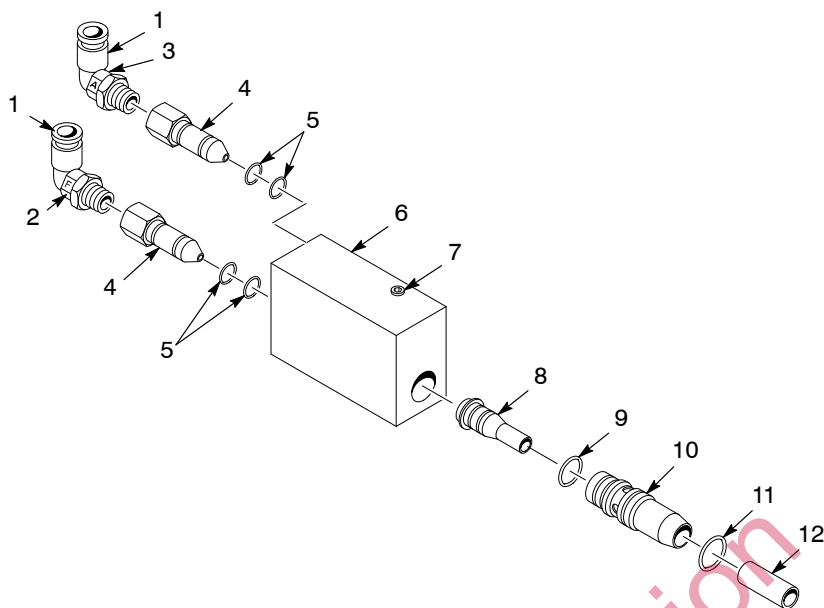

1400458B

Figure 1 Standard 6 and 8-mm Pump Parts

Low-Flow Pump, 8 mm

See Figure 2.

Item	Part	Description	Quantity	Note
—	1011129	PUMP, powder, low-flow, metric, 8 mm, packaged	1	
1	972276	• ELBOW, male, 8-mm tube x 1/8 in. unithread	2	
2	248124	• MARKER, clip, F	1	
3	248046	• MARKER, clip, A	1	
4	249503	• NOZZLE, air, venturi, 0.063 in. ID	2	
5	940129	• O-RING, silicone, conductive, 0.375 x 0.50 x 0.063 in.	4	
6	249502	• HOUSING, pump, powder	1	
7	973402	• PLUG, pipe, socket, flush, 1/8 in., zinc	1	
8	1064257	• THROAT, venturi, low-flow, SMART™	1	A
9	940163	• O-RING, silicone, 0.625 x 0.75 x 0.063 in.	1	
10	249506	• HOLDER, throat	1	
11	940184	• O-RING, silicone, conductive, 0.75 x 0.875 x 0.063 in.	1	
12	139943	• CONNECTOR, pump, powder	1	

NOTE A: This throat does not require O-rings and retaining ring. Refer to page 8 for optional throats.

Low-Flow Pump, 6 mm

See Figure 2.

Item	Part	Description	Quantity	Note
—	165637	PUMP, powder, low-flow, metric, 6 mm, packaged	1	
1	972126	• ELBOW, male, 6-mm tube x 1/8 in. unithread	2	
2	939109	• MARKER, clip, F	1	
3	939108	• MARKER, clip, A	1	
4	249503	• NOZZLE, air, venturi, 0.063-in. ID	2	
5	940129	• O-RING, silicone, conductive, 0.375 x 0.50 x 0.063 in.	4	
6	249502	• HOUSING, pump, powder	1	
7	973402	• PLUG, pipe, socket, flush, 1/8 in., zinc	1	
8	1064257	• THROAT, venturi, low-flow, SMART™	1	A
11	940163	• O-RING, silicone, 0.625 x 0.75 x 0.063 in.	1	
12	249506	• HOLDER, throat	1	
13	940184	• O-RING, silicone, conductive, 0.75 x 0.875 x 0.063 in.	1	
14	139943	• CONNECTOR, pump, powder	1	

NOTE A: This throat does not require O-rings and retaining ring. Refer to page 8 for optional throats.

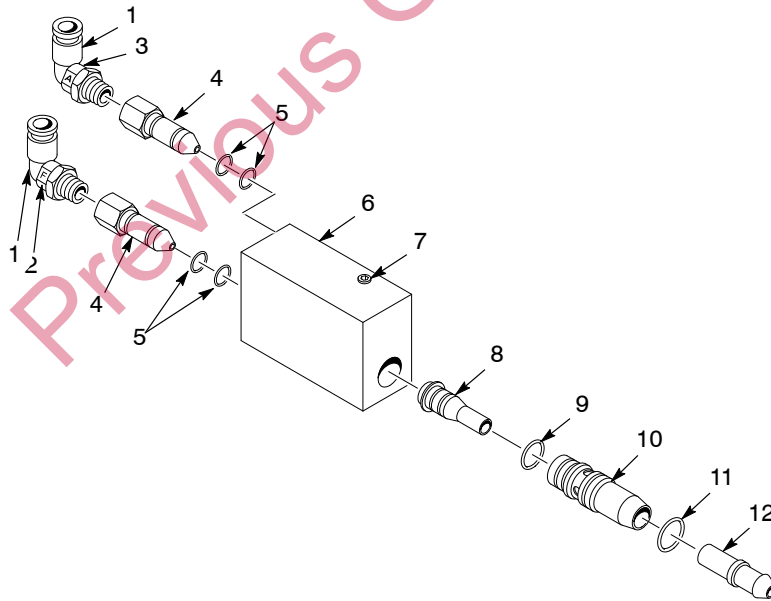

1400459A

Figure 2 Low-Flow 6 and 8-mm Pump Parts

Pump Options

Venturi Throats

Optional material venturi throats may exhibit better performance with certain powders.

Part	Description	Quantity	Note
249504	THROAT, venturi, PTFE (standard flow)	1	A, E
174215	THROAT, venturi, glass-filled PTFE (standard flow)	1	B, E
114223	THROAT, venturi, stainless steel (standard flow)	1	C, E
114221	THROAT, venturi, Tivar (standard flow)	1	D, E
109101	THROAT, venturi, PTFE, low-flow	1	A, E
174213	THROAT, venturi, glass-filled PTFE, low-flow	1	B, E
114219	THROAT, venturi, Tivar, low-flow	1	D, E
986100	• RETAINING RING, extension, 50, invert	1	E
940126	• O-RING, silicone, 0.375 x 0.50 x 0.063 in.	2	E

NOTE A: May exhibit less impact fusion with certain powder materials, but has a shorter wear life.
 B: May exhibit better wear life than a PTFE throat, and less impact fusion than a Tivar throat.
 C: Used in special applications with non-paint powdered materials.
 D: May exhibit better wear life, but more impact fusion, than a PTFE throat.
 E: All optional throats include these O-rings and retaining ring.

Top Mount Pump Mounting Kits

Pump Mounting Kit with 18-in. Pickup Tube

See Figure 3. Use this kit with the following hoppers:

- Model HRS-1 23-kg (50-lb) capacity
- Model HRS-2 23-kg (50-lb) capacity
- Model HR-2-50 23-kg (50-lb) capacity

NOTE: These hoppers include one mounting kit.

Item	Part	Description	Quantity	Note
—	163555	MOUNT, pump, with pick-up tube, 18 in.	1	
1	152227	• ADAPTER, pump	1	
2	941185	• O-RING, silicone, conductive, 0.875 x 1.062 in.	2	
3	164063	• MOUNT, pump	1	
4	941145	• O-RING, silicone, conductive, 0.625 x 0.812 in.	2	
5	164065	• TUBE, pick-up, 0.36 ID x 18 in.	1	
6	983055	• WASHER, pump mount	1	
7	939613	• LOCKNUT, conduit, $\frac{3}{4}$ in. NPS	1	

Pump Mounting Kit with 24-in. Pickup Tube

See Figure 3. Use this kit with the following hoppers:

- Model HR-2-80 36-kg (80-lb) capacity
- Model HR-8-80 36-kg (80-lb) capacity

NOTE: These hoppers include two mounting kits.

Item	Part	Description	Quantity	Note
—	163556	MOUNT, pump, with pick-up tube, 24 in.	1	
1	152227	• ADAPTER, pump	1	
2	941185	• O-RING, silicone, conductive, 0.875 x 1.062 in.	2	
3	164063	• MOUNT, pump	1	
4	941145	• O-RING, silicone, conductive, 0.625 x 0.812 in.	2	
5	152223	• TUBE, pick-up, 0.36 ID x 24 in.	1	
6	983055	• WASHER, pump mount	1	
7	939613	• LOCKNUT, conduit, ³ / ₄ in. NPS	1	

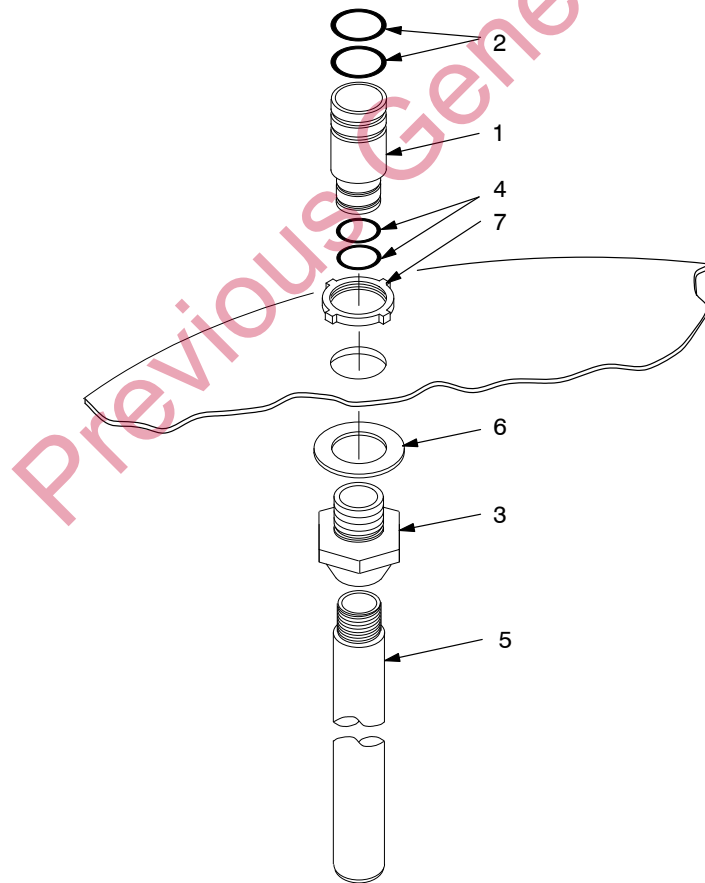

1400460A

Figure 3 Top Mount Pump Mounting Kit Installation and Parts

Side-Mount Pump Mounting Kit

Item	Part	Description	Quantity	Note
-	1051479	KIT, pump mount w/90-degree angled pickup tube	1	
1	114225	• MOUNT, pump	1	
2	941185	• O-RING, silicone, conductive, 0.875 x 1.062 in.	2	
3	942161	• O-RING, silicone, 1.125 x 1.375 x 0.125 in.	1	
4	142382	• NUT, ground, pump mount	1	
5	1051448	• TUBE, pickup, angled, 90 degrees	1	
6	939247	• CLAMP, hose, snap-it	1	

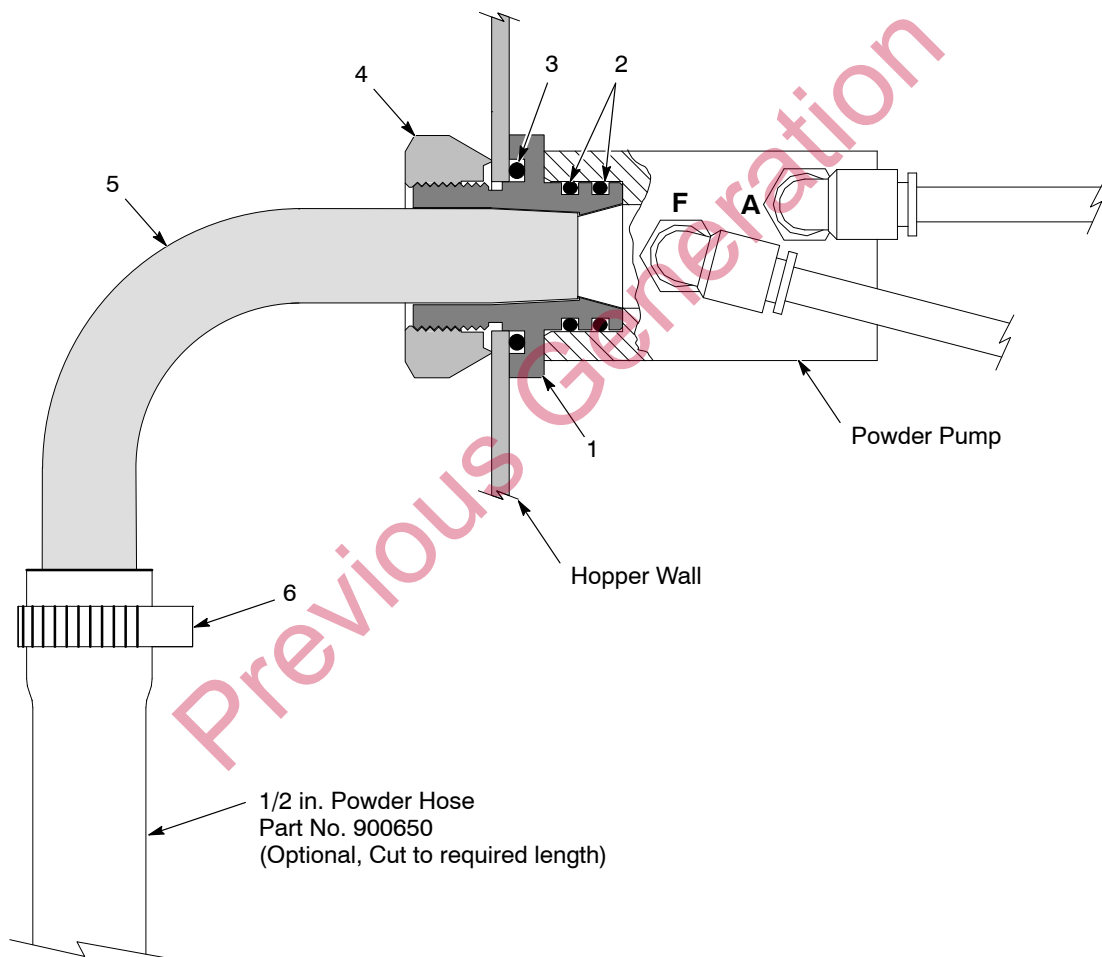

1401338A

Figure 4 Side Mount Pump Mounting Kit Installation and Parts

Air Tubing

Tubing is not included with pumps. It must be ordered in increments of one foot.

Part	Color	Material	Size, OD, mm	Usage
900615	Black	Polyethylene	6	flow-rate air
900586	Blue	Polyethylene	6	atomizing air
900741	Black	Polyurethane	6	flow-rate air
900742	Blue	Polyurethane	6	atomizing air
173102	Black	Polyethylene	8	flow-rate air
173101	Blue	Polyethylene	8	atomizing air
900619	Black	Polyurethane	8	flow-rate air
900618	Blue	Polyurethane	8	atomizing air

Powder Feed Tubing

Tubing is not included with pumps. It must be ordered in increments of one foot.

Part	Description	Note
900649	$\frac{3}{8}$ in. ID, blue	A
900648	$\frac{7}{16}$ in. ID, blue	A
900650	$\frac{1}{2}$ in. ID, blue	A
900549	$\frac{3}{8}$ in. ID, black	B
900550	$\frac{1}{2}$ in. ID, black	B

NOTE A: Recommended for use with metallics and most organic powders.
B: For organic powders.

Issued 8/05

Original copyright date 1994. AeroCharge, Nordson, the Nordson logo, Sure Coat, and Versa-Spray are registered trademarks of Nordson Corporation.

Tivar is a registered trademark of Poly-Hi Corporation.

All other trademarks are the property of their respective owners.