

NORDSON CORPORATION  
*Powder Coating Systems*



**Color Change Procedures**  
**ColorMax® Powder Booth with Spectrum® II Feed Center**  
**and Prodigy® HDLV® Powder Transfer System**

1066156A04





**WARNING:** Allow only qualified personnel to perform the following tasks. Follow the safety instructions in your powder coating equipment manuals.

Previous Generation

# Procedure 1

## OPERATOR A

1



Close the booth doors.  
Move the booth offline if it is a  
Roll On/Roll Off booth.

2



Blow off:

- door seams at the entrance end
- operator doors
- gun slots

Wait for gun purge to complete.

Go to page 12 to continue Operator A tasks.

# Procedure 2

OPERATOR B

1

Main Menu

Auto



2

Auto Menu

COLOR MENU

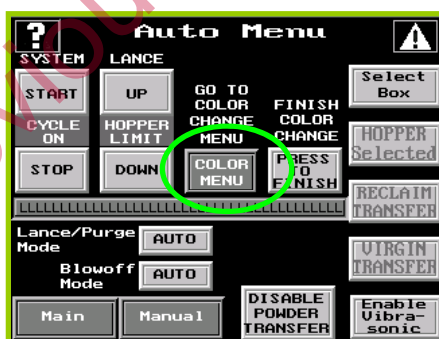

3

Color Change

Lance/Purge Mode

DISABLE SIEVE

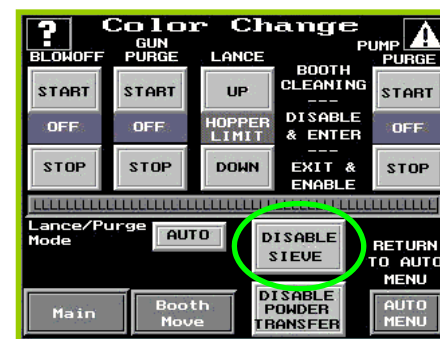

# Procedure 2

## OPERATOR B

1

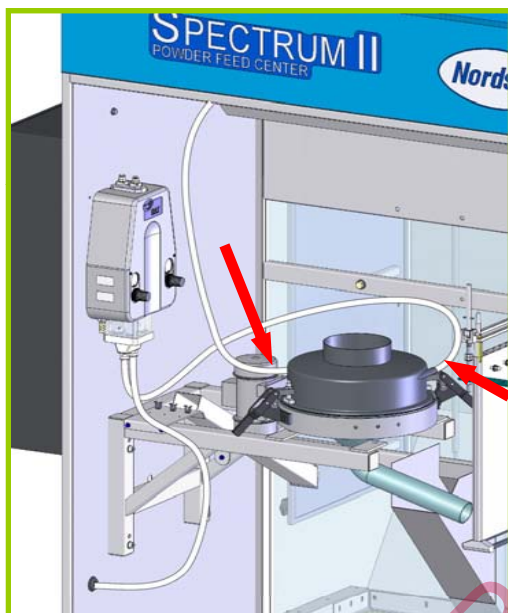

Disconnect the reclaim and bulk feed transfer hoses from the sieve deck. (Bulk feed pump and hose are optional.)

2



Place the ends of the transfer hose(s) into the purge duct.

3



Unclamp the sieve and turn the pan chute so that it dumps into the collector chute. Reclamp the sieve.

# Procedure 3

OPERATOR B

1

Color Change

Lance/Purge  
Mode

ENABLE  
SIEVE

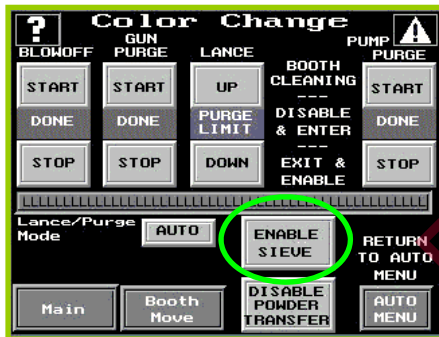

2

Color Change

BLOWOFF

START

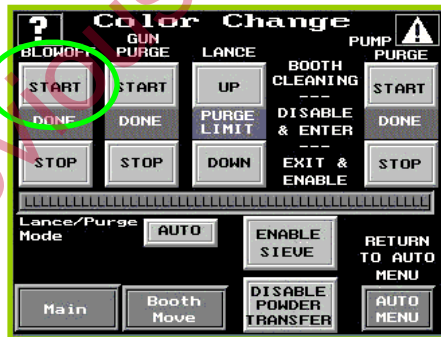

**NOTE:** When the gun blowoff starts the lance assembly automatically raises.

3

Color Change

Allow VIRGIN  
Pump Purge?

YES

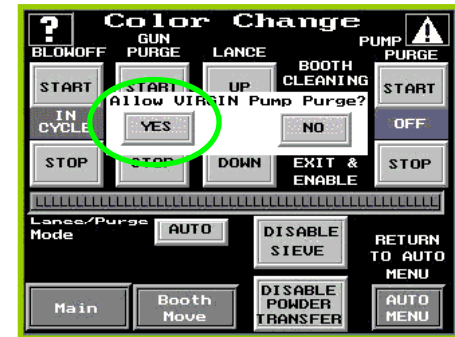

**NOTE:** Touching YES restarts the virgin powder pump so that it can be purged.

# Procedure 3

## OPERATOR B

4



Remove the powder source from the feed center.

**NOTE:** If using a fluidizing hopper, turn the fluidizing air off and disconnect the air tubing from the hopper.

5



Blow off the lance assembly.



**COLOR CHANGE  
CYCLE DONE**

Light flashes when gun  
blowoff is complete.

# Procedure 4

## OPERATOR B

1

Color Change

GUN PURGE

START



**NOTE:** The lance assembly automatically lowers onto the purge manifold.

2



**COLOR CHANGE  
CYCLE DONE**  
Light flashes when gun  
purge is complete.

**OPERATOR A:**  
Start cleaning the  
booth. Go to page 12.

**NOTE:** The lance assembly  
automatically raises when  
the gun purge is complete.

3



Blow off lances and  
feed center until  
clean.

# Procedure 5

## OPERATOR B

1



### For Hard-to-Clean Powders Only:

- Unclamp and remove the hose manifolds.
- Remove the gun pumps.
- Clean the lance tubes with a damp shop towel attached to a rod.
- Re-install the pumps and hose manifolds.

2



### Systems with Alternate Color Hose Sets:

Unclamp and remove the hose manifolds.

Blow out the pumps.

3



### Systems with Alternate Color Hose Sets:

Install the alternate hose manifold.

# Procedure 5

## OPERATOR B

4



### **Systems with Alternate Color Hose Sets:**

At the back of the spray guns, disconnect the powder feed hose from each spray gun and connect the alternate feed hose.

### **For Hard-to-Clean Powders Only:**

Disconnect the powder feed hose from the gun.

Remove the nozzle and electrode from the gun and blow them off.

Blow air through the gun tube from the front to back.

# Procedure 6

## OPERATOR B

1

Color Change

Lance/Purge  
Mode

DISABLE  
SIEVE

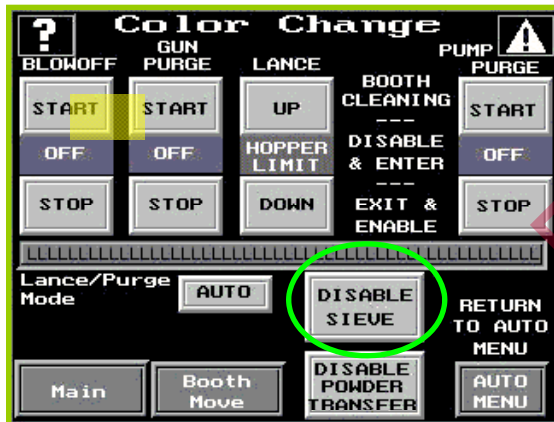

2



Unclamp and  
disassemble the  
sieve.

3



Blow off the  
deck, screen,  
and pan.

4

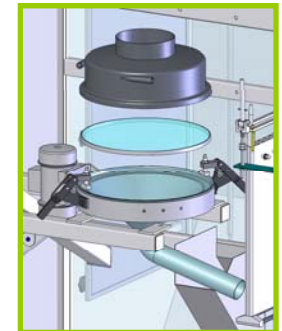

Assemble  
sieve with  
the pan  
chute  
toward the  
lances.

# Procedure 7

## OPERATOR A

1



Blow off door sills at entry end of the booth, then enter booth and blow off ceiling and walls.

2



Blow off AeroDecks™

3



Blow out inlet duct and vertical duct.

4



Set AeroDecks™ in operating position and exit booth.

**For Hard-to-Clean Powders:** Use damp cotton towels to wipe down the booth walls, sloped surfaces, floor, inlet duct, and vertical duct.

# Procedure 8

## OPERATOR A

1

Color Change

PUMP PURGE

START

x2

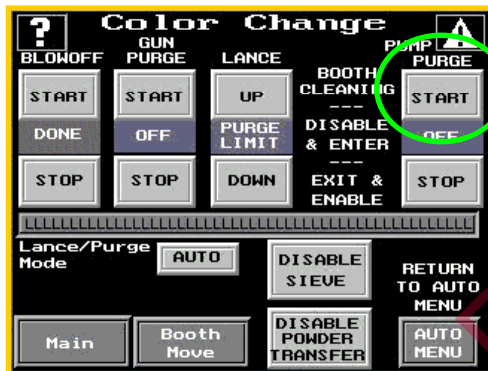

**NOTE:** Make sure all transfer hoses are parked in the feed center purge duct. Touch PUMP PURGE START twice to purge the reclaim and virgin HDLV pumps.

2



Open the transfer pan and blow out all powder remaining in pan.

3

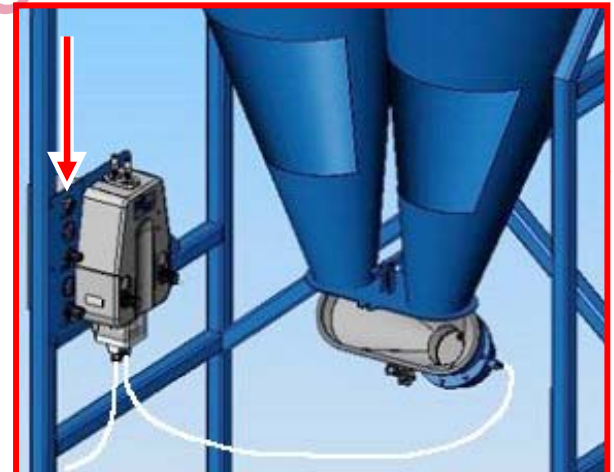

**NOTE:** If the automatic pump purge sequence completes before the pan is clean, **press and hold** the MANUAL PURGE button on the reclaim pump panel to finish cleaning the pan.

# Procedure 8

## OPERATOR A

4



Open the cyclone access doors and blow off the interior using the short wand, then the long wand.

**For Hard-to-Clean Powders Only:**  
With a damp cotton towel, wipe all surfaces inside the cyclone and transfer pan.

5



Close and latch the cyclone access doors.

# Procedure 8

## OPERATOR A

6



Close and latch the transfer pan.

7

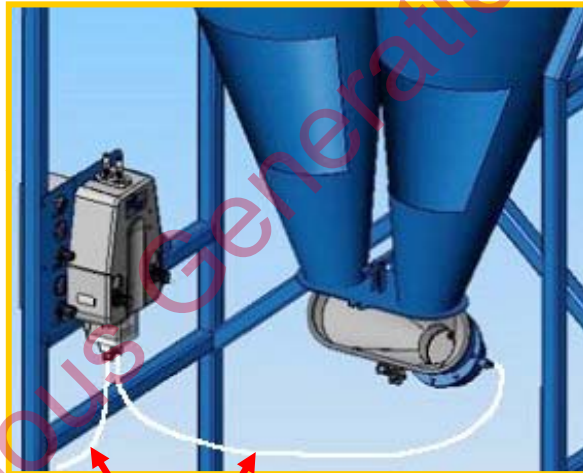

### **Systems with Alternate Color Hose Sets:**

Install an alternate hose between the pump inlet and the transfer pan.  
Connect the alternate hose to the reclaim pump outlet.

### **If Switching to Spray-to-Waste:**

Connect a transfer from the reclaim pump outlet to a waste container inlet.

# Procedure 9

OPERATOR B

1

Color Change

ENABLE  
SIEVE

2

Color Change

AUTO  
MENU

1

Auto Menu

PRESS  
TO  
FINISH

Auto Menu

ENABLE  
POWDER  
TRANSFER

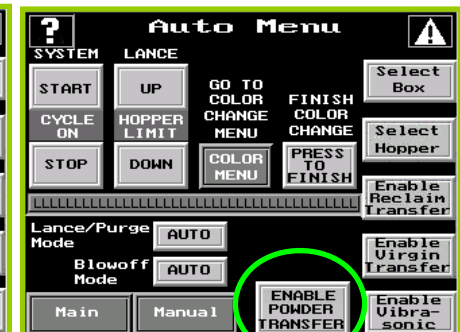
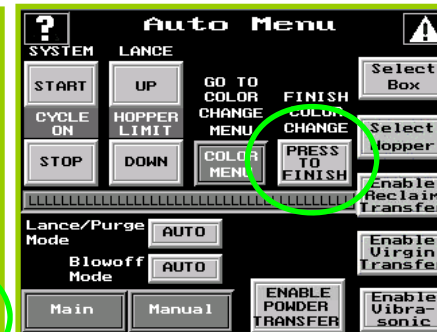
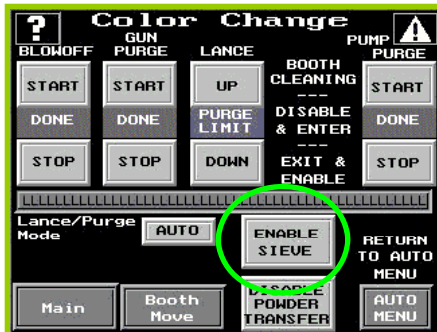

# Procedure 9

## OPERATOR B

### AUTO MENU SELECTIONS

Specify how the system will operate for this color run.

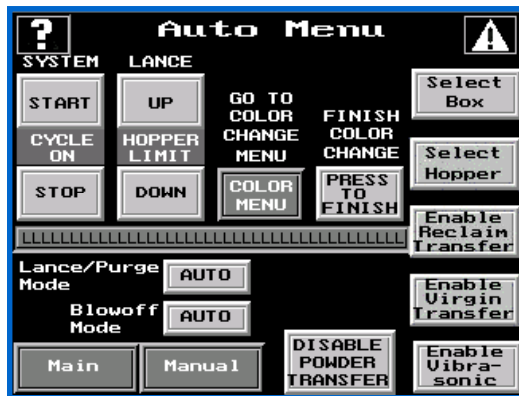

Select Box

or

Select Hopper

Starts fluidizing air and lowers lance assembly to appropriate level.

Enable Reclaim Transfer

**Spray-to-Reclaim:**

Select this button.

Oversprayed powder will be reclaimed.

**Spray-to-Waste:**

Do not select this button.

Oversprayed powder will be scrapped.

Enable Virgin Powder

Turns on HDLV bulk feed system.

Enable Vibra-sonic

Turns on Vibrasonic sieve screen.

**NOTE: Spray 0.5 kg (1 lb.) of powder to waste before performing Procedure 10. Amount of time required may vary.**

# Procedure 10

## OPERATOR B

### 1 Spray to Reclaim Systems:



Remove the reclaim and bulk feed transfer hoses from the purge duct. Connect the hoses to the sieve deck.

**Systems with Alternate Color Hose Sets:**  
Connect the alternate reclaim transfer hose to the cover in place of the previous color hose.

### 2



Install a new powder feed source and connect fluidizing air tubing.

# Cyclone Components

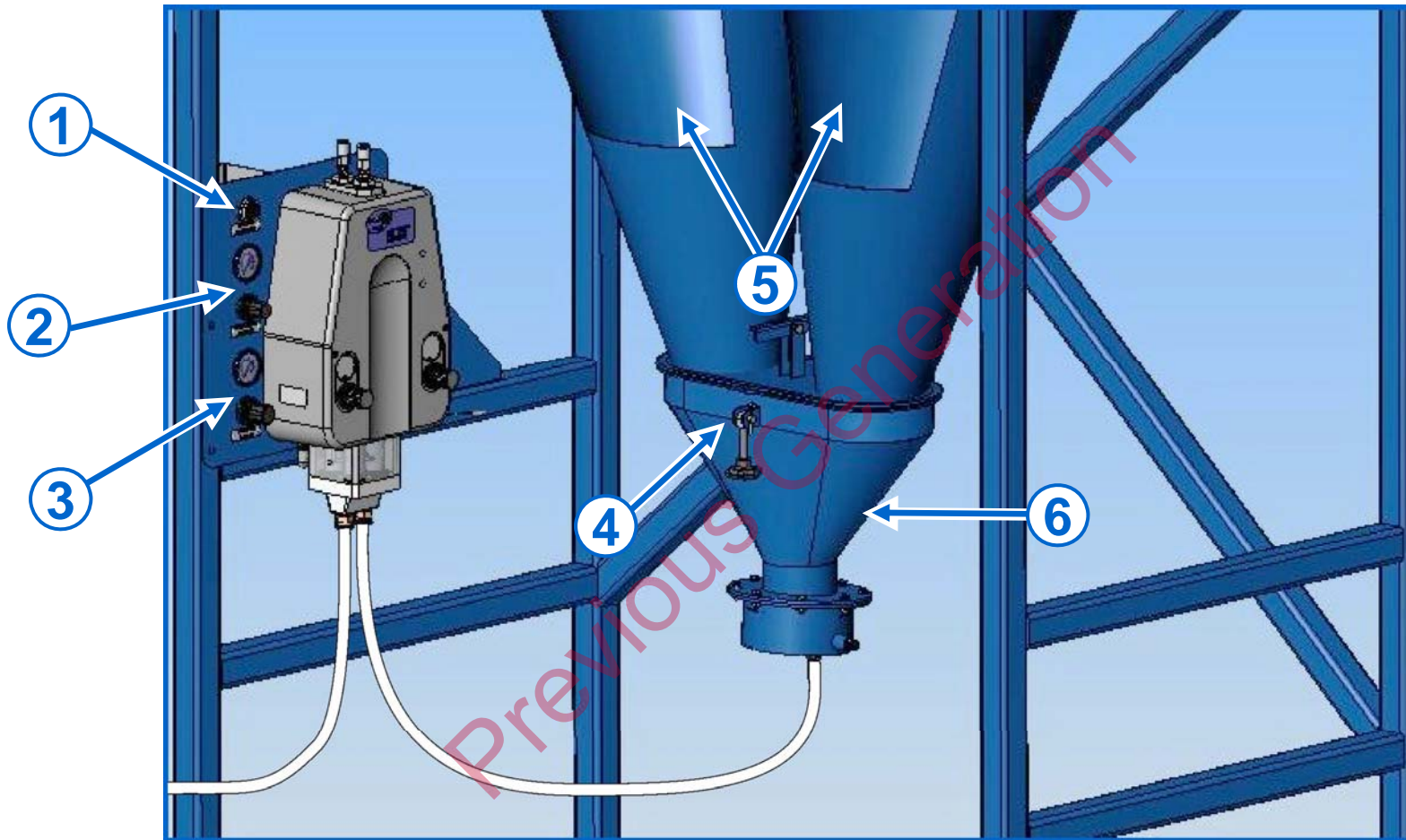

- 1. MANUAL PURGE button
- 2. Reclaim pump supply air regulator/gauge
- 3. Transfer pan fluidizing air regulator/gauge

- 4. Transfer pan latch
- 5. Cyclone access doors
- 6. Transfer pan

# Feed Center Components

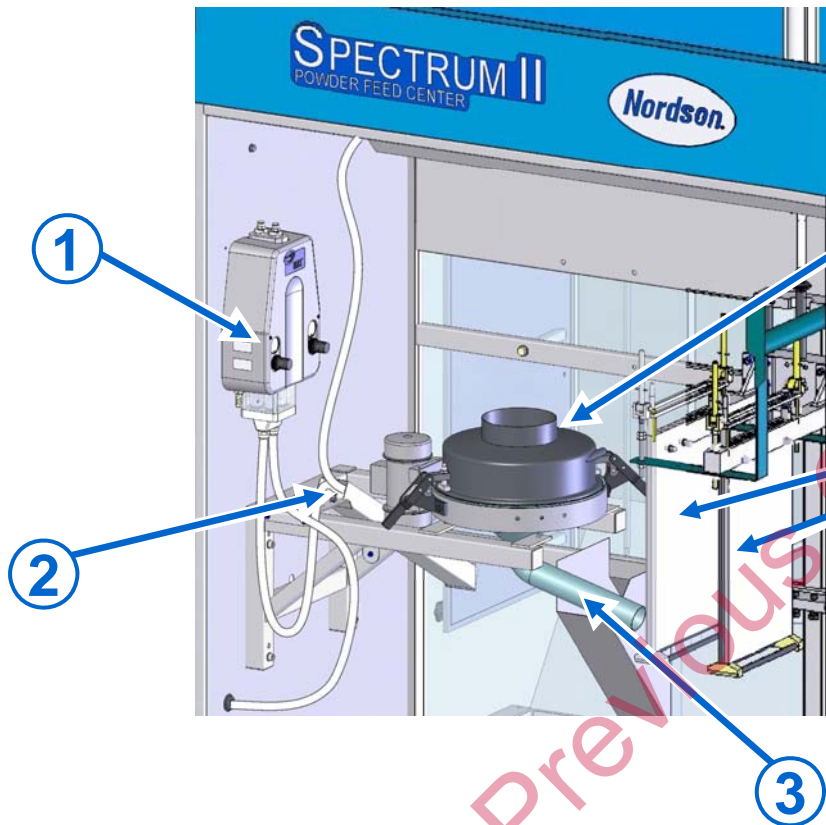

1. Bulk feed HDLV pump (optional)
2. Purge duct
3. Sieve Pan/Chute
4. Lance assemblies
5. Sieve deck (Sieve screen inside)



Nordson Corporation • 300 Nordson Drive • Amherst, Ohio 44001