

# Prodigy® Powder Port Feed Center

Customer Product Manual

Part 1056625\_08

Issued 09/14

**For parts and technical support, call the  
Finishing Customer Support Center at (800) 433-9319.**

This document is subject to change without notice.  
Check <http://emanuals.nordson.com> for the latest version.

---



# Table of Contents

<b>Safety</b> .....	<b>1</b>	Color Change Operation .....	23
Qualified Personnel .....	1	Transfer Pump Manual Purging .....	23
Intended Use .....	1	Startup .....	24
Regulations and Approvals .....	1	Normal Operation .....	25
Personal Safety .....	2	Emptying the Feed Center Collector Hopper .....	26
Fire Safety .....	2	Color Change Procedures .....	27
Grounding .....	3	Spray-to-Waste Procedure .....	27
Action in the Event of a Malfunction .....	3	Reclaim Procedure .....	28
Disposal .....	3	Completing a Color Change Cycle .....	29
<b>Description</b> .....	<b>4</b>	<b>Maintenance</b> .....	<b>30</b>
Components .....	5	Daily Maintenance .....	30
Reclaim and Virgin Powder Pump Connections .....	9	Periodic Maintenance .....	31
Feed Center Operator Panel Controls .....	10	HDLV Transfer Pump and	
Solenoid Panel Controls .....	11	Transfer Pan Maintenance .....	32
HDLV Reclaim Pump Panel Controls .....	12	Transfer Pan Cleaning .....	33
System Manuals .....	13	Disassembly .....	33
<b>Setup</b> .....	<b>13</b>	Cleaning .....	33
Feed Center PLC Settings .....	13	Assembly .....	33
Virgin Powder Transfer Delay .....	13	<b>Troubleshooting</b> .....	<b>35</b>
Low Powder Alarm Delay .....	13	Troubleshooting Chart .....	35
HDLV Transfer Pump Purge Pulse Cycle Rate .....	14	<b>Repair</b> .....	<b>43</b>
HDLV Transfer Pump Purge Duration .....	14	Cartridge Filter Replacement .....	43
Changing Function Values .....	14	Collector Fluidizing Plate Replacement .....	45
Feed Center Air Pressure Settings .....	15	<b>Parts</b> .....	<b>46</b>
Transfer Pump Air Pressure Settings .....	15	Sieve Parts .....	46
<b>Programming</b> .....	<b>16</b>	Miscellaneous Parts .....	47
One Button Level Sensor Probe Programming .....	16	Reclaim Pump Panel Parts .....	49
LED Functions .....	16	Transfer Pan Parts .....	50
Empty Adjustment .....	17	<b>Optional Vibrasonic Sieve Screen</b> .....	<b>51</b>
Full Adjustment .....	17	Vibrasonic System Components .....	51
Locking and Unlocking Adjustment .....	18	Installation .....	52
Operational Faults (Red LED Flashing) .....	18	Vibrasonic Transducer and	
Two Button Level Sensor Probe Programming .....	19	Sieve Screen Installation .....	52
LED Functions for Operation .....	19	Control Box and Cable Installation .....	52
Empty (no powder) Adjustment .....	20	Operation .....	52
Full Adjustment .....	20	Troubleshooting .....	53
Locking and Unlocking Adjustment .....	21	Fault Conditions .....	53
Operational Faults .....	21	Fault Causes and Corrective Actions .....	53
<b>Operation</b> .....	<b>22</b>	VIBRASONICS/POWER	
HDLV Transfer Pump and Sieving Operation .....	22	Indicator Troubleshooting .....	54
Sieve Operation .....	22	Vibrasonic System Parts .....	55
Transfer Pump Selector Switch Operation .....	22		
Reclaim Transfer Pump Operation .....	22		
Virgin Transfer Pump Operation .....	22		

## Contact Us

Nordson Corporation welcomes requests for information, comments, and inquiries about its products. General information about Nordson can be found on the Internet using the following address:  
<http://www.nordson.com>.

Address all correspondence to:

Nordson Corporation  
 Attn: Customer Service  
 555 Jackson Street  
 Amherst, OH 44001

## Notice

This is a Nordson Corporation publication which is protected by copyright. Original copyright date 2006. No part of this document may be photocopied, reproduced, or translated to another language without the prior written consent of Nordson Corporation. The information contained in this publication is subject to change without notice.

## Trademarks

HDLV, Prodigy, Nordson, and the Nordson logo are registered trademarks of Nordson Corporation.



Previous Generation

# Prodigy® Powder Port Feed Center

## Safety

Read and follow these safety instructions. Task- and equipment-specific warnings, cautions, and instructions are included in equipment documentation where appropriate.

Make sure all equipment documentation, including these instructions, is accessible to all persons operating or servicing equipment.

## Qualified Personnel

Equipment owners are responsible for making sure that Nordson equipment is installed, operated, and serviced by qualified personnel. Qualified personnel are those employees or contractors who are trained to safely perform their assigned tasks. They are familiar with all relevant safety rules and regulations and are physically capable of performing their assigned tasks.

## Intended Use

Use of Nordson equipment in ways other than those described in the documentation supplied with the equipment may result in injury to persons or damage to property.

Some examples of unintended use of equipment include

- using incompatible materials
- making unauthorized modifications
- removing or bypassing safety guards or interlocks
- using incompatible or damaged parts
- using unapproved auxiliary equipment
- operating equipment in excess of maximum ratings

## Regulations and Approvals

Make sure all equipment is rated and approved for the environment in which it is used. Any approvals obtained for Nordson equipment will be voided if instructions for installation, operation, and service are not followed.

All phases of equipment installation must comply with all federal, state, and local codes.

## **Personal Safety**

To prevent injury follow these instructions.

- Do not operate or service equipment unless you are qualified.
- Do not operate equipment unless safety guards, doors, or covers are intact and automatic interlocks are operating properly. Do not bypass or disarm any safety devices.
- Keep clear of moving equipment. Before adjusting or servicing any moving equipment, shut off the power supply and wait until the equipment comes to a complete stop. Lock out power and secure the equipment to prevent unexpected movement.
- Relieve (bleed off) hydraulic and pneumatic pressure before adjusting or servicing pressurized systems or components. Disconnect, lock out, and tag switches before servicing electrical equipment.
- Obtain and read Material Safety Data Sheets (MSDS) for all materials used. Follow the manufacturer's instructions for safe handling and use of materials, and use recommended personal protection devices.
- To prevent injury, be aware of less-obvious dangers in the workplace that often cannot be completely eliminated, such as hot surfaces, sharp edges, energized electrical circuits, and moving parts that cannot be enclosed or otherwise guarded for practical reasons.

## **Fire Safety**

To avoid a fire or explosion, follow these instructions.

- Do not smoke, weld, grind, or use open flames where flammable materials are being used or stored.
- Provide adequate ventilation to prevent dangerous concentrations of volatile materials or vapors. Refer to local codes or your material MSDS for guidance.
- Do not disconnect live electrical circuits while working with flammable materials. Shut off power at a disconnect switch first to prevent sparking.
- Know where emergency stop buttons, shutoff valves, and fire extinguishers are located. If a fire starts in a spray booth, immediately shut off the spray system and exhaust fans.
- Clean, maintain, test, and repair equipment according to the instructions in your equipment documentation.
- Use only replacement parts that are designed for use with original equipment. Contact your Nordson representative for parts information and advice.

## Grounding



**WARNING:** Operating faulty electrostatic equipment is hazardous and can cause electrocution, fire, or explosion. Make resistance checks part of your periodic maintenance program. If you receive even a slight electrical shock or notice static sparking or arcing, shut down all electrical or electrostatic equipment immediately. Do not restart the equipment until the problem has been identified and corrected.

Grounding inside and around the booth openings must comply with NFPA requirements for Class II Division 1 or 2 Hazardous Locations. Refer to NFPA 33, NFPA 70 (NEC articles 500, 502, and 516), and NFPA 77, latest conditions.

- All electrically conductive objects in the spray areas shall be electrically connected to ground with a resistance of not more than 1 megohm as measured with an instrument that applies at least 500 volts to the circuit being evaluated.
- Equipment to be grounded includes, but is not limited to, the floor of the spray area, operator platforms, hoppers, photoeye supports, and blow-off nozzles. Personnel working in the spray area must be grounded.
- There is a possible ignition potential from the charged human body. Personnel standing on a painted surface, such as an operator platform, or wearing non-conductive shoes, are not grounded. Personnel must wear shoes with conductive soles or use a ground strap to maintain a connection to ground when working with or around electrostatic equipment.
- Operators must maintain skin-to-handle contact between their hand and the gun handle to prevent shocks while operating manual electrostatic spray guns. If gloves must be worn, cut away the palm or fingers, wear electrically conductive gloves, or wear a grounding strap connected to the gun handle or other true earth ground.
- Shut off electrostatic power supplies and ground gun electrodes before making adjustments or cleaning powder spray guns.
- Connect all disconnected equipment, ground cables, and wires after servicing equipment.

## Action in the Event of a Malfunction

If a system or any equipment in a system malfunctions, shut off the system immediately and perform the following steps:

- Disconnect and lock out electrical power. Close pneumatic shutoff valves and relieve pressures.
- Identify the reason for the malfunction and correct it before restarting the equipment.

## Disposal

Dispose of equipment and materials used in operation and servicing according to local codes.

## Description

The Prodigy Powder Port is a powder feed center expressly designed for use in Prodigy Powder Coating Systems. It supplies powder to Prodigy Manual and Automatic Spray Guns and can be used with both spray-to-waste and reclaim systems.



Figure 1 Prodigy Powder Port

The feed center consists of an enclosure with an exhaust fan, cartridge filters, pulse valves, and collector to collect and retain powder.

**NOTE:** The European version of the feed center does not have an exhaust fan, cartridge filters, or final filters. Instead, the feed center is connected to the booth afterfilter ductwork. The afterfilter exhaust fan generates the air flow through the feed center and carries the waste powder to the afterfilter.

Each side of the enclosure houses one or two pump panels. Each pump panel can hold up to 8 Prodigy HDLV spray gun pumps, one per spray gun (minimum system size is 4 guns, maximum size is 32 guns).

The pump panels are hinged to the enclosure so they can be swung out to provide access to the pumps and the feed center control panel. The pump control manifolds and circuit boards are housed inside the panels.

The Prodigy automatic spray gun pumps are configured and controlled by the Prodigy iControl system. Manual spray gun pumps are configured and controlled by Prodigy Manual Gun Controllers. Powder is supplied to the gun pumps from one or two lances (16 suction tubes per lance) and a fluidized bed feed hopper with a capacity of 26.7 kg (50 lb) of powder.

Prodigy High-Capacity HDLV transfer pumps deliver reclaimed and virgin powder to the vibratory sieve. The screened powder falls into the feed hopper. Both pumps are supplied with operating and purge pilot air from the feed center solenoid valve assembly.

## Components

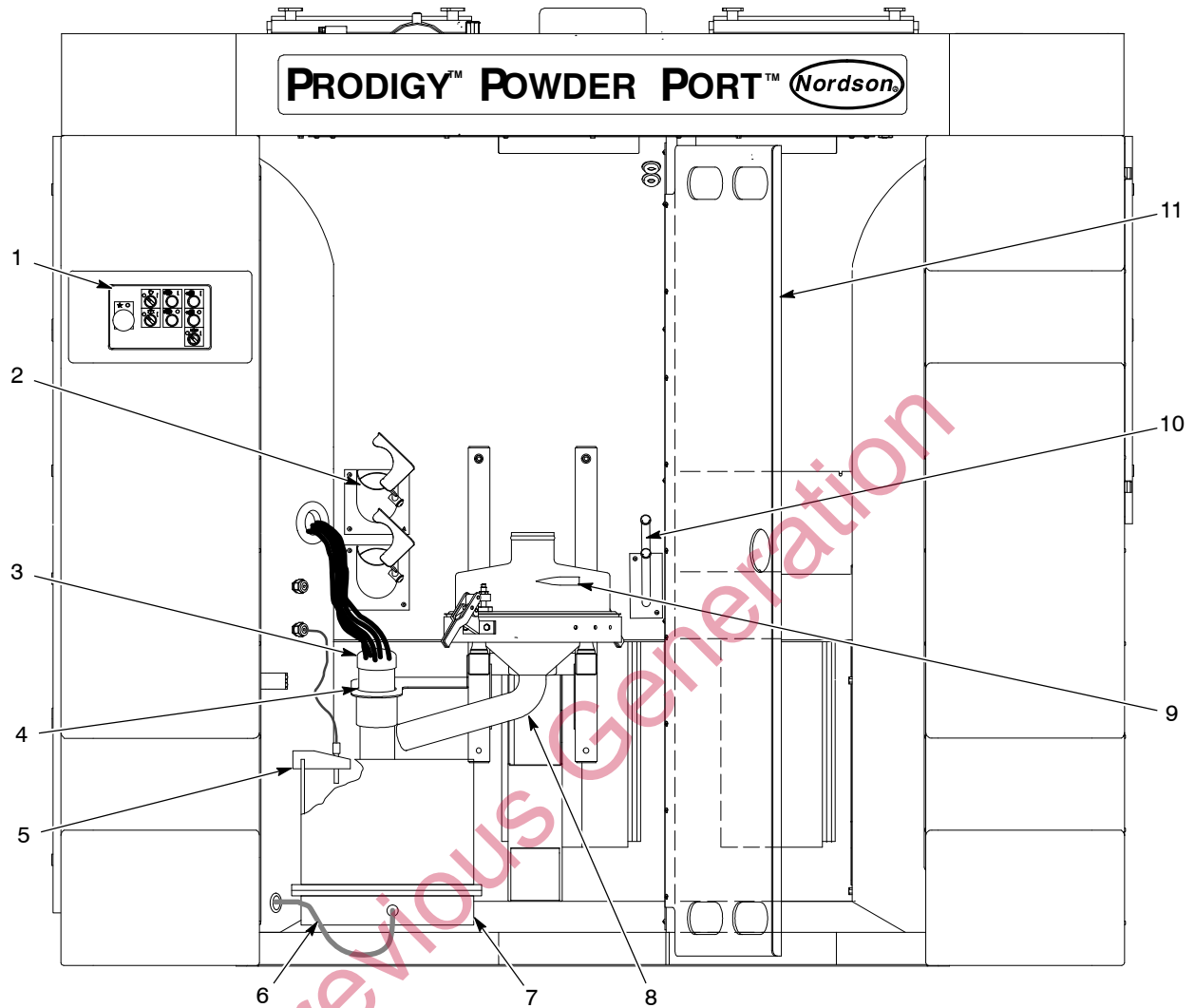

Figure 2 Front View of Feed Center

- |                       |                             |                                 |
|-----------------------|-----------------------------|---------------------------------|
| 1. Control panel      | 5. Level sensor and bracket | 9. Sieve deck inlets            |
| 2. Lance purge chutes | 6. Fluidizing air hose      | 10. Transfer tubing purge stubs |
| 3. Lances             | 7. Feed hopper              | 11. Clean zone door             |
| 4. Lance guides       | 8. Sieve discharge chute    |                                 |

**Components** (contd)

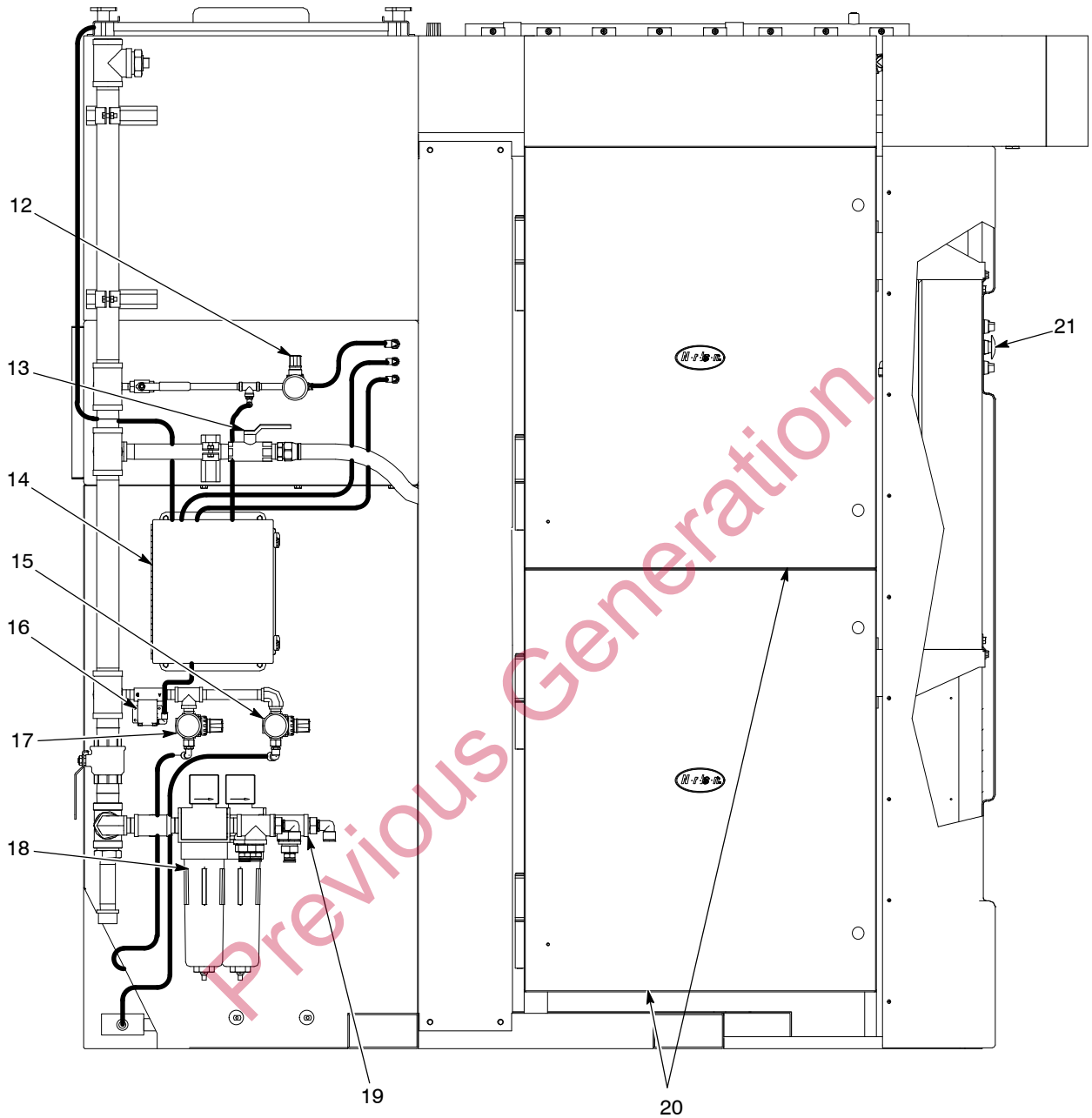

Figure 3 Left Side View of Feed Center (US version shown)

- |  |   |  |
|--|---|--|
| 12. Filter cartridge pulse air regulator | 16. Exhaust fan interlock valve               | 19. Filtered/unfiltered air supply for pump panels |
| 13. Accumulator tank air shutoff valve   | 17. Collector hopper fluidizing air regulator | 20. Pump panels                                    |
| 14. Solenoid panel                       | 18. Air filters                               | 21. Operator control panel                         |
| 15. Waste pump air regulator             |   |  |

Note: European version does not include items 11, 13–16.

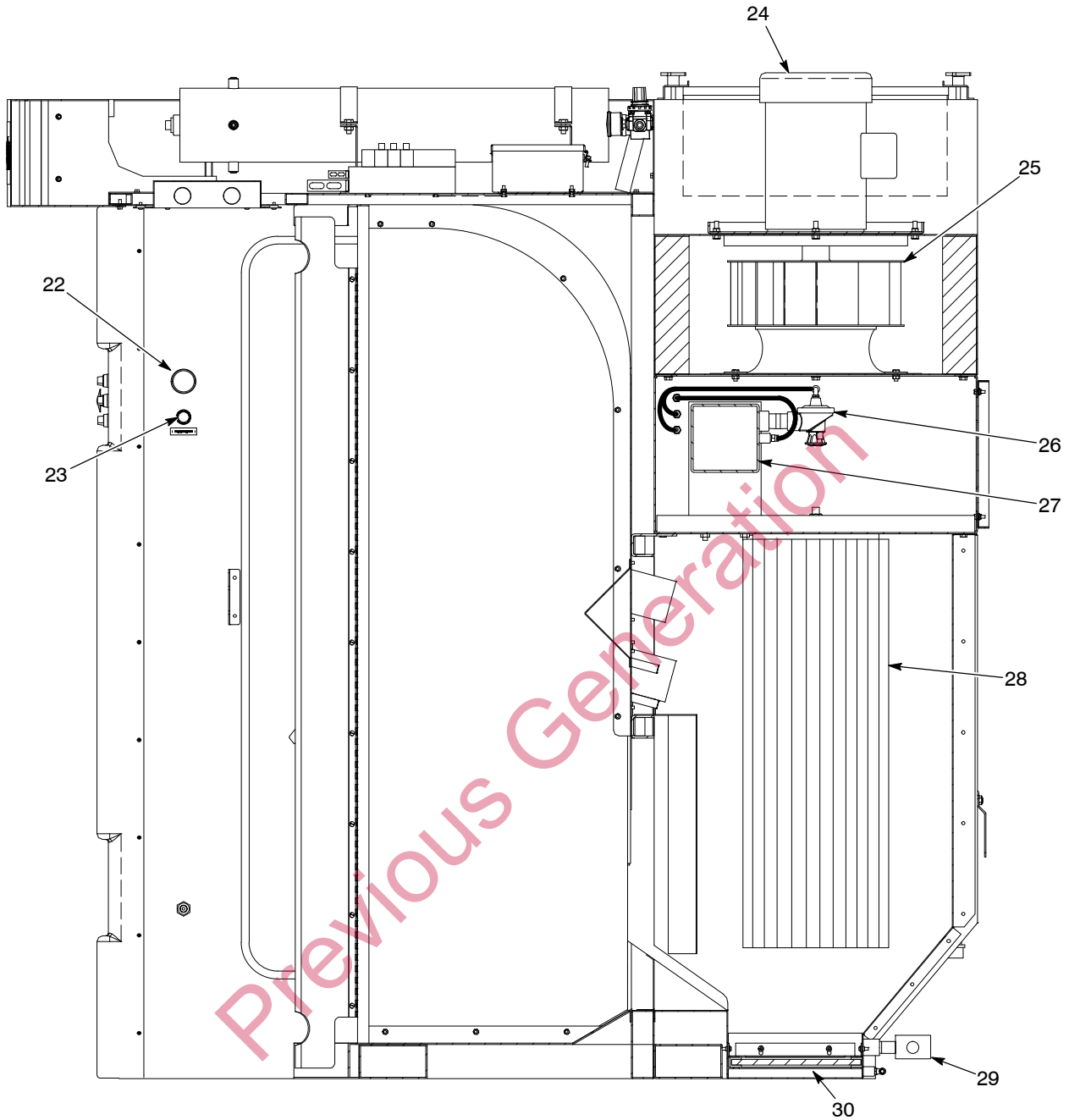

Figure 4 Cutaway View of Feed Center (US version shown)

- |  |                    |                       |
|--|--------------------|-----------------------|
| 22. Feed hopper fluidizing air gauge     | 25. Exhaust fan    | 28. Cartridge filters |
| 23. Feed hopper fluidizing air regulator | 26. Pulse valves   | 29. Waste pump        |
| 24. Exhaust fan motor                    | 27. Pulse manifold | 30. Fluidizing plate  |

Note: Cartridge filters are accessible through the side and rear access panels. European version does not include items 24-30.

**Components** (contd)

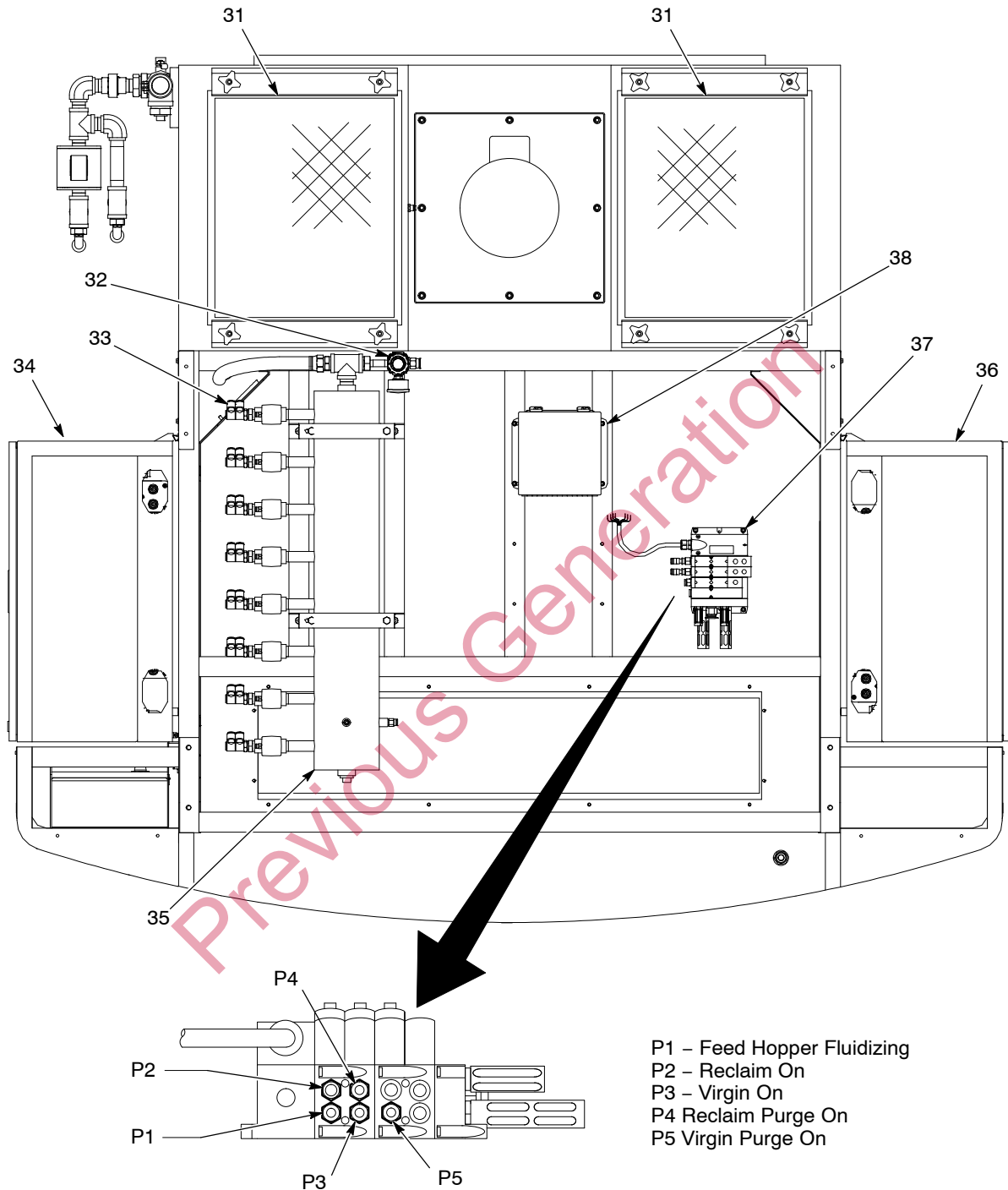

Figure 5 Top View of Feed Center (US version shown)

- |   |                                     |                             |
|---|-------------------------------------|-----------------------------|
| 31. Final filters                         | 34. Pump panels guns 1–16           | 37. Solenoid valve assembly |
| 32. Solenoid valve assembly air regulator | 35. Pump purge air accumulator tank | 38. Network interface box   |
| 33. HDLV pump purge air outlets           | 36. Pump panels guns 17–32          |                             |

*Note:* European version does not include item 31.

## Reclaim and Virgin Powder Pump Connections

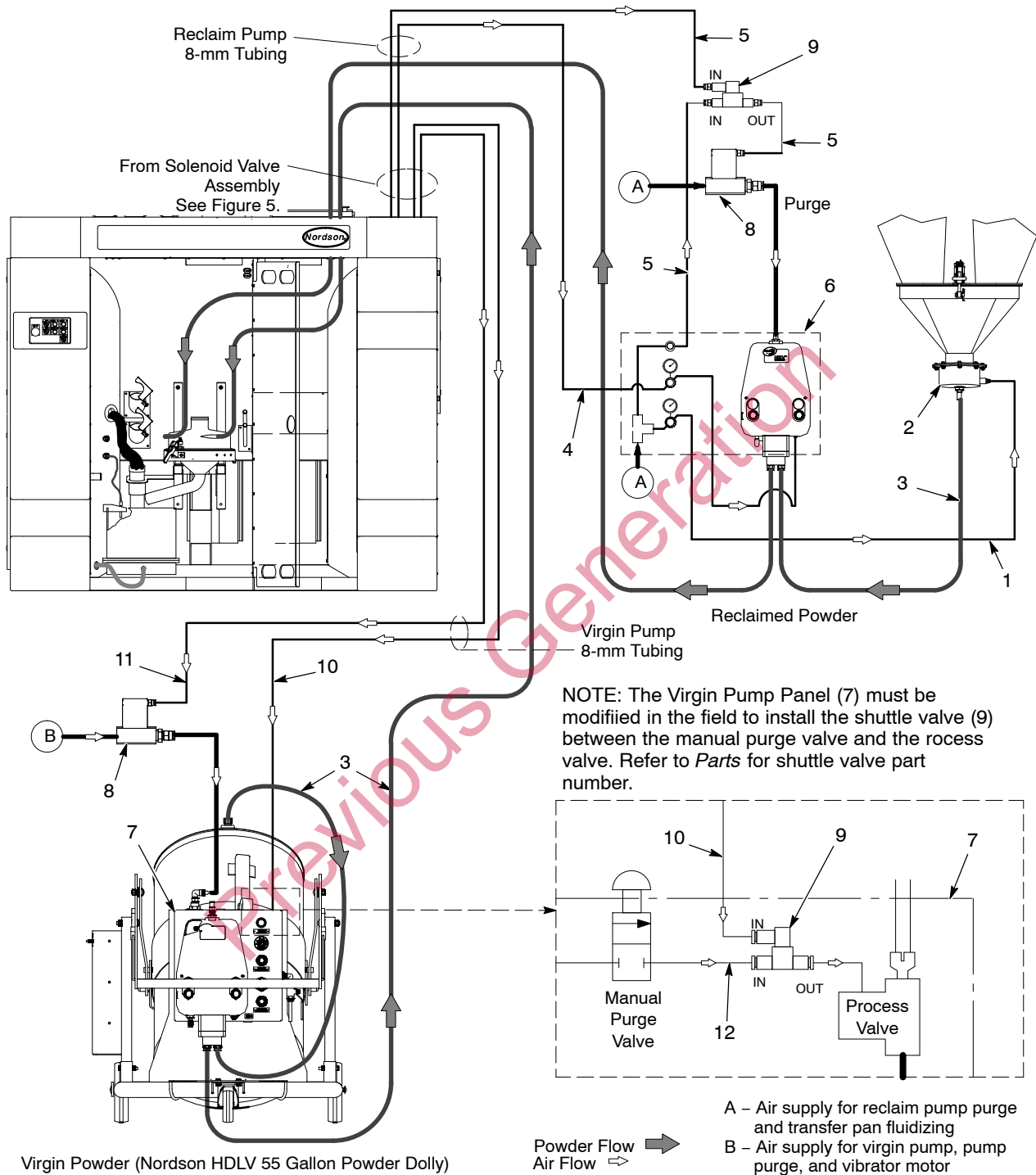

Figure 6 Optional Reclaim and Virgin Powder Connections and Equipment

- |                                |                                 |                                     |
|--------------------------------|---------------------------------|-------------------------------------|
| 1. Transfer pan fluidizing air | 5. Reclaim pump purge pilot air | 9. Shuttle valve                    |
| 2. Transfer pan                | 6. Reclaim pump panel           | 10. Virgin pump purge pilot air     |
| 3. 12 mm powder tubing         | 7. Virgin pump panel (see Note) | 11. Virgin pump operating pilot air |
| 4. Reclaim Pump operating air  | 8. Pilot-operated air valves    | 12. Manual purge pilot line         |

## Feed Center Operator Panel Controls

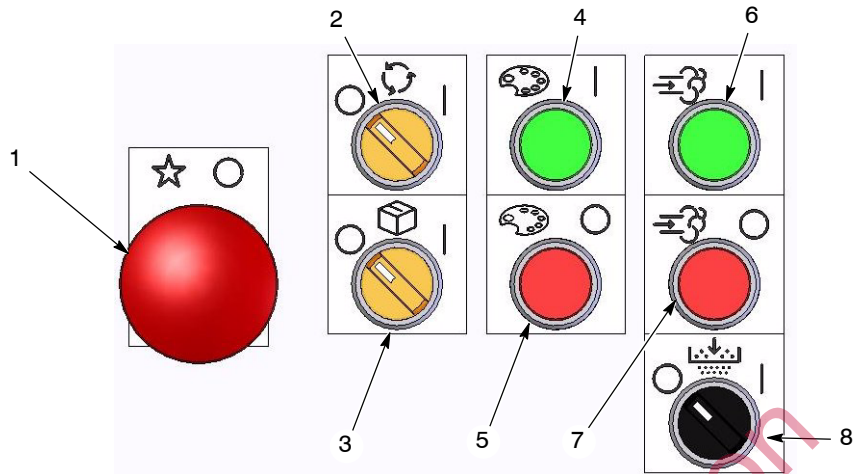

Figure 7 Feed Center Operator Control Panel

- |                        |                              |                             |
|------------------------|------------------------------|-----------------------------|
| 1. Emergency Stop      | 4. Color Change Start        | 7. Transfer Pump Purge Stop |
| 2. Reclaim Pump On/Off | 5. Color Change Stop         | 8. Sieve On/Off             |
| 3. Virgin Pump On/Off  | 6. Transfer Pump Purge Start |                             |

Control	Description
Emergency Stop	Shuts down the entire powder coating system. Rotate the button in the direction of the arrow to reset.
Reclaim Transfer Pump On/Off	Turns on and off the reclaim transfer pump. The pump runs continuously when turned on. Lights amber when pump is on.
Virgin Transfer Pump On/Off	Enables and disables the virgin transfer pump. Lights amber when pump is on. When enabled, the pump is controlled by the level sensor and a delay timer. The delay timer prevents the pump from starting until the delay runs out, to prevent pump chattering (rapid on/off cycles).
Color Change Start	Starts the color change process. Lights green when on. The spray guns, gun pumps, and lances are automatically purged and the guns are blown off.
Color Change Stop	Notifies system that all feed center color change tasks are complete. Stops process if pressed before complete. Silences low powder audible alarm.
Reclaim/Virgin Transfer Purge Start	Starts the reclaim and virgin transfer pump purge process. Lights green when on, flashes during purge cycle, off when complete. The purge cycle is controlled by the feed center controller programming. To abort the cycle press the Purge Stop button.  <b>NOTE:</b> As long as a color change cycle is not in progress the Reclaim and/or Virgin transfer pumps can be manually purged by pressing and holding the feed center Purge Start button. Purging continues as long as the button is pressed.
Reclaim/Virgin Transfer Purge Stop	Stops the reclaim and virgin transfer pump purge process.
Sieve On/Off	Starts and stops the vibratory sieve.

## Solenoid Panel Controls

**NOTE:** These controls are not used on the European version.

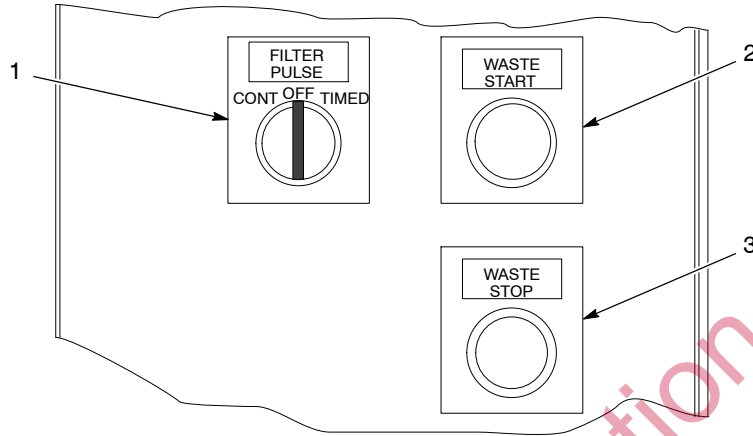

Figure 8 Solenoid Panel Controls (US version only)

1. Cartridge filter pulse mode                      2. Collector transfer pump start                      3. Collector transfer pump off

Control	Description
Cartridge Filter Pulse Mode Switch	<p>OFF: Cartridge filter pulsing stopped.</p> <p>CONT: Continuous. Filter pulsing runs continuously, controlled by delay and duration settings.</p> <p>TIMED: Filter pulsing controlled by timer settings. Filter is pulsed in long intervals.</p> <p>Settings are made on the Siemens Logo controller in the main system panel. Refer to the Operation section for instructions on changing settings.</p>
Waste Pump Start Button/Amber Indicator	<p>Turns on the fluidizing air for the feed center collector hopper and starts the transfer pump.</p> <p><b>NOTE:</b> Pump on time is controlled by a delay timer set on the Siemens Logo controller in the main system panel. The factory default setting is 10 minutes.</p>
Waste Pump Stop Button	<p>Overrides controller timer and turns off transfer pump and fluidizing air.</p>

## HDLV Reclaim Pump Panel Controls

The reclaim pump panel is typically mounted close to the recovery system cyclones. To maintain optimum powder delivery, keep the suction and delivery tubing no longer than:

Suction	3.65 m (12 ft)
Delivery	30.5 m (100 ft)

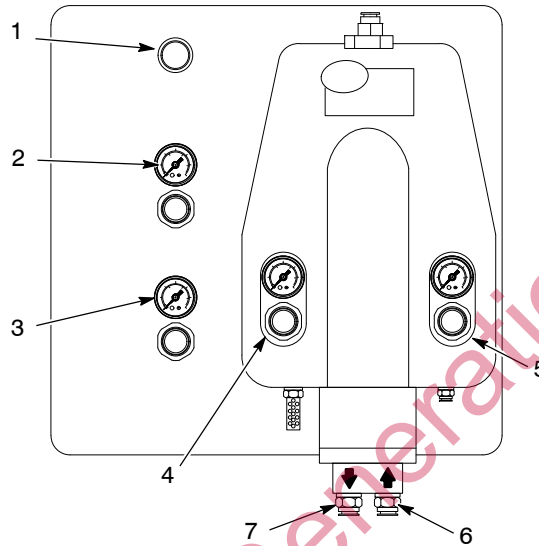

Figure 9 HDLV Reclaim Pump Panel (Typical)

- |                                |                     |
|--------------------------------|---------------------|
| 1. Manual purge                | 5. Pinch air (pump) |
| 2. Operating air               | 6. Suction port     |
| 3. Transfer pan fluidizing air | 7. Delivery port    |
| 4. Conveying air (pump)        |                     |

Control	Air Pressure Setting	Function
Manual Purge Button	→	Allows the operator to manually purge the suction and delivery tubing when not performing a color change.
Operating Air	4.8 bar ± 0.7 bar (70 psi ± 10 psi)	Regulates the incoming air to the reclaim transfer pump.
Transfer Pan Fluidize Air	0.14–0.2 bar (2–3 psi)	Regulates fluidizing air pressure to the transfer pan at the bottom of the cyclones.
Conveying Air	0.7–1.0 bar (10–15 psi)	Regulates the negative and positive air pressure that draws powder in and forces powder out of the pump.
Pinch Air	2.4–2.75 bar (35–40 psi)	Regulates the air pressure being applied to the pinch valves.

## System Manuals

Refer to the following manuals for more information on other system components:

Prodigy ColorMax Powder Coating System	1073883
Prodigy Automatic Spray Gun:	1054075
Prodigy Manual Spray Gun:	1077434
Prodigy iControl Operator Interface:	1056418
Prodigy iControl Console Hardware Manual:	1056419
iControl Operator Card:	1024758
Prodigy Manual Gun Controller:	1054580
Prodigy HDLV Pump Lance Assembly:	1070925
Prodigy HDLV Pump:	1081195
Prodigy HDLV Pump Panel:	1081748
High-Capacity HDLV Pump (Transfer):	1053991

Refer to the system diagram included with this manual for system components and connections.

Nordson product manuals are subject to change without notice. The latest versions can be downloaded from the Nordson emanuals web site at: <http://emanuals.nordson.com/finishing/>

## Setup

### Feed Center PLC Settings

The feed center functions are controlled by a PLC inside the feed center control panel. The following function values are programmed into the controller at the factory and can be adjusted as needed for the application.

#### Virgin Powder Transfer Delay

This delay timer starts when the powder level in the feed hopper falls below the level sensor, and the virgin transfer pump switch and sieve are ON. When the timer runs out, the virgin transfer pump is turned on. This delay prevents frequent pump starts and stops (chattering).

#### Low Powder Alarm Delay

If the virgin transfer pump switch is on and the powder level in the feed hopper falls below the level sensor, this delay timer starts. If no powder is detected before the timer runs out, the audible alarm is turned on. If powder is detected before the timer runs out, the timer is canceled.

### HDLV Transfer Pump Purge Pulse Cycle Rate

This timer sets the on/off cycle rate for the reclaim and virgin HDLV transfer pump purge sequence. The cycle is active while the pump purge duration timer is running.

### HDLV Transfer Pump Purge Duration

This timer sets the duration for the reclaim and virgin HDLV transfer pump purge sequence. The purge sequence stops when the duration timer runs out.

Table 1 Default Powder Transfer Setup Menu Settings

Designator	Function	Default Setting
B01:T	Virgin Powder Transfer Delay (sec)	40.00
B02:T	Low Powder Alarm Delay (min.)	3.00
B04:T	HDLV Pump Purge Pulse Cycle Rate (sec)	0.25
B05:T	HDLV Pump Purge Duration (sec)	30.00

### Changing Function Values

Swing aside the pump panels on the left side of the feed center to access the control panel. Open the panel door to access the PLC.

**NOTE:** These instructions are also reproduced on a label on the inside of the control panel door.



Figure 10 Feed Center PLC

1. Press the **ESC** and **OK** keys simultaneously.
2. Press the **DOWN** (▼) key until the display pointer is on **SET PARAM**.
3. Press the **OK** key. The display will show **Box:T** and register preset value.
4. Press the **UP** (▲) key or **DOWN** (▼) key to select the register preset value to change.
5. Press the **OK** key. The display will highlight the first digit of the preset value.
6. Press the **LEFT** (◀) or **RIGHT** (▶) key until the digit to change is highlighted.
7. Press the **UP** (▲) key or **DOWN** (▼) key to change the digit value.
8. After each digit is changed to the desired value, press the **OK** key.
9. To change another value, go back to step 4. To exit, press the **ESC** key twice to return to the **RUN** display.

### **Feed Center Air Pressure Settings**

<b>Air Pressure</b>	<b>Typical Setting</b>
Cartridge Filter Pulse Air	4.1 bar (60 psi)
Collector Transfer Pump*	2.75 bar (40 psi)
Collector Fluidizing*	0.5 bar (8 psi)
Solenoid Valve Air Supply	4.8 bar (70 psi)
* – You must press the Waste Start button to adjust these pressures.	

### **Transfer Pump Air Pressure Settings**

<b>Air Pressure</b>	<b>Typical Setting</b>
Operating Air	4.8 bar ± 0.7 bar (70 psi ±10 psi)
Transfer Pan Fluidize Air	0.14–0.2 bar (2–3 psi)
Conveying Air	0.7–1.0 bar (10–15 psi)
Pinch Air	2.4–2.75 bar (35–40 psi)

## Level Sensor Programming

The level sensor probe signals the feed center PLC to indicate that the level in the powder feed source is low. Follow these procedures to program the level sensor probe to recognize the level of powder in the feed source.

There are two different kinds of sensor probes that are identified by the number of programming buttons on the probe.

### One Button Level Sensor Probe Programming

When you program the level sensor probe, the powder feed center exhaust fan must be on and the powder in the hopper must be thoroughly fluidized.

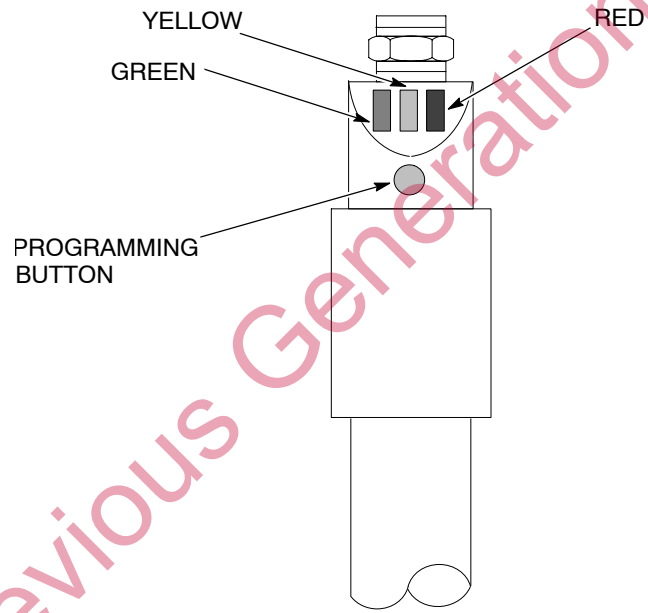

Figure 11 Programming the One Button Level Sensor Probe

### LED Functions

LED Color	Status	Meaning
Green	Lit continuously	Ready for operation (power is on)
Yellow	Lit continuously	Output has switched (powder is detected; full condition)
Yellow and Red	Flashing quickly	Short circuit of the switching output
Red	Lit temporarily	Normal function check; level sensor probe is approaching the full state
	Lit continuously	Level sensor probe is dirty or out of adjustment.

## Empty (no powder) Adjustment

**NOTE:** Completing the *Empty Adjustment* overwrites the values set in the *Full Adjustment*. If you complete an *Empty Adjustment*, be sure to complete a *Full Adjustment*.

1. Move the level sensor probe into the hopper until the powder covers at least 25 mm (1 in.) of the tip of the level sensor probe.
2. Remove the level sensor from the powder so that the bottom of the level sensor is at least 25 mm (1 in.) away from the top level of the powder.
3. See Figure 11. Press the programming button until the green LED flashes slowly. When the green LED stops flashing and the yellow LED turns off, the Empty Adjustment is complete.

**NOTE:** If the programming button remains pressed after the green LED flashes slowly, the green light will eventually start to flash quickly, signaling the programming for the Full Adjustment instead of the Empty Adjustment. To correct the error in programming, repeat the steps from the beginning for programming the Empty Adjustment.

## Full Adjustment

**NOTE:** You may complete the *Full Adjustment* as often as you like without overwriting the *Empty Adjustment* value.

1. Move the level sensor probe into the hopper until the powder covers at least 25 mm (1 in.) of the tip of the level sensor probe.
2. See Figure 11. Press the programming button until the green LED flashes quickly.

The green LED flashes slowly at first, then after five seconds it flashes quickly. When both the green and yellow LEDs are lit continuously, the full adjustment is complete.

## Locking and Unlocking Adjustment

The level sensor probe can be locked to protect it from unauthorized adjustment. Use these guidelines to lock or unlock the level sensor probe.

**NOTE:** The level sensor probe is shipped from the factory in the unlocked state.

Task	Procedure
<b>Locking</b>	Press the programming button for 10 seconds. The green LED will flash slowly for five seconds, then it will flash quickly. When the green LED turns off, the level sensor probe is locked. When the green LED turns back on continuously, the level sensor probe is ready for operation.
<b>Unlocking</b>	Press the programming button for 10 seconds. After 10 seconds, all LEDs turn off, indicating that the level sensor probe is unlocked.

## Operational Faults (Red LED Flashing)

If either the empty or full adjustment cannot be completed, the probe's red LED flashes quickly.

Task	Procedure
<b>Clearing a Fault</b>	Clear the fault by either: <ul style="list-style-type: none"> <li>pressing the programming button once, or</li> <li>turning off power to the feed center, then turning it back on again.</li> </ul>
<b>Correcting Possible Causes for the Fault</b>	Check for and correct any of these possible causes for the fault: <ul style="list-style-type: none"> <li>The difference between the empty and full states is not great enough.</li> <li>The empty adjustment was completed while the level sensor probe was in the powder, or the full adjustment was completed while the level sensor probe was out of the powder.</li> <li>During the empty adjustment, the distance between the level sensor probe and the powder was too short.</li> </ul>

## Two Button Level Sensor Probe Programming

When you program the level sensor probe, the powder feed center exhaust fan must be on and the powder in the hopper must be thoroughly fluidized.

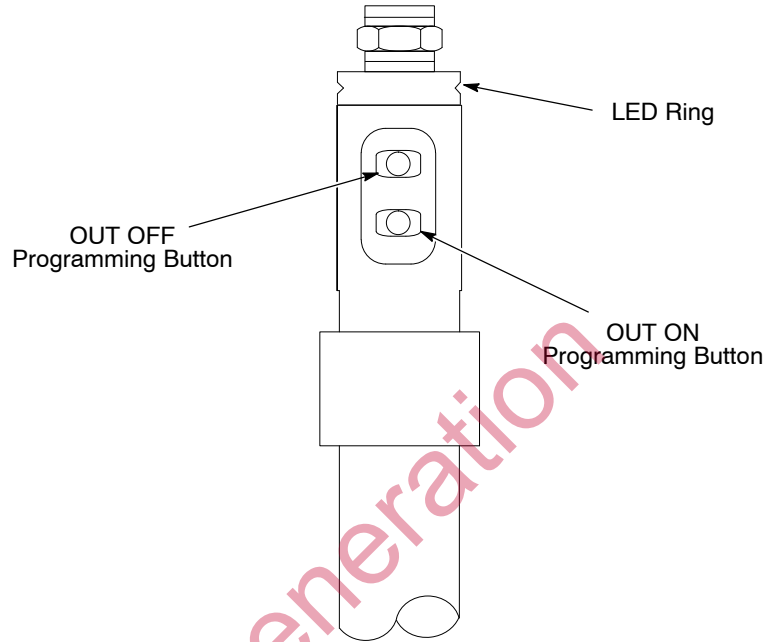

Figure 12 Programming the Two Button Level Sensor Probe

### LED Functions for Operation

LED Color	Status	Meaning
Green	On	Material not detected
Yellow	On	Material detected

### **Empty (no powder) Adjustment**

1. Move the level sensor probe into the hopper until the powder covers at least 25 mm (1 in.) of the tip of the level sensor probe.
2. Remove the level sensor from the powder so that the bottom of the level sensor is at least 25 mm (1 in.) away from the top level of the powder.
3. See Figure 12. Press the OUT OFF programming button until the LED ring slowly flashes yellow.
4. Release the button and the yellow light will go off. The empty adjustment is complete.

### **Full Adjustment**

1. Move the level sensor probe into the hopper until the powder covers at least 25 mm (1 in.) of the tip of the level sensor probe.
2. See Figure 12. Press the OUT ON programming button until the yellow light from the LED ring goes from flashing slowly to flashing quickly.
3. Release the button and the LED ring lights yellow continuously. The full adjustment is complete.

Previous Generation

## Locking and Unlocking Adjustment

The level sensor probe can be locked to protect it from unauthorized adjustment. Use these guidelines to lock or unlock the level sensor probe.

**NOTE:** The level sensor probe is shipped from the factory in the unlocked state.

Task	Procedure
<b>Locking</b>	Simultaneously press the two programming buttons for at 10 seconds in the operating mode. Once the LED ring light changes its status for a brief moment, release the buttons, and the lock is complete.
<b>Unlocking</b>	Simultaneously press the two programming buttons for at 10 seconds in the operating mode. Once the LED ring light changes its status for a brief moment, release the buttons, and the unlock is complete.

## Operational Faults

If the sensor deviates from normal operation, use the following steps to return to normal operation.

Task	Procedure
<b>Return to Normal Operation</b>	<p>Check for and correct any of these possible causes for incorrect operation:</p> <ul style="list-style-type: none"> <li>• The difference between the empty and full states is not great enough.</li> <li>• The empty adjustment was completed while the level sensor probe was in the powder, or the full adjustment was completed while the level sensor probe was out of the powder.</li> <li>• During the empty adjustment, the distance between the level sensor probe and the powder was too short.</li> </ul>

## Operation



**WARNING:** Allow only qualified personnel to perform the following tasks. Follow the safety instructions in this document and all other related documentation.

### ***HDLV Transfer Pump and Sieving Operation***

See Figure 7 for the feed center operator controls.

#### **Sieve Operation**

Powder is supplied to the feed center by the reclaim and virgin powder transfer pumps. The powder must pass through the vibratory sieve before filling the feed hopper.

The sieve is turned on and off with the Sieve selector switch. When the switch is off, the reclaim and virgin powder transfer pumps are disabled.

#### **Transfer Pump Selector Switch Operation**

Two selector switches control the operation of the Reclaim and Virgin powder transfer pumps. Each switch includes an amber indicator that lights when the transfer pump is turned on. Turning the switch to ON (I) enables the transfer pump.

If the reclaim or virgin transfer pump selector switches are in the ON position when the feed center is turned on, or after a color change cycle is completed, then the pumps will be forced off. To re-enable the pumps you must turn the selector switches off then on again.

The transfer pumps will not turn on if the sieve is not turned on.

#### **Reclaim Transfer Pump Operation**

When the reclaim transfer pump is turned on, solenoid 2 in the solenoid valve assembly on top of the feed center sends operating air to the transfer pump. The pump runs continuously to pump the reclaimed powder in the transfer pan back to the feed center.

#### **Virgin Transfer Pump Operation**

The feed hopper level sensor controls the virgin powder transfer pump operation. If the powder level falls below the level sensor a delay timer is started. When the delay timer runs out the solenoid 3 in the solenoid valve assembly on top of the feed center sends air to the virgin powder transfer pump. The pump runs until the powder in the feed hopper reaches the level sensor, then turns off.

If the virgin transfer pump remains on for too long a buzzer is turned on to warn the operator that the feed hopper powder supply has not been replenished.

The warning buzzer can be silenced by:

- filling the feed hopper until the powder supply contacts the level sensor
- pressing the color change stop button
- turning the virgin transfer pump switch to OFF

## ***Color Change Operation***

See Figure 7 for feed center operator panel controls.

A color change sequence is started by pressing the Color Change Start button. The sequence is finished or aborted by pressing the Color Change Stop button.

Pressing the Color Change Start button starts the spray gun purge and blowoff cycles. If turned on, the reclaim transfer pump will remain on to return reclaimed powder to the feed hopper. If turned on, the virgin transfer pump will be shut off.

When the spray gun purge and blowoff cycles are complete, the transfer pumps can be purged.

Turn the Reclaim and Virgin Transfer Pump selector switches to the ON position (if not on), then press and release the Purge Start button. The cycle control turns on the purge output and pulses the pump purge air for a set duration. During the purge cycle the pump selector switches will be lit and the green purge indicator light will flash. Pressing the Purge Stop button will abort the purge cycle.

When the purge cycle is complete, the transfer pumps are forced off. To turn them back on you must turn the pump selector switches to OFF and then to ON.

The automatic portion of the color change procedure is complete. Clean the booth, transfer pan, and feed center according to the instructions in the Color Change Procedure on page 27.

Press the Color Change Stop button to finish the color change cycle.

## ***Transfer Pump Manual Purging***

During a color change operation, the operator presses and releases the Purge Start button and the pumps are purged according to the programmed values in the feed center PLC.

During normal operations, if the transfer pumps become blocked, the operator can purge them manually by pressing and holding the Purge Start button (pump selector switches must be in ON position). The pumps will be purged as long as the Purge Start button is held down.

## Startup

1. If the feed center is not powered, swing open the top left pump panel and to access the control panel power switch and turn on power.
2. At the booth control panel, press the Feed Center Fan Start button.
3. Fill the feed hopper with 50 lbs of powder. If you have a bulk feed system you can use it to fill the hopper after placing it in the feed center.
4. See Figure 13. Position the feed hopper (4) under the lance guide (2).
5. Make sure the sieve discharge chute (5) is positioned so the screened powder will fall into the feed hopper. To position the chute, release the sieve deck clamps, rotate the chute, then retighten the clamps.
6. Connect the fluidizing air hose (3) to the hopper fluidizing pan.
7. Install the level sensor on the hopper. The slot in the sensor bracket slides over the edge of the hopper.
8. If used, connect the reclaim and virgin powder transfer tubing (7) to the sieve deck inlet stubs.

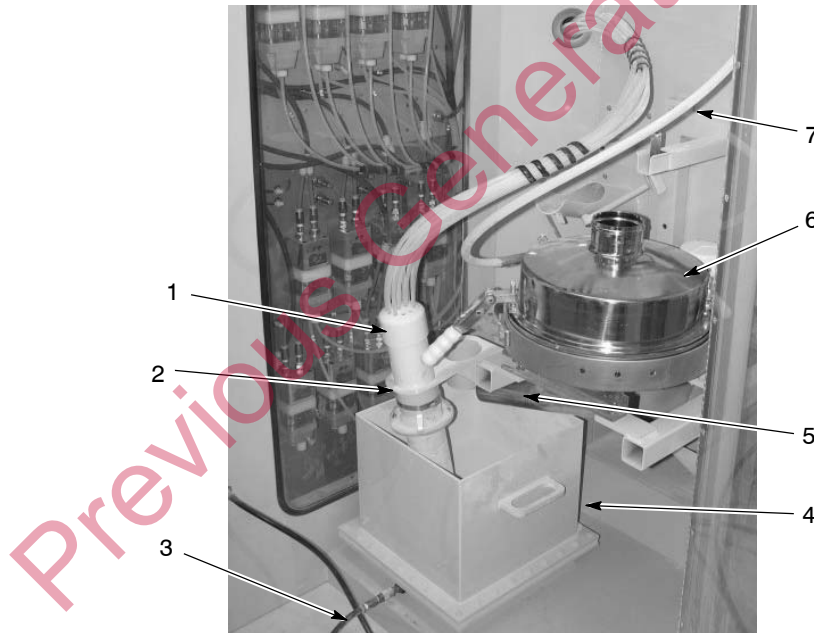

Figure 13 Feed Hopper and Sieve Setup and Connections

- |                        |                        |
|------------------------|------------------------|
| 1. Lance               | 5. Discharge chute/pan |
| 2. Lance guide         | 6. Sieve deck          |
| 3. Fluidizing air hose | 7. Transfer tubing     |
| 4. Feed hopper         |                        |

9. See Figure 14. Connect the feed center waste pump hose to the waste container lid. Make sure the waste container vent hose is connected to the vent stub mounted on the side of the feed center.

10. See Figure 7. Turn the Sieve switch to ON.
11. Turn the Virgin switch to ON if your system includes a bulk feed system. If the powder level in the feed hopper is below the level sensor, the system will turn on the virgin transfer pump after a short delay.
12. See Figure 4. Use the regulator on the left wall to adjust the feed hopper fluidizing air pressure so the powder is gently boiling.
13. See Figure 8. On the feed center solenoid panel, select Continuous or Timed filter pulsing.
14. See Figure 13. Install the lance(s) in the lance guide.
15. See Figure 6. If reclaiming powder, adjust the transfer pan fluidizing air regulator (typically on the reclaim pump control panel) to 0.14–0.2 bar (2–3 psi).
16. Turn the Reclaim switch to ON if reclaiming powder. The reclaim pump will start and run continuously.

The feed center is now ready for normal operation.

## ***Normal Operation***

**Powder Supply:** If the powder in the feed hopper falls below the level sensor and the virgin transfer switch and sieve are on, the virgin transfer pump will turn on after a short delay. A low powder alarm delay starts when the pump turns on. If the level sensor does not detect powder before the low powder alarm delay runs out, an audible alarm will sound.

**Final Filter Monitor:** If the final filters start to clog, a pressure monitor will detect the buildup of powder on the final filters and shut down the feed center fan. The shutdown is triggered by the pressure sensor in the solenoid panel, which is set to 3 in. w.c.

**Reclaim and Virgin HDLV Pump Manual Purge:** If the pump switches are on, the pumps can be manually purged by pressing and holding the Purge Start button. The pumps will be purged as long as the button is held down. The pump panels also include manual purge buttons, which allow the operator to purge the pumps at any time.

**Gun Control:** The automatic spray gun pumps are controlled by the iControl system. If manual spray guns are included in the system, they are controlled by Prodigy Manual Gun Controllers. Refer to the appropriate manuals for configuration and operation instructions.

**Color Change Procedures:** Refer to Color Change Procedures in this manual.

## Emptying the Feed Center Collector Hopper

The level of powder in the collector hopper should be visually monitored and pumped into a waste container as needed. To empty the hopper:

1. Turn on the feed center exhaust fan. It must be running or the interlock valve will not open to supply air to the pump and fluidizing pan.
2. See Figure 14. Install a waste lid on an empty 55 gallon drum.
3. Connect the waste lid ground wire to the feed center base or to another grounded structure such as the cyclone stand or booth base.
4. Connect a vent hose to the waste lid and the feed center vent stub on the filter access panel.
5. Connect the waste pump hose to the inlet stub on the waste lid.
6. Press the Waste Pump Start button on the feed center solenoid panel. When the collector hopper is empty, press the Waste Pump Stop button.

**NOTE:** The waste pump will stop automatically after an adjustable time delay. The factory default is 10 minutes.

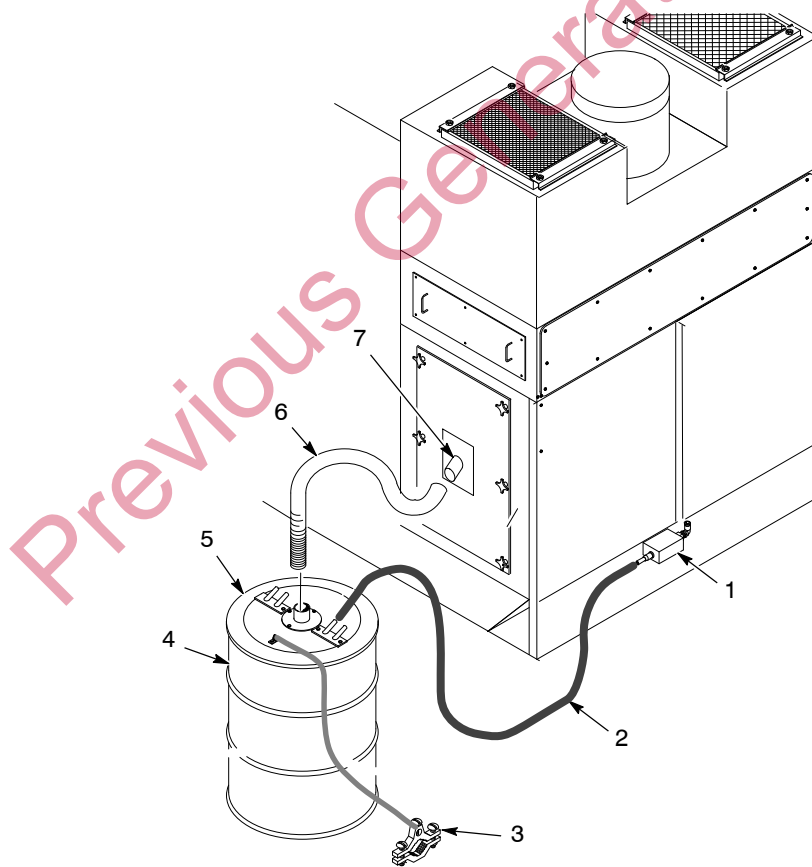

Figure 14 Waste Container Connections

- |                                     |              |
|-------------------------------------|--------------|
| 1. Waste pump                       | 5. Waste lid |
| 2. Powder transfer hose             | 6. Vent hose |
| 3. Waste lid ground cable and clamp | 7. Vent stub |
| 4. Waste drum                       |              |

## Color Change Procedures

### Spray-to-Waste Procedure

Use this procedure when spraying to waste. The powder collected in the cyclone transfer pan is pumped by the reclaim pump directly into a waste drum that is vented into the feed center collector or the booth.

1. If using a bulk feed system, turn OFF the virgin transfer pump switch.
2. Remove the level sensor and bracket from the feed hopper. Disconnect the fluidizing hose from the hopper.
3. Remove the lances from the lance guide and install them in the purge chutes. Rotate the locks in place over the lance ends.
4. Turn OFF the sieve switch.
5. If using a bulk feed system, disconnect the virgin transfer hose from the sieve deck and connect it to the waste stub on the back wall.
6. Make sure the manual gun operators have their spray guns pointed into the booth, or place the guns in holders that point into the booth.
7. Press the Color Change Start button to start the gun and pump purge/blowoff cycle.
8. While the gun/pump purge/blowoff cycle is running, move the feed hopper out of the feed center. Install the lid on the feed hopper before storing it.
9. Start cleaning the booth.
10. If using a bulk feed system:
  - a. Disconnect the suction tubing from the pickup tube. Connect the tubing to a powder collection system, which could be either the feed center or the afterfilter.
  - b. Turn ON the virgin transfer pump switch. The pump will turn on when the purge cycle is activated.
11. Press the Purge Start button to purge the transfer pump(s) and tubing. Purging will stop automatically at the end of the purge cycle. To abort the purge cycle press the Purge Stop button.
12. Blow off the sieve, then unclamp the sieve deck and blow it clean.
13. Remove the sieve screen. Clean the screen and gasket.
14. Blow off the sieve discharge pan.
15. Remove the lances from the purge chutes. Blow off the lances and purge chutes.
16. Blow off the lance guides and all inside surfaces of the feed center.
17. If using a bulk feed system, clean it as directed in its manuals.
18. Perform the Completing a Color Change Cycle procedure.

## Reclaim Procedure

Use this procedure when reclaiming oversprayed powder for reuse. The powder collected in the cyclone transfer pan is pumped by the reclaim pump back to the feed center sieve.

1. If using a bulk feed system, turn OFF the virgin transfer pump switch.
2. Remove the level sensor and bracket from the feed hopper. Disconnect the fluidizing air hose from the feed hopper.
3. Remove the lance(s) from the lance guide and install them in the purge chute(s). Rotate the locks in place over the lance ends.
4. Turn OFF the sieve switch.
5. Unclamp the sieve deck. Rotate the sieve discharge chute so powder falls into the collector chute.
6. Reclaim the sieve deck and turn ON the sieve switch.
7. Make sure the manual gun operators have their spray guns pointed into the booth, or have placed them in holders that hold them pointed into the booth.
8. Press the Color Change Start button. This starts the gun and pump purge/blowoff cycle.
9. When the gun/pump purge/blowoff cycle is complete, clean the booth.
10. When the booth is clean, shut OFF the sieve switch. This stops the sieve and the reclaim transfer pump. Leave the reclaim pump switch in the ON position.
11. Disconnect the virgin and reclaim transfer tubing from the sieve deck. Connect the tubing to the purge stubs on the back wall.
12. If using a bulk feed system:
  - a. Disconnect the suction tubing from the pickup tube. Connect the tubing to a powder collection system, which could be either the feed center or the afterfilter.
  - b. Turn ON the virgin transfer pump switch. The pump will turn on when the purge cycle is activated.
13. Press the Purge Start button to purge the reclaim and virgin transfer pumps and tubing.

Purging will stop automatically at the end of the purge cycle. To abort the purge cycle press the Purge Stop button.
14. During the purge cycle, open and blow out the cyclone transfer pan. The purge air will prevent any powder in the pan from contaminating the transfer pump or suction hose.
15. Push the manual purge button on the reclaim pump panel to clean out any powder that may have been blown into the pump during the cleaning of the transfer pan.
16. Open the cyclone access door and blow out the cyclone.

17. Move the feed hopper out of the feed center. Install the lid on the feed hopper before storing it.
18. Blow off the sieve, then unclamp the sieve deck and blow it clean.
19. Remove the screen. Clean the screen and gasket.
20. Blow off the sieve discharge pan.
21. Remove the lances from the purge chutes. Blow off the lances and purge chutes.
22. Blow off the lance guides and all inside surfaces of the feed center.
23. If using a bulk feed system, clean it as directed in its manuals.
24. Perform the Completing a Color Change Cycle procedure.

### Completing a Color Change Cycle

1. Re-assemble the sieve with a clean or new screen.
2. Connect the virgin transfer tubing (and reclaim tubing if reclaiming powder) to the sieve deck inlet stubs.
3. Install the new color feed hopper under the lance guide and make sure the sieve discharge chute is positioned to dump the screened powder into the feed hopper.
4. Install the lances in the lance guide.
5. Connect the fluidizing air hose to the feed hopper.
6. Install the level sensor and bracket on the feed hopper.
7. Press the Color Change Stop button to tell the system that the color change cycle is complete.
8. Turn the Sieve switch ON.

**NOTE:** If the Reclaim or Virgin transfer pump switches were in the ON position when the Color Change Stop button was pressed, you must turn the switches OFF then ON to turn the pumps on.

9. Turn the Reclaim transfer pump switch ON.
10. If using a bulk feed system for the new color, turn the Virgin transfer pump switch ON.

## Maintenance



**WARNING:** Allow only qualified personnel to perform the following tasks. Follow the safety instructions in this document and all other related documentation.

### Daily Maintenance

**NOTE:** You may need to perform these procedures more or less often, depending on your application requirements.

Table 1 Daily Maintenance Procedures

Component	Maintenance Procedure
<b>Sieve</b>	Disassemble and clean the sieve. Inspect the sieve screen and replace it if powder is fused to it or it is damaged.
<b>Cables and Feed Hoses</b>	Check all external cables and powder and air tubing for damage. Repair or replace as necessary.
<b>Waste Hopper</b>	Turn off the exhaust fan and check the level of powder in the feed center collector hopper. If the powder level is above $\frac{1}{2}$ full, empty the hopper.
<b>HDLV Pumps</b>	Inspect the pinch valve bodies for signs of powder leakage. Refer to the Prodigy HDLV pump manual for repair procedures.
<b>Cartridge Filters</b>	Pulse the filters as needed to prevent powder from building up on the filter media, reducing the air flow through the enclosure, and allowing powder to escape from the enclosure.
<b>HDLV Transfer Pumps</b>	Purge pumps. Inspect the pinch valve section for signs of powder leakage. If powder is present in the pinch valve section, replace pinch valves.
<b>Transfer Pan</b>	Clean pan and fluidizing plate.

## Periodic Maintenance

**NOTE:** You may need to perform these procedures more or less often, depending on your application requirements.

Table 2 Periodic Maintenance Procedures

Component	Maintenance Procedure
<b>Airflow</b>	Take regular airflow readings. A properly functioning powder feed center should provide a face velocity of around 125 fpm. A lower reading indicates clogged filters or a malfunctioning fan.
<b>Fan Motor</b>	<p>Perform the following checks regularly. Problems will be apparent if you notice changes in the following factors.</p> <ul style="list-style-type: none"> <li>• Pay attention to changes in vibration and noise levels.</li> <li>• Take current readings regularly.</li> <li>• Check all electrical connections regularly.</li> </ul>
<b>Cartridge Filters/Final Filters</b>	<p>The final filters are monitored by a pressure sensor. The fan motor will shut down if the pressure exceeds 3 in. W.C., indicating that the final filters are clogging.</p> <p>Remove the final filters and check the filters and fan compartment for signs of powder leaks. If more than traces of powder dust are visible, check the cartridge filter media and gaskets for damage and replace them if necessary. Replace the final filters if necessary.</p>
<b>Compressed Air System</b>	Open the drop leg and use a clean, white cloth to check for contaminants. Correct any problems immediately. Drain the air filters and change the elements as necessary.
<b>Electrical System</b>	Tighten all electrical connections and inspect for loose or broken wires. Check the electrical system for electrical safety every 12 months. The system must comply with all local, state, and federal codes.
<b>System Grounds</b>	Check all equipment grounds. Electrical equipment must be grounded to code. For maximum transfer efficiency and safety, electrostatic equipment must be grounded to provide a complete circuit from the spray guns through the workplace hangers, conveyors, and booth back to the gun controllers. Refer to publication number THAT-06-3881 on the Nordson emanuals web site for more information on powder coating system grounding.
<b>Air Tubing</b>	Pressurize the system and listen for air leaks. Replace or repair leaking tubing or fittings.

## HDLV Transfer Pump and Transfer Pan Maintenance

For more detailed maintenance and repair information, refer to the Prodigy HDLV High-Capacity Pump manual.

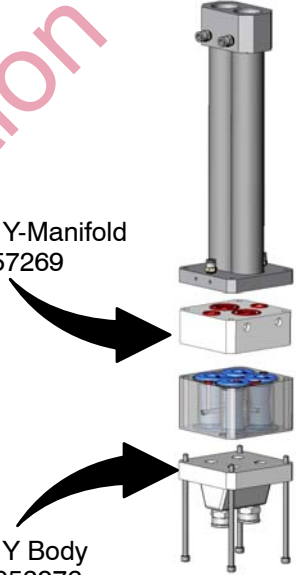
Component	Maintenance Procedure	
HDLV Reclaim and Bulk Feed Pumps	<p><b>Daily</b></p> <p>Inspect the pinch valve body for signs of powder leakage. If you see powder in the pinch valve body or stress cracks in the pinch valves, replace the pinch valves.</p>	 <p>Pinch Valves Kit 1057265</p>
	<p><b>Every Six Months or Each Time You Disassemble the Pump</b></p> <p>Disassemble the pump assembly and inspect the lower Y body and upper Y-manifold for signs of wear or impact fusion. Clean these parts in an ultrasonic cleaner if necessary.</p> <p><b>NOTE:</b> To reduce downtime, keep a spare upper Y-manifold and lower Y body in stock to install while you are cleaning the other set.</p>	 <p>Upper Y-Manifold Kit 1057269</p> <p>Lower Y Body Part 1053976</p>
Transfer Pan	<p>Periodically disassembly and clean the transfer pan. Refer to Transfer Pan Cleaning for instructions.</p> <p><b>NOTE:</b> The frequency with which you clean the transfer pan will depend on several factors, including powder type used, color change frequency, and experience.</p>	
Transfer Pan Fluidizing Plate	<p>Periodically clean the fluidizing plate and inspect it for signs of air contamination. If the plate is discolored and appears to be contaminated, replace it. Refer to <i>Transfer Pan Cleaning</i> for replacement instructions. Check your air supply and correct any contamination problems.</p>	

## Transfer Pan Cleaning

### Disassembly

1. See Figure 15. Disconnect the fluidizing air tubing (12).
2. Disconnect the 16-mm powder tubing (6) from the bulkhead union (7). Remove the bulkhead union from the discharge tube (4).
3. Remove the plenum (3) from the transfer pan (11) by removing the eight bolts (10) and nuts (9).
4. Remove the jam nut (8) and sealing washer (4) from the discharge tube. Use two wrenches: one on the flats of the discharge tube and the other on the jam nut.
5. Lift the fluidizing plate (1) with gasket (2) and discharge tube out of the plenum. Unscrew the discharge tube from the fluidizing plate.
6. Remove the gasket from the fluidizing plate and inspect both parts. If either part is damaged, replace it.

**NOTE:** If you replace the fluidizing plate, replace the gasket, too.

### Cleaning



**CAUTION:** Remove the plenum and fluid plate before cleaning the transfer pan. The solvent used to clean the transfer pan will damage the fluid plate and gasket.

Clean any impact-fused powder from the inside of the transfer pan with clean cloths and solvent.

### Assembly



**CAUTION:** Install the discharge tube into the threaded side of the fluidizing plate. (The threaded side is marked with a black dot.) Installing the discharge tube incorrectly may damage the fluidizing plate or discharge tube and cause leakage around the fluidizing plate.

1. Install the discharge tube (5) into the threaded side of the fluidizing plate (1) until the discharge tube is either
  - flush with the opposite side of the fluidizing plate, or
  - bottoms out against the fluid plate.Do not over tighten the discharge tube.
2. Install the fluidizing plate, gasket (2), and discharge tube assembly into the plenum (3).
3. Install the sealing washer (4) and jam nut (8) onto the end of the discharge tube. Tighten the jam nut snugly using two wrenches: one on the flats of the discharge tube and the other on the jam nut. Do not over tighten the jam nut.

4. Install the plenum assembly onto the bottom of the transfer pan (11) using the eight bolts (10) and nuts (9).
5. Install the bulkhead union (7) onto the discharge tube and connect the 16-mm powder tubing to the bulkhead union.
6. Connect the fluidizing air tubing (12).

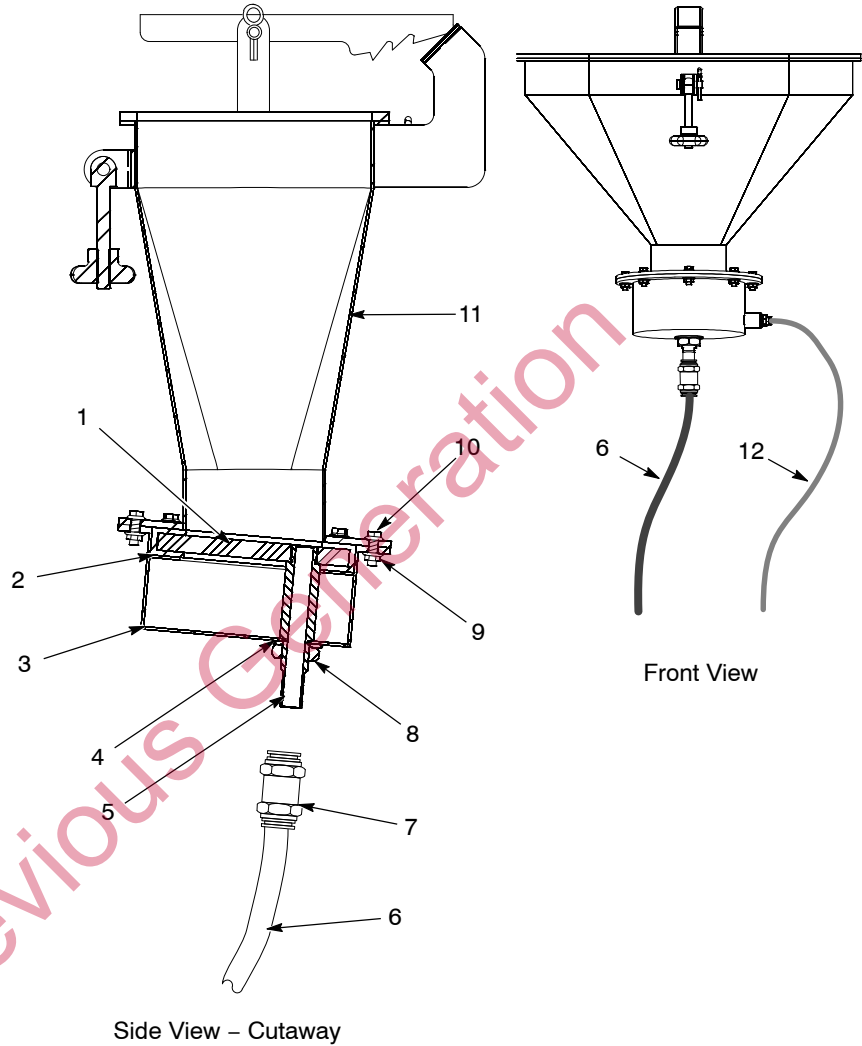

Figure 15 Transfer Pan

- |                        |                           |
|------------------------|---------------------------|
| 1. Fluidizing plate    | 7. Bulkhead union         |
| 2. Gasket              | 8. Jam nut                |
| 3. Plenum              | 9. Nuts                   |
| 4. Sealing washer      | 10. Bolts                 |
| 5. Discharge tube      | 11. Transfer pan          |
| 6. 16-mm transfer line | 12. Fluidizing air tubing |

# Troubleshooting



**WARNING:** Allow only qualified personnel to perform the following tasks. Follow the safety instructions in this document and all other related documentation.

If you cannot solve your problem with the information in this manual or related equipment manuals, contact the Nordson Finishing Customer Support Center at (800) 433-9319 or your local Nordson representative.

## Troubleshooting Chart

Problem	Possible Cause	Corrective Action
1. Feed center fan stops running or will not start	E-Stop button pressed	Reset E-Stop.
	Final filters clogged	Check final filters. Fan will be shut off if pressure across filters reaches 3 in. w.c. If filters are clogged check cartridge filter media and gaskets for leaks. Replace damaged cartridge filters. Replace final filters.
	Fan start/stop button or wiring defective	Check fan motor control circuits (main system electrical panel).
	Fan motor overload tripped	Overload occurs when motor operates at a greater amperage than designed for. Make sure overload is set to proper limit. Make sure nothing is stopping motor and fan from turning. Check fuses. Failure of one of three fuses in a 3-phase motor circuit can cause overload to trip. Check the motor and electrical connections. Reset overload.
	Fan motor fuse failure	Check motor and electrical circuits. Replace fuses.
	Fan motor failure	Replace motor.

Problem	Possible Cause	Corrective Action
<b>2. Powder escaping from enclosure openings</b>	Cartridge filters clogged; pulsing not cleaning filters	<p>Pulse cartridge filters to blow off powder.</p> <p>Check pulse air pressure</p> <p>Check the cartridge filter pulse sequence. Refer to Main System Panel PLC Programming in Prodigy ColorMax system manual.</p> <p>If Off duration is too short pulse manifold may be built up enough pressure to blow off cartridge filters.</p> <p>If On duration too short not enough air will be released to blow off filters.</p> <p>If On duration too long pulse manifold may not be able to build up air pressure.</p> <p>Replace cartridge filters if pulsing does not correct problem.</p>
	Pulse pressure too low	Set the pressure to 4.1 bar (60 psi).
	Pulse valve failed	Replace the pulse valve.
	Cartridge filters leaking	Check the cartridge filter gaskets and media for damage. Tighten the mounting nut to compress the gaskets. Replace filters as necessary.
	Cross drafts interfering with exhaust fan draw	Check for cross drafts at the enclosure opening. Eliminate or divert drafts.
	Fan rotation backward	Reverse motor rotation.
	Access panels not sealed	Tighten all access panels. Check and replace the panel gaskets as necessary.
<b>3. No feed hopper fluidizing air</b>	Spray booth and/or feed center fan not running	Start spray booth and feed center exhaust fans (main system panel).
	Fan interlock circuit or solenoid valve circuit defective	<p>Check fan interlock wiring between feed center panel and main system panel.</p> <p>Check wiring from feed center panel to solenoid valve assembly on top of feed center.</p>
	Fluidizing air solenoid valve defective, or air not being supplied to solenoid valve assembly, or fluidizing air regulator defective.	<p>If wiring to valve is OK and voltage is present at valve but valve does not open replace valve.</p> <p>If valve opens but no air flows from valve check air supply to valve assembly from accumulator tank.</p> <p>If air flows from valve but no air is supplied to feed hopper check fluidizing air regulator.</p>

Problem	Possible Cause	Corrective Action
<p><b>4. Powder in feed hopper not fluidizing, or clouds of powder erupting from surface</b></p>	<p>Fluidizing air pressure too low or too high</p>	<p>Increase the fluidizing air pressure until the powder is gently boiling. Decrease the pressure if clouds of powder are erupting from the surface.</p>
	<p>Moist or oil-contaminated powder</p>	<p>Check the air supply for water or oil. Check the filters, separators, and air dryer. Replace the powder in the feed source if it is contaminated. Refer to the next possible cause.</p>
	<p>Fluidizing plate gasket leaking, or fluidizing plate plugged, cracked, or installed incorrectly</p>	<p>Check for air leaks around the fluidizing plate gasket. If leaks are found, replace the gasket.  Inspect the fluidizing plate for stains, discoloration, polished surfaces, or cracks. Replace it if it is contaminated, plugged, or damaged. The plate should be installed with the smooth surface up (in contact with the powder).</p>
	<p>Incorrect ratio of reclaimed to virgin powder</p>	<p>Increase or decrease the transfer rate. The powder supply should be no more than three parts reclaim-to-one part virgin powder.</p>
	<p>Uneven distribution of powder in feed source</p>	<p>Check the powder and the fluidizing plate for contamination as previously described.</p>
<p><b>5. Feed center waste pump does not start, no fluidizing air to collector hopper</b></p>	<p>Spray booth and/or feed center fan not running, or fan interlock circuit defective</p>	<p>Turn on exhaust fans. Check fan interlock wiring between feed center panel and main system panel.</p>
	<p>Waste pump start or stop pushbutton defective, or solenoid valve 608 in solenoid panel failed, or no air supply to valve</p>	<p>Check solenoid valve and waste start/stop pushbutton circuits. Replace failed components or repair wiring.  Check air supply to solenoid valve panel.</p>
	<p>Pilot valve controlling air supply to pump and fluidizing air regulators failed</p>	<p>Check pilot valve. If air being supplied to valve but valve does not open replace valve.</p>
<p><b>6. Waste powder transfer stops too soon</b></p>	<p>Waste powder transfer delay timer setting too short</p>	<p>Timer automatically shuts off pump and fluidizing air. To change timer setting, refer to Main System Panel PLC programming instructions in Prodigy ColorMax manual.</p>

Problem	Possible Cause	Corrective Action
<b>7. Sieve turned ON, but no vibration</b>	E-Stop button pressed	Reset E-Stop button.
	Spray booth or feed center exhaust fan not running	Start spray booth and feed center exhaust fans.
	Sieve switch or wiring defective	Check switch and wiring. Replace switch or repair wiring as needed.
	Sieve motor overload	<p>Overload occurs when motor operates at higher amperage than designed for.</p> <p>Make sure nothing is preventing motor vibration.</p> <p>Check motor and electrical connections.</p> <p>Check motor internal weights for proper adjustment.</p> <p>Make sure overload protector is set to proper limit.</p> <p>Check fuses. Failure of one of three fuses in 3-phase motor circuit can cause overload to trip.</p> <p>Reset overload.</p>
	Sieve motor fuse failed	Check motor and electrical circuits. Replace fuses if failed.
	Sieve motor failed	Replace sieve motor.
<b>8. Powder build up on sieve mesh</b>	Mesh not cleaned frequently enough	Clean the sieve mesh at more frequent intervals. Upgrade to Vibrasonic sieve screen if necessary.
	Mesh size too small for powder being used	Use a sieve screen with a larger mesh size. Upgrade to Vibrasonic sieve screen if necessary.
<b>9. Excessive sieve noise</b>	Sieve deck or discharge pan not secure	Tighten the clamps securing the sieve deck and discharge pan to the sieve.
	Knobs or clamps not tightened; isolators loose or damaged; rubber sleeves damaged	Make sure the clamps are tight. Check the isolators for looseness or damage. Tighten the isolator mounting screws. Check the rubber sleeves for damage and replace them if necessary.
<b>10. Contaminants in feed hopper powder</b>	Sieve screen torn	Replace the screen.
	Sieve screen not thoroughly cleaned before installation	Remove and clean the sieve screen.

Problem	Possible Cause	Corrective Action
<b>11. Reclaim or Virgin transfer pump turned on, but pump does not run</b>	E-Stop button pressed	Reset E-Stop button.
	Spray booth and/or feed center fan not running, or fan interlock circuit defective	Turn on exhaust fans. Check fan interlock wiring between feed center panel and main system panel.
	Sieve motor not running	Reclaim or Virgin pumps will not run unless sieve is on. Turn On sieve.
	Reclaim or Virgin switch or wiring is defective	Check switch and wiring. Repair or replace as needed.
	Reclaim or Virgin circuits disabled	Circuits are disabled if the switches are in the On position when feed center power is turned on or when the Color Change Stop button is pressed. Turn the Reclaim or Virgin switch Off then On to reset.
	No air supply to solenoid valve assembly, or solenoid valve not opening	Check air supply to solenoid valve assembly on top of feed center. Check solenoid valve and wiring. Replace valve or repair wiring as needed.
	Problem with remote pump controls or HDLV transfer pump.	Check pump and controls. Refer to High Capacity HDLV pump manual.
<b>12. Reclaim or Virgin transfer pump cannot be purged manually by pressing Purge button</b>	Reclaim or Virgin pump not turned on	Turn Reclaim or Virgin pump switch to On position. Press Purge button to purge. Purge will be on while button is pressed.
<b>13. Reclaim or Virgin transfer pump turned off but continues to run</b>	Solenoid valve in manual override	Check solenoid valve assembly on top of feed center. Make sure manual operator on valve is not in override position.
	Solenoid valve failed open	Replace valve.
<b>14. Virgin transfer pump is turned on but pump not running</b>	Level sensor on feed hopper is detecting powder in hopper	Pump will not be turned on until powder level falls below level sensor and delay timer runs out.
	Refer to Problem 8 for other causes	
<b>15. Virgin transfer pump does not stop automatically</b>	No powder supply at bulk feed system	Check bulk feed supply.
	Feed hopper level sensor not adjusted properly	Level sensor stops pump when it detects powder. Sensor indicating light should be yellow when powder is detected. Adjust the level sensor if it is not detecting powder. Refer to level sensor documentation.
	Level sensor failed or wiring defective	Check level sensor and wiring. Repair or replace as needed.

Problem	Possible Cause	Corrective Action
<b>16. Reclaim and/or Virgin transfer pump purge cycle does not start when Purge Start button pressed</b>	Reclaim and Virgin transfer pumps not turned on	Pumps must be on before purge can start. Turn on pump to be purged.
	Purge Start button or wiring defective	No signal from button to controller. Pressing the button should turn on signal. Check button and wiring, repair or replace as needed.
	Purge Stop button or wiring defective	No signal from button to controller. Signal must be on as long as button is not pressed. Check button and wiring, repair or replace as needed.
	Purge solenoid valves or wiring defective	Check wiring from feed center control panel to solenoid valve assembly on top of feed center. Check solenoid valve operation. Check air supply to solenoid valve assembly. Repair or replace as needed.
	Purge air pilot valve or pilot air tubing defective	Check pilot air tubing. Make sure air signal is reaching pilot valve. Check pilot valve operation. Check air supply to pilot valve. Repair or replace as needed.
<b>17. Feed center low powder level alarm buzzer on</b>	Alarm buzzer delay timer has run out, level sensor not detecting powder	Alarm buzzer timer starts when the transfer pump turns on. If the timer runs out and the level sensor has still not detected powder then the alarm buzzer is turned on. The timer default is 3 minutes.  To turn off buzzer press Color Change Stop button.
	Problem with powder supply or Virgin transfer pump	Refer to Problems 8, 10, 11, 12.
<b>18. Color change does not start when Color Change Start button pressed, light off</b>	E-Stop button pressed	Reset E-Stop button.
	Spray booth and/or feed center fan not running, or fan interlock circuit defective	Turn on exhaust fans. Check fan interlock wiring between feed center panel and main system panel.
	Color Change Start button or wiring defective	No signal from button to controller. Pressing the button should turn on signal. Check button and wiring, repair or replace as needed.
	Color Change Stop button or wiring defective	No signal from button to controller. Signal must be on as long as button is not pressed. Check button and wiring, repair or replace as needed.

Problem	Possible Cause	Corrective Action
<p><b>19. Color change does not start with Color Change Start button pressed, light on</b></p>	<p>Parts still in booth</p>	<p>iControl system tracks parts through booth and will delay color change start until parts clear booth. Booth length is configurable through iControl Configuration. Refer to iControl Operator Interface manual for more information.</p>
	<p>iControl gun positioners not in manual or auto mode</p>	<p>Set the gun positioners to either manual or auto mode.</p>
	<p>iControl gun positioner #1 controller did not receive Color Change Start signal from feed center</p>	<p>The feed center passes signals for color change to the gun positioner #1 electrical panel which then communicates with the iControl system.  Check the wiring and connections between the feed center control panel and the gun positioner #1 panel.</p>
	<p>Reciprocator not in auto mode</p>	<p>Reciprocator must be in auto mode for color change cycle to start. Set the reciprocator to auto mode.</p>
<p><b>20. Color change cycle started, gun positioner stopped at forward limit switch</b></p>	<p>Oscillator not at bottom of stroke (USA only)</p>	<p>Oscillator must be at bottom of stroke for spray guns to be in position for gun blowoff. Blowoff will not start until bottom of stroke sensor is on and remains on.  Check oscillator position.</p>
	<p>USA ColorMax not selected on iControl gun positioner configuration screen</p>	<p>Check gun positioner configuration.</p>
	<p>Oscillator not stopped</p>	<p>Oscillator gets stop command from gun positioner #1 control panel. Check wiring and connections between gun positioner control panel and main system panel.  USA only – Oscillator bottom of stroke sensor not sending signal to main system panel. Sensor detects rotating lever arm. Make sure sensor is positioned to detect arm and check wiring and connections to sensor.</p>
	<p>Reciprocator not at Park position</p>	<p>Reciprocator must be at Park position for spray guns to be in position for gun blowoff. Blowoff will not start until Park position is achieved.  Check reciprocator position. Make sure Park position is configured within stroke range. Refer to iControl Operator Interface manual for reciprocator configuration settings.</p>

Problem	Possible Cause	Corrective Action
<b>21. Color change cycle started, blowoff air does not turn on</b>	No air supply to solenoid valve or pilot valve, failed valve, or bad electrical connection	<p>Solenoid valve (typically located in the main system panel) is activated by signal from the gun positioner control panel. Solenoid valve sends air signal to large pilot valve that provides air to the blowoff nozzles.</p> <p>Make sure main system panel air supply is on.</p> <p>Check solenoid valve output. If solenoid coil is energized but no air flows from valve, replace valve.</p> <p>Check air tubing to pilot valve.</p> <p>Check pilot valve operation.</p> <p>Check the wiring and connections between the gun positioner panel and main system panel.</p>

Previous Generation

# Repair



**WARNING:** Allow only qualified personnel to perform the following tasks. Follow the safety instructions in this document and all other related documentation.

## Cartridge Filter Replacement

See Figure 16.

1. Remove the pulse valve and cartridge filter access panels at the rear and side of the enclosure.
2. Pull up on the mounting rod (6) T-handle to hold the cartridge filter up against the mounting plate, or support the filter from underneath.
3. Remove the nut, flat washer, and mounting bracket (1, 2, 3). Save these parts for reuse.
4. Carefully lower the cartridge filter (4) away from the mounting plate and out of the filter section. The centering bracket and mounting rod (5, 6) will stay in place.
5. Unscrew the mounting rod and remove it and the centering bracket from the cartridge filter.
6. Thoroughly clean the sealing surface on the underside of the mounting plate. A dirty surface will prevent the cartridge filter gasket from sealing properly and allow powder to leak into the fan section.
7. Remove the new cartridge filter from its carton and inspect it for damage. Do not use damaged cartridge filters.
8. Set the centering bracket (5) into the open end of the new cartridge filter. Slide the mounting rod (6) through the centering bracket and screw it into the bottom of the cartridge filter.
9. Center the cartridge filter under the opening in the mounting plate. Use the T-handle to pull up the cartridge filter against the mounting plate, or push it up from underneath.
10. Install the mounting bracket (3) on the mounting rod, making sure that the slots in the mounting bracket slip over the T-handle.
11. Install the flat washer and nut (1, 2) onto the mounting rod. Do not tighten the nut at this time.
12. Slip the ends of the mounting bracket into the locating slots around the filter opening in the mounting plate.
13. Tighten the nut until the mounting and centering brackets are touching. This will compress the gasket and seal the cartridge against the mounting plate.
14. Install the pulse valve and cartridge filter access panels.

## Cartridge Filter Replacement (contd)

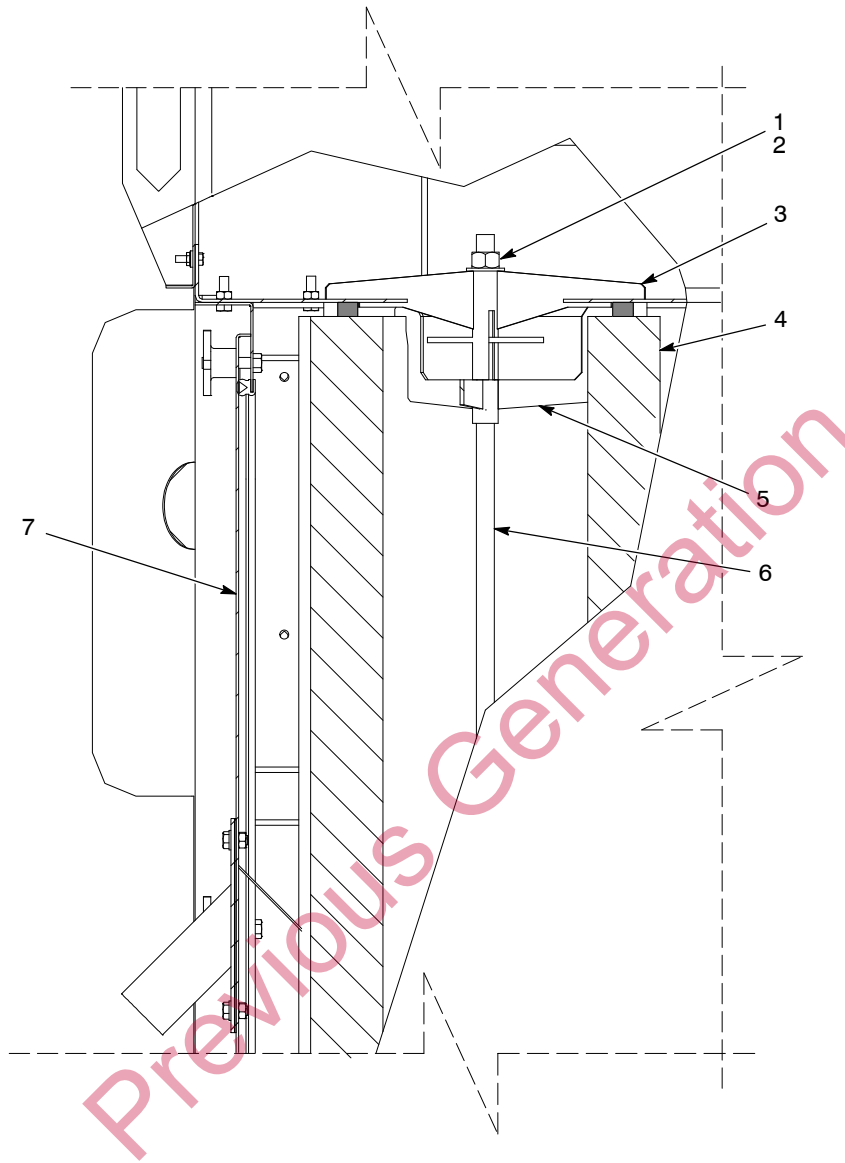

Figure 16 Cartridge Filter Replacement

- |                        |                      |                      |
|------------------------|----------------------|----------------------|
| 1. Nut 5/8 in.         | 4. Filter            | 6. Mounting rod      |
| 2. Flat washer 5/8 in. | 5. Centering bracket | 7. Side access panel |
| 3. Filter mount        |                      |                      |

## Collector Fluidizing Plate Replacement

1. Empty as much powder as possible from the waste hopper.
2. Turn off and lock out power to the powder feed center.
3. See Figure 17. Remove the cartridge filter access panel (6) and vacuum out any remaining powder.
4. Remove the screws, lock washers, and flat washers (1, 2, 3) securing the six retaining angles (4).
5. Remove the retaining angles and fluidizing plate (5).
6. Set the new fluidizing plate smooth side up into the waste hopper.
7. Set the retaining angles on top of the fluidizing plate.
8. Secure the retaining angles and fluidizing plate to the waste hopper using the screws, lock washers, and flat washers.

**NOTE:** As you tighten the screws, push down on the retaining angles to compress the fluidizing plate gasket evenly.

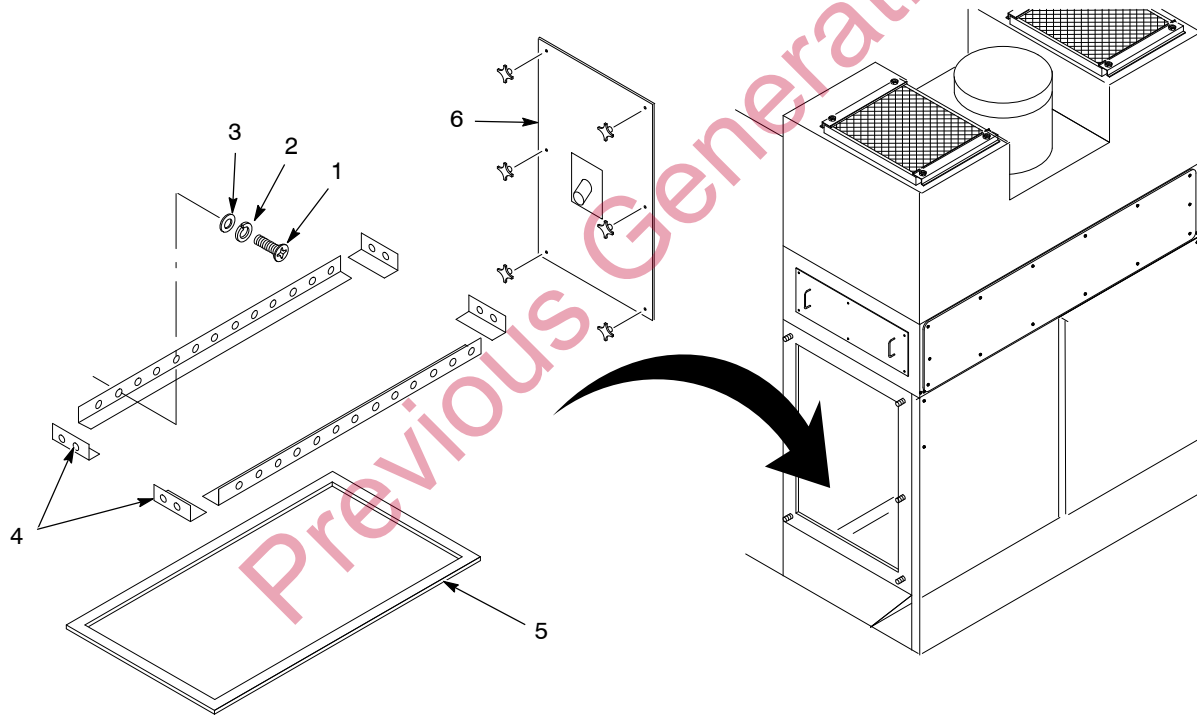

Figure 17 Collector Fluidizing Plate Replacement

# Parts

To order parts, call the Nordson Finishing Customer Service Support Center at (800) 433-9319 or contact your local Nordson representative.

## Sieve Parts

Item	Part	Description	Quantity	Note
1	1056563	SCREEN, 20 mesh	1	
1	1014561	SCREEN, 40 mesh	1	
1	1014562	SCREEN, 60 mesh	1	
2	1060113	MOTOR, vibrator, 230/460, 3 phase, 60 Hz	1	
2	1060114	MOTOR, vibrator, 220/380, 3 phase, 50 Hz	1	A
3	1014563	GASKET, screen, sieve, 15 in.	1	
4	1017602	MOUNT, isolation, sieve	1	
5	1600758	GASKET, plastic wear ring	1	

NOTE A: Used on Euro version only.

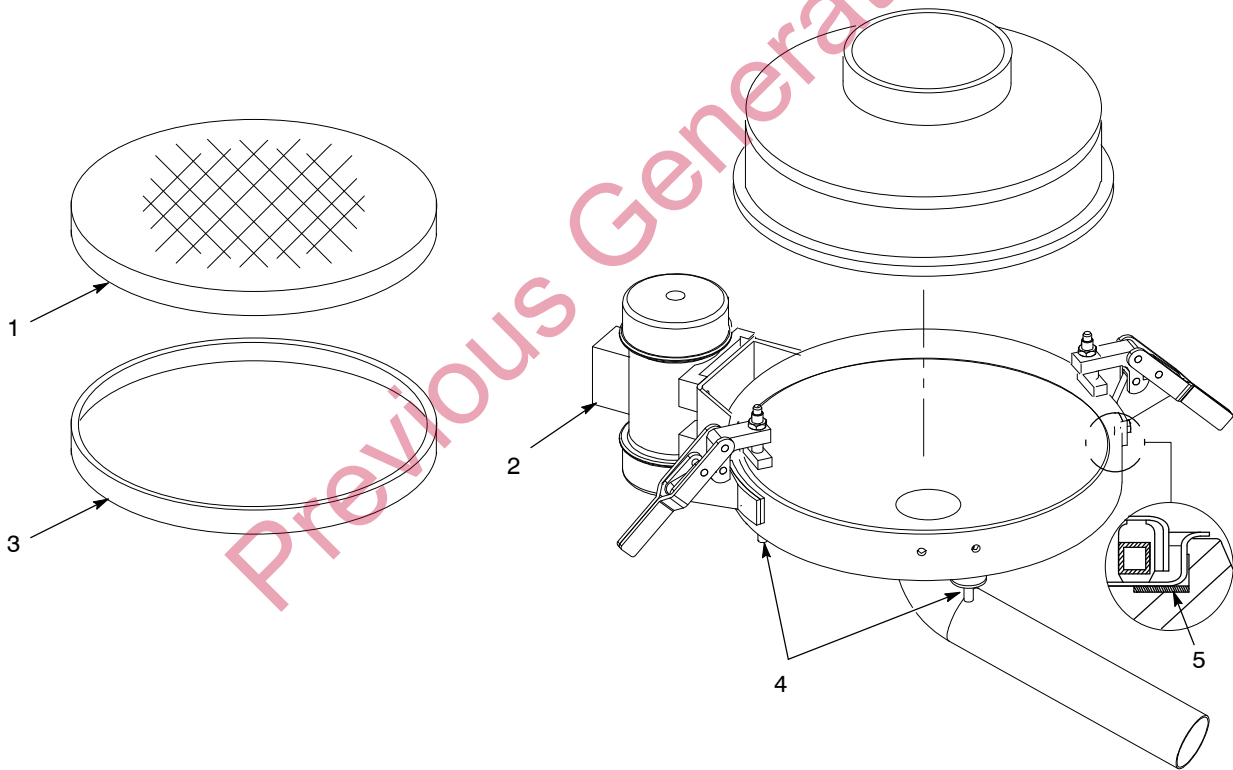

Figure 18 Sieve Parts

**Miscellaneous Parts**

Item	Part	Description	Quantity	Note
1	176367	KNOB, final filter clamp, Excel	8	
2	343309	MOTOR, 5 HP, C-face	1	
3	156995	FILTER, final, internal mount	2	
4	174710	VALVE, pulse	2	
5	165726	NOZZLE, cartridge pulse	2	
6	156996	FILTER, 36, PowderGrid, centermount	2	
7	165633	PUMP, transfer, metric	1	
7A	1071152	ADAPTER, pump, transfer	1	
8	1071115	FLUIDIZING PLATE assembly, Prodigy	1	
9	303132	VALVE, 3/4 in., air operated	AR	
10	1070780	VALVE, solenoid, assembly	1	
11	1014550	LIGHT FIXTURE, 4 ft, 2 light	1	
NS	900651	TUBING, powder, transfer, 19 mm (.75 in.) ID, blue	AR	

AR: As Required

NS: Not Shown

Continued...

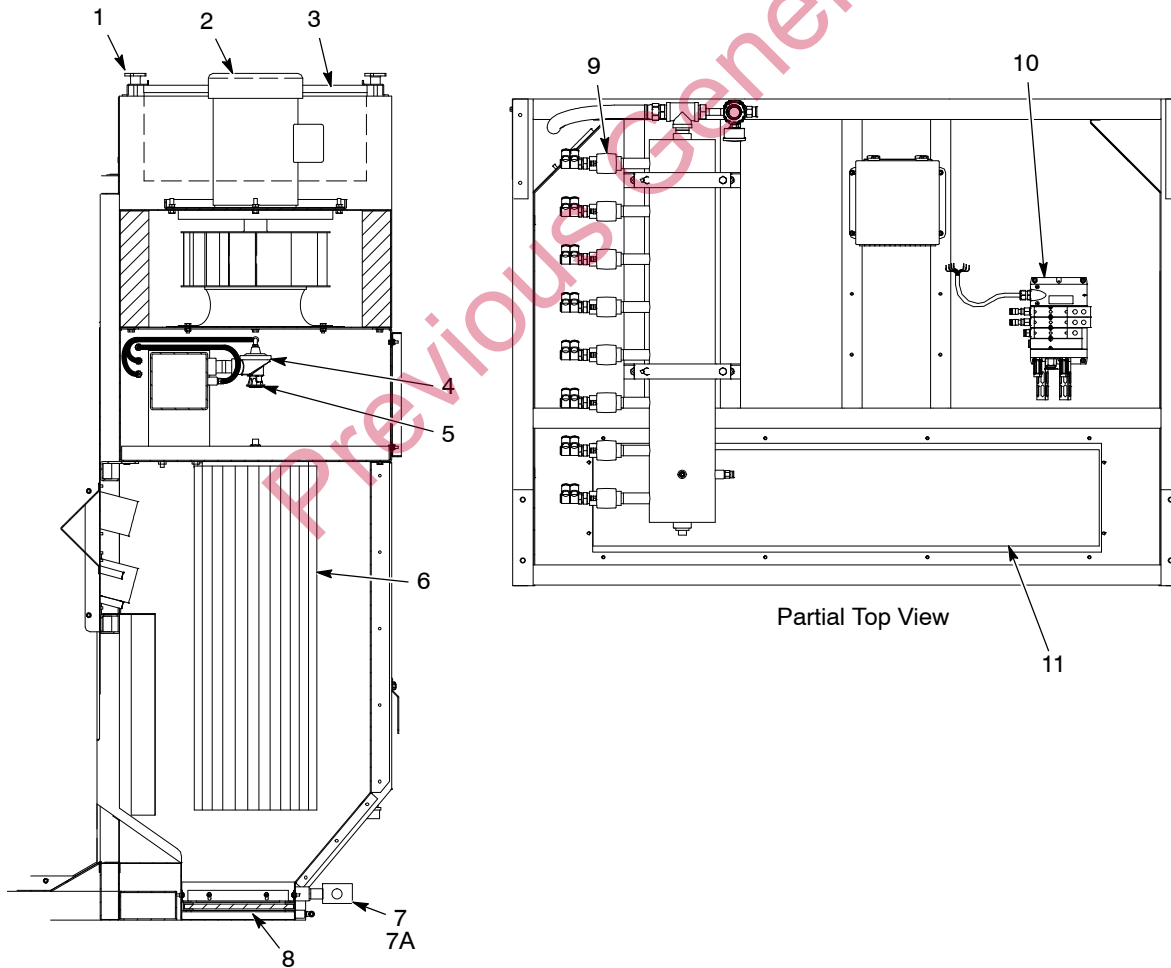

Figure 19 Miscellaneous Parts (1 of 2)

Item	Part	Description	Quantity	Note
11	1070171	LANCE, Prodigy, 4 pump	8	A
11	1070172	LANCE, Prodigy, 6 pump	1	A
11	1070173	LANCE, Prodigy, 8 pump	2	A
11	1070174	LANCE, Prodigy, 10 pump	2	A
11	1070175	LANCE, Prodigy, 12 pump	2	A
11	1070176	LANCE, Prodigy, 14 pump	2	A
11	1070177	LANCE, Prodigy, 16 pump	1	A
12	1071323	WIPER, rubber, lance	AR	
13	1071873	HOPPER assembly, 18 L x 18 W x 17.5 H	AR	
14	1071872	• PLATE, fluidizing, 0.50 thick x 18 x 18	1	
NS	1014553	PROBE, level sensor, quick disconnect, M18	1	
NS	1023925	CABLE, 4 pin, M12 connector, 5M long	1	
NS	-----	BRACKET, mounting, level sensor	1	B

NOTE A: Use 1071376 Kit, fitting upgrade, lance, to replace broken powder tube fittings in the lance head. Each kit comes with the parts to replace two fittings.

B: The level sensor probe is secured by the level sensor bracket. The probe and bracket hang on the edge of the hopper with the probe within the hopper.

AR: As Required

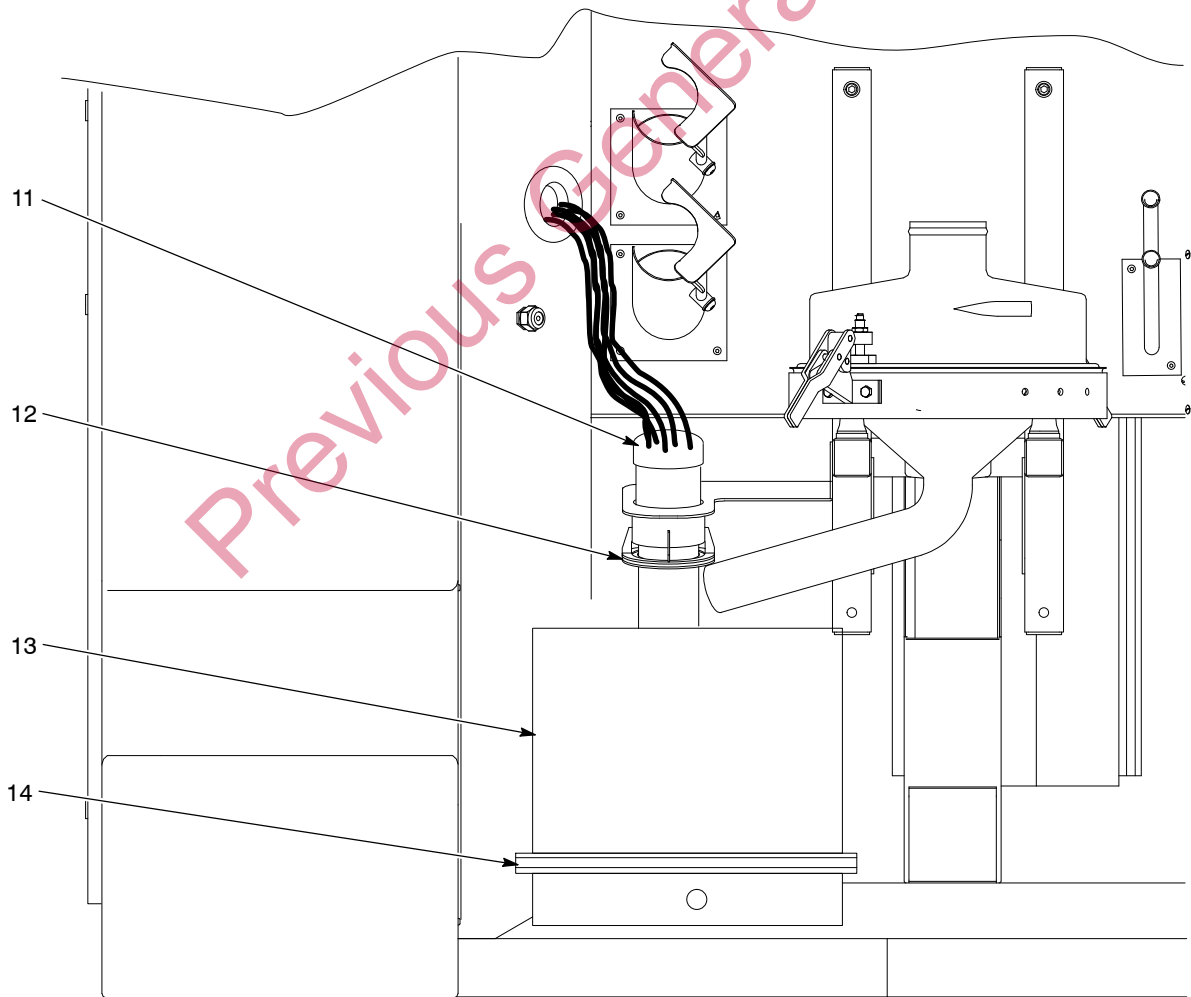

Figure 20 Miscellaneous Parts (2 of 2)

### Reclaim Pump Panel Parts

Item	Part	Description	Quantity	Note
1	303132	VALVE, 3/4-in. in/out, air operated	1	
2	1064551	VALVE, push button, control	1	
3	226715	GAUGE, air, 0–100 psi, panel mount	1	
4	1058680	REGULATOR, 7–125 psi, panel mount	1	
5	226714	GAUGE, air, 0–30 psi, panel mount	1	
6	1057513	REGULATOR, 0–30 psi, panel mount	1	
7	1058045	PUMP ASSEMBLY, high-capacity HDLV, packaged	1	A
8	972277	CONNECTOR, male, elbow, 8 mm x 1/4 in. uni	2	
9	-----	NUT, hex, serrated, 1/4-20, steel, zinc	6	
10	-----	SCREW, hex, serrated, 1/4-20 x 0.75 in., steel, zinc	4	
11	972091	CONNECTOR, male, elbow, 6 mm x 3/8 uni	2	
12	972141	CONNECTOR, male, 6 mm x 1/8 in. unit	4	
13	972157	CONNECTOR, female, 6 mm x 1/8 in. NPT	2	
14	-----	SCREW, hex head, self tapping, 1/4-20 x 1.00 in., steel, zinc	2	
15	1082885	VALVE, shuttle, 6-mm tube	1	

NOTE A: Refer to the *Prodigy High-Capacity HDLV Pump* manual, p/n 1053991, for a breakdown of the parts included in the pump assembly.

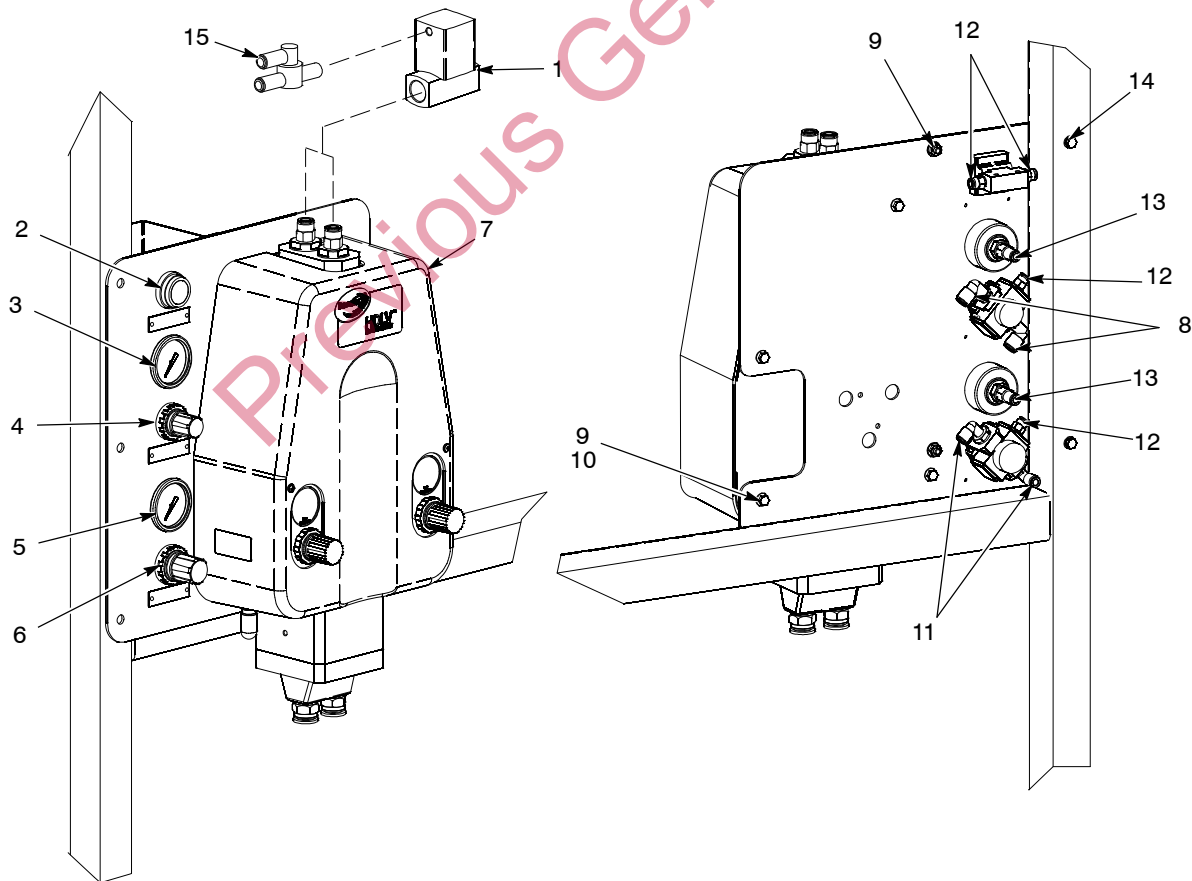

Figure 21 Reclaim Pump Panel Parts

### Transfer Pan Parts

Item	Part	Description	Quantity	Note
1	1062989	GASKET, transfer pan, HDLV	1	
2	1062693	PLATE, fluidizing, transfer pan, HDLV	1	
2	1074012	PLATE, fluidizing, dual outlet, transfer, HDLV	1	A
3	1062694	GASKET, fluid plate, pan, transfer, HDLV	1	
4	984247	NUT, hex, jam, M20	1	
5	972145	BULKHEAD UNION, 16 mm	1	
6	1062696	TUBE, discharge, transfer pan, HDLV	1	
7	-----	WASHER, sealing, 3/4 pipe size	1	
8	-----	NUT, hex, serrated, 1/4-20, steel, zinc	8	
9	-----	SCREW, hex, serrated, 1/4-20 x 0.75 in., steel, zinc	8	
10	1064551	KIT, latch, transfer pan, cyclone	1	
11	-----	• LATCH, retainer, pan	1	
12	-----	• PIN, clevis, 0.31 dia x 1.25 in. long	1	
13	-----	• PIN, cotter, 0.125 in.	1	
14	-----	• SPRING, torsion	1	

NOTE A: Used on dual outlet transfer pans only.

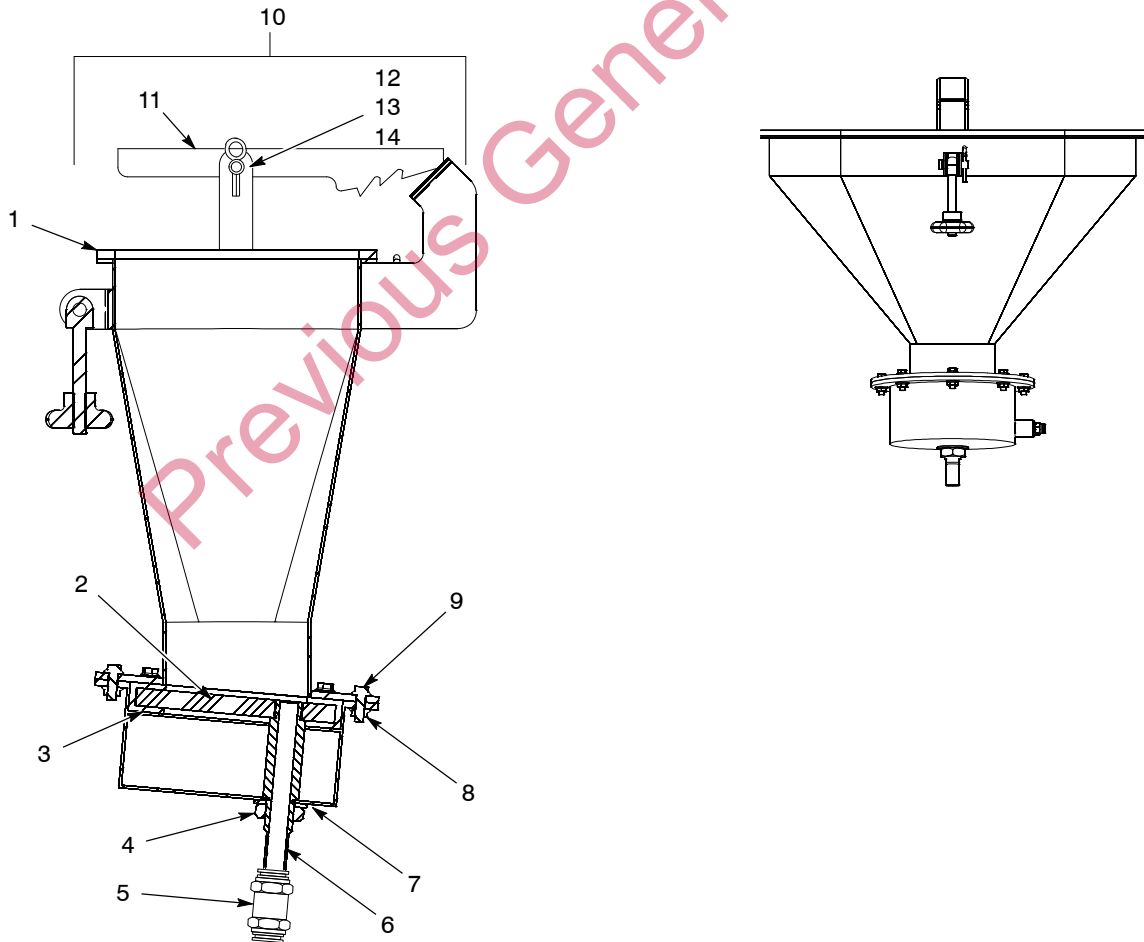

Figure 22 Transfer Pan Parts

## Optional Vibrasonic Sieve Screen

The Vibrasonic sieve screen increases sieve screen life and sieve throughput.

The Vibrasonic system constantly applies an ultrasonic frequency to the sieve screen. The ultrasonic frequency breaks down the surface tension in the screen, preventing blinding of the sieve screen.

### *Vibrasonic System Components*

See Figure 23.

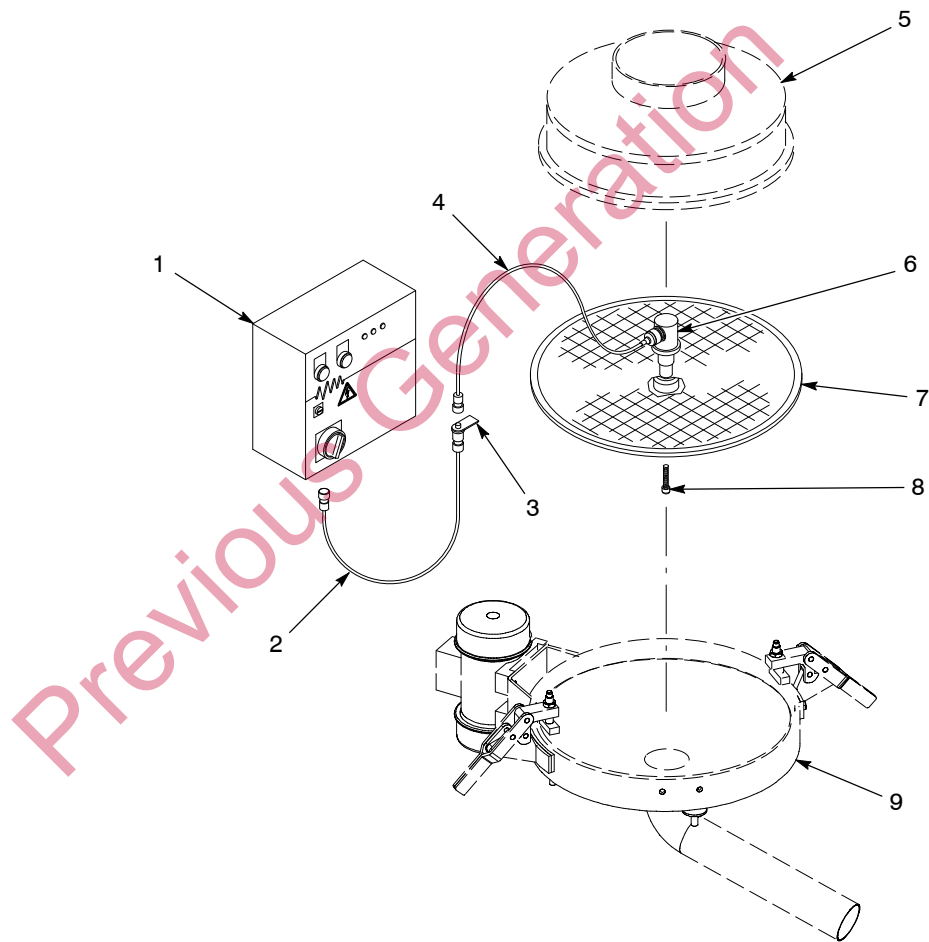

Figure 23 Vibrasonic System Components

- |                             |                          |
|-----------------------------|--------------------------|
| 1. Control box              | 6. Vibrasonic transducer |
| 2. Control cable (4 meters) | 7. Sieve screen          |
| 3. Support bracket          | 8. Cap screw             |
| 4. Transducer cable         | 9. Vibratory sieve       |
| 5. Sieve deck               |                          |

## Installation



**WARNING:** Allow only qualified personnel to perform the following tasks. Follow the safety instructions in this document and all other related documentation.

**NOTE:** Inspect all Vibrasonic system components for damage before installation. Contact your Nordson representative if any components are damaged.

### Vibrasonic Transducer and Sieve Screen Installation

1. See Figure 23. Clean the center hub of the screen (7) and the bottom of the transducer (6) with acetone.

**NOTE:** The transducer must be secured to the flat side of the sieve screen.

2. Set the transducer onto the center hub of the sieve screen. Install the cap screw (8) into the transducer and hand-tighten it.
3. Hold the base of the transducer with the supplied pin wrench and turn the cap screw with the supplied torque wrench until you hear a click.
4. Install the sieve gasket onto the sieve screen.
5. Set the sieve screen into the sieve (9). Route the transducer cable (4) through the sieve deck (5) and clamp the sieve deck onto the sieve.

### Control Box and Cable Installation

1. Mount the control box (1) near the feed center control panel.
2. Supply electrical power to the control box from the feed center control panel (refer to electrical drawings in this manual). Make sure the voltage selector on the control box is set to the power supply voltage.
3. Connect the control cable (2) to the control box. Route the other end into the feed center.
4. Mount the control cable support bracket (3) to the sieve support bracket. Make sure the transducer cable (4) reaches the support bracket.
5. Connect the transducer and control cable plugs, then rotate the transducer cable plug to align the location dots on both plugs.

## Operation

To turn on the Vibrasonic system, turn the red switch on the control box clockwise 90°, then turn ON the Sieve switch on the feed center control panel to supply power to the Vibrasonic system.

The POWER and VIBRASONICS indicators on the control box will light. There are five LEDs on the control box door. During operation, LED 1 will light to indicate normal operation.

## Troubleshooting

### Fault Conditions

The LEDs and indicators on the control box indicate faults with the Vibrasonic system.

Condition	POWER Indicator	VIBRASONICS Indicator	LED 1	LED 2	LED 3	LED 4	LED 5
Normal	On	On	On	Off	Off	Off	Off
Under Voltage	On	On or Off	Off	On	Off	Off	Off
Over Voltage	On	On	Off	Off	On	Off	Off
Open Circuit	On	Flashing	Off	On	Off	On	Off
Short Circuit	On	On	Off	On	Off	Off	On

### Fault Causes and Corrective Actions

Use the following chart to correct fault conditions indicated by the LEDs.

Problem	Possible Cause	Corrective Action
<b>1. Under voltage</b>	Supply voltage too low	Increase the supply voltage.
	Screen center hub bonding damaged	Replace the sieve screen.
	Damaged generator	Contact the Vibrasonic system manufacturer.
<b>2. Over voltage</b>	Poor contact surfaces between transducer and sieve screen	Remove the transducer from the screen and clean the mating surfaces with acetone. Refer to page 52 for assembly instructions.
	Loose transducer	Tighten the transducer using the supplied torque wrench. Refer to page 52 for instructions.
	Damaged sieve screen mating surface	Replace the sieve screen.
	Damaged transducer mating surface	Replace the transducer.
<b>3. Open circuit</b>	Disconnected cable	Check the cable connections.
	Damaged control cable or connector	Replace the control cable.
	Loose or damaged wiring in the control box	Check the control box wiring. Tighten any loose connections.
	Damaged transducer	Replace the transducer.
<b>4. Short circuit</b>	Short circuit in control cable	Replace the control cable.
	Short circuit in control or transducer cable connectors	Thoroughly clean the connectors.
	Short circuit in transducer	Replace the transducer.

## VIBRASONICS/POWER Indicator Troubleshooting

Use the following chart to correct fault conditions indicated by the POWER and VIBRASONICS indicators.

Indicator Status	Possible Cause	Corrective Action
<b>POWER: on</b> <b>VIBRASONICS: off</b>	Faulty indicator bulb	Check the indicator light bulb and replace if necessary.
	Loose cable connection	Check all cable connections.
	Poor contact surfaces between transducer and sieve screen	Remove the transducer from the screen and clean the mating surfaces with acetone. Refer to page 52 for assembly instructions.
<b>POWER: off</b> <b>VIBRASONICS: off</b>	Control box power is off	Turn on power to the control box.
	Circuit breaker tripped	Open the control box and reset the miniature circuit breaker.
	Faulty indicator bulbs	Check the indicator light bulbs and replace if necessary.
<b>POWER: off</b> <b>VIBRASONICS: on</b>	Faulty indicator bulb	Check the indicator light bulb and replace if necessary.
<b>POWER: on</b> <b>VIBRASONICS: flashing</b>	Break in continuity or change in polarity in four-meter or transducer cable	Turn off control box power and check the transducer's cap screw for the proper torque. Turn on control box power and check indicators.  If the condition persists, replace the cables.

### Vibrasonic System Parts

Item	Part	Description	Quantity	Note
—	1014564	SYSTEM, Vibrasonic, with interface card	1	
1	-----	• BOX, control, Vibrasonic	1	
1A	1600480	• • BOARD, controller, Vibrasonic	1	
2	-----	• CABLE, 4-meter, with support bracket	1	
3	-----	• CABLE, transducer	1	
4	-----	• TRANSDUCER, Vibrasonic	1	
5	1014565	• SCREEN, Vibrasonic, 80 mesh, with gasket	1	A
6	-----	• SCREW, cap, socket head, M8	1	

NOTE A: Other mesh sizes are available. Contact your Nordson representative for more information.

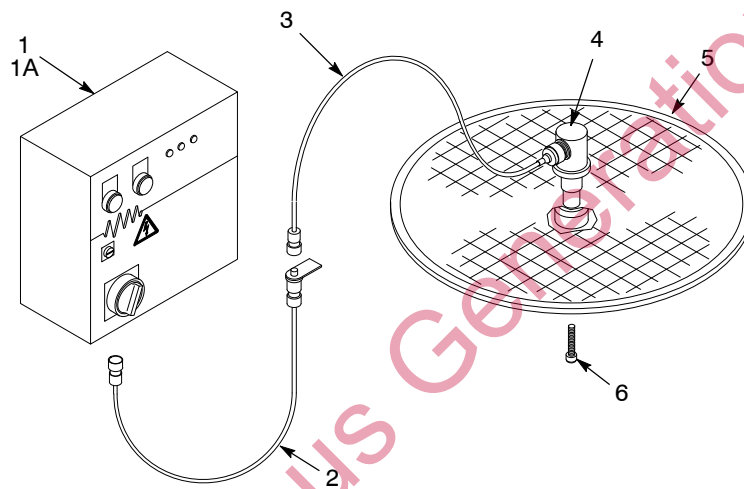

Figure 24 Vibrasonic System Parts

Previous Generation



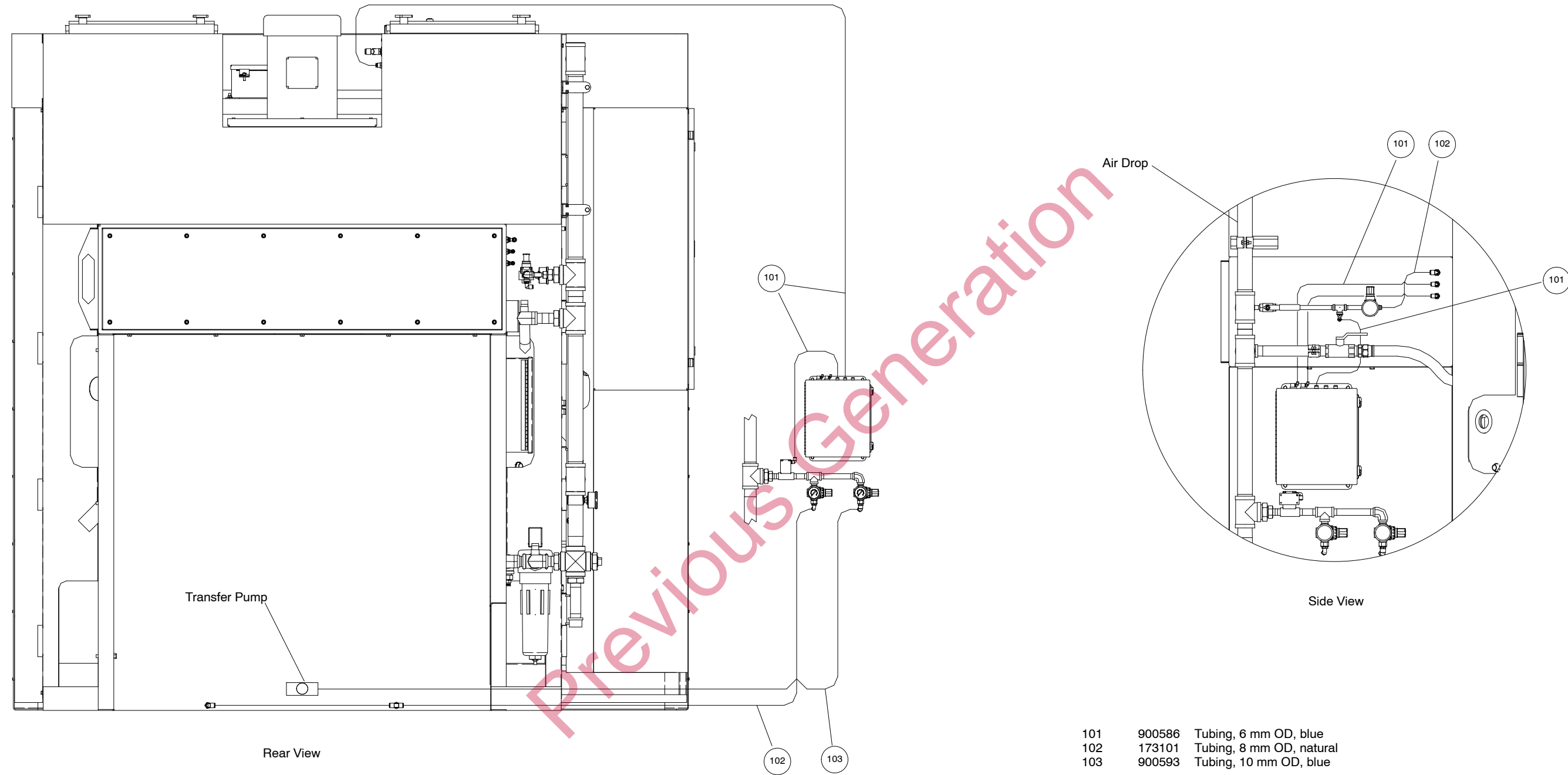
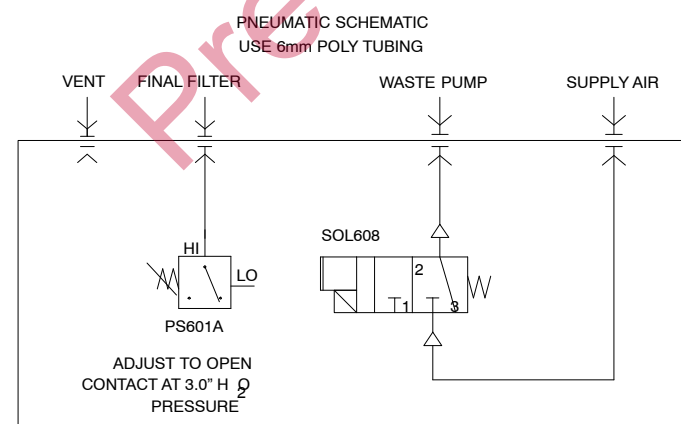
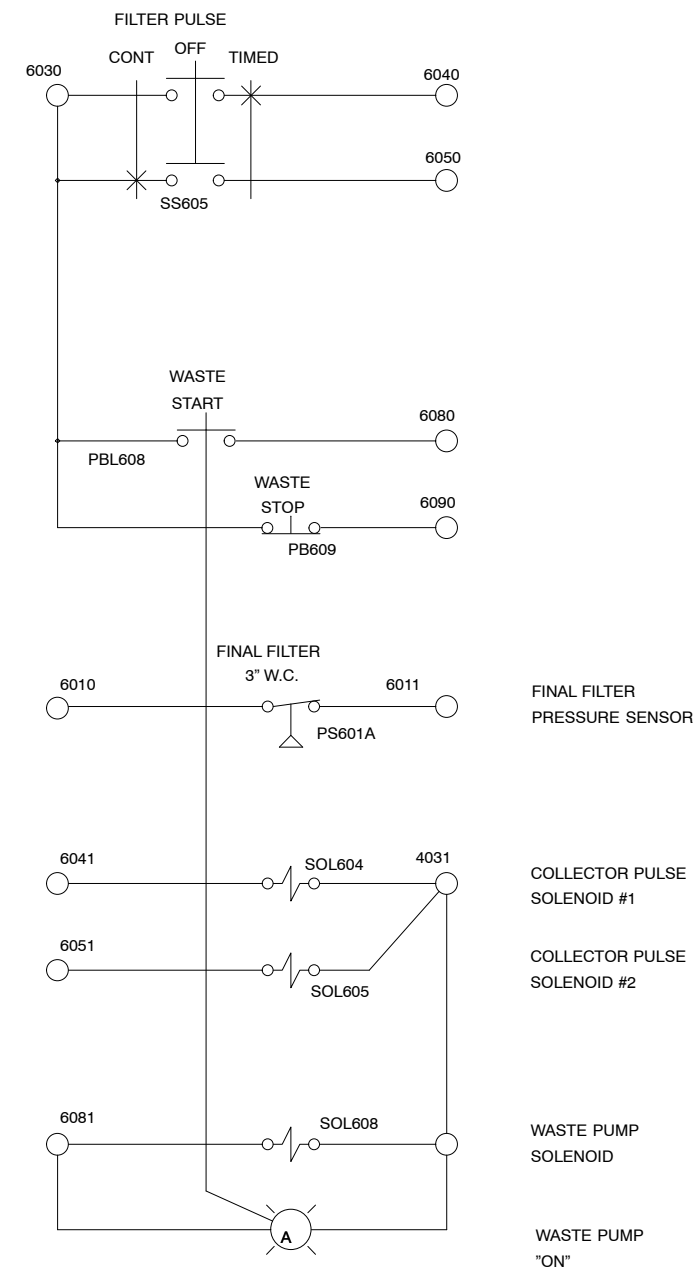
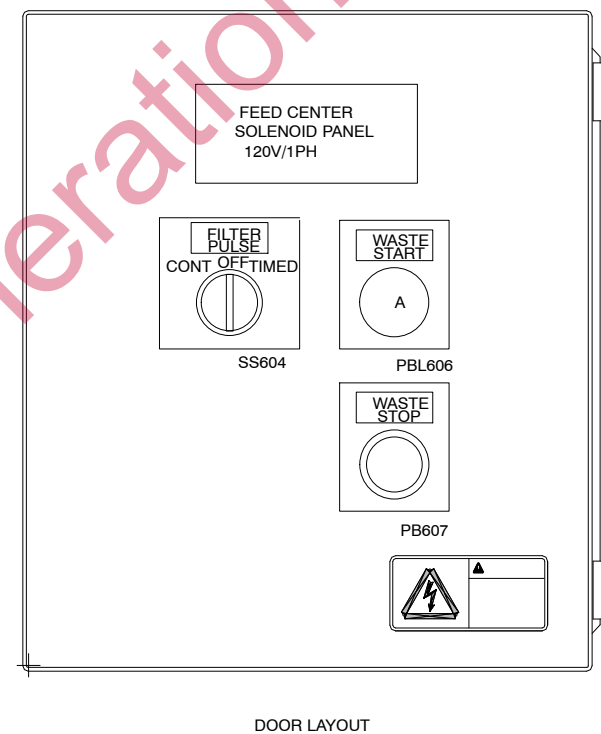
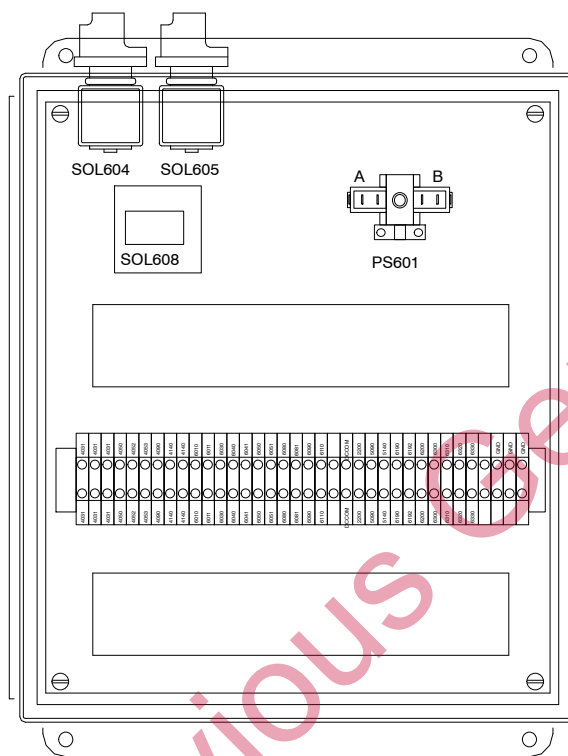
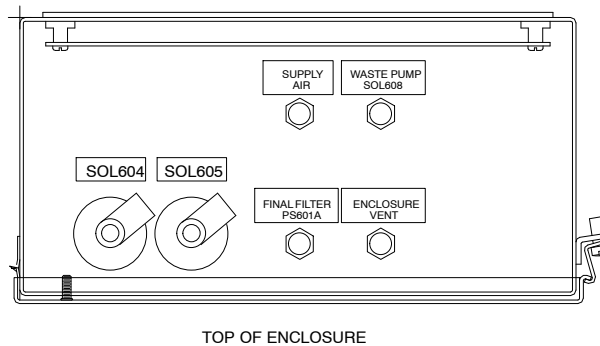

Figure 26 Pneumatic Diagram – 32 Pump System (2 of 2)

ITEM	QTY	DESCRIPTION	PART NO.	MFG.
	1	ENCLOSURE, 14 X 12 X 6	A-1412CH	HOFFMAN
	1	SUBPANEL	A-14P12	HOFFMAN
TB	A/R	WIRE DUCT, 1 1/2" x 3"	---	---
TB	3	TERMINAL BLOCK, GROUND	-----	-----
TB	33	TERMINAL BLOCK	-----	-----
TB	1	END SECTION	-----	-----
TB	2	END STOP	-----	-----
TB	A/R	DIN RAIL	-----	-----
SOL608	1	VALVE, SOLENOID, 3-WAY, 120V	35 SERIES	MAC
SOL608	1	MALE ELBOW	-----	-----
SOL604,605,608	3	MALE CONNECTOR	KQ2H06-01S	SMC
SOL604,605	2	VALVE, SOLENOID, 2-WAY, 120V	RCA-3D2	GOYEN
PS601A/B	1	PRESSURE SWITCH, DUAL SETPOINT	MPL-604-G-3/2.5	MICRO PNEUMATIC LOGIC
PS601,SOL608	3	BULKHEAD UNION, 6mm	KQ2E06-00	SMC
	1	BREATHER VENT	F28	ALWITCO
	A/R	6mm POLYTUBING	1J-242-10	SMC
PBL608	1	PUSHBUTTON, ILLUM, N.O., AMBER, L.E.D.	E22TB9X96W	CUTLER-HAMMER
PB609	1	PUSHBUTTON, N.C., RED	E22EB2B	CUTLER-HAMMER
SS605	1	SELECTOR SWITCH, 3-POS, MAINTAINED	E22XBG1D	CUTLER-HAMMER
SS605,PB609,PBL608	3	NAMEPLATE (BLACK)	E22NSP77	CUTLER-HAMMER



TB	
4031	4031
4031	4031
4031	4031
4050	4050
4052	4052
4053	4053
4090	4090
4140	4140
4140	4140
6010	6010
6011	6011
6030	6030
6040	6040
6041	6041
6050	6050
6051	6051
6080	6080
6081	6081
6090	6090
6110	6110
DCCOM	DCCOM
2200	2200
5090	5090
5140	5140
6190	6190
6192	6192
6200	6200
6300	6300
6310	6310
6320	6320
6330	6330
	GND
	GND
	GND

Figure 27 Solenoid Panel (1 of 1)

VENDOR'S BILL OF MATERIAL				
ITEM	QTY	ITEM	PART NO.	MFG.
	1	ENCLOSURE	1579.500	RITTAL
	1	MOUNTING FOOT KIT	1590.000	RITTAL
	2	SUBPANEL SUPPORT BRACKET	SPEC	SANDUSKY ELECTRIC
	1.75FT	WIRE DUCT, 1.5" X 3"	71530	TAYLOR
	1.75FT	DUCT COVER, 1.5"	79015	TAYLOR
	3.5FT	WIRE DUCT, 1" X 3"	71030	TAYLOR
	3.5FT	DUCT COVER, 1"	79010	TAYLOR
TB1	1.25FT	DIN RAIL	D5PD2-20	CUTLER-HAMMER
TB1	2	END ANCHOR	C383ES35	CUTLER-HAMMER
TB1	1	END PLATE	C383AP4	CUTLER-HAMMER
TB1	35	TERMINAL BLOCK	C383RK254	CUTLER-HAMMER
TB1	4	JUMPER	C383JC402	CUTLER-HAMMER
GTB1	1	GROUND TERMINAL	TGL1	GENERAL ELECTRIC
CB205, CB223	2	CIRCUIT BREAKER	AS168X-CB1G020	SCHURTER
CB208	1	CIRCUIT BREAKER	AS168X-CB1G050	SCHURTER
PRM301	1	PROGRAMMABLE RELAY CONTROLLER SIEMENS, 6ED1052-1HB00-0BA5	SEE ITEM 02	NORDSON
EXM312	1	EXPANSION MODULE, PROGRAMMABLE RELAY	6ED1055-1HB00-0BA0	SIEMENS
PRM301, EXM312	.75FT	DIN RAIL	D5PD2-20	CUTLER-HAMMER
D336, D337	2	DIODE	1N4148	INTERNATIONAL RECTIFIER
CR240, CR326, CR331	3	RELAY, 24VDC, SPDT, DIN-RAIL MOUNT	84145041	CROUZET
PWS224	1	POWER SUPPLY, 24VDC, 30 WATT	PS5R-SC24	IDEC
CR240, CR326, CR331	.5FT	DIN RAIL	D5PD2-20	CUTLER-HAMMER
PB228	1	E-STOP BUTTON, TWIST-RELEASE	E22LL2E	CUTLER-HAMMER
SS202	1	SELECTOR, CHROME BEZEL, 2-POSITION	E22X51D	CUTLER-HAMMER
SS306	1	SELECTOR, CHROME BEZEL, 2-POSITION	E22X51A	CUTLER-HAMMER
SSL307, SSL308	2	SELECTOR, CHROME BEZEL, AMBER ILLUMINATED, 2-POSITION	E22S59X95A	CUTLER-HAMMER
PBL314, PBL316	2	PUSHBUTTON, CHROME BEZEL, GREEN ILLUMINATED, RECESSED	E22N3X41A	CUTLER-HAMMER
PB315, PB317	2	PUSHBUTTON, CHROME BEZEL, RED	E22E2B	CUTLER-HAMMER
PB, PBL, SS, SSL	9	REFERENCE DRAWING, DEVICE LABEL SYMBOLS	SEE ITEM 04	NORDSON
CBL-SUPPORT	1	ACORN NUT, 5/16	92994A030	McMASTER-CARR
CBL-SUPPORT	1	HANDLE, THREADED STUD, 5/16	11665A11	McMASTER-CARR
AH340	1	ALARM, PIEZO, CONT. TONE, EXTRA LOUD	XC-09-330-Q	FLOYD BELL
MCP210	1	PROTECTOR, MANUAL MOTOR	A302BN	CUTLER-HAMMER
M325	1	CONTACTOR	CE12BNC310T	CUTLER-HAMMER

OPTIONAL  
OPTIONAL

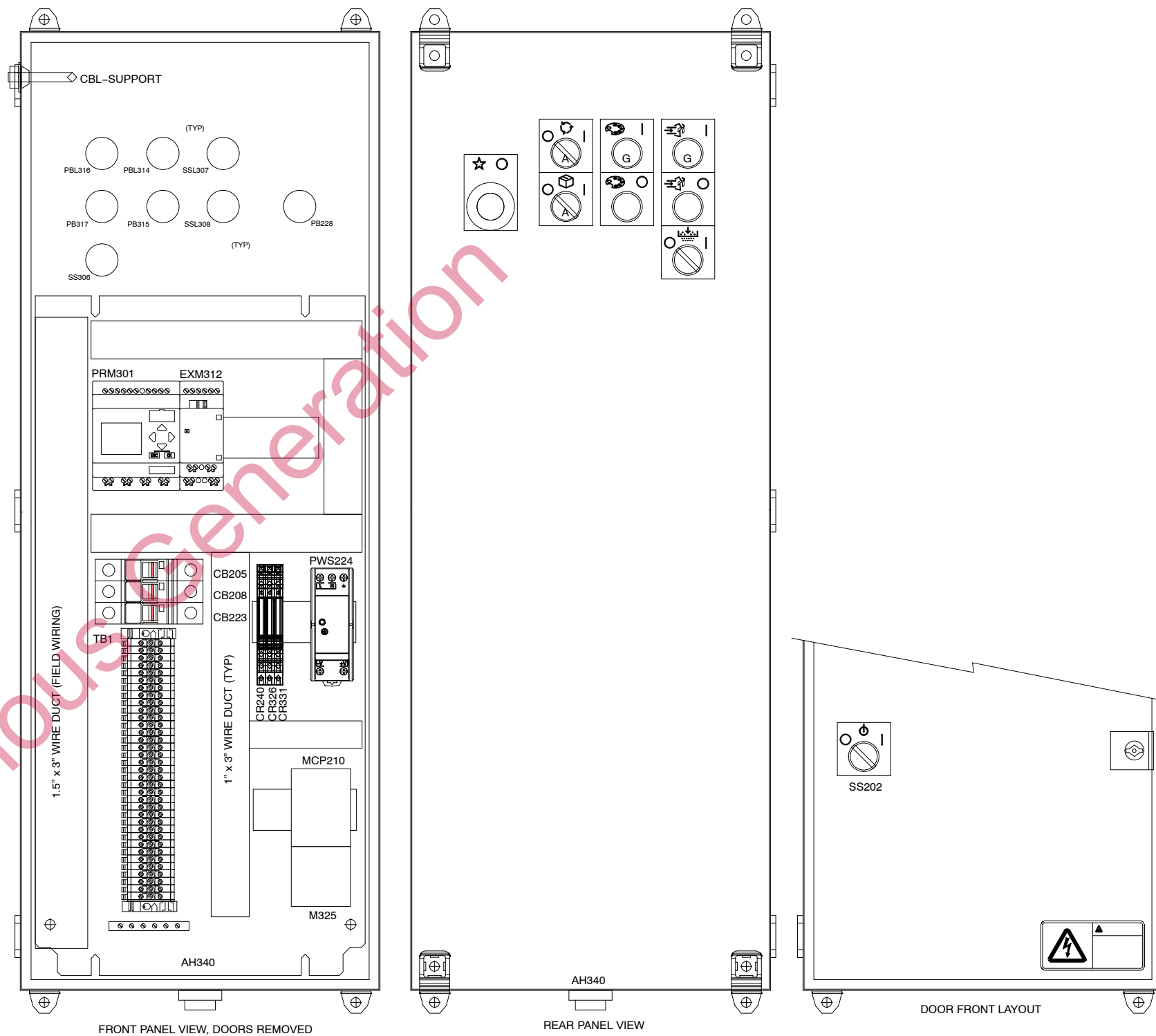
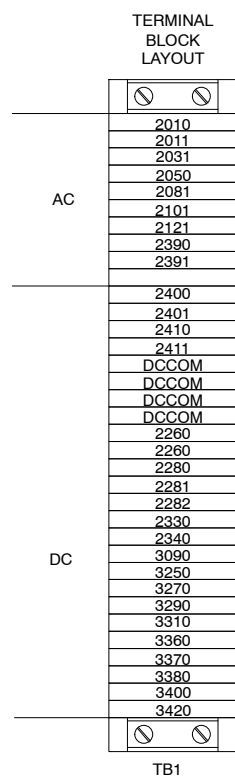

Figure 28 Control Panel (1 of 3)

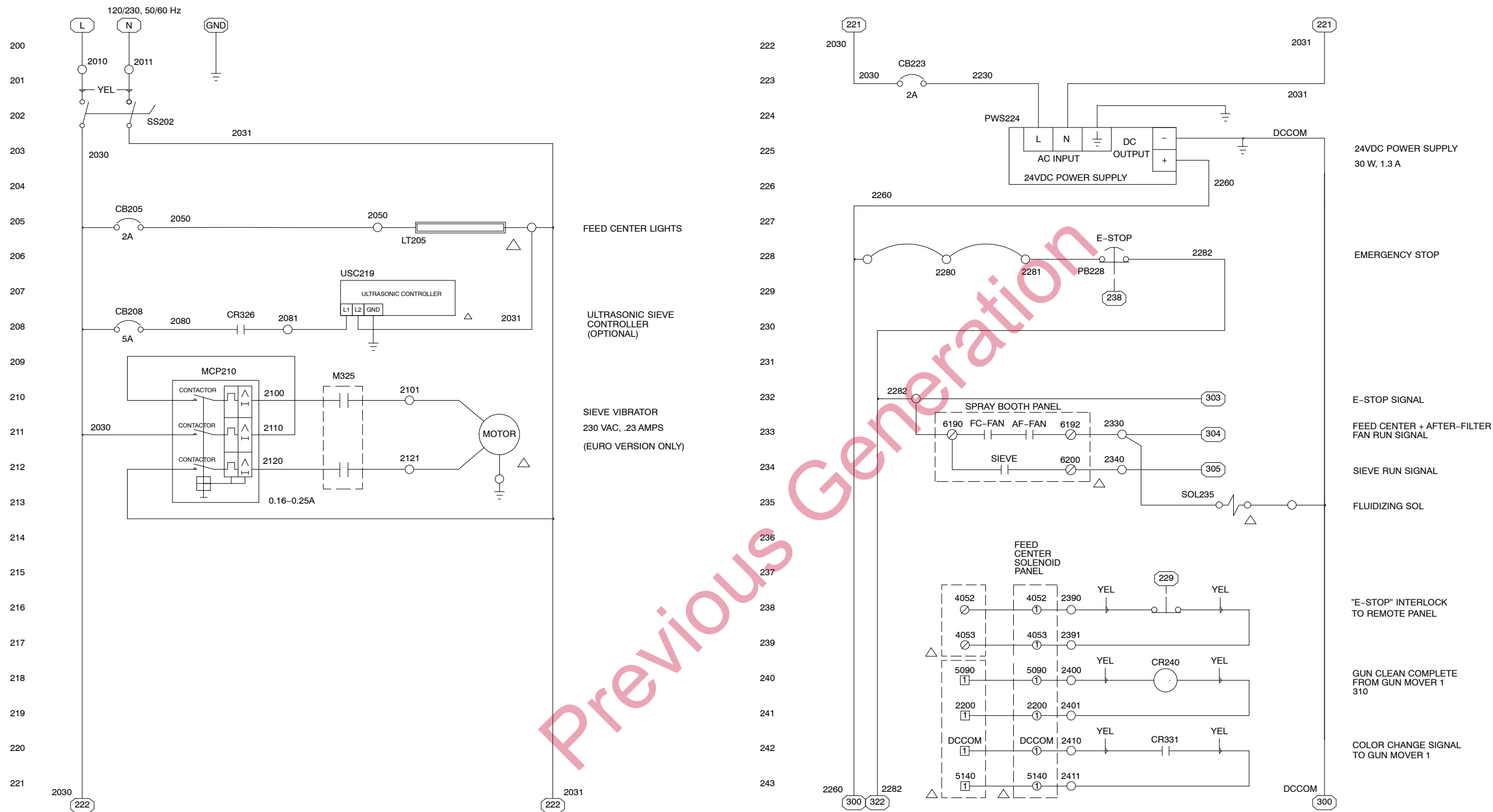

Figure 29 Control Panel (2 of 3)

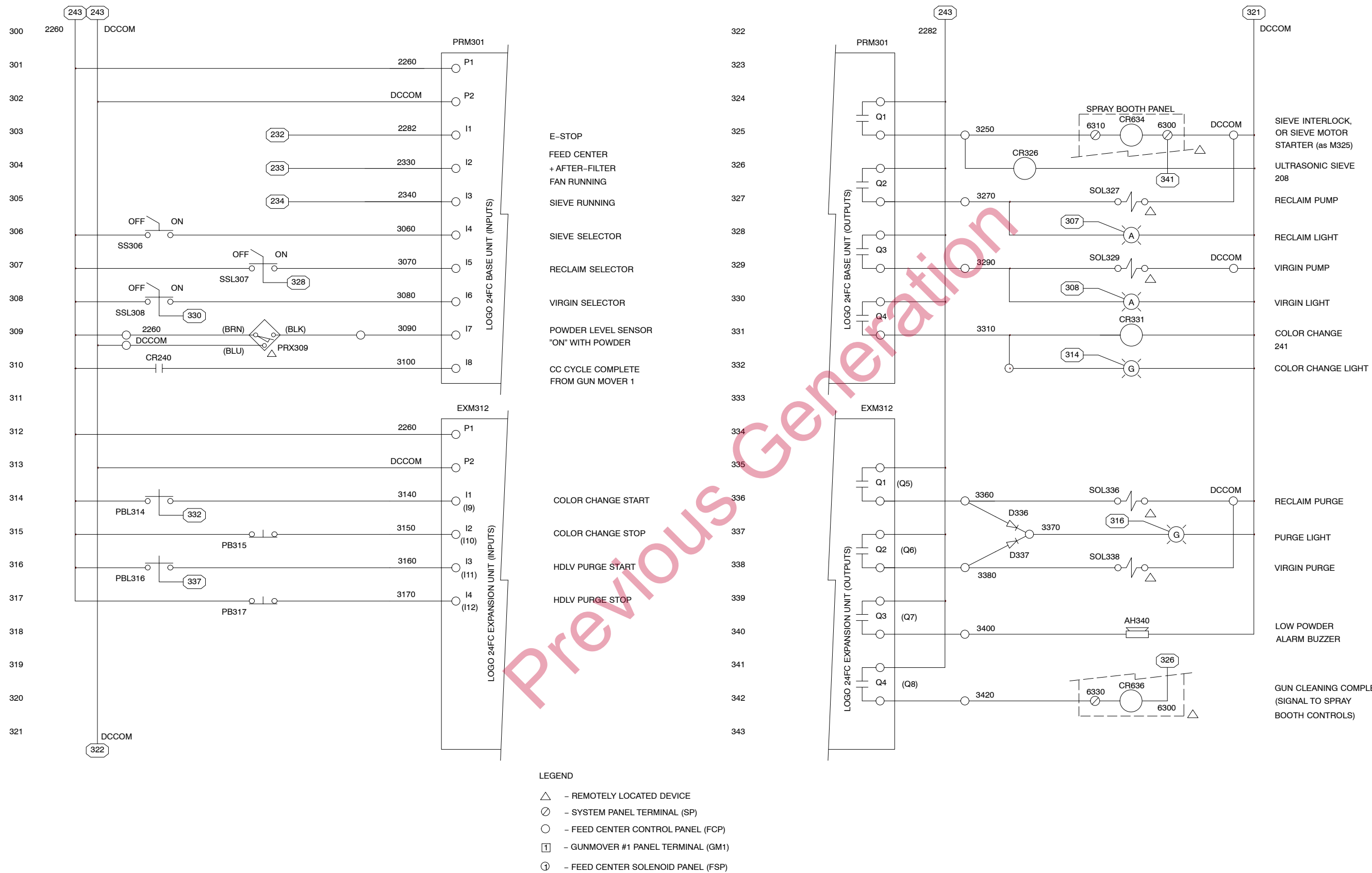
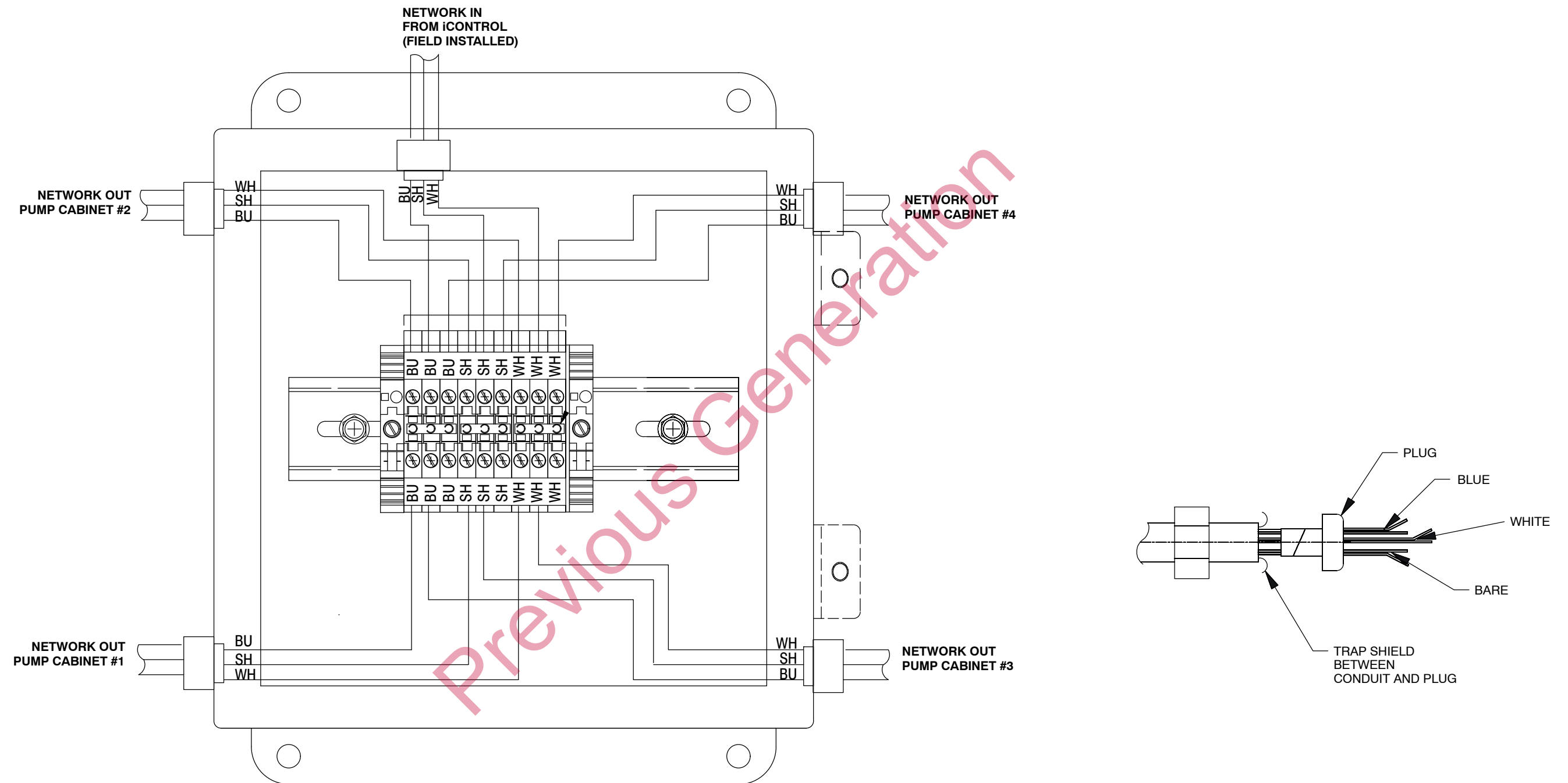

Figure 30 Control Panel (3 of 3)



Reference Drawing 1082780-05

Figure 31 Network Junction Box Schematics and Pump Panel CAN Connections (1 of 2)

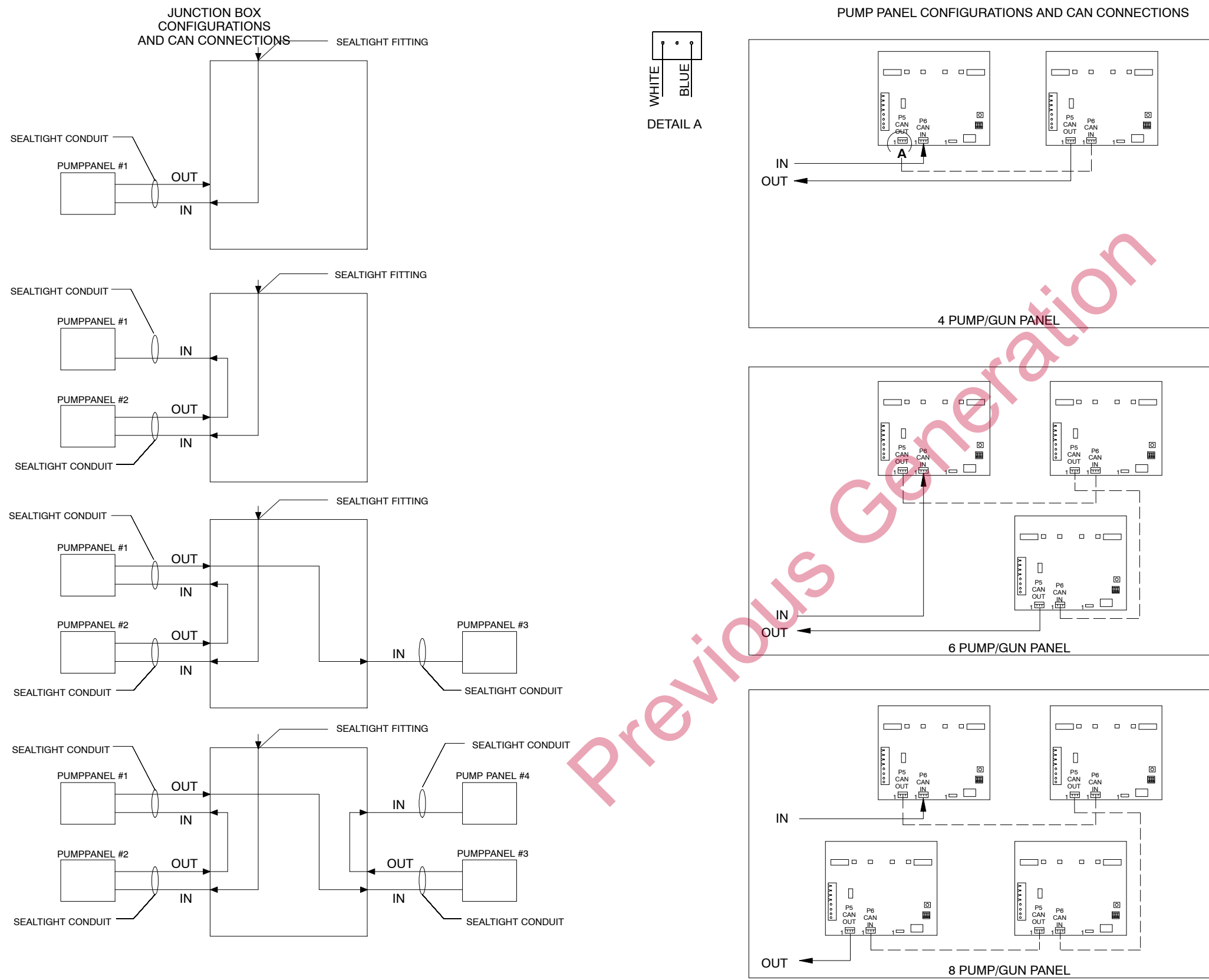

Figure 32 Network Junction Box and Pump Panel CAN Connections (2 of 2)

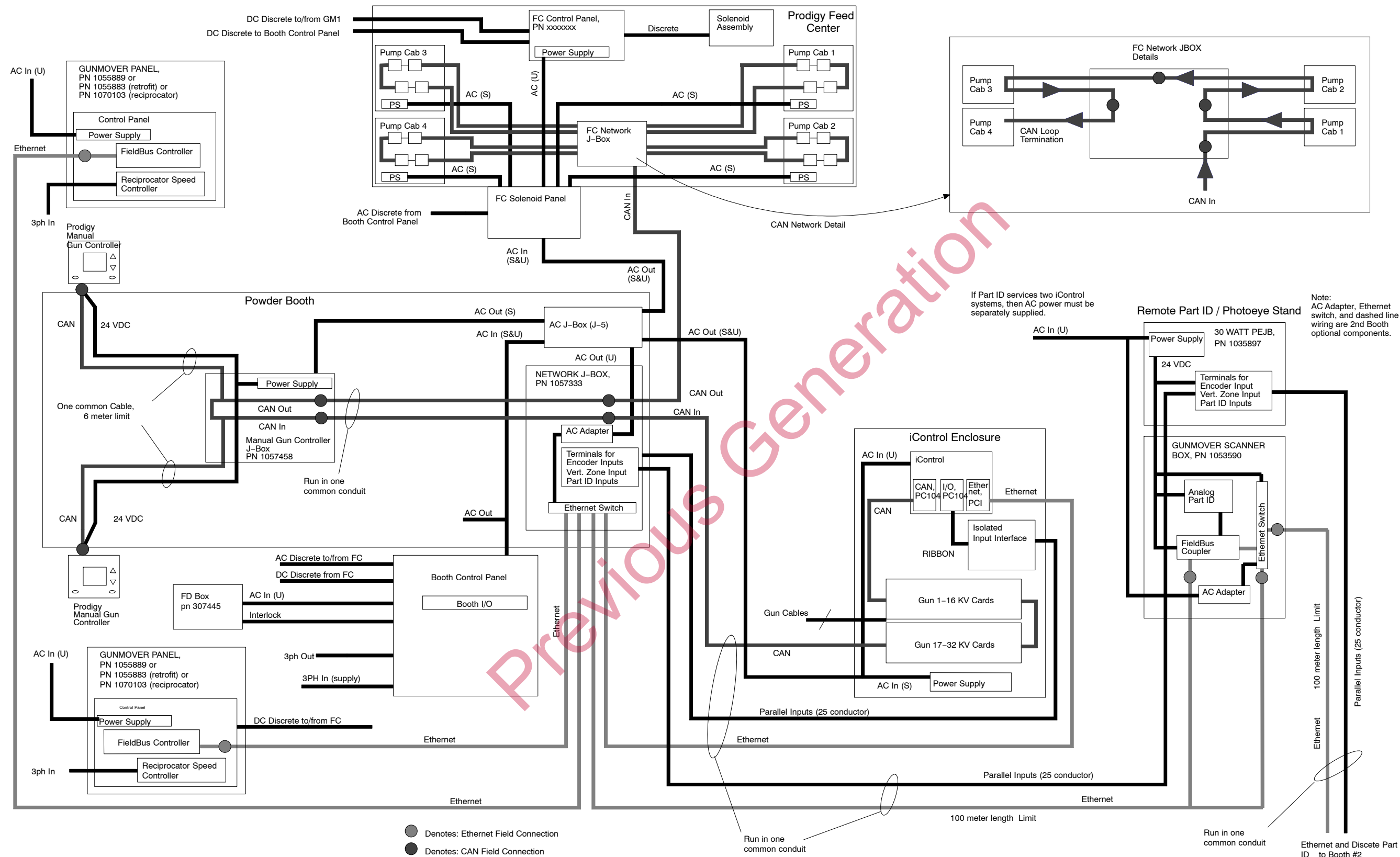

Figure 33 Prodigy Automatic System Architecture