

NORDSON CORPORATION
Powder Coating Systems



Color Change Procedures
ColorMax® Powder Spray System
with Sure-Max® Powder Transfer System



Procedure 1

OPERATOR A



Close the booth doors and move the booth offline (if applicable)

Procedure 2

OPERATOR B

①

Main Menu

Auto



②

Auto Menu

COLOR MENU

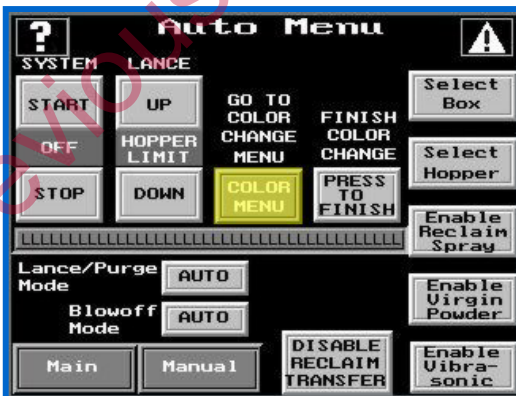

③

Color Change

BLOWOFF

START



Procedure 3

OPERATOR A

①



Disengage coupling

②



Open transfer pan and
blow it out

③



Insert four sponges in
reclaim tube

NOTE: Do not close transfer pan at this time

Procedure 3

OPERATOR B



Color Change

DISABLE
SIEVE

NOTE: If using optional fluidizing hopper (as shown), disconnect fluidizing air line before removing hopper



Unclamp under pan and turn chute toward back wall



Remove powder source from feed center



COLOR CHANGE
CYCLE DONE light
flashes

Procedure 4

OPERATOR B

1



Color Change

GUN
PURGE

START

2



Blow off lance assembly
while lance assembly lowers
onto purge manifold and
guns purge

3



Lance assembly raises when
gun purge is complete

Procedure 5

OPERATOR B

①



Continue blowing off lance
assembly

②



COLOR CHANGE
CYCLE DONE
light flashes

Procedure 6

OPERATOR A

①



Blow off all door sills, then enter booth and blow off ceiling and walls

②



Blow off AeroDecks™

③



Blow out cyclone vertical inlet duct

④



Set AeroDecks™ in operating position and exit booth

Procedure 6

OPERATOR B

1



Color Change

DISABLE RECLAIM TRANSFER

2



Disconnect vacuum hose and pulse air tubing from top of filter assembly

3



Disengage coupling and rotate reclaim receiver to 45° angle

4



Remove filter assembly and filter element

5



Remove four cleaning sponges

6



Rotate receiver and blow out from both ends

Procedure 7

OPERATOR A – PART 1

①



Blow out remaining powder in transfer pan

②



Open cyclone access doors

③



Blow down cyclone interior

Procedure 7

OPERATOR A – PART 2

Spray-to-Reclaim Mode: Follow these steps

Spray-to-Waste Mode: Leave cyclone access doors and transfer pan open

①



Close and latch cyclone access doors

②

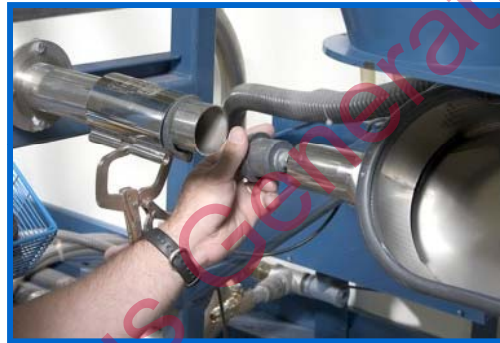

Plug reclaim port

③



Close transfer pan

④



Connect scrap hose to scrap port

Procedure 7

OPERATOR B – PART 1

1



Install new filter element and filter assembly

2



Rotate Sure-Max™ receiver into upright position and install coupling

3



Connect vacuum hose and pulse air tubing

4



Color Change

CLOSE

SUREMAX DOOR

5



Remove sieve deck and sieve screen

Procedure 7

OPERATOR B – PART 2

SIMILAR SHADE COLOR CHANGE STEPS

①



Blow off sieve deck,
sieve screen and
under pan
Assemble sieve and
turn chute toward
lances

②



Install powder
source

DIFFERENT SHADE COLOR CHANGE STEPS

①



Set sieve screen aside
and clean it later. Blow
off sieve deck, under
pan and turn chute
toward lances. Install
appropriate sieve
screen.

②



Turn vacuum diverter
valve to spray-to-waste
position

**Do not install new powder source until end of
Procedure 8**

Procedure 8

OPERATOR A

DIFFERENT SHADE COLOR CHANGE ONLY

If you are performing a similar shade color change, proceed to Procedure 9.



Remove powder feed hose from each spray gun and install other feed hose

Procedure 8

OPERATOR B

DIFFERENT SHADE COLOR CHANGE ONLY

If you are performing a similar shade color change, proceed to Procedure 9.

1



Remove
hose
manifolds
from lance
assembly

2



Blow down
into powder
pumps to
clear away
any
remaining
powder

3



Install
other
hose
manifolds

4



Install new
powder feed
source and
connect
fluidizing air

Procedure 9

OPERATOR B – PART 1

①

Color Change

ENABLE
SIEVE

②

Color Change

AUTO
MENU

③

Auto Menu

PRESS
TO
FINISH

④

Auto Menu

ENABLE
RECLAIM
TRANSFER



Procedure 9

OPERATOR B – PART 2

AUTO MENU SELECTIONS

Specify how the system will operate for this color run.



Select Box

OR

Select Hopper

Starts fluidizing and lowers lance assembly to appropriate level

Enable Reclaim Spray

Spray-to-Reclaim:

Select this button
Oversprayed powder will be reclaimed

Spray-to-Waste:

Do not select this button
Oversprayed powder will be scrapped

Enable Virgin Powder

Turns on Sure-Max bulk feed system

Enable Vibra-sonic

Turns on Vibrasonic sieve screen

NOTE: Spray 0.5 kg (1 lb.) of powder to waste before performing Procedure 10. Amount of time required may vary.

Procedure 10

OPERATOR A

Spray-to-Reclaim Mode Operation Only



Disconnect scrap hose
from scrap port



Install plug onto
scrap port



Remove plug from reclaim
port



Couple reclaim tube to
reclaim port

Procedure 10

OPERATOR B

Spray-to-Reclaim Mode Operation Only



Turn vacuum diverter valve to spray-to-reclaim position

Cyclone Components

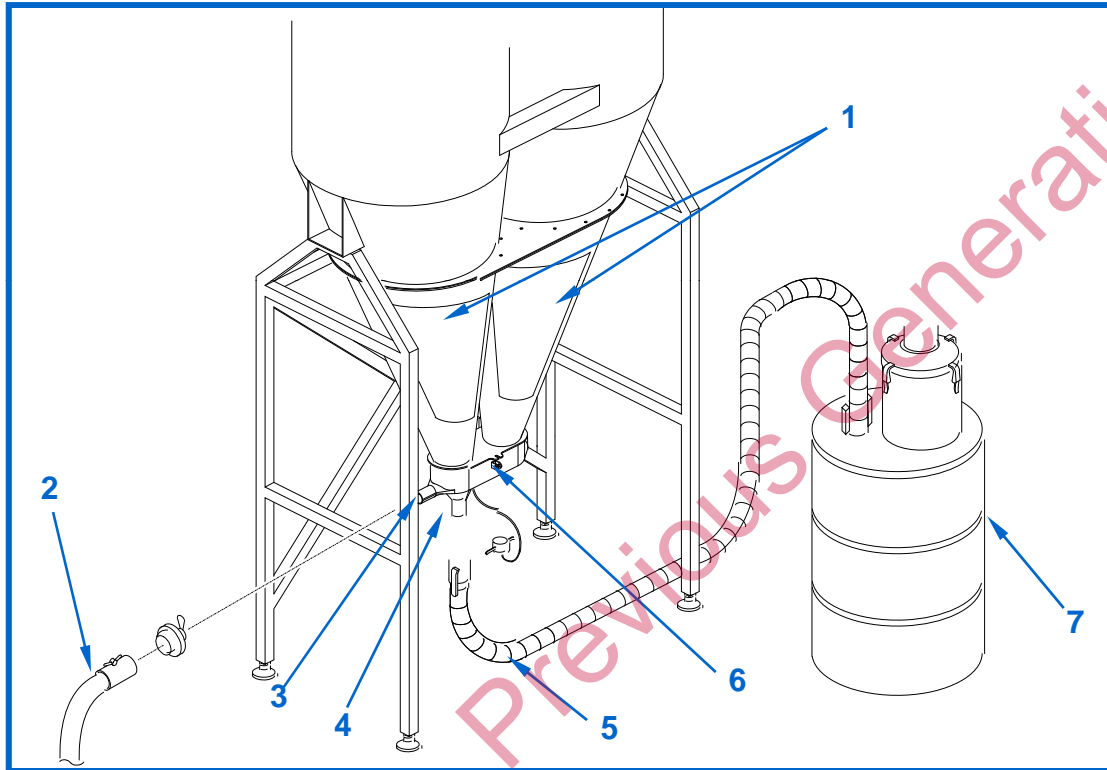

1. Cyclone access doors
2. Reclaim tube
3. Reclaim port
4. Scrap port
5. Scrap hose
6. Transfer pan
7. Scrap drum

Feed Center Components

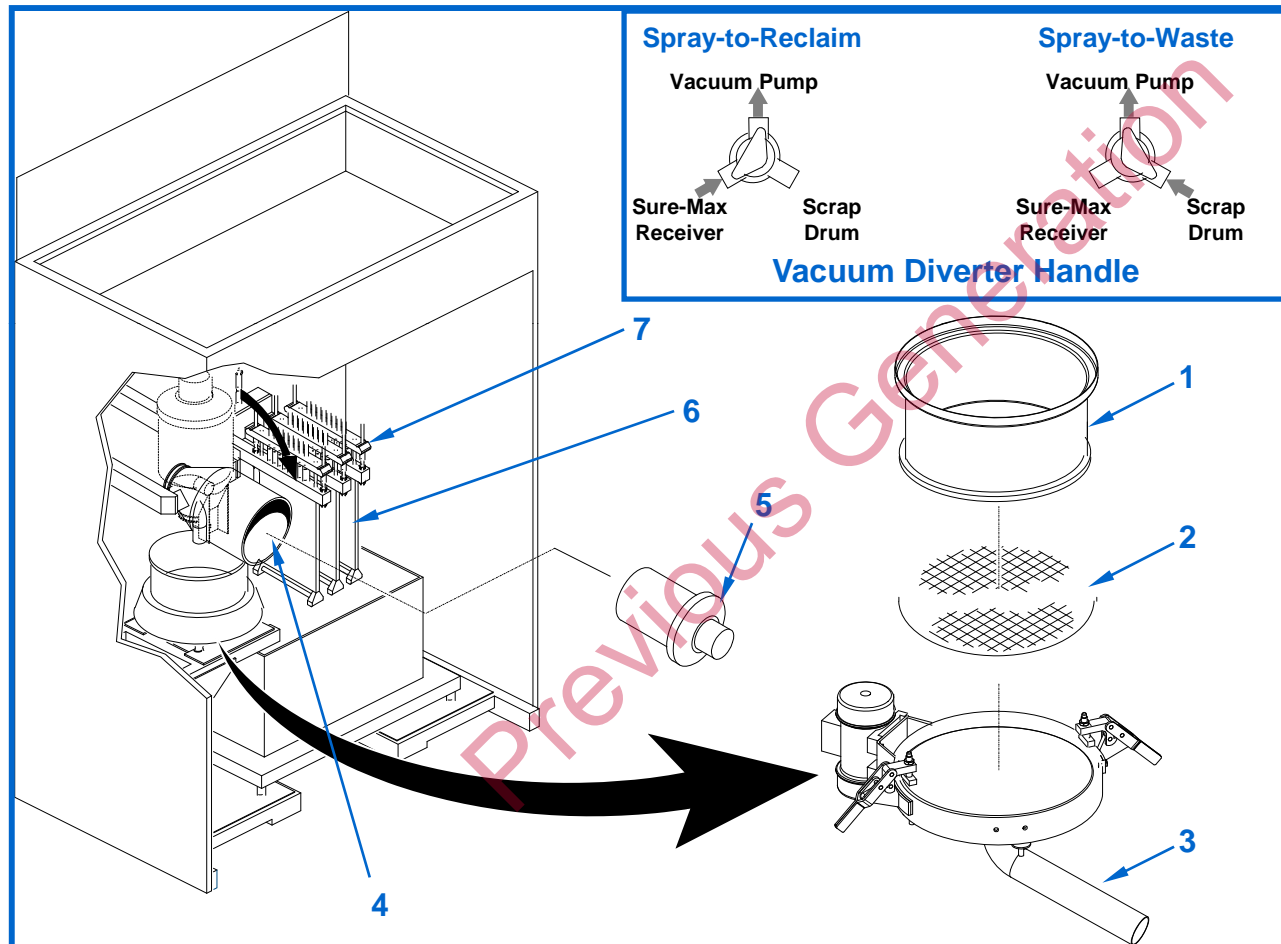

Previous Generation



Nordson Corporation • 300 Nordson Drive • Amherst, Ohio 44001