

Gun Air Manifold for Sure Coat[®] Automatic Guns

used with Sure Coat Modular Gun Control Systems

Introduction

The Sure Coat modular gun control system must have the gun air manifold when it is used with Sure Coat automatic powder spray guns and a powder feed center.

The gun air manifold interlocks the electrode-cleaning gun air to the booth collector fan. This keeps the gun air flowing as long as the fan is on, preventing powder from flowing back into the gun while the powder feed center purges the guns.

Manifold Installation



WARNING: Allow only qualified personnel to perform the following tasks. Follow the safety instructions in this document and all other related documentation.



WARNING: Shut down the system and relieve air pressure before performing the following tasks. Failure to observe this warning may result in equipment damage, personal injury, or death.

1. See Figure 1. Shut down the powder coating system, turn the air supply valve (3) off, and relieve pressure to the modular gun control system.
2. Remove the cover from the pneumatic section cabinet (2).
3. Remove the pipe plug (1) from the main air manifold (4).
4. Wrap PTFE tape around the threads of the supplied pipe nipple (5) and male half of the union (6). Install the nipple into the main air manifold, and the union onto the nipple.

5. See Figure 2. Assemble the pipe clamp assembly (6–11) onto the manifold assembly.
6. Connect the assembly by joining the male (2) and female (5) halves of the union. Tighten the nut on the female half.
7. Secure the pipe clamp assembly to the mounting stud (12) using the hex nut and washers (8, 9, 10).

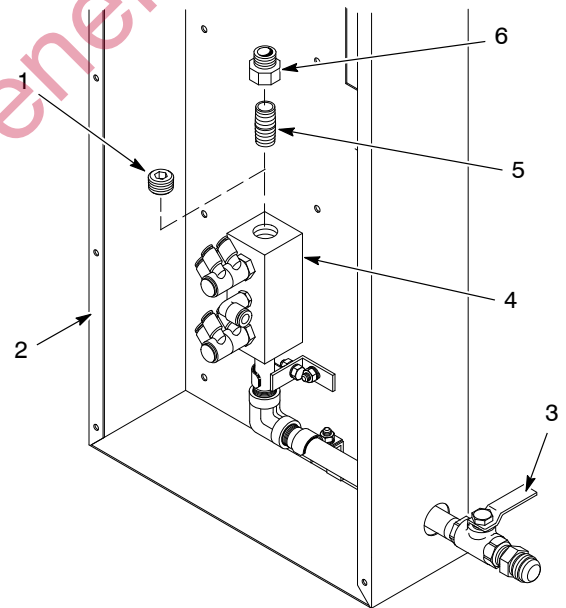

1400945A

Figure 1 Preparing for Manifold Installation

1. Pipe plug
2. Main pneumatic section cabinet
3. Main air shutoff valve
4. Main air manifold
5. Nipple
6. Union (male half)

Tubing Connections

1. See Figure 2. Determine how many guns will be controlled by the modular gun control system. Remove the appropriate number of plugs from the 4-mm fittings (3).
2. Install the 4-mm plugs removed in step 1 into the  (gun air) fittings on the pneumatic modules, if the fittings are not plugged already.
3. Connect clear, 4-mm air tubing from the manifold fittings (3) to the gun air fitting at the back of each gun.
4. Connect the blue, 6-mm air tubing to the valve's 6-mm valve air fitting (4). Connect the other end to the INTERLOCK air fitting on the booth control panel.

Operation Test



WARNING: Do not trigger the guns while performing these steps. Failure to observe this warning may result in a severe shock.

1. Turn on the air supply and check the manifold assembly for leaks. If there are no leaks, install the cover onto the main pneumatic section.
2. Turn on the powder coating system.
3. Disconnect the clear, 4-mm air tubing from the back of one of the guns. If the booth fan is on, you should feel air flowing from the tubing.
4. Reconnect the clear, 4-mm air tubing to the gun. Hold your hand in front of the gun's nozzle to make sure that air is flowing out the front of the control panel.

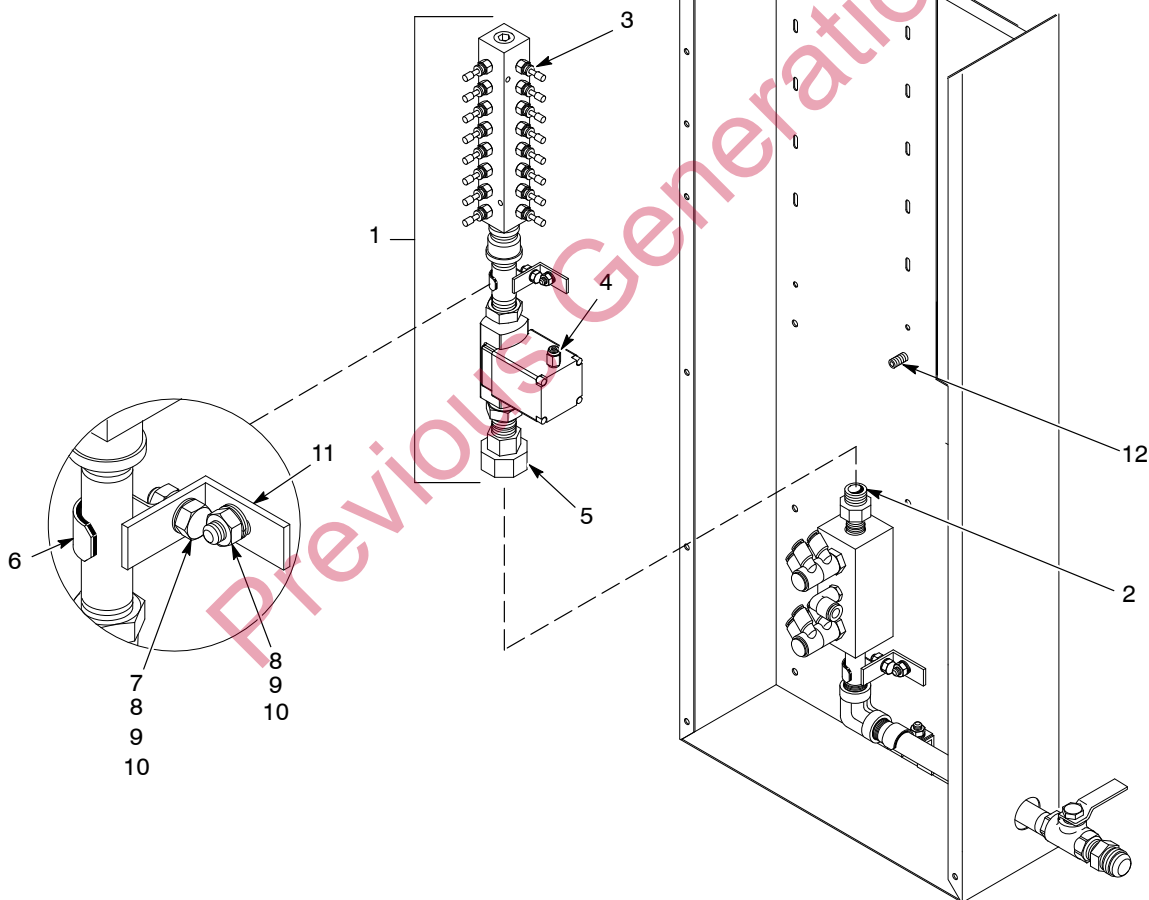

Figure 2 Installing the Manifold

- | | | |
|------------------------------|------------------------|-------------------|
| 1. Gun air manifold assembly | 5. Union (female half) | 9. Lock washer |
| 2. Union (male half) | 6. Clamp | 10. Hex nut |
| 3. 4-mm Plugs and fittings | 7. Screw | 11. Bracket |
| 4. 6-mm Fitting | 8. Flat washer | 12. Mounting stud |

Parts

See Figure 3.

Item	Part	Description	Quantity	Note
—	1038908	KIT, pneumatic module, Sure Coat backflow preventer	1	
1	973422	• PLUG, pipe, socket, flush, $\frac{3}{8}$ in., zinc	1	
2	326139	• PLUG, blanking, 4-mm tubing	16	
3	1033171	• CONNECTOR, orifice, 4 mm x R $\frac{1}{8}$ in., 0.4 mm	16	
4	1038906	• MANIFOLD	1	
5	973553	• NIPPLE, steel, schedule 40, $\frac{3}{8}$ x 1.00 in.	1	
6	973312	• COUPLING, pipe, class 150, $\frac{1}{2}$ x $\frac{3}{8}$ in.	1	
7	973077	• NIPPLE, steel, schedule 40, $\frac{1}{2}$ x 3.00-in. long	1	
8	973360	• BUSHING, reducer, $\frac{3}{4}$ x $\frac{1}{2}$ in., steel, plain	2	
9	303132	• VALVE, $\frac{3}{4}$ -in. input/output, air operated	1	
10	973076	• NIPPLE, steel, schedule 40, $\frac{1}{2}$ x 1.12 in.	2	
11	973006	• UNION, pipe, class 150, $\frac{1}{2}$ in., galvanized	1	
12	973483	• PLUG, pipe, socket, $\frac{1}{8}$ in., steel	1	
13	972141	• CONNECTOR, male, 6-mm tube x $\frac{1}{8}$ -in. universal	1	
14	982129	• SCREW, hex, machine, M6 x 16, zinc	1	
15	983410	• WASHER, flat, M, narrow, M6, steel, zinc	3	
16	983409	• WASHER, lock, M, split, M6, steel, zinc	2	
17	984703	• NUT, hex, M6, steel, zinc	2	
18	183467	• BRACKET, L-shaped	1	
19	334772	• GASKET, bulk, 0.25 x 0.50 in., with PSA	AR	
20	163435	• CLAMP, $\frac{3}{4}$ -in. conduit, one hole	1	
NS	900586	• TUBING, polyurethane, 6-mm OD x 4-mm ID, blue	25 ft	
AR: As Required				
NS: Not Shown				

Parts *(contd)*

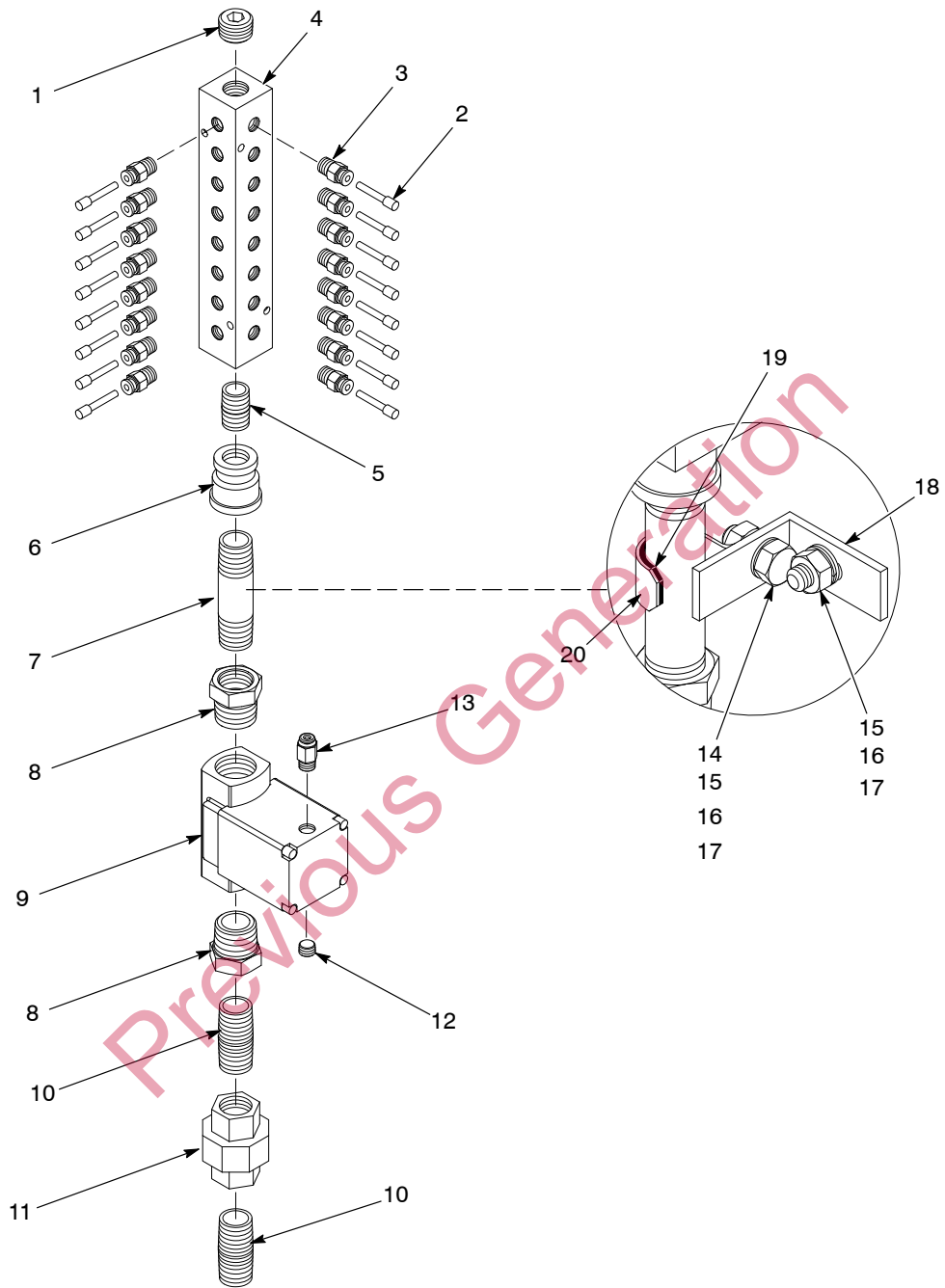

Figure 3 Gun Air Manifold Parts

Issued 2/03

Original copyright date 2003. Nordson, the Nordson logo, and Sure Coat are registered trademarks of Nordson Corporation.