

# **AeroCharge<sup>®</sup> Electronic Manual Powder Spray Gun**

Customer Product Manual  
Part 1023247B  
Issued 7/02

Previous Generation



NORDSON CORPORATION • AMHERST, OHIO • USA



Nordson Corporation welcomes requests for information, comments, and inquiries about its products. General information about Nordson can be found on the Internet using the following address: <http://www.nordson.com>.

Address all correspondence to:

Nordson Corporation  
Attn: Customer Service  
555 Jackson Street  
Amherst, OH 44001

#### **Notice**

This is a Nordson Corporation publication which is protected by copyright. Original copyright date 2002. No part of this document may be photocopied, reproduced, or translated to another language without the prior written consent of Nordson Corporation. The information contained in this publication is subject to change without notice.

© 2002 All rights reserved.

#### **Trademarks**

AccuJet, AeroCharge, AquaGuard, Asymtek, Automove, Autotech, Baitgun, Blue Box, CF, CanWorks, Century, Clean Coat, CleanSleeve, CleanSpray, Control Coat, Cross-Cut, Cyclo-Kinetic, Dispensejet, DispenseMate, Durafiber, Durasystem, Easy Coat, Easymove Plus, Econo-Coat, EFD, ETI, Excel 2000, Flex-O-Coat, FlexiCoat, Flexi-Spray, Flow Sentry, Fluidmove, FoamMelt, FoamMix, Helix, Horizon, Hot Shot, Isocoil, Isocore, Iso-Flo, JR, KB30, Kinetix, Little Squirt, Magnastatic, MEG, Meltex, Microcoat, MicroSet, Millennium, Mini Squirt, Moist-Cure, Mountaingate, MultiScan, Nordson, OmniScan, OptiMix, Package of Values, Patternview, PluraFoam, Porous Coat, PowderGrid, Powderware, Prism, Pro-Flo, ProLink, Pro-Meter, Pro-Stream, PRX, RBX, Rhino, S. design stylized, Saturn, SC5, Seal Sentry, Select Charge, Select Coat, Select Cure, Slautterback, Smart-Coat, Solder Plus, Spectrum, Spray Squirt, Spraymelt, Super Squirt, Sure Coat, Tela-Therm, Trends, Tribomatic, UniScan, UpTime, Veritec, Versa-Coat, Versa-Screen, Versa-Spray, Walcom, Watermark, and When you expect more.  
are registered trademarks of Nordson Corporation.

ATS, Auto-Flo, AutoScan, BetterBook, Chameleon, CanNeck, Check Mate, Colormax, Control Weave, Controlled Fiberization, CoolWave, CPX, Dura-Coat, Dry Cure, E-Nordson, EasyClean, Eclipse, Equi=Bead, Fill Sentry, Fillmaster, Gluie, Heli-flow, Ink-Dot, Iso-Flex, Lacquer Cure, Maxima, MicroFin, MicroMax, Minimeter, Multifil, Origin, PermaFlo, PluraMix, Powder Pilot, Powercure, Primarc, Process Sentry, PurTech, Pulse Spray, Ready Coat, Select Series, Sensomatic, Shaftshield, SheetAire, Spectral, Spectronic, Speedking, Spray Works, Summit, Sure Brand, Sure Clean, Sure Max, Swirl Coat, Tempus, Tracking Plus, Trade Plus, Universal, Vista, Web Cure, and 2 Rings (Design)  
are trademarks of Nordson Corporation.

# Table of Contents

<b>Safety</b> .....	<b>1</b>
Qualified Personnel .....	1
Intended Use .....	1
Regulations and Approvals .....	1
Personal Safety .....	2
Fire Safety .....	2
Grounding .....	3
Action in the Event of a Malfunction .....	3
Disposal .....	3
<b>Description</b> .....	<b>4</b>
Compatible Control Units .....	5
Nozzles .....	5
Extensions .....	5
Powder Coatings .....	5
Theory of Operation .....	6
<b>Installation</b> .....	<b>7</b>
Powder Pump Selection .....	7
Connections .....	8
Powder Feed Hose .....	8
Gun Cable .....	8
Air Tubing .....	8
Optional Barrel Extension Kit .....	10
Optional Long Gun Extension Kit .....	12
Removing the Existing Powder Inlet Tube and Barrel .....	12
Installing the Extended Powder Inlet Tube and Barrel .....	12
<b>Operation</b> .....	<b>14</b>
Startup .....	14
Spraying Powder .....	14
Shutdown .....	15
<b>Daily Maintenance</b> .....	<b>15</b>
Cleaning .....	15
Charge Sleeve Rotation .....	16
<b>Troubleshooting</b> .....	<b>18</b>
<b>Repair</b> .....	<b>21</b>
Powder Inlet Tube Replacement .....	21
Powder Inlet Sleeve Replacement .....	22
Cable Replacement .....	23
Removal .....	23
Installation .....	23
<b>Parts</b> .....	<b>25</b>
Using the Illustrated Parts List .....	25
AeroCharge Electronic Manual Powder Spray Gun Parts .....	26
Extension Kits .....	28
Barrel Extension Kit .....	28
Long Gun Extension Kit .....	29
Nozzles and Deflectors .....	30
Recommended Spare Parts .....	30

Previous Generation

# AeroCharge Electronic Manual Powder Spray Gun

## Safety

Read and follow these safety instructions. Task- and equipment-specific warnings, cautions, and instructions are included in equipment documentation where appropriate.

Make sure all equipment documentation, including these instructions, is accessible to all persons operating or servicing equipment.

## Qualified Personnel

Equipment owners are responsible for making sure that Nordson equipment is installed, operated, and serviced by qualified personnel. Qualified personnel are those employees or contractors who are trained to safely perform their assigned tasks. They are familiar with all relevant safety rules and regulations and are physically capable of performing their assigned tasks.

## Intended Use

Use of Nordson equipment in ways other than those described in the documentation supplied with the equipment may result in injury to persons or damage to property.

Some examples of unintended use of equipment include

- using incompatible materials
- making unauthorized modifications
- removing or bypassing safety guards or interlocks
- using incompatible or damaged parts
- using unapproved auxiliary equipment
- operating equipment in excess of maximum ratings

## Regulations and Approvals

Make sure all equipment is rated and approved for the environment in which it is used. Any approvals obtained for Nordson equipment will be voided if instructions for installation, operation, and service are not followed.

All phases of equipment installation must comply with all federal, state, and local codes.

## **Personal Safety**

To prevent injury follow these instructions.

- Do not operate or service equipment unless you are qualified.
- Do not operate equipment unless safety guards, doors, or covers are intact and automatic interlocks are operating properly. Do not bypass or disarm any safety devices.
- Keep clear of moving equipment. Before adjusting or servicing any moving equipment, shut off the power supply and wait until the equipment comes to a complete stop. Lock out power and secure the equipment to prevent unexpected movement.
- Relieve (bleed off) hydraulic and pneumatic pressure before adjusting or servicing pressurized systems or components. Disconnect, lock out, and tag switches before servicing electrical equipment.
- Obtain and read Material Safety Data Sheets (MSDS) for all materials used. Follow the manufacturer's instructions for safe handling and use of materials, and use recommended personal protection devices.
- To prevent injury, be aware of less-obvious dangers in the workplace that often cannot be completely eliminated, such as hot surfaces, sharp edges, energized electrical circuits, and moving parts that cannot be enclosed or otherwise guarded for practical reasons.

## **Fire Safety**

To avoid a fire or explosion, follow these instructions.

- Do not smoke, weld, grind, or use open flames where flammable materials are being used or stored.
- Provide adequate ventilation to prevent dangerous concentrations of volatile materials or vapors. Refer to local codes or your material MSDS for guidance.
- Do not disconnect live electrical circuits while working with flammable materials. Shut off power at a disconnect switch first to prevent sparking.
- Know where emergency stop buttons, shutoff valves, and fire extinguishers are located. If a fire starts in a spray booth, immediately shut off the spray system and exhaust fans.
- Clean, maintain, test, and repair equipment according to the instructions in your equipment documentation.
- Use only replacement parts that are designed for use with original equipment. Contact your Nordson representative for parts information and advice.

## Grounding



**WARNING:** Operating faulty electrostatic equipment is hazardous and can cause electrocution, fire, or explosion. Make resistance checks part of your periodic maintenance program. If you receive even a slight electrical shock or notice static sparking or arcing, shut down all electrical or electrostatic equipment immediately. Do not restart the equipment until the problem has been identified and corrected.

All work conducted inside the spray booth or within 1 m (3 ft) of booth openings is considered within a Class 2, Division 1 or 2 Hazardous location and must comply with NFPA 33, NFPA 70 (NEC articles 500, 502, and 516), and NFPA 77, latest conditions.

- All electrically conductive objects in the spray areas shall be electrically connected to ground with a resistance of not more than 1 megohm as measured with an instrument that applies at least 500 volts to the circuit being evaluated.
- Equipment to be grounded includes, but is not limited to, the floor of the spray area, operator platforms, hoppers, photoeye supports, and blow-off nozzles. Personnel working in the spray area must be grounded.
- There is a possible ignition potential from the charged human body. Personnel standing on a painted surface, such as an operator platform, or wearing non-conductive shoes, are not grounded. Personnel must wear shoes with conductive soles or use a ground strap to maintain a connection to ground when working with or around electrostatic equipment.
- Operators must maintain skin-to-handle contact between their hand and the gun handle to prevent shocks while operating manual electrostatic spray guns. If gloves must be worn, cut away the palm or fingers, wear electrically conductive gloves, or wear a grounding strap connected to the gun handle or other true earth ground.
- Shut off electrostatic power supplies and ground gun electrodes before making adjustments or cleaning powder spray guns.
- Connect all disconnected equipment, ground cables, and wires after servicing equipment.

## Action in the Event of a Malfunction

If a system or any equipment in a system malfunctions, shut off the system immediately and perform the following steps:

- Disconnect and lock out electrical power. Close pneumatic shutoff valves and relieve pressures.
- Identify the reason for the malfunction and correct it before restarting the equipment.

## Disposal

Dispose of equipment and materials used in operation and servicing according to local codes.

## Description

See Figure 1.

The AeroCharge electronic manual powder spray gun uses air jets to electrostatically charge powder coatings. As compressed air moves through the spray gun, the air is forced through air jet holes in a powder inlet sleeve, electrostatically charging the powder coating.

The AeroCharge manual powder spray gun is ideal for close-in coating of corners, and is excellent for recoating and touch-up work.

**NOTE:** Typical powder flow rate is approximately 11.3–13.6 kg (25–30 lb) per hour.

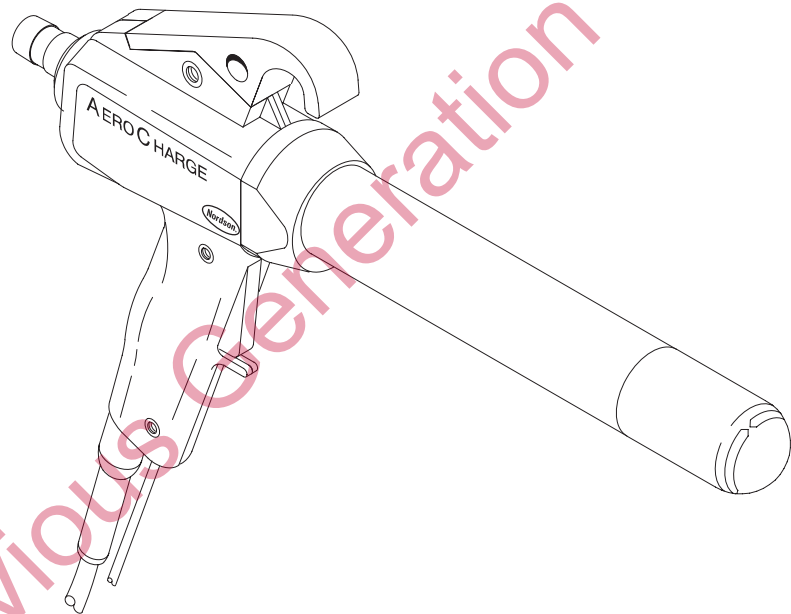

1400448A

Figure 1 AeroCharge Electronic Manual Powder Spray Gun

## Compatible Control Units

The AeroCharge electronic manual powder spray gun may be used with any of the following manual powder spray gun control units:

- Tribomatic
- Versa-Spray II
- Sure Coat

**NOTE:** The AeroCharge electronic manual spray gun cable and gun jet air tubing connect directly to Tribomatic and Versa-Spray II control units. Use the cable adapter and 6 mm to 8 mm reducer fitting included with the spray gun to connect the AeroCharge spray gun to a Sure Coat control unit.

## Nozzles

A variety of nozzles and deflectors are shipped with the spray gun. Your Nordson representative can help you decide which nozzle is best for your application.

## Extensions

Two optional kits are available to extend the length of the spray gun.

Refer to *Installation* for the procedures on how to install the kits.

Refer to *Extension Kits* in *Parts* for ordering information.

**Barrel Extension Kit:** This kit allows you to extend the barrel length of the spray gun by 100 mm (four in.). The kit includes a barrel extension, a powder inlet tube, and O-rings. Multiple barrel extension kits can be added onto the spray gun.

**Long Gun Extension Kit:** This kit allows you to exchange the spray gun's existing barrel with a longer, 250-mm (10-in.) barrel. This increases the length of the spray gun by 100 mm (four in.). The kit includes a barrel, a powder inlet tube and O-rings. To further extend the spray gun you may add one or multiple barrel extension kits to a long spray gun.

## Powder Coatings

This spray gun can be used with a wide variety of powder coatings, but was not meant to be used with pure epoxies.

Some powder coatings may need to be tested for compatibility with the AeroCharge spray gun. Contact your powder supplier or Nordson representative for information about compatibility testing.

## Theory of Operation

See Figure 2.

Flow rate air pumps powder out of the powder source and forces it through the feed hose to the spray gun. The powder flows through the powder inlet tube in the spray gun.

Compressed air enters the spray gun through a 6-mm tube in the handle and surrounds the powder inlet tube. The compressed air is then forced through air jet holes in the powder inlet sleeve, electrostatically charging the powder coating as it enters the charge sleeve.

The powder coating continues through the spray gun barrel and out the spray nozzle, where the charged powder is attracted to the grounded part to be coated.

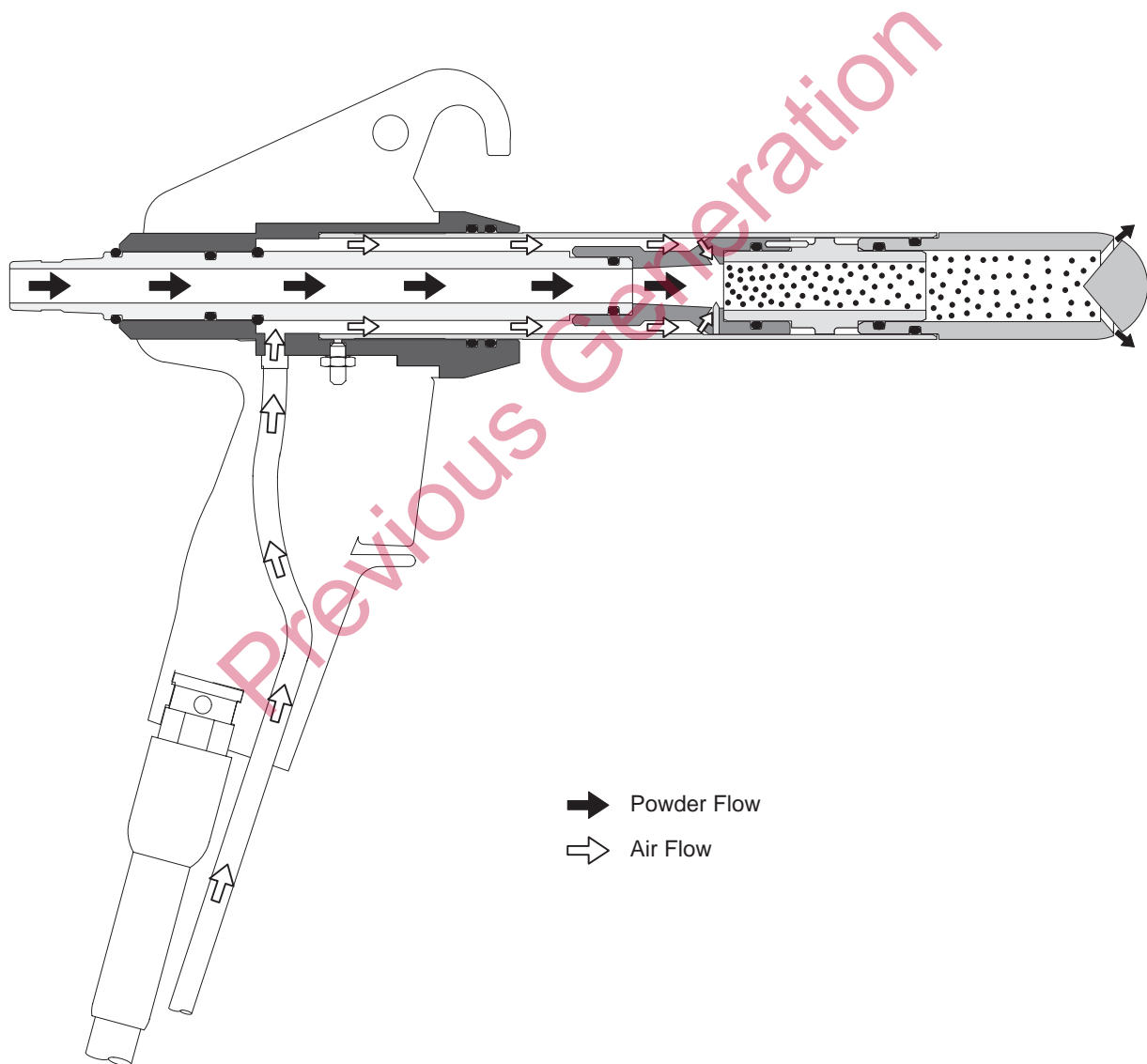

Figure 2 Theory of Operation

140049A

## Installation



**WARNING:** Allow only qualified personnel to perform the following tasks. Follow the safety instructions in this document and all other related documentation.

### *Powder Pump Selection*

The spray gun may be used with either a 6- or 8-mm Tribomatic powder pump. The size of pump that you need depends on what type of control unit you have.

Refer to the following chart to determine which pump to use with your control unit.

Control Unit	Tribomatic Pump Size
Sure Coat	8 mm
Tribomatic	6 mm
Versa-Spray II	6 mm

**NOTE:** Install the powder pump as described in the instructions included with the pump.

Previous Generation

## Connections

Refer to your control unit and pump manuals for connections that are not explained in the following paragraphs.

### Powder Feed Hose

See Figure 3.

**NOTE:** For best results, the powder feed hose must be 6–7.5 m (20–25 ft) long. The powder flow from the spray gun will pulse if the feed hose is shorter than 6 m (20 ft).

Connect a  $\frac{3}{8}$ -in. diameter feed hose (E) (customer supplied) from a Tribomatic powder pump (D) to the spray gun's powder inlet (17). Secure the feed hose at both ends using hose clamps.

### Gun Cable

See Figure 3.

**NOTE:** If you are connecting the spray gun to a Sure Coat control unit, use the cable adapter that was shipped with the spray gun.

Connect the gun cable (28) to the GUN OUTPUT receptacle on the manual powder spray gun control unit (A). Tighten the cable's lock nut to secure the cable to the receptacle.

Refer to your control unit manual for further installation instructions.

### Air Tubing

See Figure 3.

Air Tubing	Procedure
<b>Flow Rate</b>	Connect black flow rate air tubing (C) from the pump (D) to the control unit (A).
<b>Gun Jet</b>	
Tribomatic and Versa-Spray II Control Units	Connect the blue gun jet air tubing (32) (in the spray gun handle) to the atomizing air fitting on the back of the control unit (A).
Sure Coat Control Units	<ol style="list-style-type: none"> <li>1. Install the 8 mm to 6 mm reducer fitting (B) (shipped with the spray gun) into the atomizing air fitting on the control unit.</li> <li>2. Connect the blue gun jet air tubing (32) (in the spray gun handle) to the reducer fitting.</li> </ol>

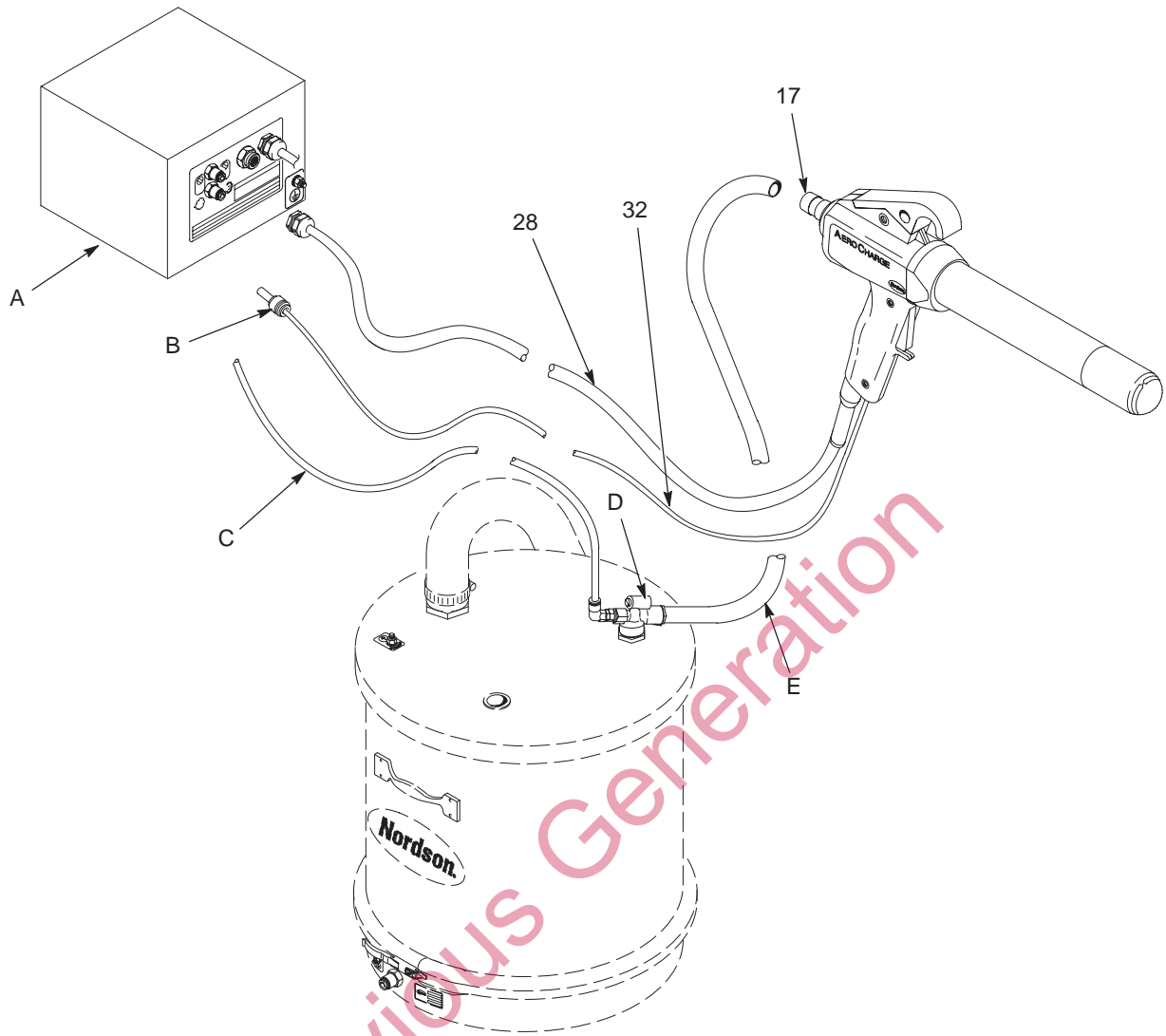

1400450A

Figure 3 Spray Gun Connections

- |   |                            |                                   |
|---|----------------------------|-----------------------------------|
| A. Manual spray gun control unit                    | D. Tribomatic powder pump  | 28. Gun cable                     |
| B. 8-mm to 6-mm Reducer fitting<br>(Sure Coat only) | E. Powder feed hose        | 32. Blue, 6-mm gun jet air tubing |
| C. Black flow rate air tubing                       | 17. Spray gun powder inlet |                                   |

*Note:* Typical control unit, pump, and hopper shown. Your system may appear slightly different.

## Optional Barrel Extension Kit

Install this kit to extend the length of the existing spray gun barrel by 100 mm (four in.).

**NOTE:** Disregard this procedure if you did not order an optional barrel extension kit.

See Figure 4.

1. Twist and pull the nozzle (4) off the spray gun. The nozzle, charge sleeve (8), and powder inlet sleeve (9) should come out of the spray gun.

**NOTE:** If the charge sleeve does not come out with the other pieces, twist and remove the barrel (11) from the spray gun to expose and remove the charge sleeve. Install the barrel onto the spray gun.

**NOTE:** You do not have to perform steps 2 and 3 if you are installing the optional barrel extension kit onto a new spray gun.

2. Inspect all O-rings and replace them as necessary.
3. Inspect the charge sleeve for impact fusion or wear. Refer to *Charge Sleeve Rotation in Daily Maintenance* for information on how to rotate, clean, and/or replace the charge sleeve.
4. Insert the powder inlet tube extension (A) into the barrel of the spray gun and onto the existing powder inlet tube (12). The extension should sit in the same place where the powder inlet sleeve was removed.
5. Install the barrel extension (B) onto the end of the existing barrel.

**NOTE:** If more than one extension kit is used, repeat steps 4 and 5 to install the additional kits. The powder inlet sleeve, charge sleeve, and nozzle must be the last pieces installed on the spray gun.

6. Insert the powder inlet sleeve, charge sleeve, and nozzle into the barrel extension and push them onto the powder inlet tube extension.

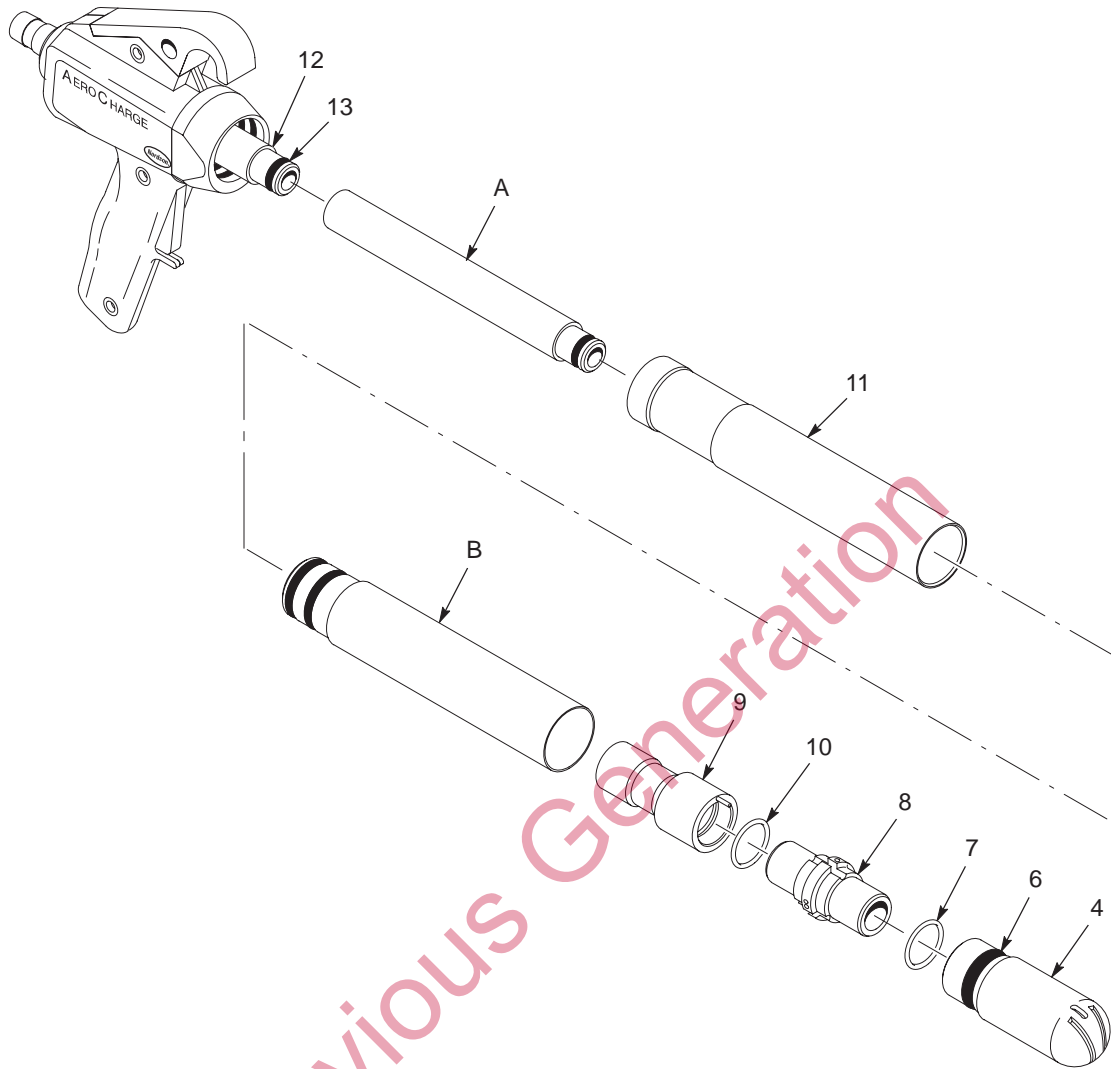

1400265B

Figure 4 Optional Barrel Extension Kit Installation

- |                         |                        |                       |
|-------------------------|------------------------|-----------------------|
| A. Inlet tube extension | 7. O-ring              | 11. Barrel            |
| B. Barrel extension     | 8. Charge sleeve       | 12. Powder inlet tube |
| 4. Nozzle               | 9. Powder inlet sleeve | 13. O-ring            |
| 6. O-ring               | 10. O-ring             |                       |

Note: Item numbers correspond to those in Figures 8 and 9.

## ***Optional Long Gun Extension Kit***

Install this kit to exchange the existing spray gun barrel with a 250-mm (10-in.) barrel. This kit will increase the length of the spray gun by 100 mm (four in.).

**NOTE:** Disregard these procedures if you did not order an optional long gun extension kit.

### **Removing the Existing Powder Inlet Tube and Barrel**

See Figure 5.

1. Remove the O-ring (14) from the back of the powder inlet tube (12).
2. Pull the nozzle (4), charge sleeve (8), and powder inlet sleeve (9) from the powder inlet tube and barrel (11).
3. Twist and pull the barrel off the spray gun.

**NOTE:** You do not have to perform steps 4 and 5 if you are installing the optional long gun extension kit onto a new spray gun.

4. Inspect all O-rings and replace them as necessary.
5. Inspect the charge sleeve for impact fusion or wear. Refer to *Charge Sleeve Rotation* in *Daily Maintenance* for information on how to rotate, clean, and/or replace the charge sleeve.
6. Push the powder inlet tube out the front of the spray gun.

### **Installing the Extended Powder Inlet Tube and Barrel**

See Figure 5.

1. Insert the new extended powder inlet tube (12) from the kit through the front of the spray gun.
2. Install the O-ring (14) on to the end of the new powder inlet tube.
3. Insert the new extended barrel (11) from the kit onto the spray gun.
4. Insert the powder inlet sleeve (9), charge sleeve (8), and nozzle (4) into the new, extended barrel.

**NOTE:** To further extend the length of the spray gun, one or multiple barrel extension kits may be added to the spray gun. Refer to *Optional Barrel Extension Kit* for installation procedures.

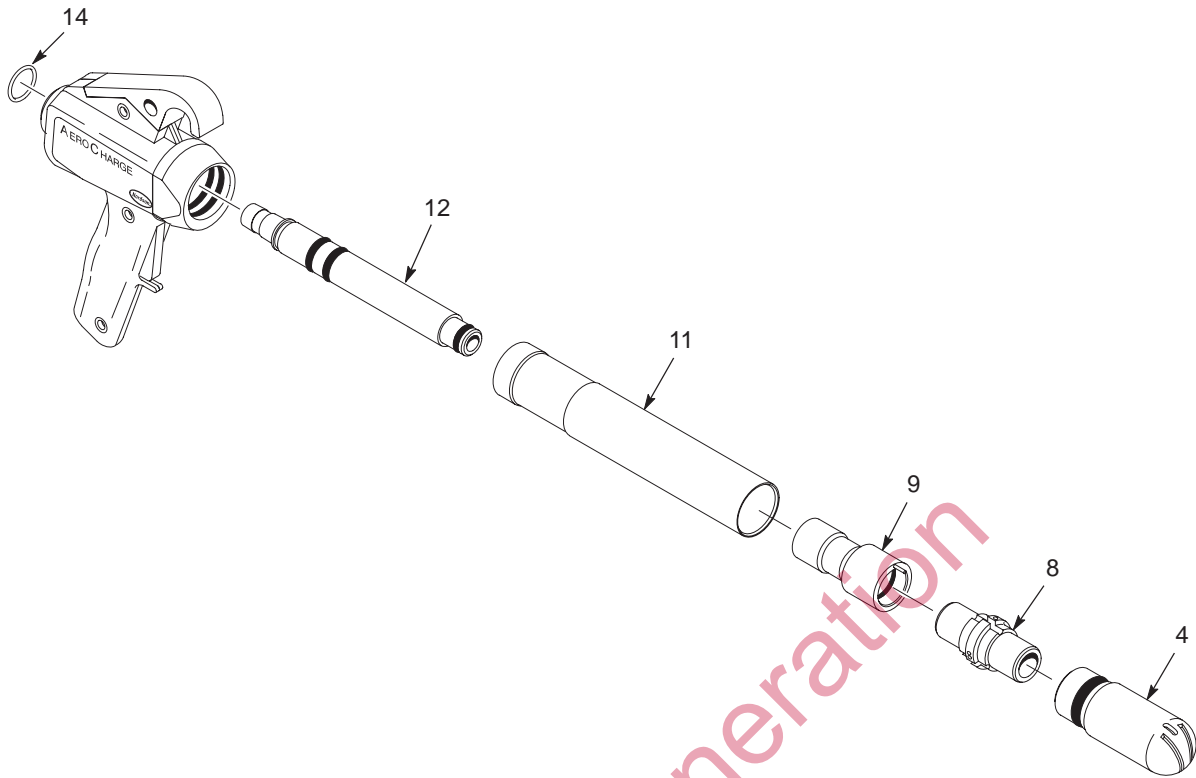

1400266B

Figure 5 Optional Long Gun Extension Kit Installation

- |                  |                        |                       |
|------------------|------------------------|-----------------------|
| 4. Nozzle        | 9. Powder inlet sleeve | 12. Powder inlet tube |
| 8. Charge sleeve | 11. Barrel             | 14. O-ring            |

Note: Item numbers correspond to those in [Figure 8](#).

Previous Generation

## Operation



**WARNING:** Allow only qualified personnel to perform the following tasks. Follow the safety instructions in this document and all other related documentation.



**WARNING:** This equipment can be dangerous unless it is used in accordance with the rules laid down in this manual.



**WARNING:** Use appropriate respiratory protection. Breathing certain airborne dusts (including finishing powders) may be hazardous to your health. For specific guidance, ask the powder manufacturer for a Material Safety Data Sheet (MSDS).



**WARNING:** All conductive equipment in the spray area must be grounded. Ungrounded or poorly grounded equipment can store an electrostatic charge which can give personnel a severe shock or arc and cause a fire or explosion.

**NOTE:** Refer to your control unit manual for more information on how to operate the equipment.

## Startup

1. Make sure that the booth exhaust fans are activated and the powder recovery system is operating.
2. Make sure that the control unit is connected to a true earth ground.
3. Fill the feed hopper  $\frac{2}{3}$  full with new powder.
4. Turn on the main air supply.
5. Allow the powder in the hopper to thoroughly fluidize.

## Spraying Powder

1. Set the flow and atomizing air pressures.  
**Atomizing:** 3.4–3.8 bar (50–55 psi) (recommended)  
**Flow Rate:** as desired (application dependent)
2. Point the spray gun into the booth and squeeze the trigger to test the spray pattern. As necessary, adjust the flow and atomizing air pressures.
3. To promote even wear and longer charge sleeve life, rotate the charge sleeve every four hours. Refer to *Charge Sleeve Rotation* in *Daily Maintenance* for more information.

## Shutdown

1. Turn off and relieve system air pressure.
2. Shut down the control unit and powder coating system as described in the system components' manuals.
3. Perform the *Daily Maintenance* procedures.

## Daily Maintenance



**WARNING:** Allow only qualified personnel to perform the following tasks. Follow the safety instructions in this document and all other related documentation.

## Cleaning



**WARNING:** Never blow out the spray gun if the control unit is not grounded. A potentially dangerous charge will build up in the spray gun which can cause severe electrical shock.



**CAUTION:** Always blow out the feed hose in the direction of powder flow (from pump to spray gun). Never blow out the feed hose from the spray gun back into the pump.

1. Disconnect the powder feed hose from the pump.
  2. Blow out the powder feed hose.
  3. Disassemble and clean the pump. Replace worn parts.
  4. Disconnect the powder feed hose from the spray gun and blow out the spray gun.
  5. Remove the charge sleeve and inspect it. Refer to *Charge Sleeve Rotation* for guidelines and instructions. Do not assemble the spray gun at this time.
    - If there is impact fusion present inside the charge sleeve, clean it with acetone.
    - If the charge sleeve's current position shows signs of wear, rotate the charge sleeve to the next available position.
- NOTE:** Replacement charge sleeves are available only in packs of five. Refer to *Recommended Spare Parts* in *Parts* for ordering information.
6. Clean all of the spray gun's parts and assemble the spray gun.
  7. Connect the powder feed hose.

## Charge Sleeve Rotation

During normal operation, the stream of compressed air and powder impacts a localized area inside the charge sleeve. Over time, this may cause wear or impact fusion to the internal charge sleeve surface.

See Figure 6.

There are three positioning grooves on the circumference of the charge sleeve (8). The charge sleeve may be used on both ends, which doubles the number of positions available. The positioning grooves have identification marks (A) to help reference the charge sleeve's position.

The charge sleeve should be rotated after approximately four hours of use. Depending on the application (and variables such as powder characteristics and flow), a charge sleeve can typically last approximately 96 hours if it is rotated every four hours of use.

**NOTE:** If the charge sleeve does not appear to be worn out after 96 hours of use, you may continue to use it. However, if the charge sleeve shows signs of wear in less than 96 hours of use, you will need to replace it.

See Figure 6.

1. Twist and pull the nozzle (4) off the spray gun. The nozzle, charge sleeve (8), and powder inlet sleeve (9) should come out of the spray gun.

**NOTE:** If the charge sleeve and powder inlet sleeve do not come out with the nozzle, twist and pull the barrel (11) out of the spray gun to expose the charge sleeve and powder inlet sleeve. Remove the charge sleeve and powder inlet sleeve and install the barrel onto the spray gun.

2. Separate the nozzle, charge sleeve, and powder inlet sleeve if they are still assembled.
3. Inspect all O-rings and replace them as necessary.
4. Turn the charge sleeve to the next position. After all three positions have been used on one end of the charge sleeve, flip the charge sleeve over and begin using the other three positions. After all six positions have been worn out, replace the charge sleeve.
5. Insert the charge sleeve into the powder inlet sleeve, making sure the pin on the end of the powder inlet sleeve slides into the correct positioning groove on the charge sleeve. The pin holds the charge sleeve in place and marks the current position of the sleeve.
6. Insert the nozzle onto the opposite end of the charge sleeve.
7. Insert the powder inlet sleeve, charge sleeve, and nozzle into the barrel and push them onto the powder inlet tube.

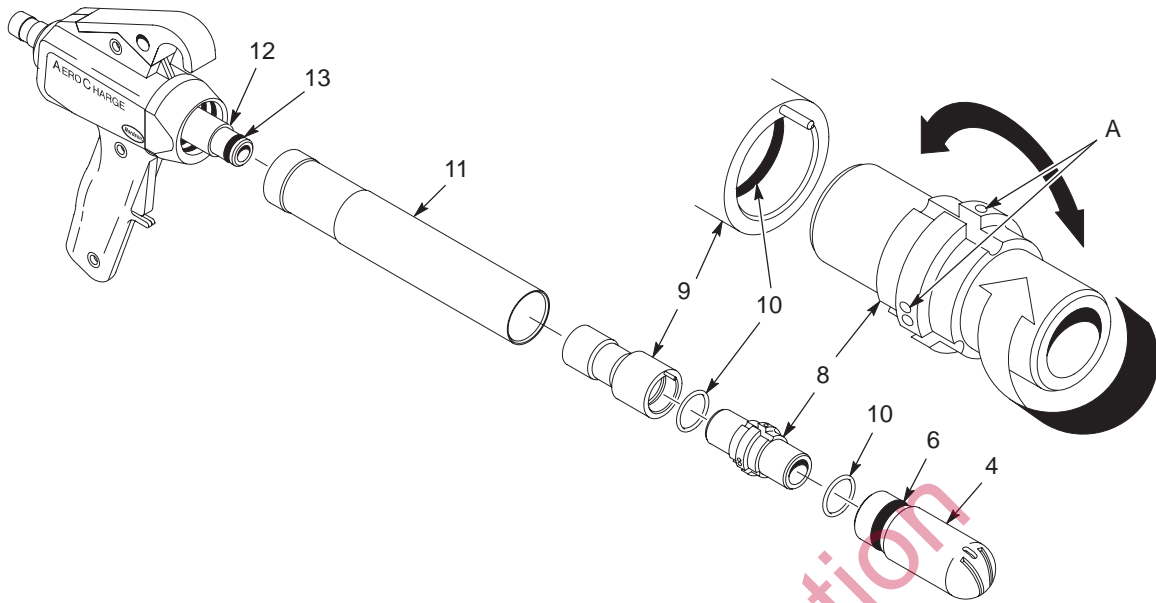

1400268B

Figure 6 Charge Sleeve Rotation

- |                         |                        |                       |
|-------------------------|------------------------|-----------------------|
| A. Identification marks | 8. Charge sleeve       | 11. Barrel            |
| 4. Nozzle               | 9. Powder inlet sleeve | 12. Powder inlet tube |
| 6. O-ring               | 10. O-ring             | 13. O-ring            |

Note: Item numbers correspond to those in [Figure 8](#).

Previous Generation

## Troubleshooting



**WARNING:** Allow only qualified personnel to perform the following tasks. Follow the safety instructions in this document and all other related documentation.

This section contains troubleshooting procedures. These procedures cover only the most common problems that you may encounter. If you cannot solve the problem with the information given here, contact your local Nordson representative for help.

Problem	Possible Cause	Corrective Action
1. Powder does not flow when spray gun is triggered	No supply air or pressure set too low	Make sure the control unit is getting air. Check the supply air pressure. Minimum test air pressure is 2.8 bar (40 psi).
	Blockage in system	Shut down the system and clean it, starting with the pump. Check the air dryer for proper operation, drain the air filters, and inspect the filter element. Make sure the powder supply in the feed hopper is dry.
	Trigger switch in spray gun not opening	Replace the spray gun cable. Refer to <i>Cable Replacement</i> for instructions.
	Control unit malfunction	Contact your Nordson Corporation representative.
2. Powder puffing from spray gun	Flow rate air pressure too low or atomizing air pressure is too high	Increase flow rate air pressure or decrease atomizing air pressure.
	Blockage in system	Shut down the system. Clean the system starting with the pump.
	Pump venturi throat worn	Replace the venturi throat.
	Atomizing air pressure too high or incorrect ratio of atomizing to flow rate air pressure	Decrease atomizing air pressure or increase flow rate air pressure.
Powder feed hose ID too large or hose too short	Change to smaller ID hose or change hose length.	<b>Recommended Feed Hose Length:</b> 6–7.5 m (20–25 ft)
	<b>Recommended Feed Hose ID:</b> 3/8 in.	

*Continued...*

Problem	Possible Cause	Corrective Action
<b>3. Poor powder charging—no electrostatic wrap or adhesion</b>	<p>Flow rate air pressure too high</p> <p>Too much moisture in compressed air supply</p> <p>Charge sleeve worn out or impact fusion building on ID</p> <p>Parts not properly grounded</p> <p>Loss of spray gun ground continuity</p> <p>Too many fine particles in powder supply</p> <p>Powder not suitable for AeroCharge system</p>	<p>Decrease the flow rate air pressure.</p> <p>Check the air dryer for proper operation. Use a refrigerated or regenerative desiccant air dryer that can produce a 3.4 °C (38 °F) or lower dew point at 7 bar (100 psi). Drain the air filter and check the filter element.</p> <p>Rotate or reverse the charge sleeve. Use solvent to clean any impact fusion. Replace the charge sleeve if necessary.</p> <p>Check the conveyor and hangers with an ohmmeter for coating buildup that could affect ground. Resistance between the parts and ground should not exceed 1 megohm. For best results, resistance should not exceed 500 ohms.</p> <p>Clean the spray gun barrel ID and the charge sleeve.  <a href="#">See Figure 7.</a> Shut down the spray gun, separate the handle halves, and check the spray gun's internal ground connections. Tighten loose ground connections.</p> <p>Replace the powder supply with virgin powder. Consult with the powder manufacturer.</p> <p>Consult with the powder manufacturer.</p>
<b>4. Inadequate powder flow</b>	<p>Flow rate air pressure too low</p> <p>Atomizing air pressure too high</p> <p>Wet powder causing clogging and restriction in system</p>	<p>Increase the flow rate air pressure.</p> <p>Decrease the atomizing air pressure.</p> <p>Check the air filters, dryer, and powder supply. Service the filters and/or dryer and change the powder supply.</p>

## Troubleshooting *(contd)*

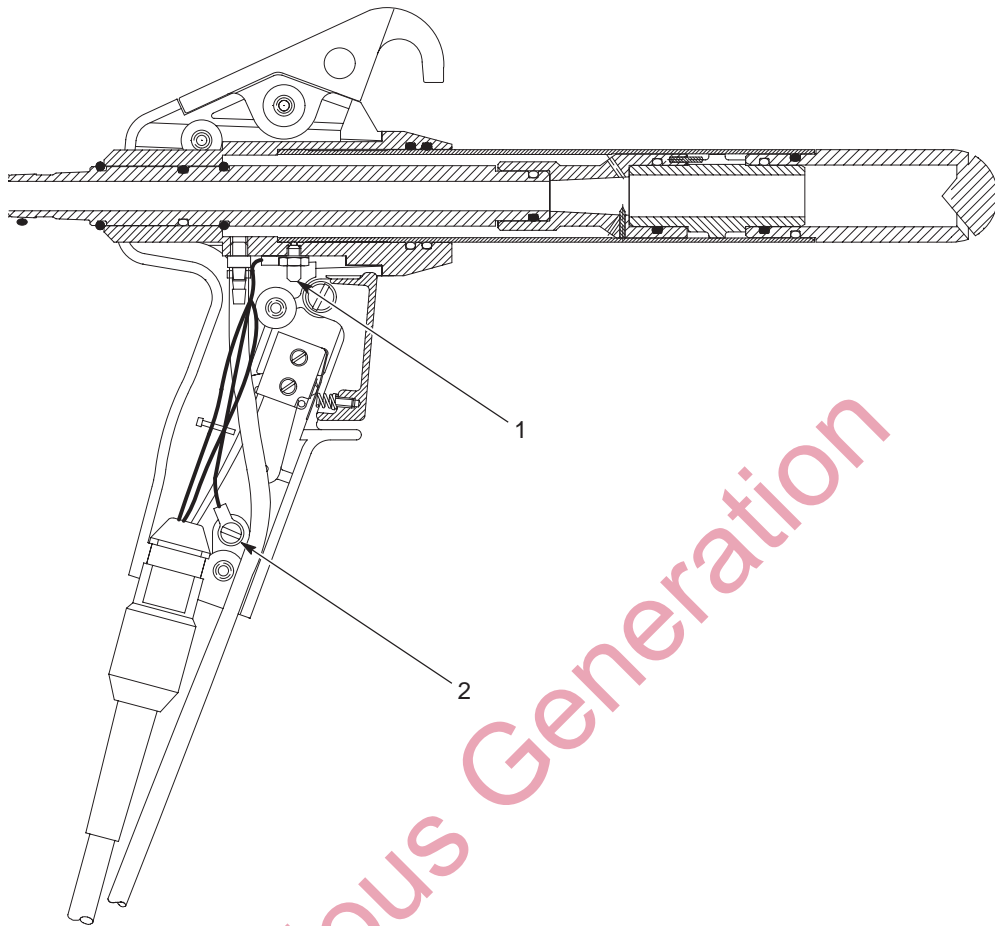

1400451A

Figure 7 Internal Ground Connections

1. Blue ground jumper termination
2. Green ground jumper termination

## Repair



**WARNING:** Allow only qualified personnel to perform the following tasks. Follow the safety instructions in this document and all other related documentation.

Use the following procedures to replace the spray gun's wear items. Refer to *Parts* for replacement part ordering information.

### ***Powder Inlet Tube Replacement***

See Figure 8.

1. Remove the O-ring (14) from the end of the powder inlet tube (12).
2. Pull the nozzle (4 or 5), charge sleeve (8), and powder inlet sleeve (9), from the powder inlet tube and barrel (11).
3. Pull the barrel off the spray gun using a slight twisting motion.
4. Inspect all O-rings and replace them as necessary.
5. Inspect the charge sleeve for impact fusion or wear. Refer to *Charge Sleeve Rotation* in *Daily Maintenance* for information on how to rotate, clean, and/or replace the charge sleeve.
6. Push the powder inlet tube out the front of the spray gun.
7. Insert the new powder inlet tube through the front of the spray gun.
8. Install the O-ring onto the end of the new powder inlet tube.
9. Install the barrel onto the spray gun.
10. Insert the powder inlet sleeve, charge sleeve, and nozzle into the barrel.

## ***Powder Inlet Sleeve Replacement***

See Figure 8.

1. Twist and pull the nozzle (4 or 5) off the spray gun. The nozzle, charge sleeve (8), and powder inlet sleeve (9) should come out of the spray gun.

**NOTE:** If the powder inlet sleeve does not come out with the other pieces, twist and pull the barrel (11) out of the spray gun to expose and remove the powder inlet sleeve. Install the barrel onto the spray gun.

2. Pull the powder inlet sleeve from the charge sleeve and nozzle.
3. Inspect the O-rings on the new powder inlet sleeve and on the nozzle and replace if necessary.
4. Inspect the charge sleeve for impact fusion or wear. Refer to *Charge Sleeve Rotation* in *Daily Maintenance* for information on how to rotate and/or replace the charge sleeve.
5. Slide the new powder inlet sleeve over the end of the charge sleeve, making sure the pin on the end of the powder inlet sleeve slides into the appropriate groove on the charge sleeve. The pin holds the charge sleeve in place and marks the current position of the sleeve.
6. Insert the powder inlet sleeve, charge sleeve, and nozzle into the barrel and push them onto the powder inlet tube.

Previous Generation

## Cable Replacement

### Removal

See Figure 8.

1. Loosen the cable's lock nut and disconnect the cable from the control unit.
2. Loosen the captive screws in the handle (21). Separate the handle halves.
3. Remove the body (15) from the handle.
4. Loosen the nut (18) to remove the blue ground wire from the spring plunger (17).
5. Loosen the screw (27) to disconnect the green ground wire from the handle.
6. Remove the screws and washers (29, 30, and 31) securing the trigger switch and actuator (33) to the handle.
7. Grasp the cable by its base and lift the cable out of the handle.

### Installation

See Figure 8.

1. Secure the new cable's green ground wire to the handle using the screw (27).

**NOTE:** The cable wiring should lay over the blue air tubing as the handle is being assembled.

2. Secure the blue ground wire to the spring plunger (17) using the nut (18).
3. Secure the trigger switch and actuator (33) to the handle (21) using the screws and washers (29, 30, and 31).
4. Arrange the blue air tubing (32) beneath the wiring and around the trigger switch. Carefully snap the air tubing into its notch in the handle.
5. Set the handle halves together, being careful not to pinch any of the cable wiring.
6. Secure the handle halves together using the three captive screws.
7. Connect the cable to the control unit and tighten the cable's lock nut.

This page intentionally left blank.

Previous Generation

## Parts

To order parts, call the Nordson Customer Service Center or your local Nordson representative. Use this five-column parts list, and the accompanying illustration, to describe and locate parts correctly.

### Using the Illustrated Parts List

Numbers in the Item column correspond to numbers that identify parts in illustrations following each parts list. The code NS (not shown) indicates that a listed part is not illustrated. A dash (—) is used when the part number applies to all parts in the illustration.

The number in the Part column is the Nordson Corporation part number. A series of dashes in this column (-----) means the part cannot be ordered separately.

The Description column gives the part name, as well as its dimensions and other characteristics when appropriate. Indentions show the relationships between assemblies, subassemblies, and parts.

- If you order the assembly, items 1 and 2 will be included.
- If you order item 1, item 2 will be included.
- If you order item 2, you will receive item 2 only.

The number in the Quantity column is the quantity required per unit, assembly, or subassembly. The code AR (As Required) is used if the part number is a bulk item ordered in quantities or if the quantity per assembly depends on the product version or model.

Letters in the Note column refer to notes at the end of each parts list. Notes contain important information about usage and ordering. Special attention should be given to notes.

Item	Part	Description	Quantity	Note
—	0000000	Assembly	1	
1	000000	• Subassembly	2	A
2	000000	• • Part	1	

## AeroCharge Electronic Manual Powder Spray Gun Parts

See Figure 8.

Item	Part	Description	Quantity	Note
—	1017297	HAND GUN, electronic, AeroCharge	1	
1	1018584	• DEFLECTOR, 2-in. pattern adjustable, with O-ring, AeroCharge	1	
2	1018585	• DEFLECTOR, 3-in. pattern adjustable, with O-ring, AeroCharge	1	
3	941224	• • O-RING, silicone, 1.125 x 1.312 x 0.094 in.	2	A
4	1018588	• NOZZLE, dual slot with side slot, with O-rings, AeroCharge	1	
5	1018587	• NOZZLE, conical, -50 degree, with O-rings, AeroCharge	1	
6	941176	• • O-RING, silicone, 0.813 x 1.000 x 0.094 in.	2	B
7	941162	• • O-RING, silicone, 0.750 x 0.937 x 0.094 in.	2	B
8	1018340	• CHARGE SLEEVE, kit, AeroCharge 5 pack	5	C
9	1018589	• SLEEVE, powder inlet, assembly	1	
10	941162	• • O-RING, silicone, 0.750 x 0.937 x 0.094 in.	1	
11	1015627	• BARREL, AeroCharge	1	
12	1018586	• TUBE, powder inlet, with O-rings	1	
13	941113	• • O-RING, silicone, 0.438 x 0.625 x 0.094 in.	1	
14	941131	• • O-RING, silicone, 0.563 x 0.750 x 0.094 in.	3	
15	-----	• BODY, handle interface, AeroCharge	1	
16	941224	• O-RING, silicone, 1.125 x 1.312 x 0.094 in.	2	
17	281092	• PLUNGER, spring, 8–32 UNC	1	
18	984111	• NUT, hex, machined, #8–32, steel, zinc	1	
19	939110	• STRAP, cable, 0.875-in. diameter	1	
20	1017280	• FITTING, barb, 6-mm tube x M5 thread	1	
21	-----	• HANDLE, set	1	
22	302422	• HANGER	1	
23	125617	• TRIGGER	1	
24	132334	• PIVOT, trigger	1	
25	133783	• SPRING, trigger, return	1	
26	982370	• SCREW, pan, slotted, M2 x 5, zinc	1	
27	982487	• SCREW, pan, slot, M4 x 5 mm	1	
28	305776	• CABLE, T2, 8 m	1	
29	981915	• SCREW, pan, 2-56 x 0.375 in., slotted, zinc	2	
30	983113	• WASHER, lock, e, split, 2, steel, zinc	2	
31	983510	• WASHER, flat, e, 0.094 x 0.188 x 0.025 in., brass	2	
32	900742	• TUBING, polyurethane, 6 mm, blue	8.25 m	
33	132336	• ACTUATOR, switch	1	
NS	972286	• REDUCER, 8-mm stem x 6-mm tube	1	D
NS	305776	• CABLE, adapter, Tribo/Sure Coat	1	D
NS	247006	• CLAMP, hose, 0.673–0.795-in. OD	1	
NS	900517	• TUBING, poly, spiral cut, 0.62-in. ID	2 ft	

NOTE A: This O-ring is included with both deflectors.

B: These O-rings are included with both nozzles.

C: You must order charge sleeves in packs of five, part 1018340. Charge sleeves are not sold individually.

D: Use these parts only when connecting the spray gun to a Sure Coat control unit.

NS: Not Shown

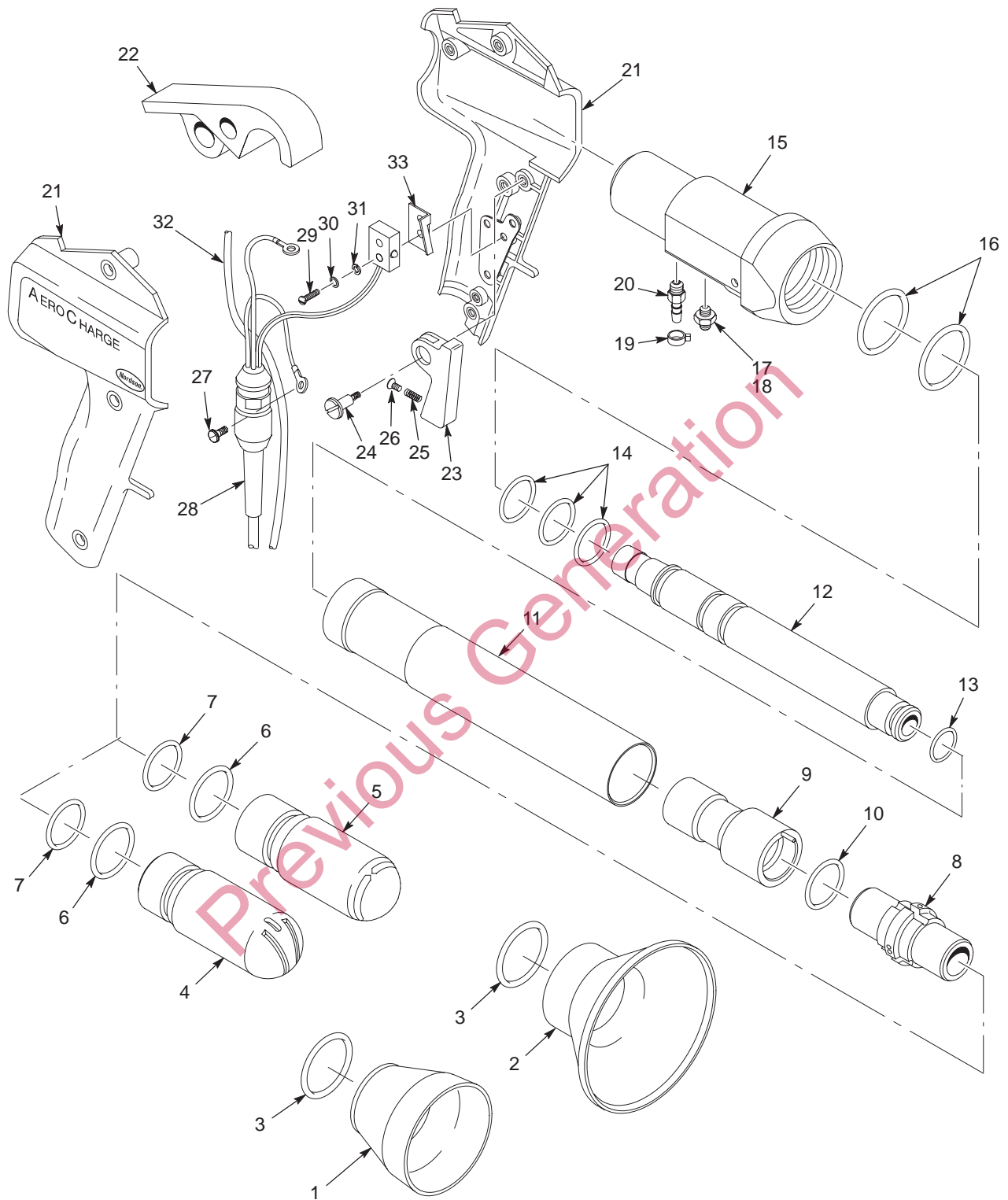

1400452A

Figure 8 AeroCharge Electronic Manual Powder Spray Gun Parts

**Extension Kits**

**Barrel Extension Kit**

See Figure 9.

Item	Part	Description	Quantity	Note
—	1017809	KIT, 4-in. extension, AeroCharge, spray gun		
A	1015586	• EXTENSION, powder inlet, AeroCharge	1	
B	1015585	• EXTENSION, barrel, 4 in. AeroCharge	1	
C	1023528	• O-RING, polyurethane, 0.813 x 1.000 x 0.094, Duro	1	
D	941178	• O-RING, silicone, conductive, 0.813 x 1.000 x 0.094 in.	1	
13	941113	• O-RING, silicone, 0.438 x 0.625 x 0.094 in.	1	

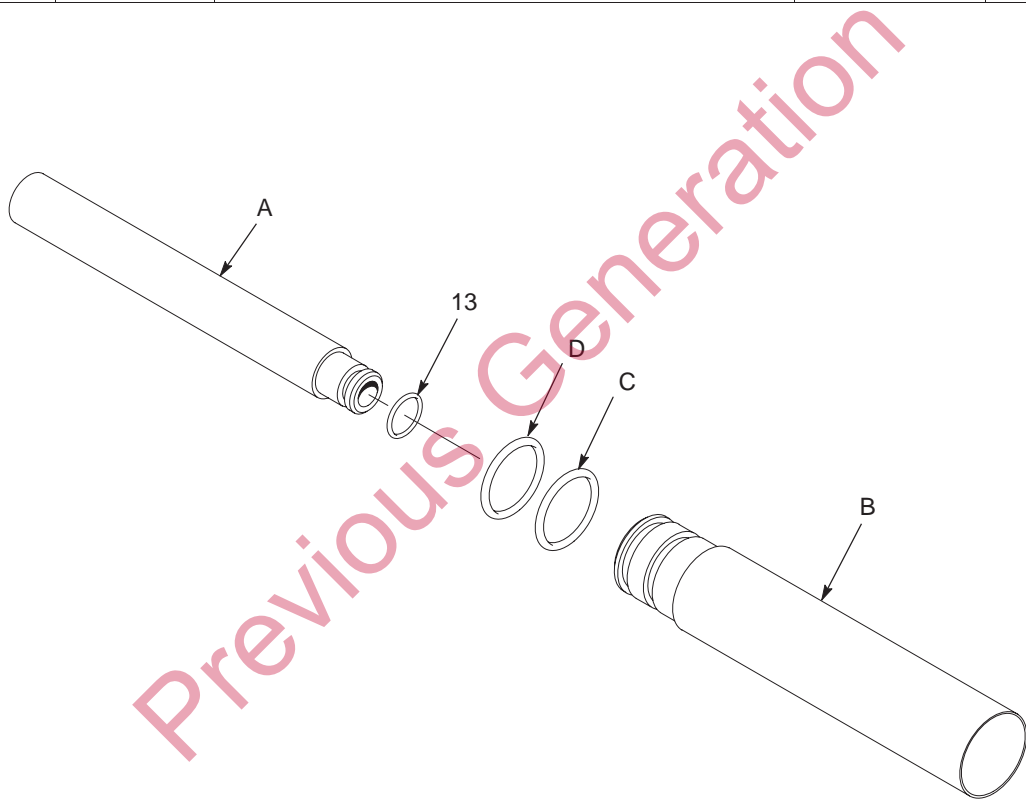

1400270B

Figure 9 Barrel Extension Kit

## Long Gun Extension Kit

See Figure 10.

Item	Part	Description	Quantity	Note
—	1017890	KIT, fixed, barrel, extended AeroCharge spray gun	1	
A	1015630	• TUBE, powder, inlet, extended, AeroCharge	1	
B	1015628	• BARREL, extended, AeroCharge	1	
13	941113	• O-RING, silicone, 0.438 x 0.625 x 0.094 in.	1	
14	941131	• O-RING, silicone, 0.563 x 0.750 x 0.094 in.	3	

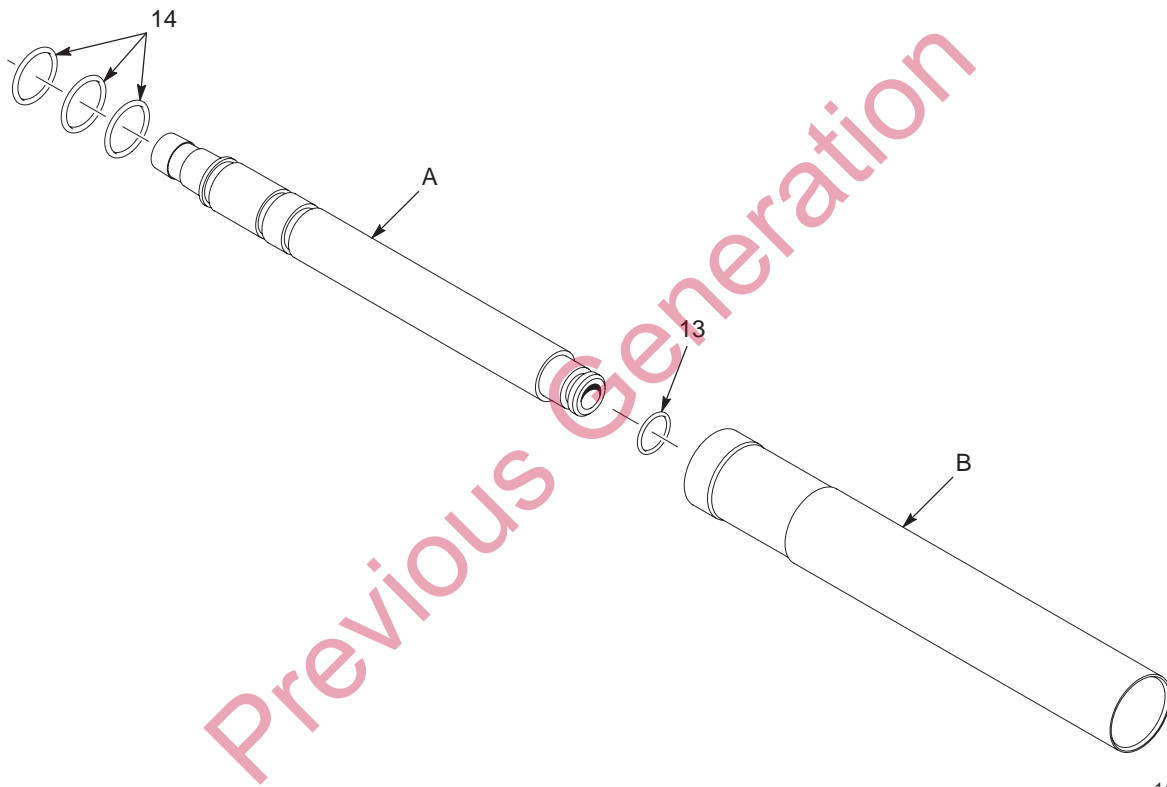

1400271B

Figure 10 Long Gun Extension Kit

## Nozzles and Deflectors

See Figure 8.

Item	Part	Description	Quantity	Note
1	1018584	DEFLECTOR, 2-in. pattern adjustable, with O-ring, AeroCharge	1	
2	1018585	DEFLECTOR, 3-in. pattern adjustable, with O-ring, AeroCharge	1	
3	941224	• O-RING, silicone, 1.125 x 1.312 x 0.094 in.	1	A
4	1018588	NOZZLE, dual slot with side slot, with O-rings, AeroCharge	1	
5	1018587	NOZZLE, conical, -50 degree, with O-rings, AeroCharge	1	
6	941176	• O-RING, silicone, 0.813 x 1.000 x 0.094 in.	1	B
7	941162	• O-RING, silicone, 0.750 x 0.937 x 0.094 in.	1	B
NOTE A: This O-ring is included with both deflectors.				
B: These O-rings are included with both nozzles.				

## Recommended Spare Parts

See Figure 8.

Item	Part	Description	Quantity	Note
8	1018340	CHARGE SLEEVE, kit, AeroCharge, 5 pack	1	
9	1018589	SLEEVE, powder inlet, assembly, AeroCharge	1	
10	941162	• O-RING, silicone, 0.750 x 0.937 x 0.094 in.	1	
12	1018586	TUBE, powder inlet with O-rings, AeroCharge	1	
13	941113	• O-RING, silicone, 0.438 x 0.625 x 0.094 in.	1	
14	941131	• O-RING, silicone, 0.563 x 0.750 x 0.094 in.	3	

# DECLARATION of CONFORMITY

**PRODUCT:**

AeroCharge Powder Spray System

This is an air-charging powder spray system.

**APPLICABLE DIRECTIVES:**

89/37/EEC (Machinery)

**STANDARDS USED TO VERIFY COMPLIANCE:**

EN292

IEC417L

prEN50050 (This meets the maximum charge energy requirements of this draft standard.)

**PRINCIPLES:**

This product has been manufactured according to good engineering practice.

The product specified conforms to the directive and standards described above.

**CERTIFICATIONS:**

ISO 9001 DNV No. QSC3277

EECS (Notified Body No. 600) EECS ATEX 0771



---

Cynthia A. Skelton-Becker  
Director of Engineering, Powder Systems Group

Date: 20 September 2001



Previous Generation

Previous Generation

Previous Generation