

# 58:1 QS Pump System

Customer Product Manual  
Part 331 281A



NORDSON CORPORATION • AMHERST, OHIO • USA

Nordson Corporation welcomes requests for information, comments and inquiries about its products. General information about Nordson can be found on the Internet using the following address: <http://www.nordson.com>.

Address all correspondence to:

Nordson Corporation  
Attn: Customer Service  
555 Jackson Street  
Amherst, OH 44001

#### Notice

This is a Nordson Corporation publication which is protected by copyright. Original copyright date 2000. No part of this document may be photocopied, reproduced, or translated to another language without the prior written consent of Nordson Corporation. The information contained in this publication is subject to change without notice.

#### Trademarks

AccuJet, AquaGuard, Asymtek, Automove, Autotech, Blue Box, CF, CanWorks, Century, Clean Coat, CleanSleeve, CleanSpray, Compumelt, Control Coat, Cross-Cut, Cyclo-Kinetic, Dispensejet, DispenseMate, Durafiber, Durasystem, Easy Coat, Easymove Plus, Econo-Coat, EPREG, ETI, Excel 2000, Flex-O-Coat, FlexiCoat, Flexi-Spray, Flow Sentry, Fluidmove, Fluidshooter, FoamMelt, FoamMix, Helix, Horizon, Hose Mole, Hot Shot, Hot Stitch, Isocoil, Isocore, Iso-Flo, JR, KB30, Little Squirt, Magnastatic, MEG, Meltex, MicroSet, Millenium, Mini Squirt, Moist-Cure, Mountaingate, MultiScan, Nordson, OmniScan, Opticoat, Package of Values, PluraFoam, Porous Coat, PowderGrid, Powderware, Pro-Flo, ProLink, Pro-Meter, Pro-Stream, PRX, RBX, Ready Cost, Rhino, S. design stylized, Saturn, SC5, SCF, Select Charge, Select Coat, Select Cure, Shur-Lok, Slautterback, Smart-Coat, Spray Squirt, Spraymelt, Super Squirt, Sure-Bond, Sure Coat, System Sentry, Tela-Therm, Trends, Tribomatic, UniScan, UpTime, Veritec, Versa-Coat, Versa-Screen, Versa-Spray, Watermark, and When you expect more. are registered trademarks - ® - of Nordson Corporation.

ATS, Auto-Flo, AutoScan, BetterBook, Chameleon, CanNeck, Check Mate, CPX, Control Weave, Controlled Fiberization, EasyClean, Ebraid, Eclipse, Equi=Bead, Fillmaster, Gluie, Ink-Dot, Maxima, MicroFin, Minimeter, Multifil, OptiMix, Pattern View, PluraMix, Primarc, Prism, Process Sentry, PurTech, Pulse Spray, Seal Sentry, Select Series, Sensomatic, Shaftshield, Spectral, Spectrum, Sure Brand, Swirl Coat, Vista, Walcom, and 2 Rings (Design) are trademarks - ® - of Nordson Corporation.

All other trademarks are the property of their respective owners.

# Table of Contents

1. Safety	1
Qualified Personnel	1
Intended Use	1
Regulations and Approvals	1
Personal Safety	2
High-Pressure Fluids	3
Fire Safety	4
Halogenated Hydrocarbon Solvent Hazards	5
Action in the Event of a Malfunction	5
Disposal	5
2. Description	6
Pump	8
Air Motor	8
Ram	9
200-Liter Dual Post Ram	9
20-Liter Dual Post Ram	9
20-Liter Single Post Ram	9
Theory of Operation	9
3. Installation	10
Ram Setup	11
4. Operation	12
Ram Director Valve	12
Loading a New Material Container	12
Ram Operation	13

- 5. Maintenance ..... 14
  - Long-Term Shut Down ..... 15
  - Flushing the Sytem ..... 15
- 6. Troubleshooting ..... 16
  - Pump ..... 16
  - Air Motor ..... 18
  - Ram ..... 19
  - Air Motor Icing ..... 20
- 7. Repair ..... 21
  - Pressure Relief ..... 21
  - Air Motor Disassembly ..... 22
    - Removing the Air Motor from the Ram ..... 22
    - Disassembling the Housing ..... 22
    - Disassembling the Air Motor Base ..... 23
    - Final Disassembly ..... 23
  - Air Motor Assembly ..... 24
    - Assembling the Air Motor Base ..... 24
    - Assembling the Housing ..... 25
    - Installing the Air Motor to the Ram ..... 25
  - Pump Disassembly ..... 26
    - Removing the Pump from the Air Motor ..... 26
    - Final Disassembly ..... 27
  - Pump Assembly ..... 28
    - Assembling the Pump Housing ..... 28
    - Final Pump Assembly ..... 29
  - Ram Piston Rod Packing Disassembly ..... 30
  - Ram Piston Rod Packing Assembly ..... 30
  - Ram Piston Disassembly ..... 31
  - Ram Piston Assembly and Installation ..... 31

---

8. Parts .....	32
Using the Illustrated Parts List .....	32
Top Level Assemblies .....	33
Air Motor .....	33
Air Motor Repair Kit .....	37
Pump .....	38
Pump Repair Kit .....	41
200-Liter Dual Post Ram .....	42
200-Liter Dual Post Ram .....	45
20-Liter Dual Post Ram .....	46
20-Liter Dual Post Ram Kit .....	48
Hold Down .....	48
Control Box .....	49
Control Panel .....	50
20-Liter Single Post Ram .....	51
20-Liter Single Post Repair Kit .....	54
9. Specifications .....	55
Air .....	55
Pump .....	55
Dimensions and Weights .....	55
10. Options .....	56
Electric Automatic Changeover .....	56
Low-Level Indicator .....	56
Hold Down .....	56
Control Box .....	56



---

# 58:1 QS Pump System

---

## 1. Safety

---

Read and follow these safety instructions. Task- and equipment-specific warnings, cautions, and instructions are included in equipment documentation where appropriate.

Make sure all equipment documentation, including these instructions, is accessible to persons operating or servicing equipment.

### ***Qualified Personnel***

Equipment owners are responsible for making sure that Nordson equipment is installed, operated, and serviced by qualified personnel. Qualified personnel are those employees or contractors who are trained to safely perform their assigned tasks. They are familiar with all relevant safety rules and regulations and are physically capable of performing their assigned tasks.

### ***Intended Use***

Use of Nordson equipment in ways other than those described in the documentation supplied with the equipment may result in injury to persons or damage to property.

Some examples of unintended use of equipment include

- using incompatible materials
- making unauthorized modifications
- removing or bypassing safety guards or interlocks
- using incompatible or damaged parts
- using unapproved auxiliary equipment
- operating equipment in excess of maximum ratings

### ***Regulations and Approvals***

Make sure all equipment is rated and approved for the environment in which it is used. Any approvals obtained for Nordson equipment will be voided if instructions for installation, operation, and service are not followed.

## **Personal Safety**

To prevent injury follow these instructions.

- Do not operate or service equipment unless you are qualified.
- Do not operate equipment unless safety guards, doors, or covers are intact and automatic interlocks are operating properly. Do not bypass or disarm any safety devices.
- Keep clear of moving equipment. Before adjusting or servicing moving equipment, shut off the power supply and wait until the equipment comes to a complete stop. Lock out power and secure the equipment to prevent unexpected movement.
- Relieve (bleed off) hydraulic and pneumatic pressure before adjusting or servicing pressurized systems or components. Disconnect, lock out, and tag switches before servicing electrical equipment.
- While operating manual spray guns, make sure you are grounded. Wear electrically conductive gloves or a grounding strap connected to the gun handle or other true earth ground. Do not wear or carry metallic objects such as jewelry or tools.
- If you receive even a slight electrical shock, shut down all electrical or electrostatic equipment immediately. Do not restart the equipment until the problem has been identified and corrected.
- Obtain and read Material Safety Data Sheets (MSDS) for all materials used. Follow the manufacturer's instructions for safe handling and use of materials, and use recommended personal protection devices.
- Make sure the spray area is adequately ventilated.
- To prevent injury, be aware of less-obvious dangers in the workplace that often cannot be completely eliminated, such as hot surfaces, sharp edges, energized electrical circuits, and moving parts that cannot be enclosed or otherwise guarded for practical reasons.

### **High-Pressure Fluids**

High-pressure fluids, unless they are safely contained, are extremely hazardous. Always relieve fluid pressure before adjusting or servicing high pressure equipment. A jet of high-pressure fluid can cut like a knife and cause serious bodily injury, amputation, or death. Fluids penetrating the skin can also cause toxic poisoning.

If you suffer a fluid injection injury, seek medical care immediately. If possible, provide a copy of the MSDS for the injected fluid to the health care provider.

The National Spray Equipment Manufacturers Association has created a wallet card that you should carry when you are operating high-pressure spray equipment. These cards are supplied with your equipment. The following is the text of this card:



**WARNING:** Any injury caused by high pressure liquid can be serious. If you are injured or even suspect an injury:

- Go to an emergency room immediately.
- Tell the doctor that you suspect an injection injury.
- Show him this card.
- Tell him what kind of material you were spraying.

#### **MEDICAL ALERT—AIRLESS SPRAY WOUNDS: NOTE TO PHYSICIAN**

Injection in the skin is a serious traumatic injury. It is important to treat the injury surgically as soon as possible. Do not delay treatment to research toxicity. Toxicity is a concern with some exotic coatings injected directly into the bloodstream.

Consultation with a plastic surgeon or a reconstructive hand surgeon may be advisable.

The seriousness of the wound depends on where the injury is on the body, whether the substance hit something on its way in and deflected causing more damage, and many other variables including skin microflora residing in the paint or gun which are blasted into the wound. If the injected paint contains acrylic latex and titanium dioxide that damage the tissue's resistance to infection, bacterial growth will flourish. The treatment that doctors recommend for an injection injury to the hand includes immediate decompression of the closed vascular compartments of the hand to release the underlying tissue distended by the injected paint, judicious wound debridement, and immediate antibiotic treatment.

## **Fire Safety**

To avoid a fire or explosion, follow these instructions.

- Ground all conductive equipment in the spray area. Use only grounded air and fluid hoses. Check equipment and workpiece grounding devices regularly. Resistance to ground must not exceed one megohm.
- Shut down all equipment immediately if you notice static sparking or arcing. Do not restart the equipment until the cause has been identified and corrected.
- Do not smoke, weld, grind, or use open flames where flammable materials are being used or stored.
- Do not heat materials to temperatures above those recommended by the manufacturer. Make sure heat monitoring and limiting devices are working properly.
- Provide adequate ventilation to prevent dangerous concentrations of volatile particles or vapors. Refer to local codes or your material MSDS for guidance.
- Do not disconnect live electrical circuits while working with flammable materials. Shut off power at a disconnect switch first to prevent sparking.
- Know where emergency stop buttons, shutoff valves, and fire extinguishers are located. If a fire starts in a spray booth, immediately shut off the spray system and exhaust fans.
- Shut off electrostatic power and ground the charging system before adjusting, cleaning, or repairing electrostatic equipment.
- Clean, maintain, test, and repair equipment according to the instructions in your equipment documentation.
- Use only replacement parts that are designed for use with original equipment. Contact your Nordson representative for parts information and advice.

### ***Halogenated Hydrocarbon Solvent Hazards***

Do not use halogenated hydrocarbon solvents in a pressurized system that contains aluminum components. Under pressure, these solvents can react with aluminum and explode, causing injury, death, or property damage. Halogenated hydrocarbon solvents contain one or more of the following elements:

<u>Element</u>	<u>Symbol</u>	<u>Prefix</u>
Fluorine	F	"Fluoro-"
Chlorine	Cl	"Chloro-"
Bromine	Br	"Bromo-"
Iodine	I	"Iodo-"

Check your material MSDS or contact your material supplier for more information. If you must use halogenated hydrocarbon solvents, contact your Nordson representative for information about compatible Nordson components.

### ***Action in the Event of a Malfunction***

If a system or any equipment in a system malfunctions, shut off the system immediately and perform the following steps:

- Disconnect and lock out system electrical power. Close hydraulic and pneumatic shutoff valves and relieve pressures.
- Identify the reason for the malfunction and correct it before restarting the system.

### ***Disposal***

Dispose of equipment and materials used in operation and servicing according to local codes.

---

## 2. Description

---

See Figure 1.

The 58:1 QS pump system delivers Nordson-approved adhesives and sealant materials at room temperature from 20-liter pails and 200-liter drums according to your specific system configuration.

The three available systems are distinguished by their ram configurations:

- 200-liter dual post
- 20-liter dual post
- 20-liter single post

The pump system has pneumatic operating controls and includes a pump (9), an air motor (1), a single or dual post ram (13), and all necessary pneumatic filters, and valves.

20-liter systems can be equipped with an optional pneumatic pail hold down. Refer to the *Options* section for more information.

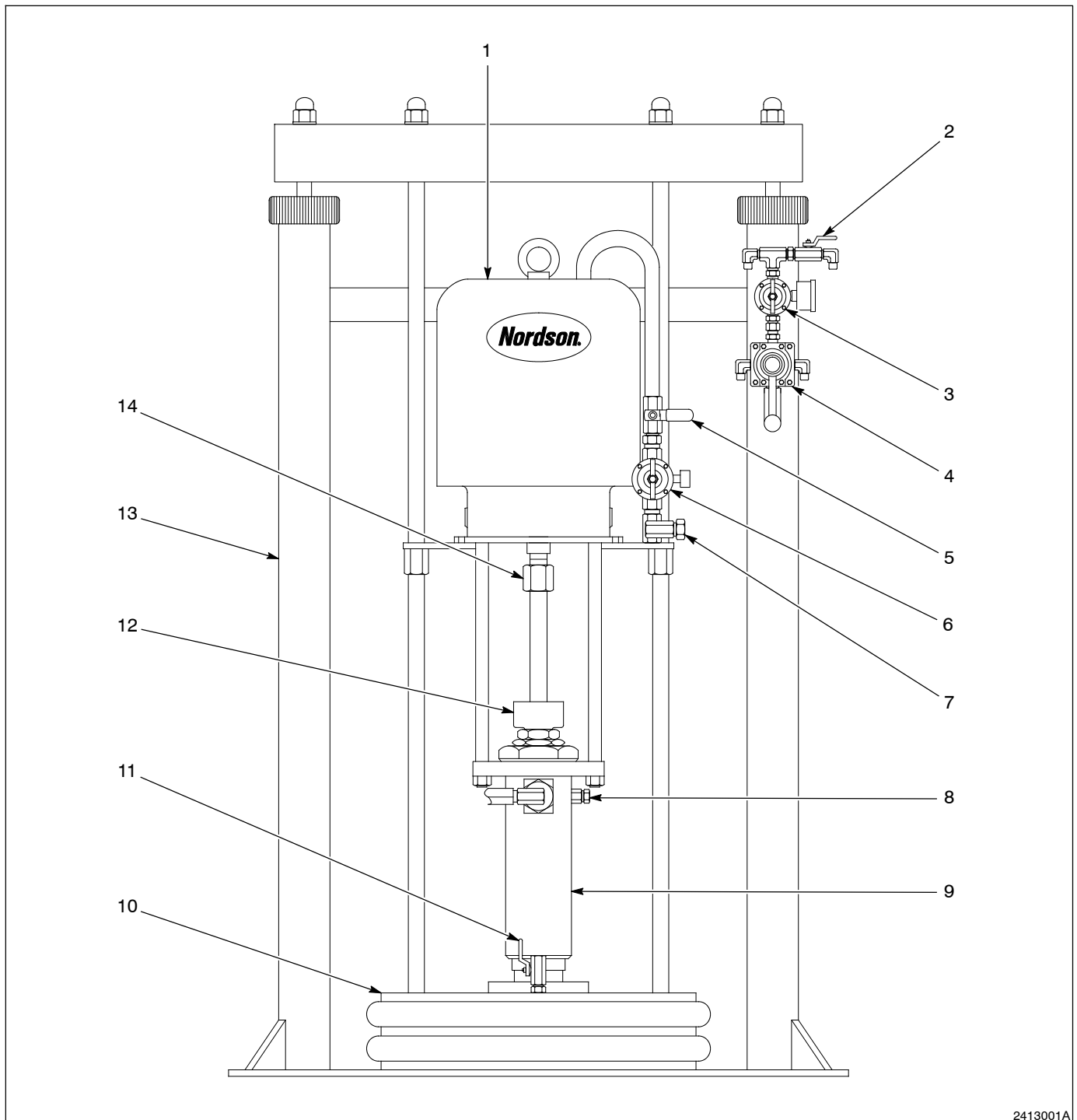

2413001A

Fig. 1 58:1 QS Pump System

- |                           |                       |                 |
|---------------------------|-----------------------|-----------------|
| 1. Air motor              | 6. Pump air regulator | 11. Check valve |
| 2. Blow-off valve         | 7. Air manifold       | 12. Solvent cup |
| 3. Ram air regulator      | 8. Pump bleed valve   | 13. Ram         |
| 4. Ram director valve     | 9. Pump               | 14. Coupling    |
| 5. Air motor on/off valve | 10. Wiper plate       |                 |

## Pump

See Figure 1.

The dual-acting pump (9) is air-operated, featuring positive displacement and demand-type operation. The pump delivers a constant supply of material to dispensing devices or process applicators. The pump shaft connects to the air motor shaft via a coupling (14). A wiper plate (10) or pail disk attaches to the lower end of the pump.

The 200-liter dual post configurations include a wiper plate with wipers. The 20-liter dual and single post configurations include a small-diameter wiper blade, referred to as a pail disk. Refer to the *Parts* section for more information.



**CAUTION:** If the material is too abrasive or not compatible, equipment may wear out prematurely and components may be damaged.

The pump handles high-viscosity materials as well as certain abrasive materials. Contact your Nordson Corporation representative to make sure the material you wish to pump is compatible with your equipment and your components.

**NOTE:** Contact your Nordson representative for hose specifications and ordering details.

## Air Motor



**WARNING:** The moving air motor piston can pinch or amputate fingers. Keep clear of all moving parts when starting or operating the air motor.

See Figure 1.

All 58:1 QS pump system configurations include an air motor (1) that delivers a 58:1 pump ratio. The air motor mounts to the ram (13) above the pump (9). The coupling (14) connects the air motor shaft with the pump shaft.

## **Ram**

See Figure 1.

The ram (13) represents a two piston elevator frame that lifts the pump assembly (9) and the air motor (1).

Some of the listed components might not apply to your system, depending on your specific ram configuration.

**NOTE:** Procedures can vary slightly between models.

### ***200-Liter Dual Post Ram***

See Figure 4.

The 200-liter dual post ram delivers material from a 200-liter drum. The ram has dual pistons, controlled by a 3-position air regulator.

### ***20-Liter Dual Post Ram***

See Figure 5.

The 20-liter dual post ram delivers material from a 20 liter drum. The ram includes dual pistons. As an option, a pail hold down is available to prevent lifting up the 20-liter pail while raising the pail disk.

### ***20-Liter Single Post Ram***

See Figure 6.

The 20-liter single post ram is designed to fit into smaller spaces. The ram includes a single piston.

## ***Theory of Operation***

Ram cylinders lower the air-operated piston pump into the material drum. The rubber wipers around the outer edge of the wiper plate create a sealed compartment below the wiper plate.

The downward movement of the wiper plate forces material into the pump. The operator turns on the air pressure to the air motor, the pump strokes, and material is delivered to the dispensing device.

When the drum is empty, the operator raises the wiper plate, replaces the empty drum with a full one, and lowers the wiper plate back into the new drum.

---

### 3. Installation

---

The 58:1 QS pump system is shipped pre-assembled, bolted to a pallet, and crated or covered with a shipping carton. A Nordson representative must be present during the installation.



**WARNING:** Allow only qualified personnel to perform the following tasks. Follow the safety instructions in this document and all other related documentation.



**WARNING:** A pressurized pump is considered active even if it is not pumping. Only a pump not under pressure from the air supply is considered inactive.



**WARNING:** Comply with all applicable local, state, and national fire, electrical, and safety regulations.



**CAUTION:** Do not lift the equipment by the air motor lift ring if the total weight of the equipment exceeds 250 kg (550 lb).

## Ram Setup

See Figure 1.

Position the ram (13) so the pump air regulators (6) are easily accessible. Provide sufficient overhead clearance when the ram is fully raised. Refer to the *Specifications* section for dimensions.

1. Using the holes in the ram base as a guide, drill holes and install 13-mm (0.5-in.) anchors.
2. Level the ram in all directions. Use shims, if necessary.
3. Connect the house air line to the air input connector.
4. Set the pump air regulator and the ram air regulator (3) to 0. Make sure that the blow-off valve (2) is closed.



**CAUTION:** Use a hose support to prevent hose damage in applications where an overhead tool balancer or similar device suspends the hose. Route the hose to prevent kinking and abrasion.



**CAUTION:** Do not bend hoses sharper than a minimum bend radius of 15 cm (6 in.) diameter and do not use the hoses to pull the equipment. This may damage the hoses.

5. Connect the air and material hoses.
6. Connect the spray device or dispensing valve. Connect components to a properly grounded material hose and pump.
7. Fill the solvent cup (12) with compatible material.
8. If applicable, install and secure system guards.

---

## 4. Operation

---

Perform these steps to prepare and operate the 58:1 QS pump system.



**WARNING:** Allow only qualified personnel to perform the following tasks. Follow the safety instructions in this document and all other related documentation.



**WARNING:** Do not operate the air motor without the shield in place. Pinching or amputation of fingers or hands may occur.



**CAUTION:** Do not use a damaged container. It may damage the wiper plate or pail disk when lowered into the container.

### Ram Director Valve

See Figure 1.

The ram director valve controls the ram movement. Perform these steps to raise the ram:

1. Turn the ram director valve (4) to NEUTRAL to stop the movement of the wiper plate (10).
2. Turn the ram director valve UP to raise the wiper plate.

### Loading a New Material Container

See Figure 1.

Inspect the new material container for dents or other damage before installing.

1. Coat the wipers or pail seals with dispensing material compatible O-ring grease.
2. Place a new material container on the pump base and center the container underneath the wiper plate (10).



**WARNING:** Do not lower the wiper plate into the container without wearing goggles, gloves, and long sleeved protective clothing. Air expelled when bleeding air from the system may contain material that causes injury.

3. Open the check valve (11) and turn the ram director valve (4) DOWN to lower the wiper plate into the open container until material begins to flow from the check valve.
4. Turn the ram director valve to NEUTRAL and close the check valve.
5. Turn the ram director valve DOWN to force material into the pump (9).

**NOTE:** Make sure hoses and dispensing devices are secured firmly and that the dispensing devices are pointing away from people.

6. Open the pump bleed valve (8) to purge the remaining air.
7. Close the pump bleed valve.



**WARNING:** Do not open the pump bleed valve more than four turns. The bleed valve and material may be forced from the valve body if loosened more than four turns. Personal injury could result.

8. Adjust the pump air regulator (6) to increase pressure until the air motor (1) begins to operate.

**NOTE:** If the air motor ices up, make sure a vertical loop in the air line drop hose from the main air supply line is installed.

**NOTE:** Do not increase the pressure beyond the minimum required to cycle the pump.

## **Ram Operation**

See Figure 1.

Perform the following steps to operate the ram:

1. Close the ram air regulator (3) and the blow-off valve (2).
2. Open the remotely located main air valve, and set the ram air regulator to 4 bar (58 psi).
3. Turn the ram director valve (4) to UP and let the ram rise to its full height.



**WARNING:** Do not use damaged material containers. Rough bung openings or large dents may damage the wiper plate and seals, resulting in a runaway pump.

4. Turn the ram director valve to DOWN to lower the wiper plate (10) into the newly installed material container.
5. Turn the ram director valve to NEUTRAL to stop the wiper plate just above the container rim, and reposition the container if necessary. Open the check valve (11) on the wiper plate.

**Ram Operation** (contd)

6. Turn the ram director valve to DOWN to lower the wiper plate into the new container.
7. When material exits the check valve, stop the ram by turning the ram director valve to NEUTRAL, and close the check valve and the pump air regulator (6).
8. Set the ram air regulator to 3.5 bar (50 psi), turn the ram director valve to DOWN, and start the pump while leaving the ram director valve in the DOWN position.

**5. Maintenance**

Refer to Table 1 for recommended preventive maintenance procedures. The frequency of periodic system cleaning depends on operating conditions and shop environment.



**WARNING:** Allow only qualified personnel to perform the following tasks. Follow the safety instructions in this document and all other related documentation.



**WARNING:** To prevent injury, always relief system pressure before servicing the equipment. Trigger all dispensing devices and bleed system pressure.

Table 1 Maintenance Procedures

Frequency	Component	Maintenance Task
Daily	Entire system	Visually inspect before every shift.
	Hydraulic and pneumatic components	Check connections and tighten if necessary. Inspect tubing for bends or kinks; replace if necessary.
	Solvent cup	Check fluid level; add compatible solvent if necessary.
Weekly	Wipers	Check wipers for damage or signs of excessive material leakage. Remove material around the wipers.
	Wiper plate	Remove material accumulating on top of the wiper plate.
	Pump air regulator	Check setting and adjust air pressure if necessary.
	Ram air regulator	Check setting and adjust air pressure if necessary.
	Pump	Inspect for leaks, replace pump packing if necessary.

## Long-Term Shut Down

See Figure 1.

Perform these steps to shut down the 58:1 pump system for longer than a day:



**WARNING:** Do not lower the wiper plate into the container without wearing goggles, gloves, and long sleeved protective clothing. The air expelled when you bleed air from under the wiper plate may contain material that could cause injury.



**WARNING:** Severe personal injury could result if your hands or fingers are caught between the wiper plate and container. Keep clear of this area.

1. Remove the wiper plate (10) from the material container. Refer to the *Operation* section for more information.
2. Note the pump air regulator (6) setting. Reduce the pressure so the air motor operates slower with the solvent.
3. Note the ram air regulator setting (3). Reduce the pressure to 1–2 bar (15–30 psi) for this procedure.

## Flushing the System

See Figure 1.

Follow these steps to flush the system:

1. Carefully inspect the solvent container for dents or other damage.
2. Center the container under the wiper plate (10). Lower the wiper plate into the container.
3. When the pump (9) starts, slowly increase the air pressure to the air motor (1) until the desired flush rate is obtained.

**NOTE:** To maintain grounding continuity when flushing or relieving pressure, hold a metal part of the dispensing device firmly to the side of a grounded metal pail.

4. Trigger the dispensing device and hold it downward into an empty waste container to limit solvent over spray.
5. Pump solvent through the system until no traces of material are visible in the hose discharge.
6. Remove the solvent container and replace it with a new material container. Refer to the *Operation* section for more information.

**6. Troubleshooting**



**WARNING:** Allow only qualified personnel to perform the following tasks. Follow the safety instructions in this document and all other related documentation.

This section contains troubleshooting procedures. These procedures cover only the most common problems that you may encounter. If you cannot solve the problem with the information given here, contact your local Nordson representative for help.

**Pump**

The following table provides descriptions for common pump problems, and suggests corrective actions to solve the problem.

Problem	Possible Cause	Corrective Action
<p><b>1. Pump fails to operate</b></p>	<p>Restricted line or low air pressure</p> <p>Closed or clogged air valves</p> <p>Obstructed material hose or spray device</p> <p>Material dried on the displacement rod</p> <p>Dirty or worn air motor parts</p> <p>Air motor icing</p>	<p>Clear line and adjust air pressure. Refer to <i>Specifications</i> section for operating air pressure information.</p> <p>Clear closed or clogged air valves.</p> <p>Clear hose or spray device.</p> <p>Remove dried material. Refer to the <i>Repair</i> section for more information.</p> <p>Clean air motor parts.</p> <p>Reduce air line moisture content. Install a vertical loop in the air line drop hose from the main air supply line.</p>
<p><b>2. Low pump output on both strokes</b></p>	<p>Restricted line or low air pressure</p> <p>Closed or clogged air valves.</p> <p>Obstructed material hose or spray device</p> <p>Bleeder valve open</p> <p>Worn throat packing in displacement pump</p> <p>Air motor icing</p>	<p>Clear line and adjust air pressure. Refer to <i>Specifications</i> section for operating air pressure information.</p> <p>Clear closed or clogged air valves.</p> <p>Clear hose or spray device.</p> <p>Close bleeder valve.</p> <p>Replace the gland and the packing stack.</p> <p>Reduce air line moisture content. Install a vertical loop in the air line drop hose from the main air supply line.</p>

*Continued on next page*

Problem	Possible Cause	Corrective Action
<b>3. Low pump output on down stroke</b>	<p>Held open or worn piston valve or packing</p> <p>Air motor icing</p>	<p>Clear piston valve and replace the gland and the packing stack.</p> <p>Reduce air line moisture content. Install a vertical loop in the air line drop hose from the main air supply line.</p>
<b>4. Low pump output on up stroke</b>	<p>Held open or worn piston valve or packing</p> <p>Air motor icing</p>	<p>Clear piston valve and replace the gland and the packing stack.</p> <p>Reduce air line moisture content. Install a vertical loop in the air line drop hose from the main air supply line.</p>
<b>5. Erratic or accelerated pump speed</b>	<p>Exhausted material supply</p> <p>Held open or worn piston valve or packing</p> <p>Held open or worn priming piston</p> <p>Worn throat packing in displacement pump</p> <p>Air motor icing</p>	<p>Refill and prime the system.</p> <p>Clear piston valve and replace the gland and the packing stack.</p> <p>Clear priming piston and service the piston.</p> <p>Replace the gland and the packing stack.</p> <p>Reduce air line moisture content. Install a vertical loop in the air line drop hose from the main air supply line.</p>

**Air Motor**

The following table provides descriptions for common air motor problems, and suggests corrective actions to solve the problem.



**WARNING:** Moving parts can pinch or amputate fingers or other body parts. To reduce the risk of serious injury, keep fingers and other body parts away from moving parts.

Problem	Possible Cause	Corrective Action
<b>1. Air leak, (stroke position UP only, air valve housing down)</b>	Blown air manifold gasket	Detect by feel. Replace the air manifold gasket.
	Blown air cylinder gasket	Detect by feel. Replace the air cylinder gasket.
	Worn throat packing	Detect by squirting oil around the wiper seal. Replace the throat packing.
<b>2. Stalled motor</b>	Frozen valve, air motor icing	Make sure a vertical loop in the air line drop hose from the main air supply line is installed. Shut motor off and allow ice to thaw.
	Broken trip rod spring	Replace trip rod spring.
<b>3. Air leak</b>	Worn or damaged hoses, loose connections	Shut off the air supply and disconnect the air hose. See Figure 2. Remove the nipple (30). Remove the shield (3) and screw the nipple back into the manifold. Connect the air hose and turn the air on. Do not exceed an input air pressure of 2.8 bar (40 psi)
<b>4. Air leak, (stroke position DOWN only, air valve housing up)</b>	Blown air manifold gasket	Detect by feel. Replace the air manifold gasket.
	Damaged wiper seal	Detect by feel. Replace the wiper seal.
	Damaged trip rod bearing gasket	Detect by squirting oil around the wiper seal. Replace trip rod bearing gasket.
<b>5. Air leak, (stroke position UP, air valve housing down) and stroke position DOWN, air valve housing up)</b>	Worn air valves or O-rings	Detect by squirting oil around the air valve housing. Replace air valves or O-rings.
	Worn piston O-ring	Detect by holding paper strip over the exhaust holes. Replace piston O-ring.

**Ram**

The following procedures cover only the most common problems that you may encounter with your ram. If you cannot solve the problem with the information given here, contact your Nordson representative.

<b>Problem</b>	<b>Possible Cause</b>	<b>Corrective Action</b>
<b>1. Ram will not raise or lower</b>	Closed air valve or clogged air line	Clear the air line, and increase the air supply. Check that the valves are open.
	Not enough air pressure to ram	Increase the air pressure. Do not exceed 10 bar (150 psi).
	Worn or damaged piston	Service the piston. Contact your Nordson representative.
	Director valve closed or clogged	Open and clear the valve.
<b>2. Ram raises and lowers too fast</b>	Air pressure to ram too high	Decrease the air pressure.
<b>3. Material leaks past the wiper</b>	Air pressure to ram too high	Decrease the air pressure.
	Worn or damaged wipers	Replace the wipers.
<b>4. Pump will not prime properly or pumps air</b>	Closed air valve or clogged air line	Clear the air line and increase the air pressure.
	Not enough air pressure to ram	Increase the air pressure. Do not exceed 10 bar (150 psi).
	Worn or damaged piston	Service the piston. Contact your Nordson representative.
	Director valve clogged or closed	Open or clear the director valve.
	Director valve dirty, worn, or damaged	Service or clean the director valve.
	Wiper plate check valve open	Close the check valve.
<b>5. Air director valve will not hold container down or lift plate up</b>	Closed air valve or clogged air line	Clear the air line and increase the air supply. Check that the valves are open.
	Not enough air pressure to ram	Increase the air pressure. Do not exceed 10 bar (150 psi).
	Valve passage clogged	Clean the valve.

### ***Air Motor Icing***

Moisture in the compressed air can collect in the air motor and freeze, causing the motor to stall.

If icing occurs, shut off the air supply and allow the ice to thaw. To minimize icing, reduce the moisture in your compressed air supply by using an air dryer or filter that traps water.

The main air line should slope slightly downward so that water will collect at the end of the line where it can be drained. In addition, plumb a drop line from the top of each main air line. Install an automatic drain or drain valve at the bottom of each drop.

---

## 7. Repair

---

This section describes repair procedures for the 58:1 QS pump system.



**WARNING:** Allow only qualified personnel to perform the following tasks. Follow the safety instructions in this document and all other related documentation.



**WARNING:** System or material pressurized. Relieve pressure. Failure to observe may result in serious injury.



**WARNING:** Wear protective clothing, goggles, and gloves when working with this equipment.



**WARNING:** To reduce the risk of serious bodily injury, including injection, splashing in the eyes, or injury from moving parts, always follow the pressure relief procedure when checking or servicing the 58:1 QS pump.

### **Pressure Relief**

See Figure 1.

Perform these steps to relief pressure from the 58:1 QS pump system:

1. Shut off the main air and close the air motor on/off valve (5).
2. Disengage the dispensing gun safety latch, if applicable.
3. Hold a metal part of the dispensing gun firmly to the side of a grounded metal pail and trigger the dispensing gun to relieve pressure.
4. Open the pump bleed valve (8).
5. If you suspect that the dispensing nozzle or the hose is completely clogged, or that pressure has not been fully relieved, slowly loosen the dispensing nozzle retaining nut or the dispensing gun hose coupling and relieve pressure gradually.

## Air Motor Disassembly

Perform these steps to disassemble the air motor:

**NOTE:** For best results, use all the new parts in the repair kit. Refer to the *Parts* section for repair kit components.

### Removing the Air Motor from the Ram

See Figure 2.

1. Remove the air supply hose and the mounting bracket screws. Remove the air motor from the ram.
2. Place the air motor on a workbench and remove the ring (1), washer (2), and nipple (30).
3. Remove the air motor shield (3), cover (4), filter (5), and filter cover (6).

### Disassembling the Housing

See Figure 2.

1. Unscrew the retainer (14) and remove the spring (13), spring guide (12) and plunger (11) from each side of the housing (9).
2. Remove the bolts (7) and spring washers (8) from the housing. Carefully lift the housing so the axles (10) do not fall out. Remove the axles, pad washer (16), and pad (15).

**NOTE:** Do not let the spring-loaded valve (23) jump out of the housing (19).

3. Lift the housing and rotate it 90 degrees, so it rests on the manifolds (27, 29). Remove your fingers slowly, allowing the spring (20) to release gently. Remove and inspect the spring-loaded valve, the O-ring (22), the washers (21), and the springs.



**WARNING:** The openings in the valve plates are very sharp. Handle with care. Failure to observe may result in personal injury.

4. Remove the manifolds (27, 29) along with the tube (53).



**CAUTION:** Do not damage the trip rod surface. A damaged trip rod can not be repaired and must be replaced.

### ***Disassembling the Air Motor Base***

See Figure 2.

1. Pull the trip rod (48) up. Hold the flats of the trip rod with a wrench, screw off the trip rod nuts (17, 18), and remove the housing (9).
2. Remove the pad (15) and pad washer (16) from the body (34). Remove the bolts (31) and spring washers (32) from the manifolds (27, 29), and remove the manifolds.
3. Remove the screws (24). Remove and check the valve plates (25, 28) and the gaskets (26) for wear or damage. Clean the valve plates and mating surfaces.

**NOTE:** When replacing the valve plates, also replace the gaskets (26).

4. Remove the nuts (35), spring washers (36), washers (37), and body.
5. Pull the piston (47), and the trip rod (48) out of the cylinder (43) and the base (56). Remove the O-ring (46) from the piston.
6. Turn the base over and remove the screw (42). Remove the retainer (41), O-ring (40), and the U-ring packing (39).

### ***Final Disassembly***

See Figure 2.

1. Lock the flats of the piston rod (49) in a vise. Remove the bolts (44) and the hub (45).

**NOTE:** A damaged trip rod cannot be repaired. Use a new trip rod.

2. Remove the trip rod (48) from the piston (47).
3. Remove the U-packing (50) and the washer (51). Remove the tubes (53), bolts (54), and O-rings (52). Remove the cylinder (43) and the O-rings (38).
4. Turn the base over and remove the ring (62). Remove the V-packing stack (61). Inspect the bearing in place. Replace base if damaged.
5. Remove tie rods (59, 60).

## Air Motor Assembly

Clean all parts thoroughly and inspect for wear or damage. Replace worn parts. Perform these steps to assemble the air motor:

### Assembling the Air Motor Base

See Figure 2.

Perform these steps to assemble the air motor base:

1. Install the tie rods (59, 60). With the base (56) turned over, insert the V-packing stack (61) and install the ring (62).
2. Turn the base over, grease and install the O-ring (38). Carefully lower the cylinder (43) onto the body (34).
3. Install the washer (51) and the U-packing (50). Install the bolts (54), tubes (53), and O-rings (52).
4. Install the trip rod (48) to the piston (47).

**NOTE:** Apply Loctite 242 or the equivalent to the piston and connecting rod threads before screwing the hub (45) into the piston (47).

5. Install the hub (45) and tighten to 203 N•m (150 ft-lb). Insert the bolts (44) into the hub and tighten to 27–34 N•m (20–25 ft-lb).
6. Turn the base over and install the U-packing (39), O-ring (40), and retainer (41). Secure the retainer with the screws (42).
7. Lubricate and install the O-ring (46). Insert the piston rod (49) and the trip rod (48) into the cylinder (43).



**CAUTION:** Do not damage the polished surfaces of the trip rod and the piston rod during assembly.

8. Grease and install the O-ring (38). Install the body (34), washers (37), spring washers (36) and nuts (35).
9. Pull the trip rod up, and install the housing (9). Hold the flats of the trip rod with a wrench and install the nuts (17, 18).

### ***Assembling the Housing***

See Figure 2.

Perform these steps to assemble the housing:

1. Install the gaskets (26) and plates (25, 28) to the manifolds (27, 29), secure the plates with the screws (24).
2. Install the pad (15) and pad washer (16). Grease and install the O-ring (33) to the manifold (27).
3. Grease and install the O-rings (52) to the tube (53). Install both manifolds (27, 29) to the body (34).
4. Install the spring washers (32) and secure the manifold with the bolts (31).
5. Place the spring (20), washer (21), O-ring (22), and spring-loaded valve (23) into the housing (19). Hold the spring-loaded valve with your fingers to prevent it from popping out.
6. Rotate the housing, place it between the manifolds (27, 29). Insert the bolts (7) and spring washers (8). Tighten the bolts.
7. Insert the axle (10), plunger (11), spring guide (12), and spring (13). Screw in the retainer (14).
8. Install the filter (5), the filter cover (6), the cover (4), the shield (3), the washer (2), the ring (1) and the nipple (30).

### ***Installing the Air Motor to the Ram***

Perform these steps to install the air motor to the ram:

1. Place the air motor on the ram mounting bracket and secure it with the screws.
2. Attach a supply hose to the nipple and run the air motor slowly to check for smooth operation.

## **Pump Disassembly**

Flush the system with a compatible solvent and disconnect all hoses before disassembling the pump. Remove the air motor before removing the pump section. Refer to the *Air Motor* section for more information.

### **Removing the Pump from the Air Motor**

See Figure 3.

Perform these steps to remove the pump from the air motor:

1. Unscrew the nut (2) and remove the collar (3).
2. Unscrew and remove the connecting rods (4, 5).
3. Remove the solvent cup (6) and the O-ring (7).

**NOTE:** If you are using a repair kit to service the pump, use all the new parts. Refer to the *Parts* section for kit information.

4. Pull the pump away from the air motor. Place the pump housing (22) in a vise with padded jaws. Remove the outlet adapter (21) and the O-ring (20). Remove the bleed valve assembly (19).
5. Remove the solvent cup packing nut (8), and the packing nut (13). Remove the V-packings (10, 11), male gland (12) and female gland (9) from the packing nut (13).
6. Remove the packing nut, O-ring (14), cylinder nut (15), and tie plate (16).
7. Push the displacement rod (23) down so that the priming piston (43) clears the intake cylinder (39).
8. Use two wrenches to oppositely turn and loosen the two hex nuts (40) on the piston rod (30).
9. Remove the valve check plate (41), valve guide (42), and the priming piston.

### **Final Disassembly**

See Figure 3.

Perform these steps to completely disassemble the pump:

1. Remove the intake valve cylinder (39) and the O-ring (38).
2. Pull on the piston rod to remove the displacement rod from the pump housing.
3. Remove the cotter pin (28) and thread the piston rod from the piston valve (29).
4. Remove the packing nut (33) from the piston rod. Remove the V-packings and female gland (34, 35, 36).



**CAUTION:** Be careful not to drop or lose the piston ball (25).

5. Unscrew the piston valve from the piston valve housing (24).
6. Remove the male gland (12), packing (10, 11), washer (26) and female gland (27).
7. Remove the pump cylinder (31) and O-rings (14).
8. Inspect the outer surface of the displacement rod (23) and the inner surface of the pump cylinder for scoring and wear by holding them up to a light or running a finger over the surface. Replace these parts if necessary.

**NOTE:** If the displacement rod is worn, the V-packing will not seal properly and the pump will leak. If the pump cylinder is worn, the pump will not stall against pressure.

9. Clean all parts in a compatible solvent. Inspect all parts and replace them if necessary.

## **Pump Assembly**

Lubricate all pump components with a compatible lubricant. Perform these steps to assemble the pump:

### ***Assembling the Pump Housing***

See Figure 3.

Perform these steps to assemble the pump:

1. Place the tie plate (16) on the pump housing (22) and tighten the cylinder nut (15).
2. Install the bleeder valve assembly (19), the O-ring (20), and the outlet adapter (21).
3. Place the O-ring (14) on the packing nut (13). Screw the packing nut into the pump housing.
4. Place the first pre-assembled V-packing stack (9, 10, 11,12) into the packing nut (13). Be sure that the lips of the V-packing stack are facing down.
5. Place the O-ring (7) in the groove of the solvent cup packing nut (8). Loosely install the solvent cup packing nut and the solvent cup (6) into the pump housing.
6. Install the second pre-assembled V-packing stack (10, 11), male gland (12), and female gland (27) on the piston valve (29) with the lips of the V-packings facing up.
7. Install the washer (26) on top of the second V-packing stack, and install the piston ball (25) in the piston valve housing (24).
8. Apply medium grade thread sealant to the threads of the piston valve and piston valve housing, and screw the piston valve into the piston valve housing. Tighten to 81–102 N•m (60–76 ft-lb).
9. Screw the piston rod (30) into the piston valve and align the holes to insert the cotter pin (28).

### **Final Pump Assembly**

See Figure 3.

Perform these steps to completely assemble the pump:

1. Place the pump housing (22) in a vise. Install the new O-rings (14) on the pump cylinder (31). Lubricate the cylinder and slide it into the pump housing as far as possible.
2. Slide the rod guide (32) onto the piston rod, with the flat side facing down, and install the displacement rod assembly through the bottom of the pump, guiding it carefully through the throat packings..
3. Install the third pre-assembled, V-packing stack (34, 35, 36) into the valve housing (37). Be sure that the lips of the V-packings are facing up. Install the packing nut (33) and tighten to 34–47 N•m (25–35 ft-lb). Slide the assembly (packing nut first) onto the piston rod.
4. Place the O-ring (38) around the intake valve cylinder (39). Screw the cylinder into the pump housing. Tighten to 129–149 N•m (94–110 ft-lb).
5. Thread the nut (40) onto the bottom of the piston rod. Install the check valve plate (41), valve guide (42), priming piston (43), and the nut (40).
6. Hold the upper nut (40) while tightening the bottom nut to 54–81 N•m (40–60 ft-lb).
7. Tighten the packing nut (33). Tighten the solvent cup packing nut (8) to 54–81 N•m (40–60 ft-lb).
8. Thread the connecting rods (4, 5) into the displacement rod (23); install the collar (3); and tighten the nut (2) to reconnect the pump to the air motor (1).

**NOTE:** Contact your Nordson representative to verify that you are choosing the correct type of solvent cup material for your application.

9. Fill the solvent cup (6) with Nordson K-solvent or a solvent compatible with the material being pumped.
10. Bleed the pump.

### **Ram Piston Rod Packing Disassembly**

See Figure 4.

Before disassembling the ram piston rod, tighten the nut (5) to stop air from leaking from the piston. If air continues to leak from the piston, perform these steps to disassemble and service the ram piston rod packing:

1. Relieve the pressure and remove the nuts (1) and lock washers (2).
2. Remove the beam (3).
3. Remove the nut (5) from the tie rod (14), remove the housing (12), and slide it up and off the tie rod (14).
4. Remove the bearing (6), the female gland (7), the V-packings (9, 10), the male gland (8), the housing (12), and the seal (13).
5. Inspect the parts for wear or damage. Replace if necessary.

### **Ram Piston Rod Packing Assembly**

See Figure 4.

Perform these steps to assemble the piston rod packing:

1. Install the seal (13) and housing (12). Slide the male gland (8) onto the tie rod (14).
2. Lubricate the V-packings (9, 10) and slide them onto the tie rod one at a time, with the lips facing down.
3. Slide the female gland (7) onto the tie rod and push all of the packings into the housing (12). Slide the bearing (6) onto the tie rod.



**CAUTION:** Do not over tighten. You could damage the V-packings.

4. Slide the nut (5) onto the tie rod; screw it onto the housing; and hand-tighten.
5. Reinstall the beam (3) on the tie rods and piston rods (18) using the nuts (1) and the lockwashers (2).

**Ram Piston Disassembly**

See Figure 4.

Perform these steps to disassemble the piston:

1. Relieve the system air pressure.
2. Remove the nut (1) and lock washer (2). Remove the beam (3). Refer to *Piston Rod Packing Replacement* for more information.
3. Remove the cap (4) from the tie rod (14). Loosen the nut (5) and slide the nut, bearing (6), and housing (12) up off the tie rod.



**CAUTION:** If the tie rod is cocked to one side, the piston or inside surface of the air cylinder could be damaged.

4. Carefully pull the tie rod and piston (22) straight up out of the ram base and air cylinder (40).
5. Carefully lay the piston and the tie rod down on a workbench. Remove the nut (25), washer (24), piston cap (23), U-packing (21), piston bushing (16), piston, washer (19) and spring (15).
6. Inspect the parts for wear or damage. Replace if necessary.

**Ram Piston Assembly and Installation**

See Figure 4.

Perform these steps to assemble and install the ram piston into the ram:

1. Install the O-ring (20) to the piston (22) and lubricate both with grease.
2. Install the spring (15), washer (19), the piston, piston bushing (16), U-packing (21), piston cap (23), washer (24), and nut (25). Tighten the nut.



**CAUTION:** Do not over tighten. You may damage the packing.

3. Carefully insert the piston and the tie rod (14) into the ram base and air cylinder (40). Push the tie rod straight down into the cylinder. Slide the housing (12), bearing (6), and nut (5) down onto the tie rod and hand-tighten.
4. Install the cap (4) and the beam (3). Install the lockwashers (2) and the nuts (1).

**8. Parts**

To order parts, call the Nordson Customer Service Center or your local Nordson representative. Use the parts list, and the accompanying illustration, to describe and locate parts correctly.

**Using the Illustrated Parts List**

Numbers in the Item column correspond to numbers that identify parts in illustrations following each parts list. The code NS (not shown) indicates that a listed part is not illustrated. A dash (—) is used when the part number applies to all parts in the illustration.

The number in the Part column is the Nordson Corporation part number. A series of dashes in this column (-----) means the part cannot be ordered separately.

The Description column gives the part name, as well as its dimensions and other characteristics when appropriate. Indentions show the relationships between assemblies, subassemblies, and parts.

Item	Part	Description	Quantity	Note
—	000 0000	Assembly	1	
1	000 000	• Subassembly	2	A
2	000 000	• • Part	1	

- If you order the assembly, items 1 and 2 will be included.
- If you order item 1, item 2 will be included.
- If you order item 2, you will receive item 2 only.

The number in the Quantity column is the quantity required per unit, assembly, or subassembly. The code AR (As Required) is used if the part number is a bulk item ordered in quantities or if the quantity per assembly depends on the product version or model.

Letters in the Note column refer to notes at the end of each parts list. Notes contain important information about usage and ordering. Special attention should be given to notes.

**Top Level Assemblies**

Refer to Table 2 for a list of QS 58:1 top level assemblies and their Nordson part numbers:

Table 2 Top Level Assemblies

Top Level Assembly	Nordson Part Number
58:1 pump, (20 liter), dual post, with hold down	320 884
58:1 pump, (20 liter,) dual post, no hold down	320 885
58:1 pump, (20 liter,) single post, with hold down	320 887
58:1 pump, (20 liter), single post, no hold down	320 886
58:1 pump, (200 liter), dual post	320 892

**Air Motor**

See Figure 2.

Item	Part	Description	Quantity	Note
—	Q-607 647	Assembly, air motor, 10-in.	1	
1	Q-260 101	• Ring	1	
2	Q-260 102	• Washer	4	
3	Q-260 103	• Shield	2	
4	Q-260 104	• Cover	1	
5	Q-260 105	• Filter	1	
6	Q-260 106	• Filter cover	1	
7	Q-260 107	• Bolt	4	
8	Q-260 108	• Spring washer	4	
9	Q-260 109	• Housing	1	
10	Q-260 110	• Axle	2	
11	Q-260 111	• Plunger	2	
12	Q-260 112	• Spring guide	4	
13	Q-260 113	• Spring	2	
14	Q-260 114	• Retainer	2	
15	Q-260 115	• Pad	2	
16	Q-260 116	• Pad washer	2	
17	Q-260 117	• Nut	1	
18	Q-260 118	• Nut	2	
19	Q-260 119	• Housing	1	
20	Q-260 120	• Spring	1	
21	Q-260 121	• Washer	1	

*Continued on next page*

**Air Motor** (contd)

Item	Part	Description	Quantity	Note
22	Q-260 122	• O-ring	2	
23	Q-260 123	• Valve	1	
24	Q-260 124	• Screw	8	
25	Q-260 125	• Plate	1	
26	Q-260 126	• Gasket	2	
27	Q-260 127	• Manifold	1	
28	Q-260 128	• Plate	1	
29	Q-260 129	• Manifold	1	
30	Q-260 130	• Nipple	1	
31	Q-260 131	• Bolt	1	
32	Q-260 132	• Spring washer	1	
33	Q-260 133	• O-ring	2	
34	Q-260 134	• Body	1	
35	Q-260 135	• Nut	4	
36	Q-260 136	• Spring washer	8	
37	Q-260 137	• Washer	4	
38	Q-260 138	• O-ring	2	
39	Q-260 139	• U-packing	1	
40	Q-260 140	• O-ring	1	
41	Q-260 141	• Retainer	1	
42	Q-260 142	• Screw	3	
43	Q-260 143	• Cylinder	1	
44	Q-260 144	• Bolt	3	
45	Q-260 145	• Hub	1	
46	Q-260 146	• O-ring	1	
47	Q-260 147	• Piston	1	
48	Q-260 148	• Trip-rod	1	
49	Q-260 149	• Piston rod	1	
50	Q-260 150	• U-packing	1	
51	Q-260 151	• Washer	1	
52	Q-260 152	• O-ring	2	
53	Q-260 153	• Tube	1	

*Continued on next page*

Item	Part	Description	Quantity	Note
54	Q-260 154	• Bolt	4	
55	Q-260 155	• Plate	1	
56	Q-260 156	• Base	1	
57	Q-260 157	• Screw	12	
58	Q-260 158	• Plate	1	
59	Q-260 159	• Tie rod $\frac{5}{8}$ x 250	3	
60	Q-260 160	• Tie rod $\frac{5}{8}$ x 301.5	3	
61	Q-260 161	• Assembly, packing	1	
63	-----	• • Gland, female	2	
64	-----	• • V-packing	2	
65	-----	• • V-packing	2	
66	-----	• • Gland, male	1	
62	Q-260 162	• Ring	1	

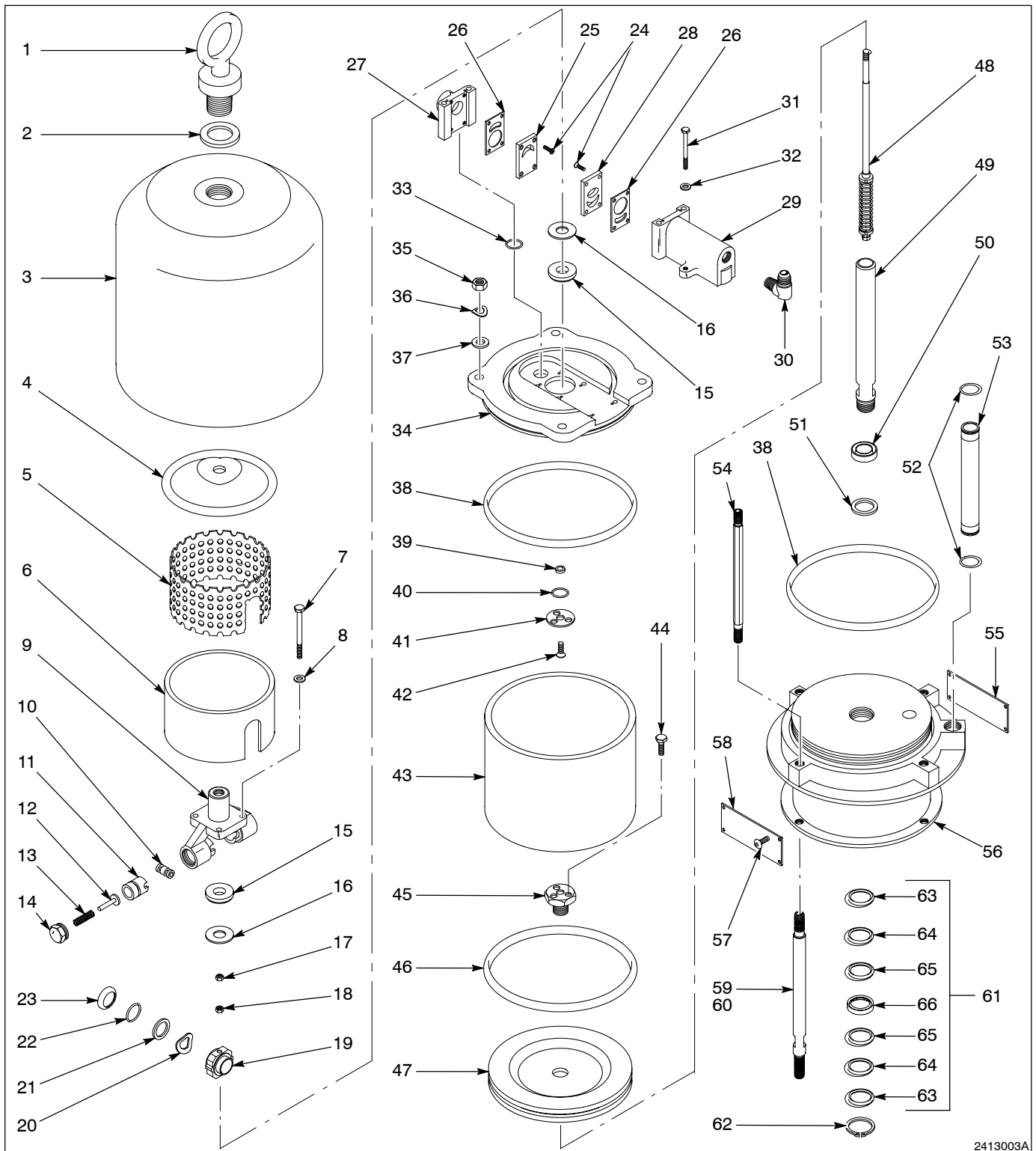

2413003A

Fig. 2 Air Motor Parts

**Air Motor Repair Kit**

See Figure 2.

Item	Part	Description	Quantity	Note
—	Q-320 914	QS air motor 58:1 repair kit, packaged	1	
20	Q-260 120	• Spring	1	
21	Q-260 121	• Washer	1	
22	Q-260 122	• O-ring	2	
23	Q-260 123	• Valve	1	
33	Q-260 133	• O-ring	2	
38	Q-260 138	• O-ring	2	
39	Q-260 139	• U-packing	1	
40	Q-260 140	• O-ring	1	
46	Q-260 146	• O-ring	1	
50	Q-260 150	• U-packing	1	
51	Q-260 151	• Washer	1	

**Pump**

See Figure 3.

Item	Part	Description	Quantity	Note
1	Q-607 647	Air motor assembly	1	
—	Q-581-639	Pump, hydraulic assembly	1	
2	Q-581 101	• Nut, 1 1/4-12 thread	1	
3	Q-581 102	• Collar	2	
4	Q-581 103	• Connecting rod, 3/4 x 63.5 in.	1	
5	Q-581 104	• Connection rod, 3/4 x 115 in.	1	
6	Q-581 105	• Cup, solvent	1	
7	Q-581 106	• O-ring, Viton	1	
8	Q-581 107	• Nut, packing, solvent cup	1	
9	Q-581 108	• Gland female	1	
10	Q-581 109	• V-packing, PTFE	6	
11	Q-581 110	• V-packing, ultrahigh molecular weight polyethylene	6	
12	Q-581 111	• Gland, male	2	
13	Q-581 112	• Nut, packing	1	
14	Q-581 113	• O-ring, PTFE	3	
15	Q-581 114	• Nut, cylinder M80	1	
16	Q-581 115	• Plate, tie	1	
19	Q-581 118	• Bleed valve assembly	1	
17	Q-581 116	• Plug, bleeder valve	1	
18	Q-581 117	• Body, bleeder valve	1	
20	Q-581 119	• O-ring, Viton	1	
21	Q-581 120	• Adapter, outlet M39 x 1 in. NPT	1	
22	Q-581 121	• Housing, pump	1	
23	Q-581 122	• Rod, displacement	1	
24	Q-581 123	• Housing, valve, piston	1	
25	Q-581 124	• Ball, piston	1	
26	Q-581 125	• Washer	1	
27	Q-581 126	• Gland, female	1	
28	Q-581 127	• Pin, cotter	1	
29	Q-581 128	• Valve, piston	1	
30	Q-581 129	• Rod, piston	1	
31	Q-581 130	• Cylinder, pump	1	

*Continued on next page*

Item	Part	Description	Quantity	Note
32	Q-581 131	• Guide, rod	1	
33	Q-581 132	• Nut, packing	1	
34	Q-581 133	• V-packing, ultrahigh molecular weight polyethylene	3	
35	Q-581 134	• V-packing, PTFE	1	
36	Q-581 135	• Gland, female	1	
37	Q-581 136	• Valve, piston	1	
38	Q-581 137	• O-ring, PTFE	1	
39	Q-581 138	• Cylinder, valve, intake	1	
40	Q-581 139	• Nut, machine, hex, M16	2	
41	Q-581 140	• Plate, valve, check	1	
42	Q-581 141	• Guide, valve	1	
43	Q-581 142	• Piston, priming	1	

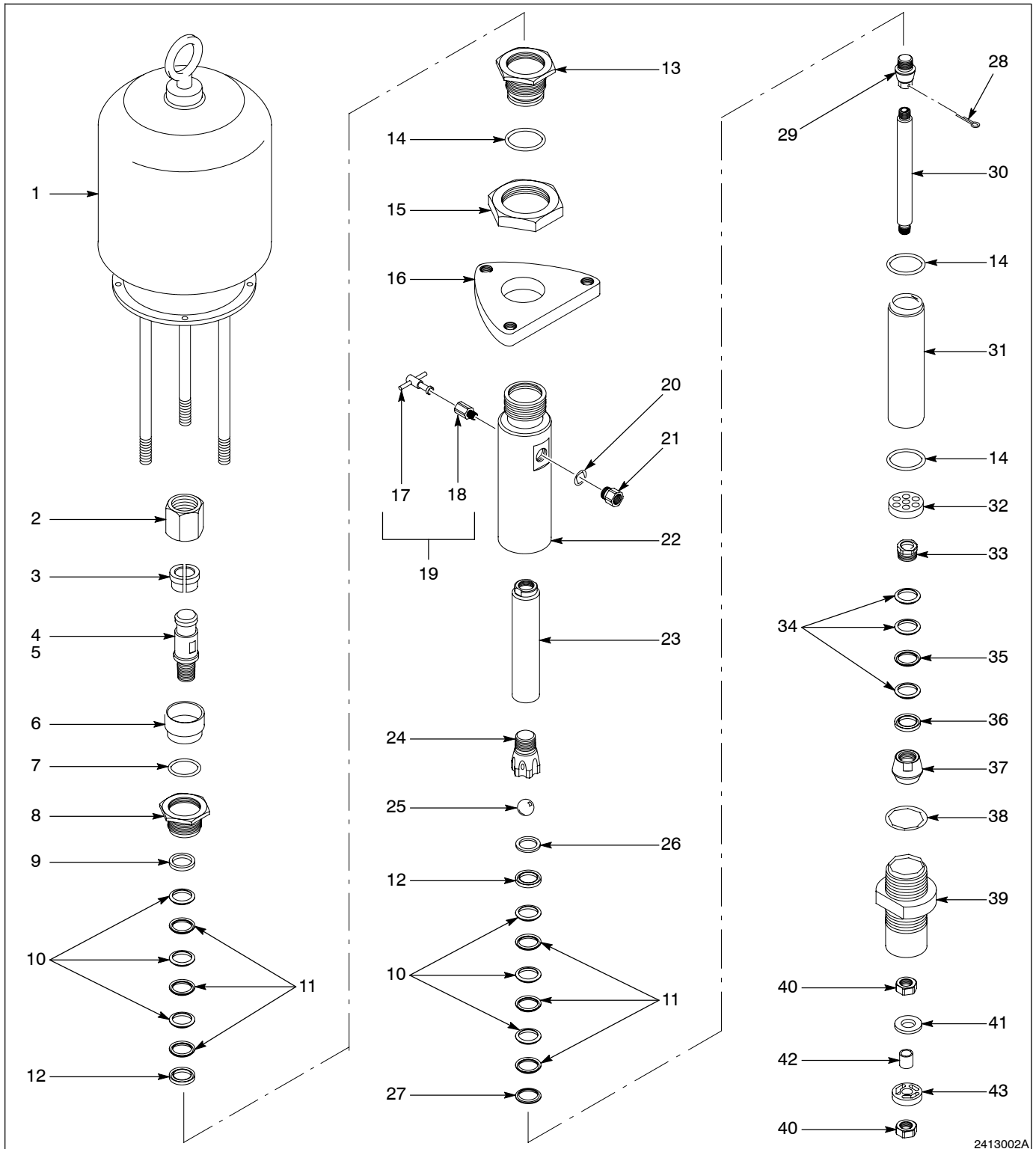

2413002A

Fig. 3 Pump Parts

**Pump Repair Kit**

See Figure 3.

Item	Part	Description	Quantity	Note
—	320 915	Pump repair kit	1	
7	Q-581 106	• O-ring, Viton	1	
9	Q-581 108	• Gland female	1	
10	Q-581 109	• V-packing, PTFE	6	
11	Q-581 110	• V-packing, ultrahigh molecular weight polyethylene	6	
12	Q-581 111	• Gland, male	2	
14	Q-581 113	• O-ring, PTFE	3	
25	Q-581 125	• Ball, piston	1	
26	Q-581 125	• Washer	1	
27	Q-581 126	• Gland, female	1	
34	Q-581 133	• V-packing, ultrahigh molecular weight polyethylene	3	
35	Q-581 134	• V-packing, PTFE	1	
36	Q-581 135	• Gland, female	1	
38	Q-581 137	• O-ring, PTFE	1	

**200-Liter Dual Post Ram**

See Figure 4.

Item	Part	Description	Quantity	Note
—	-----	Assembly, 200-liter dual post ram	1	
1	Q-550 201	• Nut	4	
2	Q-550 202	• Washer, lock	4	
3	Q-550 203	• Beam	1	
4	Q-550 204	• Cap	2	
5	Q-550 205	• Nut	2	
6	Q-550 206	• Bearing	2	
7	Q-550 207	• Gland, female	2	
8	Q-550 208	• Gland, male	2	
9	Q-550 209	• V-packing, PTFE	4	
10	Q-550 210	• V-packing	4	
11	Q-407 652	• Kit, regulator	1	
12	Q-550 211	• Housing	1	
13	Q-550 212	• Seal	2	
14	Q-550 213	• Rod, tie	2	
15	Q-550 214	• Spring	2	
16	Q-550 215	• Bushing, piston	2	
18	Q-550 217	• Rod	2	
19	Q-550 219	• Washer	2	
20	Q-550 220	• O-ring	2	
21	Q-550 221	• U-packing	4	
22	Q-550 222	• Piston	2	
23	Q-550 223	• Cap, piston	2	
24	Q-550 247	• Washer, lock	2	
25	Q-550 228	• Nut	2	
26	Q-550 229	• Screw	4	
27	Q-550 230	• Washer, lock	4	
28	Q-550 233	• Bracket	1	
29	Q-550 234	• Nut	2	
30	Q-550 231	• Screw	4	
31	Q-550 235	• Washer, lock	2	
32	Q-550 237	• Bracket	2	

*Continued on next page*

Item	Part	Description	Quantity	Note
33	Q-550 238	• Union	1	
34	Q-550 240	• Nipple	1	
35	Q-550 241	• Valve, ball	1	
36	Q-550 242	• Plug	1	
37	Q-550 243	• Plate, inductor	1	
38	Q-550 244	• Wiper, upper	1	
39	Q-550 245	• Wiper, lower	1	
40	Q-550 246	• Ram base and air cylinder	1	
41	Q-550 248	• Assembly, air director valve	1	
42	Q-550 249	• Assembly, seal retainer	1	
43	Q-550 280	• Hose	1	
44	Q-550 239	• Hose, tube	1	
45	Q-550 250	• Assembly, wiper ring	1	
46	Q-550 247	• Coupling	1	

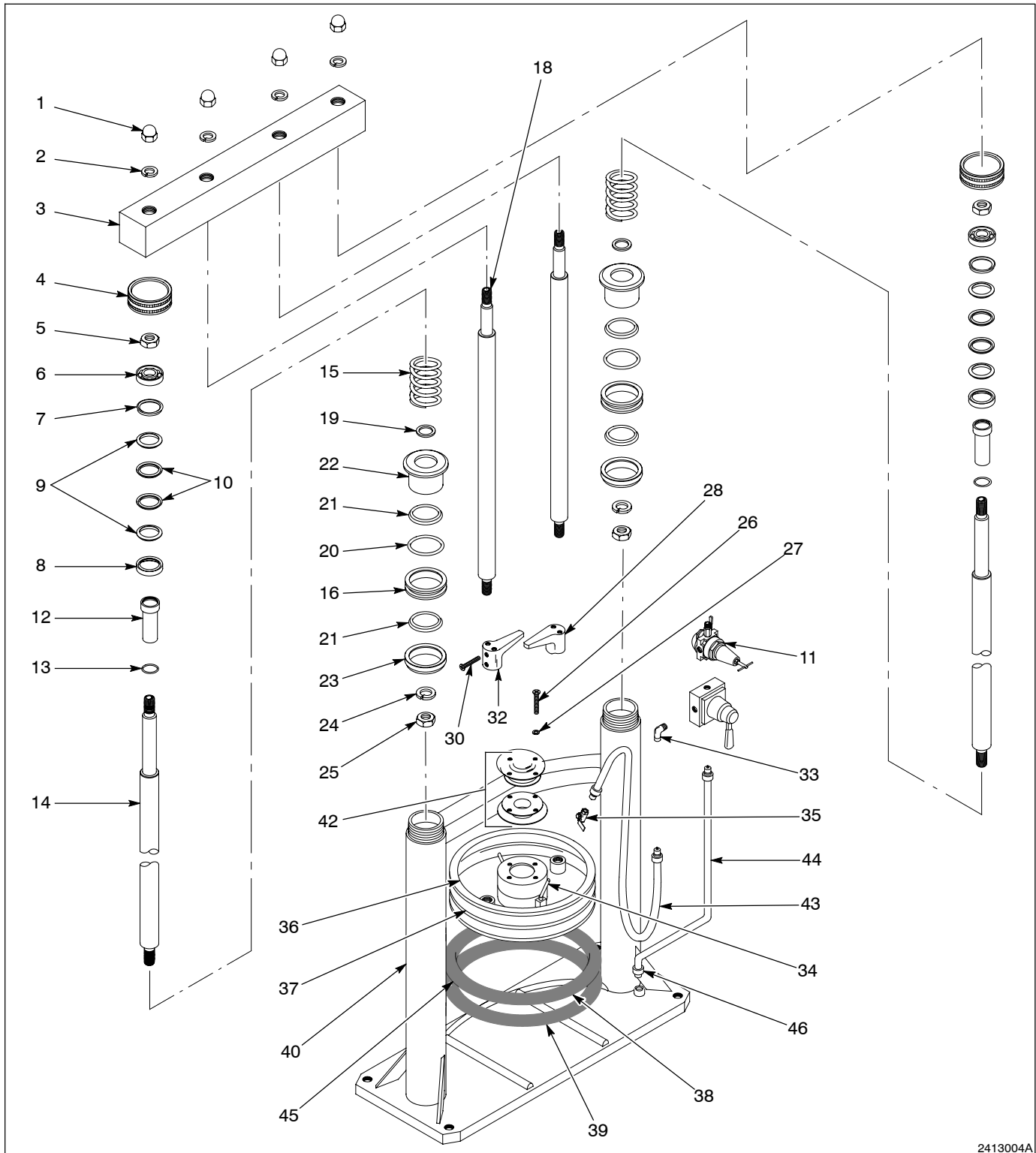

2413004A

Fig. 4 200-Liter Dual Post Ram

**200-Liter Dual Post Ram**

See Figure 4.

<b>Item</b>	<b>Part</b>	<b>Description</b>	<b>Quantity</b>	<b>Note</b>
—	320 918	Kit, repair, 200-liter, dual post	1	
7	Q-550 207	• Gland, female	2	
8	Q-550 208	• Gland, male	2	
9	Q-550 209	• V-packing, PTFE	4	
10	Q-550 210	• V-packing	4	
20	Q-550 220	• O-ring	2	
21	Q-550 221	• U-packing	4	

**20-Liter Dual Post Ram**

See Figure 5.

Item	Part	Description	Quantity	Note
—	-----	Assembly, 20-liter dual post ram	1	
1	Q-580 101	• Nut, cap	2	
2	Q-580 102	• Washer, spring	4	
3	Q-580 103	• Base, pump	1	
4	Q-580 104	• Cap	2	
5	Q-580 105	• Seal	2	
6	Q-580 106	• Cover	2	
7	Q-580 107	• U-packing	2	
8	Q-580 108	• Ring, wear	4	
9	Q-580 109	• O-ring	2	
10	Q-580 110	• Rod, piston	2	
11	Q-580 111	• Washer	2	
12	Q-580 112	• Spring	2	
13	Q-580 113	• Piston	2	
14	Q-580 114	• U-packing	2	
15	Q-580 115	• O-ring	2	
16	Q-580 116	• Piston bushing	2	
17	Q-580 117	• Cap, piston	2	
18	Q-580 118	• Nut	2	
19	Q-580 119	• Ram	1	

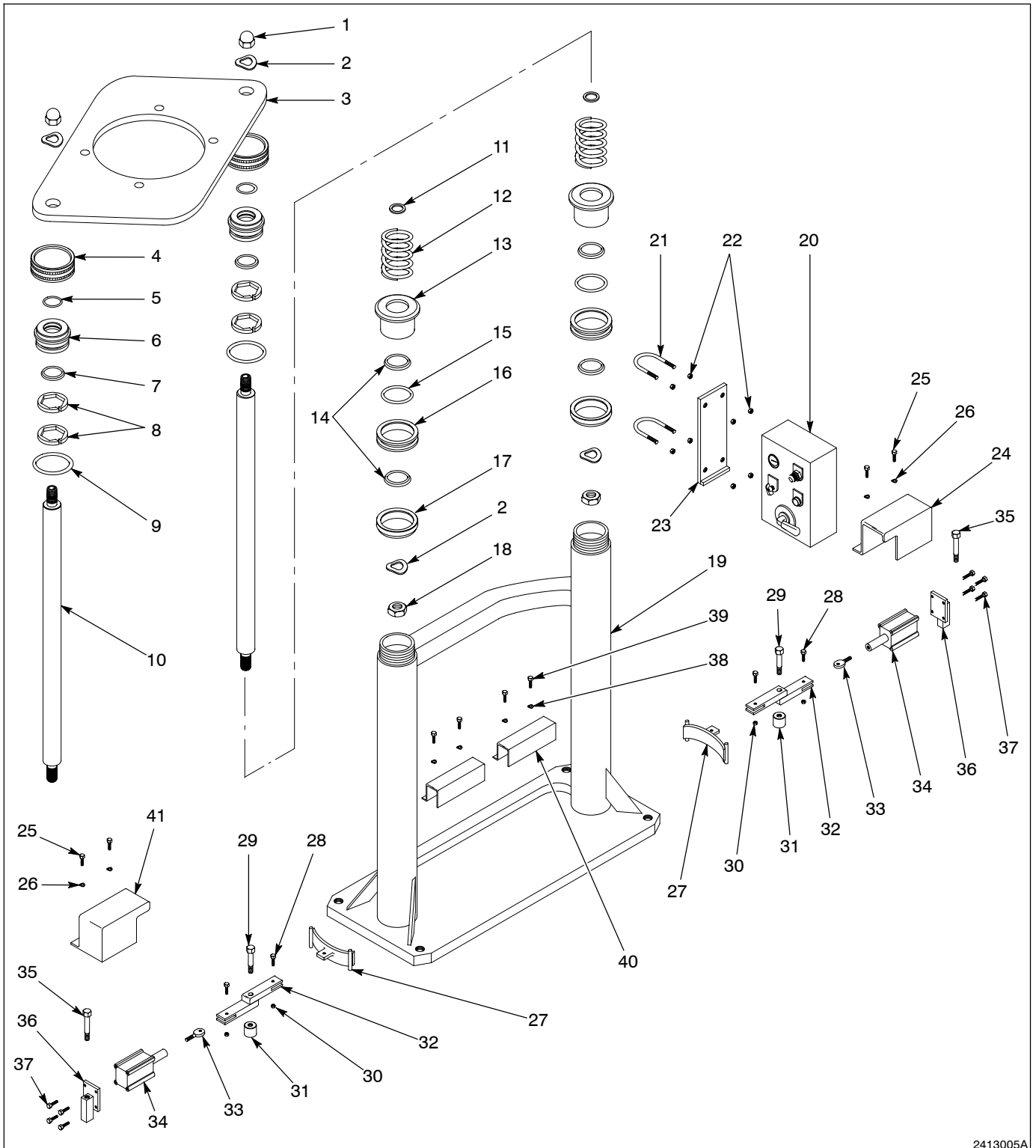

2413005A

Fig. 5 20-Liter Dual Post Ram

**20-Liter Dual Post Ram Kit**

See Figure 5.

Item	Part	Description	Quantity	Note
—	320 919	Kit, repair, 20-liter dual post	1	
7	Q-580 107	• U-packing	2	
8	Q-580 108	• Ring, wear	4	
9	Q-580 109	• O-ring	2	
11	Q-580 111	• Washer	2	
14	Q-580 114	• U-packing	2	
15	Q-580 115	• O-ring	2	
16	Q-580 116	• Bushing, piston	2	

**Hold Down**

See Figure 5.

Item	Part	Description	Quantity	Note
—	Q-999 999	Assembly, pail, hold down	1	
21	Q-580 121	• U-bolt	2	
22	Q-580 122	• Nut	8	
23	Q-580 123	• Plate, control box	1	
24	Q-580 124	• Cover, cylinder	1	
25	Q-580 125	• Bolt	4	
26	Q-580 126	• Washer, spring	4	
27	Q-580 127	• Clamp	2	
28	Q-580 128	• Bolt	4	
29	Q-580 129	• Pin	2	
30	Q-580 130	• Nut	4	
31	Q-580 131	• Collar	2	
32	Q-580 132	• Guide, clamp	2	
33	Q-580 133	• Connect	2	
34	Q-580 134	• Cylinder, air	1	
35	Q-580 135	• Pin	2	
36	Q-580 136	• Guide, cylinder	2	
37	Q-580 137	• Bolt	8	

*Continued on next page*

Item	Part	Description	Quantity	Note
38	Q-580 138	• Cover, hose	2	
39	Q-580 139	• Bolt	2	
40	Q-580 140	• Hose	1	
41	Q-580 141	• Cover, cylinder	1	

**Control Box**

See Figure 5.

Item	Part	Description	Quantity	Note
20	Q-580 120	Assembly, control box	1	
21	Q-580 121	• U-bolt	2	
22	Q-580 122	• Nut	8	
23	Q-580 123	• Plate, control box	1	
24	Q-580 124	• Cover, cylinder	1	
25	Q-580 125	• Bolt	4	
26	Q-580 126	• Washer, spring	4	
27	Q-580 127	• Clamp	2	
28	Q-580 128	• Bolt	4	
29	Q-580 129	• Pin	2	
30	Q-580 130	• Nut	4	
31	Q-580 131	• Collar	2	
32	Q-580 132	• Guide, clamp	2	
33	Q-580 133	• Connect	2	
34	Q-580 134	• Air cylinder	1	
35	Q-580 135	• Pin	2	
36	Q-580 136	• Guide, cylinder	2	
37	Q-580 137	• Bolt	8	
38	Q-580 138	• Washer, spring	2	
39	Q-580 139	• Bolt	2	
40	Q-580 140	• Cover, hose	1	
41	Q-580 141	• Cover, cylinder	1	

**Control Panel**

<b>Item</b>	<b>Part</b>	<b>Description</b>	<b>Quantity</b>	<b>Note</b>
—	Q-119 101	<ul style="list-style-type: none"><li>• Valve, hand</li></ul>	1	
—	Q-119 102	<ul style="list-style-type: none"><li>• Gauge, pressure</li></ul>	1	
—	Q-119 103	<ul style="list-style-type: none"><li>• Valve, clamp</li></ul>	1	
—	Q-119 104	<ul style="list-style-type: none"><li>• Regulator</li></ul>	1	
—	Q-119 105	<ul style="list-style-type: none"><li>• Valve, air inlet</li></ul>	1	

**20-Liter Single Post Ram**

See Figure 6.

Item	Part	Description	Quantity	Note
—	-----	Assembly, single post ram	1	
1	Q-240 101	• Cap, nut	1	
2	Q-240 102	• Spring, washer	2	
3	Q-240 103	• Pump, base	1	
4	Q-240 104	• Cap nut	1	
5	Q-240 105	• Seal	1	
6	Q-240 106	• Cover	1	
7	Q-240 107	• U-packing	1	
8	Q-240 108	• Wear ring	2	
9	Q-240 109	• O-ring	1	
10	Q-240 110	• Piston, rod	1	
11	Q-240 111	• Washer	1	
12	Q-240 112	• Spring	1	
13	Q-240 113	• Piston	1	
14	Q-240 114	• U-packing	2	
15	Q-240 115	• O-ring	1	
16	Q-240 116	• Piston, bushing	1	
17	Q-240 117	• Piston, cap	1	
18	Q-240 118	• Nut	1	
19	Q-240 119	• Nipple	4	
20	Q-240 120	• Air valve	1	
21	Q-240 121	• Adapter, 90-degree	3	
22	Q-240 122	• Hose and coupling	1	
23	Q-240 123	• Tee	1	
24	Q-240 124	• Regulator	1	
25	Q-240 125	• Union	1	
26	Q-240 126	• Hex bolt	4	
27	Q-240 127	• Valve, hand	1	
28	Q-240 128	• Silencer	1	
29	Q-240 129	• Ram	1	
30	Q-240 130	• Hose and coupling	1	

*Continued on next page*

**20-Liter Single Post Ram***(contd)*

Item	Part	Description	Quantity	Note
31	Q-240 131	• Hose	1	
32	Q-240 132	• One touch	2	
33	Q-240 133	• Set screw	4	
34	Q-240 134	• Handle	1	

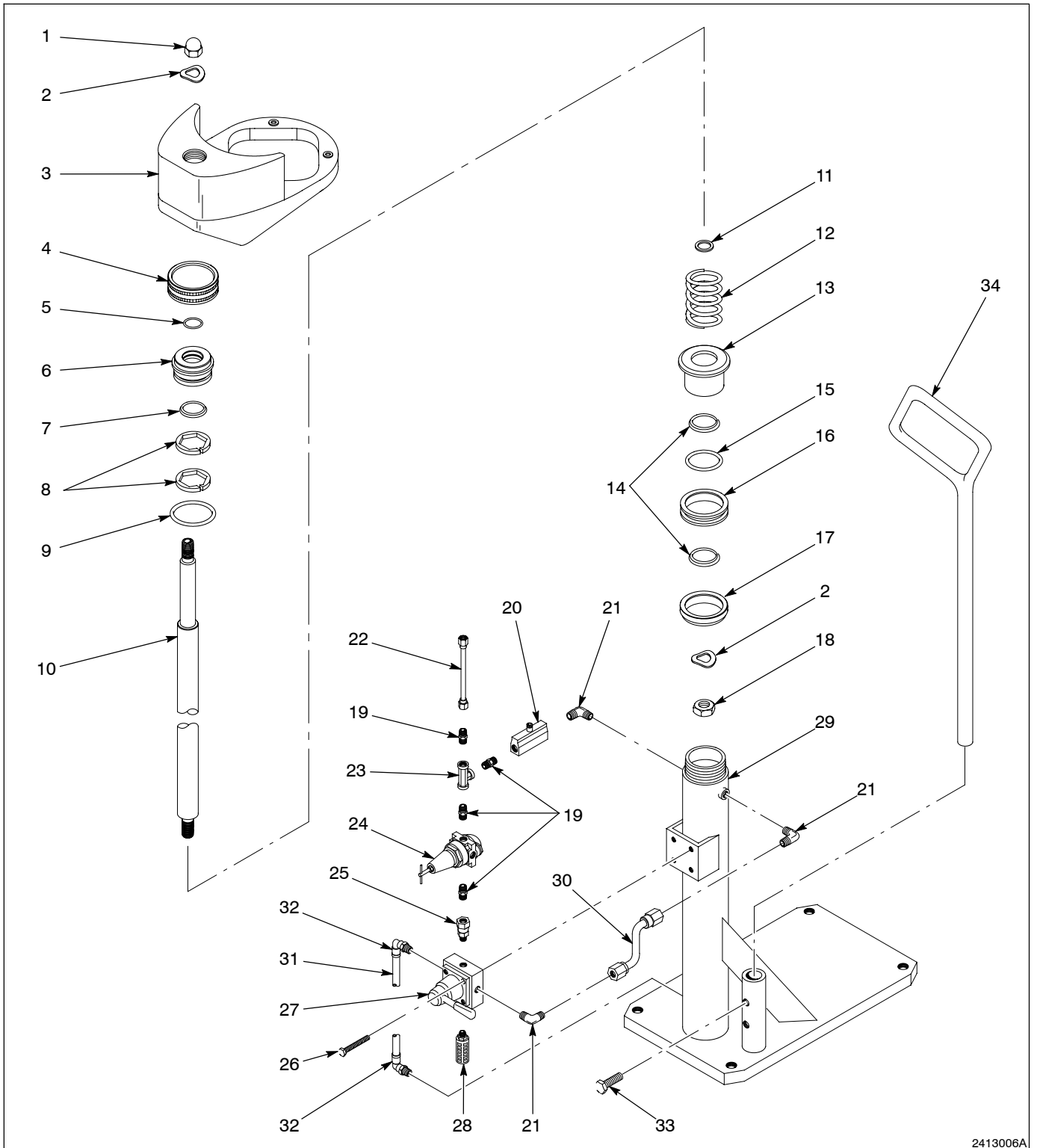

Fig. 6 20-Liter Single Post Ram

2413006A

**20-Liter Single Post Repair Kit**

See Figure 6.

<b>Item</b>	<b>Part</b>	<b>Description</b>	<b>Quantity</b>	<b>Note</b>
—	335 695	Kit, repair, 20-liter, single post	1	
7	Q-240 107	• U-packing	1	
8	Q-240 108	• Ring, wear	2	
9	Q-240 109	• O-ring	1	
11	Q-240 111	• Washer	1	
14	Q-240 114	• U-packing	2	
15	Q-240 115	• O-ring	1	
16	Q-240 116	• Piston, bushing	1	

## 9. Specifications

This section provides general specifications regarding pneumatics, hydraulics, and ram specifications.

**NOTE:** Because of possible technological or quality improvements, equipment specifications are subject to change without notice.

### Air

Pressure Ratio	58:1
Operating Air Pressure	3–6 bar (43–87 psi)
Max. Discharge Pressure	345 bar (5000 psi)
Air Inlet	$\frac{3}{4}$ in.
Max. Incoming Air Pressure	6 bar (87 psi)
Air Valves	Stainless steel plate, sliding acetal ring
Ram Air Inlet	$\frac{1}{4}$ npsm (female)
Max. Air Inlet Pressure	10 bar (150 psi)

### Pump

Pump Stroke	120 mm (4.7 in.)
Max. Delivery	16 l/min (4.2 gal/min)
Max. Pump Speed	80 cycles/min
Material Outlet	1 in.
Flow Volume	200 cc/cycle

### Dimensions and Weights

Air Motor	540 mm (21.25 in.) height 305 mm (12 in.) diameter
Ram	<b>raised:</b> 2576 x 1067 x 635 mm (101.4 x 42 x 25 in.) <b>lowered:</b> 1575 x 1067 x 635 (62 x 42 x 25 in.)
Piston Diameter	260 mm (10.2 in.)
Air Motor Stroke Length	121 mm (4.75 in.)
Pump Unit Weight	330 kg (727.5 lb)
Air Motor Weight	34 kg (75 lb)
Mounting Holes	4 x 14.2 mm (0.56 in.)

---

## **10. Options**

---

This section describes options available for the 58:1 QS pump system.

### **Electric Automatic Changeover**

The electric automatic changeover system allows the user to change material containers without shutting down the line. The changeover, control box, and stand mount between two existing pump systems.

#### **Low-Level Indicator**

When the active material container reaches the limit switch of the low-level indicator, the system automatically changes over to the standby pump. The low-level indicator utilizes a beacon and buzzer to signal that the automatic change over has taken place.

Refer to your automatic electric changeover system manual for more information.

### **Hold Down**

See Figure 5.

The pneumatic clamping hold down secures a 20-liter pail securely in place during the pumping process. The hold down includes two air cylinders (34), clamp guides (32), and a pair of clamps (27).

1. Before activating the hold down, properly position the 20-liter pail under the pail disk.
2. Activate the hold down lever located on the control box assembly (20) to energize the air cylinders (34) and engage the clamps (27).

The air cylinders extend and engage the hold down clamps around the base of the pail.

#### **Control Box**

See Figure 5.

The control box assembly (20) houses all pneumatic components for the hold down, as well as the UP/DOWN controls for the pail disk and blow-off hose pneumatics. On pumps without the hold down option, the standard pneumatic controls are mounted on the ram.