

# INSTRUCTIONS FOR THE MICROPROCESSOR BASED TEMPERATURE / PROCESS CONTROL



***Nordson***<sup>®</sup>

TEMPERATURE / PROCESS CONTROLLER

Specifications - Installation and Operating Instructions

**Nordson Corporation**  
Amherst, OH 44001

Manual 327040A

# CONTENTS

GETTING STARTED .....	3
MODEL IDENTIFICATION .....	3
INSTALLATION .....	4
WIRING .....	4
FRONT PANEL KEY FUNCTIONS .....	6
NOTATION CONVENTIONS FOR THE MENUS .....	8
THE HOME DISPLAY .....	8
OPERATION OF SELF TUNE FUNCTION .....	9
THEORY OF OPERATION .....	9
PROGRAM SETUP AND OPERATION .....	9
SERIAL COMMUNICATION OPTION .....	10
MENU SELECTIONS .....	10
PRIMARY MENU .....	10
SECONDARY MENU .....	11
SECURE MENU .....	16
ALARM TYPE AND ACTION .....	20
SPECIFICATIONS .....	23
DIAGNOSTIC ERROR MESSAGES .....	25, 26
INPUT RANGES .....	27
DIMENSIONS .....	28

## GETTING STARTED

1. Install the control as described on page 4.
2. Wire your control following the instructions on page 4. Serial Communications Option description and specific instructions start on page 10.
3. For best results when programming changes are necessary, make all the necessary changes in the Secure Menu (page 16) before making changes to the Secondary Menu (page 11). If error messages occur, check the Diagnostic Error Messages on page 25 for help.

Suppose for example you wish to change the input to type K and limit the set point range between 0° and 1000° C.

First, enter the Secure menu as instructed on page 5. Press the INDEX key until the display shows **Inp** and press the DOWN ARROW until the display shows **CA**. Don't forget to press the ENTER key to retain your setting.

Next, press the INDEX key to display **Unit**. Press the DOWN ARROW until the display shows **C**. Press ENTER.

Next, press the INDEX key until **SPL** is displayed (pass the **dPt** and **InPt** selections). Press the UP ARROW until the display shows **0**. Press ENTER.

Finally, press INDEX key to display **SPH**. Press the DOWN ARROW until the display shows **1000**. Press ENTER.

The necessary program changes are now complete. After 30 seconds the display will switch back to the temperature reading. If you want to return faster, press the UP ARROW and ENTER keys (at the same time) and then press the DOWN ARROW and INDEX keys ( again at the same time). This will 'back out' of the menu and immediately display the temperature reading.

If you want to use Self Tune, see the special section on page 9.

## MODEL IDENTIFICATION

PART NUMBER	OUTPUT A	OUTPUT B	SUPPLY VOLTAGE	OPTION
308434	15 VDC pulsed	Relay	100-240 VAC	
308433	15 VDC pulsed	Relay	100-240 VAC	RS-485
308650	15 VDC pulsed	Relay	100-240 VAC	
308649	15 VDC pulsed	Relay	100-240 VAC	RS-485

# INSTALLATION

Mount the instrument in a location that will not be subject to excessive temperature, shock, or vibration. All models are designed for mounting in an enclosed panel.

Select the position desired for the instrument on the panel. If more than one instrument is required, only two units can be mounted closely together, either one above the other or side by side. When mounted together, the mounting collar will require modification by removing the inside tab from each collar.

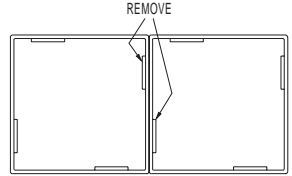

Prepare the panel by cutting and deburring the required opening.

From the front of the panel, slide the housing through the cut out. The housing gasket should be against the housing flange before installing.

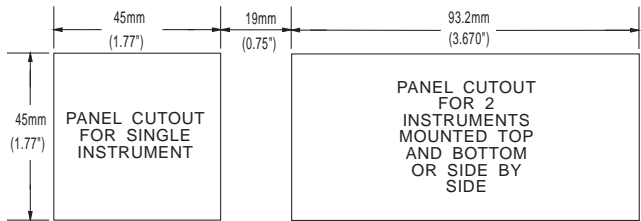

ALL TOLERANCES ARE  
-0.00 +0.25mm (-0.000 +0.010)

From the rear of the panel slide the mounting collar over the housing. Hold the housing with one hand and using the other hand, push the collar evenly against the panel until the spring loops are slightly compressed. The ratchets will hold the mounting collar and housing in place.

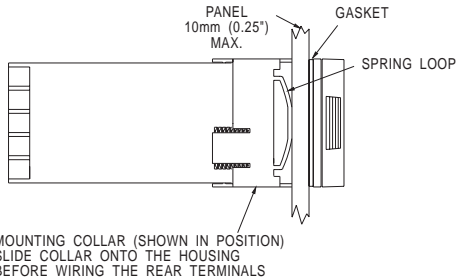

# WIRING

Do not run thermocouple or other class 2 wiring in the same conduit as power leads. Use only the type of thermocouple or RTD probe for which the control has been programmed. Maintain separation between wiring of sensor, auxiliary in or out, and other wiring. See the "Secure Menu" for input selection.

For thermocouple input always use extension leads of the same type designated for your thermocouple.

For supply connections use No. 16 AWG or larger wires rated for at least 75°C. Use copper conductors only. All line voltage output circuits must have a common disconnect and be connected to the same pole of the disconnect.

Input wiring for thermocouple, current, and RTD; and output wiring for current and 15 VDC is rated CLASS 2.

Control wiring is as shown.

### INPUTS

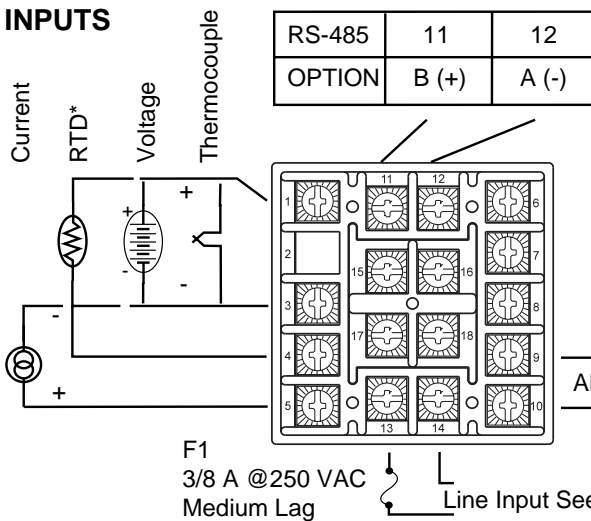

### ALARM OUTPUT

AL1 — Terminals 9 & 10 are Normally Open. See Rating Label.

F1 3/8 A @250 VAC Medium Lag  
 Line Input See Rating Label for details

\* For 2-wire 1000 Ω RTD use terminals 1 & 3. For 2-wire 100 Ω RTD use terminals 1 & 3, and place a jumper wire between terminals 3 & 4.

### OUTPUTS

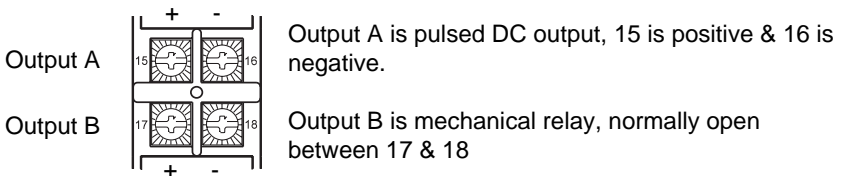

DO NOT RUN SIGNAL WIRING IN THE SAME CONDUIT OR CHASE AS THE POWER WIRING. ERRATIC OPERATION OR DAMAGE TO THE CONTROL CIRCUITRY WILL RESULT. UNUSED TERMINALS MUST NOT BE USED AS TIE POINTS FOR OTHER WIRING.

## FRONT PANEL KEY FUNCTIONS

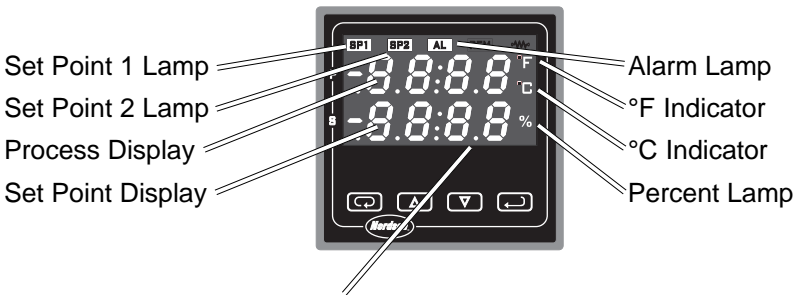

The decimal point flashes when Self Tune is operating.

Keys are illuminated when pressed. Key functions are as follows:



**INDEX:** Pressing the INDEX key advances the display to the next menu item. May also be used in conjunction with other keys as noted below.



**UP ARROW:** Increments a value, changes a menu item, or selects the item to ON. The maximum value obtainable is 9999 regardless of decimal point placement.



**DOWN ARROW:** Decrements a value, changes a menu item, or selects the item to OFF. The minimum value obtainable is -1999 regardless of decimal point placement.



**ENTER:** Pressing ENTER stores the value or the item changed. If not pressed, the previously stored value or item will be retained. The display will flash once when ENTER is pressed.

**UP ARROW & ENTER:** Pressing these keys simultaneously brings up the **secondary menu** starting at the alarm, tune, or cycle item (depending on programming). Pressing these keys for 5 seconds will bring up the **secure menu**.

**INDEX & DOWN ARROW:** Pressing these keys simultaneously will allow backing up one menu item, or if at the first menu item they will cause the display to return to the **primary menu**. If an alarm condition has occurred, these keys may be used to reset the alarm. To reset an alarm press and hold both keys for three seconds.

**INDEX & ENTER:** Pressing these keys simultaneously and holding them for 5 seconds allows recovery from the various error messages. The following menu items will be reset:

**ALiH:** Alarm inhibit

**OPEn InP:** Input error message

**bAd InP:** Input error message

**CHEC CAL:** Check calibration error

**Correct the problems associated with the above conditions before using these reset keys.** More than one error could be present. Caution is advised since several items are reset at one time.

While in the **Primary or Secondary Menu**, if no key is pressed for a period of 30 seconds, the display will return to the HOME position displaying the

temperature value. While in the **Secure Menu**, if no key is pressed for a period of 60 seconds, the display will return to the HOME position displaying the temperature value. Outputs are disabled (turned off) when the **Secure Menu** is active.

**NOTE:** To move to the **Primary Menu** quickly from any other menu, press the **UP ARROW & ENTER** keys followed by pressing the **INDEX & DOWN ARROW** keys.

### SECURITY LEVEL SELECTION

Four levels of security are provided. The display shows the current security level. To change security levels change the password value using the **UP & DOWN ARROW** keys and pressing the **ENTER** key. Refer to the password table (following) for the correct value to enter for the security level desired. The **SECr** menu item security level may be viewed or changed at any time regardless of the present security level.

To set the access level to, for example, **2**, at the **SECr** menu item press the **UP ARROW** key until the upper display show the password, **1101**. Press the **ENTER** key. The display will blink, and return with the level value, **2**, in the upper display.

The password values shown in the table cannot be altered, so retain a copy of these pages for future reference. This is the only reference made to password values in this instruction book.

### NOTATION CONVENTIONS FOR THE MENUS

Because of the number of features available in this control, information is included that may not apply to your specific control. All usable features are

#### PASSWORD TABLE

Security Level Menu	Status	Displayed Value When Viewed	Password Value To Enter
Primary Secondary Secure	Locked Locked Locked	1	1110
Primary Secondary Secure	Unlocked Locked Locked	2	1101
Primary Secondary Secure	Unlocked Unlocked Locked	3	1011
Primary Secondary Secure	Unlocked Unlocked Unlocked	4	111

included in this book, but may not be used in your process. To increase clarity the following conventions are used:

1. Certain features, Menu Items, and functions shown in this book may or may not appear on your control, depending on other Menu Item selections. At various places in the Menus there are notes identifying Menu Items that "control" or "direct" other menu items. If you are looking for a particular menu item and can't find it, check the menu item that is its "control" for proper setting.
2. The "#" symbol is used inside a group of characters to indicate which set point function (SP1 or SP2) is being affected.
3. *Features that apply only to the Serial Communications Option will be printed in Italics.*

## THE HOME DISPLAY

The home display is the normal display while the control is operating. If no errors or functions are active, the HOME display will indicate the Process Variable (the temperature, pressure, flow, RH, etc., that is being measured) on the top display and the Set Variable (Set Point 1) on the bottom.

Items that can change the HOME display are the Prog function, the **PctO** function, and any error message. Description of these special displays follow.

If **PctO** (Secondary Menu) is turned **On**, the lower display changes to show the active percentage of output as required to maintain SP1. The display is similar to the Auto/Manual display above, except that the letter indicators do not flash, and the output is displayed in whole percentages of output, not in tenths of a percent. If the control has both SP1 and SP2, the lower display will alternate between the SP1 percent output and the SP2 percent output.

Error messages are listed on Page 25.

## OPERATION OF SELF TUNE® FUNCTION

Self Tune allows automatic selection of the necessary parameters to achieve best control operation from your control. If you are using the control output as a simple on-off function (**Out1** set for **OnOF**), none of the following will apply.

## Theory of Operation

The Self Tune function calculates the **Pb1**, **rES**, and **rtE** parameters under the **PID tuneE** selection, and the **Fbnd** and **FrteE** parameters, as shown in the Secondary Menu . These values are determined by measuring the response of the process connected to the control. When Self Tune is started, the control temporarily acts as an on-off control. While in this mode the control measures the overshoot and undershoot of the process, and the period of the process (the time from peak value to the next peak value). These measurements are collected over a period that lasts three periods of overshoot and undershoot. The data collected over this time is then compared and calculated into final PID and Fuzzy Logic values. The effect of Fuzzy Logic on the process is still controlled by the **Fint** (fuzzy intensity) setting. If **Fint** is **0**, the **Fbnd** and **FrteE** will be calculated, but will have no effect. The calculations for the PID values are the same as used in the standard Ziegler - Nichols equations that have been recognized as standard for decades.

The only modification to the application of the Ziegler - Nichols equations is controlled by the **dfAC** menu item. This menu item controls the amount of rate (derivative) that is applied. A **dfAC** setting of **3** (factory default) or less allows for less damping. A **dfAC** setting of **4** allows for critical damping as set forth in Ziegler - Nichols. A **dfAC** setting of **5** or more allows over damping of the process.

## Program Setup and Operation

In the secondary menu set **tuneE** to **SELF**. Skip **LErn** and check to make sure that **dfAC** is set to the desired value. Back up to **LErn** and set to **YES**. The control will begin the Self Tune function. While the Self Tune function is active, the right hand decimal point on the lower display will blink. When Self Tune is complete, the blinking will stop.

After Self Tune is complete, the **tuneE** setting automatically switches to **PID**. This allows examination and / or modification of the values calculated. We recommend that you do not change the calculated values unless you have a firm understanding of the parameters involved and their function. For more information on PID tuning, please contact your supplier.

## Serial Communication Option.

The serial communications options allow the control to be written to and read from a remote computer or other similar digital device. Communication is allowed through a half duplex RS-485 port.

Wire the communication lines with shielded twisted wire as shown on Page 5. Wiring for the RS-485 is run from control to control in a daisy chain fashion with a termination resistor across the transmit and receive terminals of the last control in the chain. The recommended termination resistor value is 120 ohms. Consult your PLC instructions for the required resistor termination value for your system.

Select the control address and communication baud rate with the **Addr** and **bAUd** menu items in the Secure Menu. THE BAUD RATE AND ADDRESS MENU ITEMS WILL TAKE EFFECT ON THE NEXT POWER UP OF THE CONTROL. BE SURE TO POWER CYCLE THE CONTROL BEFORE USING THE NEW BAUD RATE AND ADDRESS.

In operation, you have the option of preventing a write command from the host computer. To prevent the host from writing to the control change the **LOrE** menu item in the Secondary Menu to **LOC**. To allow the host to write commands to the control set **LOrE** to **rE**. (The host does have the ability to change the **LOrE** state, but it is not automatic.)

If your system depends on constant reading or writing to and from the host, you may wish to set the No Activity Timer (**nAt**) to monitor the addressing of the control. When the **LOrE** is set to **rE** and the **nAt** is set to any value other than Off, the control will expect to be addressed on a regular basis. If the control is not addressed in the time set by the value of **nAt**, then the control will display the error message **CHEC LOrE**. To clear the message set **LOrE** to **LOC**.

## MENU SELECTIONS

### PRIMARY MENU

Press **INDEX** to advance to the next menu item. Press **UP ARROW** or **DOWN ARROW** to change the value in the display. Press **ENTER** to retain the value.

**SP1** Set Point 1 Adjust, Control Point 1.

**SP2** Set Point 2 Adjust, Control Point 2.

## SECONDARY MENU

Hold **UP ARROW & ENTER**. Press **INDEX** to advance to the next menu item. Press **UP ARROW** or **DOWN ARROW** to change the value in the display. Press **ENTER** to retain the value.

**A1Lo** Alarm 1 Low: The Low Alarm point is usually set below the Set Point. May not appear depending on **AL1** setting in **Secure Menu**.

**A1Hi** Alarm High: The High Alarm Point is usually set above the Set Point. May not appear depending on **AL1** setting in **Secure Menu**.

**Out1** Output selection: Select **OnOf**, **1tP**, **1PuL**, or **ProP**.

**ONOF** A setting of **ONOF** allows the control to operate as a simple on/off mode. This setting forces the control to turn off at set point, and on at the set point plus the differential (**SP\_d**). When selected, the **Out1/OnOF** menu item is followed by **####/SP1d**, and the **tunE**, **Pb**, **rES**, **OFS**, **rtE**, and **ArUP** selections in the Secondary menu and the **S1OL** and **S1OH** selections in the Secure menu are suppressed.

**SP\_d** Set Point On-Off Differential (hysteresis). Select **1** to **9999** (direct acting), or **-1** to **-9999** (reverse acting). This value will be negative for reverse acting set points, and positive for direct acting outputs. Set the value for the amount of difference between the turn off point (set point) and the turn on point. The following drawing shows output behavior for reverse and direct action.

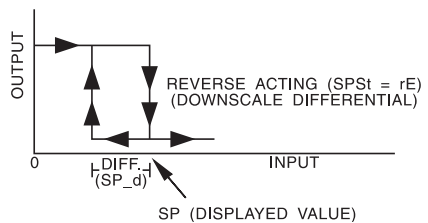
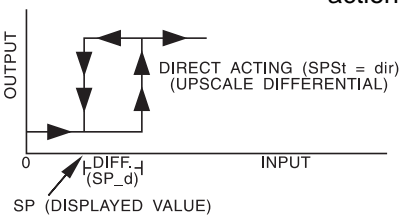

**##tP**

Time Proportioning Cycle Time. Select **1tP** to **80tP**.

**1tP** A setting of **1tP** is recommended for solid state outputs (SSR or 15VDC).

**2tP to 80tP** Time Proportioning Control is adjustable in 1 second steps. Recommended for mechanical outputs (relays, solenoids, etc.). For best contact life, a time should be selected as long as possible without causing the process to wander.

**#PuL** Pulsed Time Proportioning Output: Select **1PuL** to **7PuL**. **1PuL** = Linear and **7PuL** = most nonlinear. Changes output linearity for use in cooling applications or for an extremely fast response processes. At the center of the proportional band, a pulse value of 1 provides an output of one second on and one second off (50% output). A pulse value of 2 provides an output of one second on and two seconds off (33% output). Output at center of band equals one second on,  $2^{(\text{pulse value}-1)}$  seconds off.

**ProP** For Current (Code 5) outputs only.

The following menu items apply only if your control is equipped with a second set point (last digit of model number is not zero). If your control does not have a second set point, jump to the "tunE" menu on the next page.

**Out2** Output selection: Select **OnOf**, **2tP**, **2PuL**, or **ProP**.

**ONOF** A setting of **ONOF** allows the control to operate as a simple on/off mode. This setting forces the control to turn off at set point, and on at the set point plus the differential (**SP2d**). When selected, the **Out2/OnOf** menu item is followed by **####/SP2d**, and the **Pb2** selection in the Secondary menu and the **S2OL** and **S2OH** selections in the Secure menu are suppressed.

**SP2d** Set Point On-Off Differential (hysteresis). Select **1** to **9999** (direct acting), or **-1** to **-9999** (reverse acting). This value will be negative for reverse acting set points, and positive for direct acting outputs. Set the value for the amount of difference between the turn off point (set point) and the turn on point. The drawing on the previous page (See **SP1d**) shows output behavior for reverse and direct action.

**##tP** Time Proportioning Cycle Time. Select **1tP** to **80tP**.

**1tP** A setting of **1tP** is recommended for solid state outputs (SSR or 15VDC).

**2tP to 80tP** Time Proportioning Control is adjustable in 1 second steps. Recommended for mechanical outputs (relays, solenoids, etc.). For best contact life, a time should be selected as long as possible without causing the process to wander.

**#PuL** Pulsed Time Proportioning Output: Select **1PuL**

to **7PuL**. **1PuL** = Linear and **7PuL** = most nonlinear. Changes output linearity for use in cooling applications or for an extremely fast response processes. At the center of the proportional band, a pulse value of 1 provides an output of one second on and one second off (50% output). A pulse value of 2 provides an output of one second on and two seconds off (33% output). Output at center of band equals one second on,  $2^{(\text{pulse value}-1)}$  seconds off.

- tunE** Tuning Choice: Select **SELF**, **Pid**, **SLO**, **nor**, or **FAST**.
- SELF** The Controller will evaluate the Process and select the PID values to maintain good control. Active for SP1 only.
- LErn** Select **YES** or **no**
- YES** Start Learning the Process. After the process has been learned the menu item will revert to **no**.
- no** Learning will stay in present mode.
- dFAC** Damping factor, Select **OFF**, **1** to **7**. Sets the ratio of Rate to Reset for the SELF tunE mode. **7** = most Rate. Factory set to **3**. For a fast response process the value should be lowered (less Rate). For a slower process the value should be increased (more Rate).
- Pid** Manually adjust the PID values. PID control consists of three basic parameters, Proportional Band (Gain), Reset Time (Integral), and Rate Time (Derivative).
- Pb1** Proportional Band (Bandwidth). Select **1** to **9999** °F, °C, or counts.
- Pb2** Proportional Band (Bandwidth). Select **1** to **9999** °F, °C, or counts. Appears only if control is equipped with second set point and **Out2** is NOT selected as **ONOF**.
- rES** Automatic Reset Time. Select **OFF**, **0.1** to **99.9** minutes. Select **OFF** to switch to **OFS**.
- OFS** Manual Offset Correction Select **OFF**, **0.1** to **99.9%**. Select **OFF** to switch to **rES**.
- rtE** Rate Time. Select **OFF**, **0.01** to **99.99** minutes, Derivative.
- SLO** PID values are preset for a slow response process.
- nor** PID values are preset for a normal response process.
- FAST** PID values are preset for a fast response process.

**Pid2** Linkage of PID parameters between SP1 and SP2: Select **On** or **OFF**.

- On** Applies SP1 **rEs**, **rtE**, **Fbnd**, and **FrtE** terms to SP2 for heat/cool applications.
- OFF** SP2 functions without **rEs**, **rtE**, **Fbnd** and **FrtE**.

**ArUP** Anti- Reset Windup Feature: Select **On** or **OFF**.

- On** When ArUP is **On** the accumulated Reset Offset value will be cleared to 0% when the process input is not within the Proportional Band.
- OFF** When ArUP is **OFF**, the accumulated Reset Offset Value is retained in memory when the process input is not within the Proportional Band.

**ArtE** Approach Rate Time: Select **OFF**, **0.01** to **99.99** minutes. The function defines the amount of Rate applied when the input is outside of the Proportional Band. The ArtE time and the rtE time are independent and have no effect on each other. To increase damping effect and reduce overshoot set the approach rate time for a value greater than the natural rise time of the process (natural rise time = process value time to set point).

**Fint** Fuzzy Logic Intensity: Select **0** to **100%**. 0% is OFF (disables Fuzzy Logic). The function defines the amount of impact Fuzzy Logic will have on the output.

**Fbnd** Fuzzy Logic Error Band: Select **0** to **4000** °F, °C, or counts. Sets the bandwidth of the Fuzzy Logic. Set **Fbnd** equal to PID proportional band (**Pb1**) for best results.

**FrtE** Fuzzy Logic Rate of Change: Select **0.00** to **99.99** counts/second. For best initial setting, find the count/second change of process value near set point 1 with output ON 100%. Multiply this value by 3. Set **FrtE** to this calculated value.

**PEA** The Peak feature stores the highest input the control has measured since the last reset or Power On. At Power On PEA is reset to the present input. To manually reset the value **PEA** must be in the lower display. Press the **ENTER** key to reset. **PEA** will be reset and display the present input value.

**UAL** The Valley feature stores the lowest input the Instrument has measured since the last reset or Power On. At Power On **UAL** is reset to the present input. To manually reset the value **UAL** must be in the lower display. Press the **ENTER** key. **UAL** will be reset and display the present input value.

- PctO** Percent Output Feature: Select **On** or **OFF**.
- On** When selected **On**, the HOME lower display will indicate the output of the controller in percent. An "0" will appear in the right hand side of the lower display to indicate percent output for SP1. An "0" will appear on the right hand corner of the lower display to represent percent output for SP2, if the control is so equipped. The display will alternate between these values.
- OFF** Percent Output display is disabled.
- InPC** Input Correction: Select **±500** °F, °C, or counts. This feature allows the input value to be changed to agree with an external reference or to compensate for sensor error. **Note:** InPC is reset to zero when the input type is changed, or when decimal position is changed.
- FiLt** Digital Filter: Select **OFF**, **1** to **99**. In some cases the time constant of the sensor, or noise could cause the display to jump enough to be unreadable. A setting of 2 is usually sufficient to provide enough filtering for most cases, (2 represents approximately a 1 second time constant). When the 0.1 degree resolution is selected this should be increased to 4. If this value is set too high, controllability will suffer.
- LPbr** Loop Break Protection: Select **OFF**, **1** to **9999** seconds. If, during operation, the output is minimum (0%) or maximum (100%), and the input moves less than 5°F (3°C) or 5 counts over the time set for LPbr, the **LOOP bAd** message will appear. This condition can also be routed to an Alarm Condition if alarms are present and turned On (see ALbr in the secure menu). The loop break error can be reset by pressing the **ENTER** key when at the LPbr menu item. The **INDEX** & **ENTER** keys may also be used.
- LORe** *(Option RS-485, Serial Communications) Local / Remote Status: Select **LOC** or **rE**.*
- LOC** *The host computer is advised not to send remote commands. Any write commands sent to the controls will be rejected.*
- rE** *The host computer is allowed to send write commands. If the control is not addressed within the time set in the **nAt** (No Activity Timer, see Secure Menu) the **CHEC LorE** error message will be displayed.*
- Addr** *(Option RS-485, Serial Communications) Control Address: Set from 1 to 3FF. This number (hexadecimal, base 16) must match the*

address number used by the host computer. Viewed only in this menu. To change this parameter, see **Addr** in the Secure Menu.

## **SECURE MENU**

Hold **UP ARROW** & **ENTER** for 5 Seconds. Press **INDEX** to advance to the next menu item. Press **UP ARROW** or **DOWN ARROW** to change the value in the display. Press **ENTER** to retain the value.

**OUTPUTS ARE DISABLED (TURNED OFF) WHILE CONTROL IS IN SECURE MENU.**

**SECr** Security Code: See the Security Level Selection and the Password Table in this manual, in order to enter the correct password.

**InP** Input Type: Select one of the following. Refer to the Input wiring section for the proper wiring.

<b>J-IC</b>	Type "J" Thermocouple, Iron/Constantan (NIST)
<b>CA</b>	Type "K" Thermocouple Chromel/Alumel
<b>E-</b>	Type "E" Thermocouple Chromel/Constantan
<b>t-</b>	Type "T" Thermocouple Copper/Constantan
<b>L-</b>	Type "L" Thermocouple Iron/Constantan (DIN)
<b>n-</b>	Type "N" Thermocouple Nicrosil/Nisil
<b>r-13</b>	Type "R" Thermocouple Pt 13%Rh/Pt
<b>S-10</b>	Type "S" Thermocouple Pt 10%Rh/Pt
<b>b-</b>	Type "B" Thermocouple Pt 6%Rh/Pt 30%Rh
<b>C-</b>	Type "C" Thermocouple W 5%Re/W 26%Re
<b>P392</b>	100 ohm Platinum (NIST 0.00392 $\Omega/\Omega/^\circ\text{C}$ )
<b>n120</b>	120 ohm Nickel
<b>P385</b>	100 ohm Platinum (DIN 0.00385 $\Omega/\Omega/^\circ\text{C}$ )
<b>1P38</b>	1000 ohm Platinum (DIN 0.00385 $\Omega/\Omega/^\circ\text{C}$ )
<b>Curr</b>	DC Current Input 0.0 to 20.0 or 4.0 to 20.0 mA.
<b>UoLt</b>	DC Voltage Input 0.0 to 10.0 or 1.0 to 10.0 volts.
<b>diFF</b>	DC Voltage Input -10 to +10 mV.
<b>----</b>	Reserved

**OSUP** Zero Suppression: Select **On** or **OFF**. Only with Current and Voltage input types.

**OFF** The input range will start at 0 (zero) Input.

**On** The input range will start at 4.00 mA or 1.00 V.

**Unit** **F, C** or **None**.

**F**  $^\circ\text{F}$  descriptor is On and temperature inputs will be displayed in actual degrees Fahrenheit.

**C**  $^\circ\text{C}$  descriptor is On and temperature inputs will be displayed in actual degrees Celsius.

**nonE**  $^\circ\text{F}$  and  $^\circ\text{C}$  descriptors will be Off. This is only available with Current and Voltage Inputs.

**dPt** Decimal Point Positioning: Select **0**, **0.0**, **0.00**, **0.000**, or **.0000**. On temperature type inputs this will only effect the Process Value, SP1, SP2, ALLo, ALHi, and InPC. For Current and Voltage Inputs all Menu Items related to the Input will be affected.

**0** No decimal Point is selected. This is available for all Input Types.

**0.0** One decimal place is available for Type J, K, E, T, L, RTD's, Current and Voltage Inputs.

**0.00** Two decimal places is only available for Current and Voltage Inputs.

**0.000** Three decimal places is only available for Current and Voltage inputs.

**.0000** Four decimal places is only available for Current and Voltage inputs.

**InPt** Input Fault Timer: Select **OFF**, **0.1** to **540.0** minutes. Whenever an Input is out of range (UFL or OFL displayed), shorted, or open the timer will start. When the time has elapsed, the controller will revert to the output condition selected by **InPb** below. If OFF is selected, the Input Fault Timer will not be recognized (time = infinite).

**InPb** Input Fail Action: Select **FAIL**, **AVE**, or **PrE**. When the Input is out of range (UFL or OFL displayed) and the Input timer (**InPt**) time has elapsed, the controller will revert to the selected condition.

**FAIL** Outputs are disabled (go to 0% output).

**AVE** The outputs will hold at the last known average percentage of output.

**PrE** The outputs will maintain a preprogrammed percentage of output as specified in **PrE1** and **PrE2**.

**PrE1** Preset output for Set Point 1. Select 0 to 100%.

**PrE2** Preset output for Set Point 2. Select 0 to 100%.

**SEnC** Sensor Rate of Change: Select **OFF**, **1** to **4000** °F, °C, or counts per 1 second period. This value is usually set to be slightly greater than the fastest process response expected during a 1 second period, but measured for at least 2 seconds. If the process is faster than this setting, the SEnC bAd error message will appear. The outputs will then be turned off. This function can be used to detect a runaway condition, or speed up detection of an open thermocouple. Use the INDEX & ENTER keys to reset.

**SCAL** Scale Low: Select **100** to **9999** counts below **SCAH**. The total span between **SCAL** and **SCAH** must be within 11998 counts. Maximum setting range is -1999 to +9999 counts. For Current and Voltage

inputs, this will set the low range end. Viewable only for Thermocouple and RTD ranges.

**SCAH** Scale High: Select **100** to **9999** counts above **SCAL**. The total span between **SCAL** and **SCAH** must be within 11998 counts. Maximum setting range is -1999 to +9999 counts. For Current and Voltage inputs, this will set the high range end. Viewable only for Thermocouple and RTD ranges.

**SPL** Set Point Low: Select from the lowest input range value to **SPH** value. This will set the minimum SP1 or SP2 value that can be entered. The value for SP1 or SP2 will not stop moving when this value is reached.

**SPH** Set Point High: Select from the highest input range value to **SPL** value. This will set the maximum SP1 or SP2 value that can be entered. The value for SP1 or SP2 will not stop moving when this value is reached.

**SP1O** Set Point 1 Output Select: Select **OutA** or **Outb**.

**OutA** Set Point 1 is routed through Output A, Set Point 2 (if equipped) is routed through Output B.

**Outb** Set Point 1 is routed through Output B, Set Point 2 (if equipped) is routed through Output A.

**S1St** Set Point 1 State: Select **dir** or **rE**.

**dir** Direct Action. As the input increases the output will increase. Most commonly used in cooling processes.

**rE** Reverse Action. As the input increases the output will decrease. Most commonly used in heating processes.

If **Out1** is set for **##tP**, **#PUL**, or **ProP**, then **S1OL** and **S1OH** (following) appear. If **Out1** is set for **ONOF**, then skip to **S1rE**.

**S1OL** Set Point Output Low Limit: Select **0** to **100%** but not greater than **S1OH**. This item limits the lowest output value. This is useful for adding a bias to the process when needed. Factory set to **0** for output codes 1,2, and 3. Factory set to **20** for output code 5 (20% output equals 4 mA output).

**S1OH** Set Point 1 Output High Limit: Select **0** to **100%** but not less than **S1OL** for output codes 1, 2, or 3. Select **0** to **102%** but not less than **S1OL** for output code 5. This item allows setting the maximum output limit. This is useful with processes that are over powered. Adjustment to 102% allows setting current output to force a full on

condition for output devices which do not have bias adjustments.  
Factory set to **100** for all output codes.

If **Out1** is set for **##tP**, **#PUL**, or **ProP**, then skip to **S1LP** below.

**S1rE** Set Point 1 Reset. Select **OnOF** or **Hold**.  
**OnOF** Control will automatically reset when process passes back through **SP1d**.  
**HoLd** Manual Reset. Reset (acknowledge) by simultaneously pressing the **INDEX & DOWN ARROW** keys for 5 seconds.

**S1Pi** Set Point 1 Power Interrupt. Select **On** or **OFF**.  
**On** Alarm Power Interrupt is **On**. Control will automatically reset on power-up if no alarm condition exists.  
**OFF** Alarm Power Interrupt is **OFF**. Control will power-up in alarm condition regardless of condition of process.

**S1iH** Set Point 1 Inhibit: Select **On** or **OFF**.  
**On** Alarm Inhibit is **On**. Alarm action is suspended until the process value first enters a non-alarm condition.  
**OFF** Alarm Inhibit is **OFF**.

**S1LP** Set Point Lamp: Select **O on** or **OoFF**.  
**O on** Lamp ON when Output is ON.  
**OoFF** Lamp OFF when Output is ON.

If your control is not equipped with Set Point 2, then proceed to the alarm section (next page).

**S2t** Set Point 2 type: Select **Abs** or **dE**.  
**AbS** Absolute **SP2**. **SP2** is independent of **SP1**, and may be set anywhere between the limits of **SPL** and **SPH**.  
**dE** Deviation **SP2**. **SP2** is set as a deviation from **SP1**, and allows **SP2** to retain its relationship with **SP1** when **SP1** is changed (tracking **SP2**).

**S2St** Set Point 2 State: Select **dir** or **rE**.  
**dir** Direct Action. As the input increases the output will increase. Most commonly used in cooling processes.  
**rE** Reverse Action. As the input increases the output will decrease. Most commonly used in heating processes.

If **Out2** is set for **##tP**, **#PUL**, or **ProP**, then **S2OL** and **S2OH** (following) appear. If **Out2** is set for **ONOF**, then skip to **S2rE**.

**S2OL** Set Point Output Low Limit: Select **0** to **100%** but not greater than **S2OH**. This item limits the lowest output value. This is useful for adding a bias to the process when needed. Factory set to **0** for output codes 1,2, and 3. Factory set to **20** for output code 5 (20% output equals 4 mA output).

**S2OH** Set Point 1 Output High Limit: Select **0** to **100%** but not less than **S2OL** for output codes 1, 2, or 3. Select **0** to **102%** but not less than **S2OL** for output code 5. This item allows setting the maximum output limit. This is useful with processes that are over powered. Adjustment to 102% allows setting current output to force a full on condition for output devices which do not have bias adjustments. Factory set to **100** for all output codes.

**S2rE** Set Point 2 Reset. Select **OnOF** or **Hold**.  
**OnOF** Control will automatically reset when process passes back through **SP2d**.  
**HoLd** Manual Reset. Reset (acknowledge) by simultaneously pressing the **INDEX & DOWN ARROW** keys for 5 seconds.

**S2Pi** Set Point 2 Power Interrupt. Select **On** or **OFF**.  
**On** Alarm Power Interrupt is **On**. Control will automatically reset on power-up if no alarm condition exists.  
**OFF** Alarm Power Interrupt is **OFF**. Control will power-up in alarm condition regardless of condition of process.

**S2iH** Set Point 2 Inhibit: Select **On** or **OFF**.  
**On** Alarm Inhibit is **On**. Alarm action is suspended until the process value first enters a non-alarm condition.  
**OFF** Alarm Inhibit is **OFF**.

**S2LP** Set Point 2 Lamp: Select **O on** or **OoFF**.  
**O on** Lamp ON when Output is ON.  
**OoFF** Lamp OFF when Output is ON.

## ALARM TYPE AND ACTION



**Caution: In any critical application where failure could cause expensive product loss or endanger personal safety, a redundant limit controller is required.**

When setting an alarm value for an absolute alarm (**A#t = AbS**), simply set the value at which the alarm is to occur.

When setting the alarm value for a deviation alarm (**A#t = dE**), set the difference in value from the Set Point (SP) desired. For example if a low alarm is required to be 5 degrees below the SP, then set **A#Lo** to **-5**. If a high alarm is required 20 degrees above the SP, then set **A#Hi** to **+20**. If SP is changed, the alarm will continue to hold the same relationship as originally set.

The following diagram (below) shows the action and reset functions for both absolute and deviation alarms.

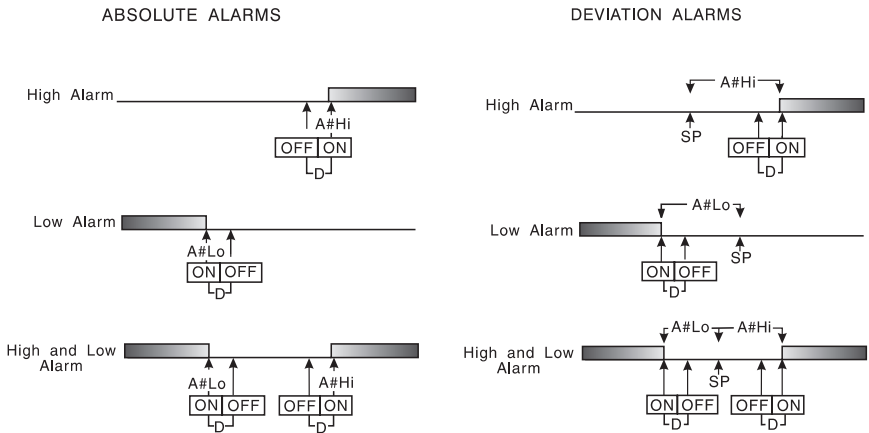

When Alarm Power Interrupt, **A#Pi**, is programmed **ON** and Alarm Reset, **A#rE**, is programmed for **Hold**, the alarm will automatically reset upon a power failure and subsequent restoration if no alarm condition is present.

If Alarm Inhibit, **A#iH**, is selected **ON**, an alarm condition is suspended upon power up until the process value passes through the alarm set point once. Alarm inhibit can be restored as if a power up took place by pressing both the **INDEX** and **ENTER** keys for 5 seconds.



**Warning: Resetting a high alarm inhibit will not cause an alarm to occur if the Process Value does not first drop below the high alarm setting. Do not use the Alarm Inhibit feature if a hazard is created by this action. Be sure to test all combinations of high and low alarm inhibit actions before placing control into operation.**

The following menu items apply only to the alarm.

- AL1** Alarm 1 function: Select **OFF**, **Lo**, **Hi**, or **HiLo**.
- OFF** Alarm 1 is disabled. No Alarm 1 menu items appear in the Secondary or Secure menus.

**Lo** Low Alarm Only. **A1Lo** appears in the Secondary Menu.  
**Hi** High Alarm Only. **A1Hi** appears in the Secondary Menu.  
**HiLo** High and Low Alarms. Both **A1Lo** and **A1Hi** appear in the Secondary Menu, and share the same Alarm 1 Relay output.

If **AL1** is set to **OFF** and the control is not equipped with options, the Secure Menu ends. If **AL1** is set to **OFF** and the control is equipped with options, proceed to **Addr** below.

**A1t** Alarm 1 Type: Select **AbS** or **dE**  
**AbS** Absolute Alarm that may be set anywhere within the values of **SCAL** and **SCAH** and is independent of **SP1**.  
**dE** Deviation Alarm that may be set as an offset from **SP1**. As **SP1** is changed the Alarm Point will track with **SP1**. A deviation alarm will also track any active ramp or soak set point.

**A1rE** Alarm 1 Reset: Select **OnOF** or **Hold**.  
**OnOF** Automatic Reset.  
**Hold** Manual Reset. Reset (acknowledge) by simultaneously pressing the **INDEX** & **DOWN ARROW** keys for 5 seconds.

**A1Pi** Alarm 1 Power Interrupt: Select **On** or **OFF**.  
**On** Alarm Power Interrupt is **On**.  
**OFF** Alarm Power Interrupt is **OFF**.

**A1iH** Alarm 1 Inhibit: Select **On** or **OFF**.  
**On** Alarm Inhibit is **On**. Alarm action is suspended until the process value first enters a non-alarm condition.  
**OFF** Alarm Inhibit is **OFF**.

**A1St** Alarm 1 Output State: Select **CLOS** or **OPEn**.  
**CLOS** Closes Contacts at Alarm Set Point.  
**OPEn** Opens Contacts at Alarm Set Point.

**A1LP** Alarm 1 Lamp: Select **O on** or **OoFF**.  
**O on** Alarm Lamp is ON when alarm contact is closed.  
**OoFF** Alarm Lamp is OFF when alarm contact is closed.

**A1Lb** Alarm 1 Loop Break. Select **On** or **OFF**.  
**On** Loop Break Condition will cause an Alarm Condition.  
**OFF** Loop Break will not affect the Alarm Condition.

- Addr** (Option RS-485, Serial Communications) Control Address: Set from **1** to **3FF**. This number (hexadecimal, base 16) must match the address number used by the host computer.
- bAUd** (Option RS-485, Serial Communications) Communication Baud Rate: Select **300, 1200, 2400, 4800, 9600, or 19200**. This number must match the baud rate used by the host computer.
- nAt** (Option RS-485, Serial Communications) No Activity Timer: Set from **OFF** or **1** to **99** minutes.
- 1 - 99** Maximum time between host computer accesses. If timer counts to 0, CHEC/LorE will be displayed.
- OFF** No Activity Timer function is disabled.

## SPECIFICATIONS

**Selectable Inputs:** Thermocouple, RTD, DC Voltage, or DC Current selectable.

**Input Impedance:**

Thermocouple = 3 megohms minimum.      RTD current = 200 uA.  
 Current = 10 ohms.                                      Voltage = 5000 ohms.

**Sensor Break Protection:** De-energizes control output to protect system after customer set time. (See **InPt** in Secondary Menu.)

**Set Point Range:** Selectable (See Range Chart Page 27).

**Display:** Two 4 digit, 7 segment 0.3" high LEDs.

**Control Action:** Reverse (usually heating), Direct (usually cooling) selectable.

**Proportional Band:** 1 to 9999 °F, °C, or counts.

**Reset Time (Integral):** Off or 0.1 to 99.9 minutes.

**Rate Time (Derivative):** Off or 0.01 to 99.99 minutes.

**Cycle Rate:** 1 to 80 seconds.

**On - Off Differential:** Adjustable 1° F, 1° C, or 1 count to full scale in 1° F, 1° C, or 1 count steps.

**Alarm On - Off Differential:** 1° F, 1° C, or 1 count.

**Fuzzy Percent:** 0 to 100%.

**Fuzzy Rate:** Off or 0.01 to 99.99 minutes.

**Fuzzy Band:** Off or 1 to 4000 °F, °C, or counts.

**Accuracy:** ±0.25% of span, ±1 least significant digit.

**Resolution:** 1 degree or 0.1 degree, selectable.

**Line Voltage Stability:**  $\pm 0.05\%$  over the supply voltage range.

**Temperature Stability:**  $4\mu\text{V}/^\circ\text{C}$  ( $2.3\mu\text{V}/^\circ\text{F}$ ) typical,  $8\mu\text{V}/^\circ\text{C}$  ( $4.5\mu\text{V}/^\circ\text{F}$ ) maximum ( $100\text{ ppm}/^\circ\text{C}$  typical,  $200\text{ ppm}/^\circ\text{C}$  maximum).

**Common Mode Rejection:** 140 db minimum at 60 Hz.

**Normal Mode Rejection:** 65 db typical, 60 db at 60 Hz.

**Isolation:**

- Relay and SSR outputs:** 1500 Vac to all other inputs and outputs.
- SP1 and SP2 Current outputs:** 500 Vac to all other inputs and outputs, but not isolated from each other,
- SP1 and SP2 Switched Voltage outputs:** 500 Vac to all other inputs and outputs, but not isolated from each other.
- Process Output (934, 936):** 500 VAC to all other inputs and outputs.

**Supply Voltage:** 100 to 240 Vac, nominal.,  $+10\text{ }-15\%$ , 50 to 400 Hz. single phase; 132 to 240 Vdc, nominal.,  $+10\text{ }-20\%$ .

**Supply Voltage (Option 9502):** 12 to 24 Vdc, Vac 40-400 Hz,  $\pm 20\%$ .

**Power Consumption:** 5VA maximum.

**Operating Temperature:**  $-10\text{ to }+55\text{ }^\circ\text{C}$  ( $+14\text{ to }131\text{ }^\circ\text{F}$ ).

**Storage Temperature:**  $-40\text{ to }+80\text{ }^\circ\text{C}$  ( $-40\text{ to }176\text{ }^\circ\text{F}$ ).

**Humidity Conditions:** 0 to 90% up to  $40\text{ }^\circ\text{C}$  non-condensing 10 to 50% at  $55\text{ }^\circ\text{C}$  non-condensing.

**Memory Backup:** Nonvolatile memory. No batteries required.

**Control Output Ratings:**

- SSR:** 2.0 A combined outputs A & B @ 240 Vac at  $25\text{ }^\circ\text{C}$  ( $77^\circ\text{F}$ ). Derates to 1.0 A @  $55\text{ }^\circ\text{C}$  ( $130^\circ\text{F}$ ).
- Relay:** SPST, 3 A @ 240 Vac resistive; 1.5A @240 Vac inductive; Pilot duty rating 240 VA, 2 A @ 120 Vac or 1 A 240 Vac.
- Alarm Relay:** SPST, 3 A @ 240 Vac resistive; 1/10 HP@ 120 Vac.
- Current (isolated):** 0 to 20 mA across 600 ohms maximum.
- Switched Voltage (isolated):** 15 Vdc @ 20 mA.

**Panel Cutout:** 45 mm x 45 mm (1.775" x 1.775").

**Depth Behind Mounting Surface:** 115.3 mm (4.54").

**Weight:** 220 g (8 oz).

**Agency Approvals:** UL E83725, CE.

**Front Panel Rating:** UL Type 4, (IP65).

## DIAGNOSTIC ERROR MESSAGES

DISPLAY	MEANING	SP OUTPUTS	ACTION REQUIRED
<b>UFL</b> or <b>OFL</b>	Underflow or Overflow: Process value has exceeded input range ends.	Set point outputs active Alarm active	Input signals may normally go above or below range ends. If not, check input and correct.
	<b>UFL</b> or <b>OFL</b> will sequence to display one of these messages if the <b>InPt</b> is set for a time value.	Set point outputs inactive Alarm active	To reset use the <b>INDEX &amp; ENTER</b> keys. When <b>InPt</b> (input fault timer) has been set for a time, the outputs will be turned off after the set time. Setting the time to OFF causes the outputs to remain active, however <b>UFL</b> or <b>OFL</b> will still be displayed.
<b>bAd InP</b>	For RTD inputs RTD is open or shorted.		Correct or replace sensor. To reset use the <b>INDEX &amp; ENTER</b> keys.
<b>OPEn InP</b>	For THERMOCOUPLE inputs thermocouple is open.		
<b>LOOP bAd</b>	The sensor may be defective, heater fuse open, heater open, or the final power output device is bad.	Set point outputs inactive. Alarm active.	Correct or replace sensor, or any element in the control loop that may have failed. Correct the problem, and reset the control by pressing the <b>INDEX</b> and <b>ENTER</b> keys, or index to LPbr and press <b>ENTER</b> .
<b>SEnC bAd</b>	Sensor Rate of Change exceeded the programmed limits set for <b>SEnC</b> .	Set point outputs inactive. Alarm Active	Check for the cause of the error. The value setting may be too slow for the process, or the sensor is intermittent. Correct the problem and press <b>INDEX</b> and <b>ENTER</b> to reset.
<b>CHEC CAL</b>	Check calibration appears as an alternating message if the instrument calibration nears tolerance edges.	Set point outputs active Alarm active	Remove the instrument for service and / or recalibration. To reset use the <b>INDEX &amp; ENTER</b> keys.
	Check calibration appears as a flashing message if the instrument calibration exceeds specification.	Set point outputs inactive Alarm active	Remove the instrument for service and / or recalibration. To reset use the <b>INDEX &amp; ENTER</b> keys.

## DIAGNOSTIC ERROR MESSAGES

DISPLAY	MEANING	SP OUTPUTS	ACTION REQUIRED
<b>No display lighted</b>	Display is blank. Instrument is not getting power, or the supply voltage is too low.	Set point outputs inactive Alarm inactive	Check that the power supply is on, or that the external fuses are good.
<b>FAIL tEst</b>	Fail test appears upon power up if the internal diagnostics detect a failure. This message may occur during operation if a failure is detected. Displays flash.	Set point outputs inactive Alarm inactive	The display alternate between FAIL tEst and one of the following messages: <b>FAcT dFLt</b> : Memory may be corrupted. Press the <b>ENTER</b> key and the <b>DOWN ARROW</b> key to start the factory default procedure. Recheck controller programming. <b>rEt FAcT</b> : Unrecoverable error, return to factory for service.
<b>CHEC SP1, CHEC SP2,</b>	This message will appear upon power up if SP1, or SP2 is set outside of the <b>SPL</b> or <b>SPH</b> values.	Set point outputs inactive Alarm active	Correct the <b>SP1, etc.</b> or adjust the <b>SPL</b> or <b>SPH</b> values by programming new values.
<b>CHEC SPL or CHEC SPH</b>	This message appears at power up if <b>SPL</b> or <b>SPH</b> values are programmed outside the input range ends.	Set point outputs active Alarm inactive	Correct the <b>SPL</b> or <b>SPH</b> values by programming new values.
<b>CHEC LorE</b>	This message appears if the Serial Communications has timed out.	Set point outputs active Alarm inactive	Restore the communications line and switch the LorE to LOC.
<b>ArEA</b>	This message appears if the ambient temperature of the control is out of range or RJC sensor is broken.	Set point outputs active Alarms active	Correct the ambient temperature conditions. Ventilate the area of the cabinet or check for clogged filters. If RJC broken, return to factory for service.

## Input Ranges (Field Selectable)

### Thermocouple Types

Input Type	Type J or L* Iron-Constantan	Type K* Chromel-Alumel	Type T* Copper-Constantan	Type E* Chromel-Constantan
Range 1°F 1°C	-100 to +1600 -73 to +871	-200 to +2500 -129 to +1371	-350 to +750 -212 to +398	-100 to +1800 -73 to +982
Input Type	Type R PT 13%-PT	Type S PT 10%-PT	Type B PT 6% RE-PT 30% RE	Type C W 5% RE-W26% RE
Range 1°F 1°C	0 to 3200 -17 to +1760	0 to 3200 -17 to +1760	+75 to 3308 +24 to 1820	0 to 4208 -17 to 2320
Input Type	Type N* Ni Chr Si-Ni Si	* These Input Types can be set for 0.1° display. If temperature goes above 999.9° or less than -199.9° the display will return to whole degree resolution.		
Range 1°F 1°C	-100 to +2372 -73 to +1300			

### RTD Types

Input Type	100 Ohm Platinum 0.00385 DIN Curve*	100 Ohm Platinum 0.00392 Nist Curve*	120 Ohm Nickel 0.00628 US Ind. Curve*	1000 Ohm Platinum 0.00385 Nist Curve*
Range 1°F 1°C	-328 to +1607 -200 to +875	-328 to +1607 -200 to +875	-112 to +608 -80 to +320	-328 to +1607 -200 to +875

### Process Input Types

The 0 to 20 mAdc, 4 to 20 mAdc, 0 to 10 Vdc, 2 to 10 Vdc, and -10 to +10 mVdc inputs are fully scalable from a minimum of 100 counts span placed anywhere within the within the range of -1999 to +9999. Decimal point position is adjustable from the zero place (9999), tenths (999.9), hundredths (99.99), thousandths (9.999), or ten thousandths (.9999).

# DIMENSIONS

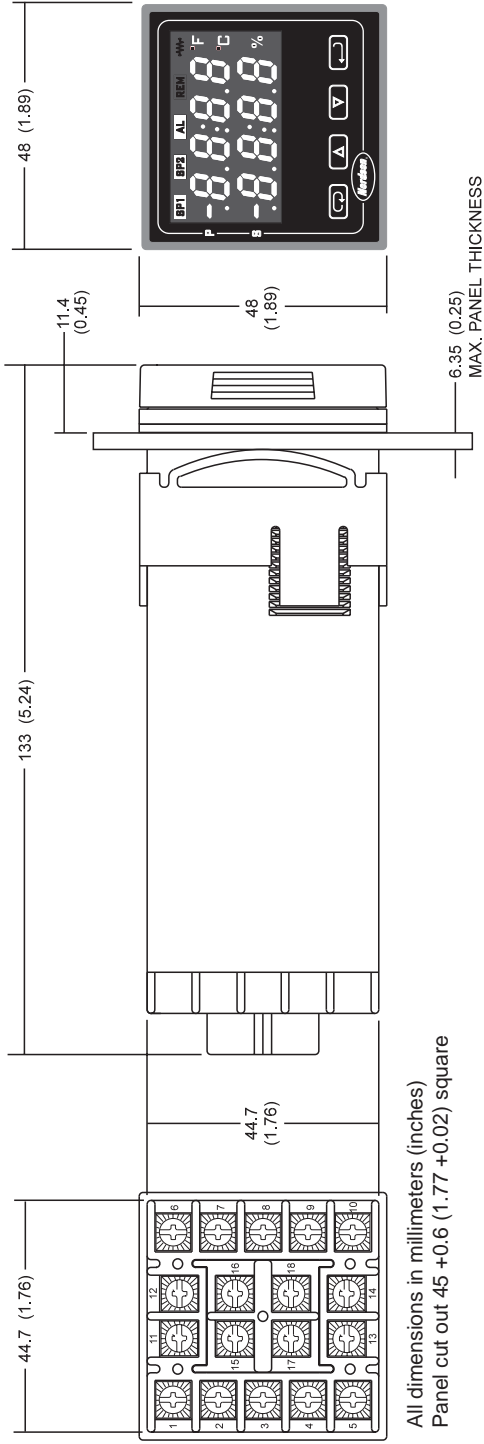

All dimensions in millimeters (inches)  
 Panel cut out 45 +0.6 (1.77 +0.02) square