

Pivot Drum Conveyor Unloader

Description

See Figure 1.

The Pivot Drum Conveyor Unloader is designed to make container changes easier to perform. Spring-loaded locks (1) on both sides of the conveyor keep it stowed in the UP position. The maximum load capacity of the conveyor is 750 lb (340 kg).

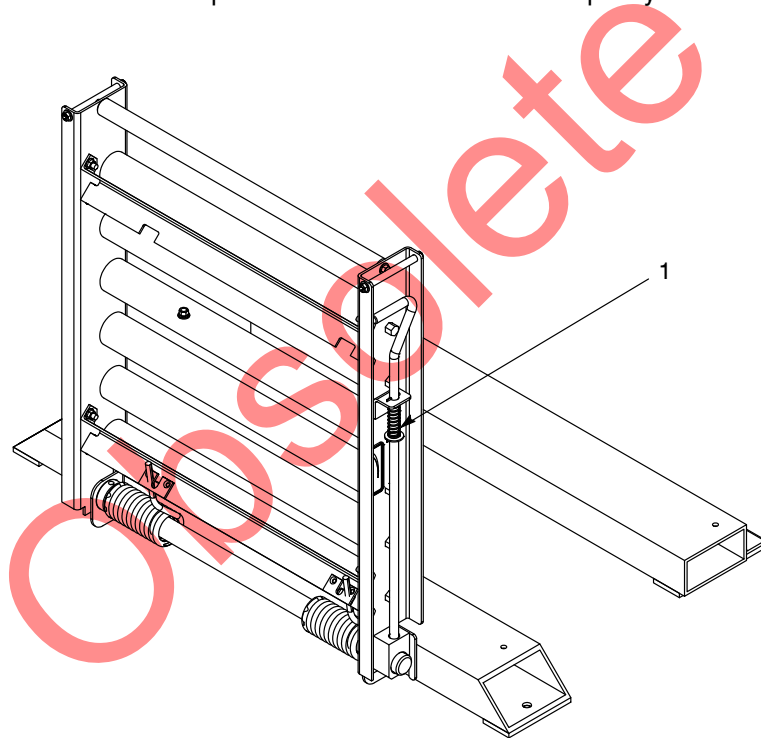

Figure 1 Pivot Drum Conveyor Unloader

Installation



WARNING: Allow only qualified personnel to perform the following tasks. Follow the safety instructions in this document and all other related documentation.

See Figure 2.

1. Lift the bulk unloader sufficiently to slide the front (7) and back supports (6) under the base plate (1) of the bulk unloader, as shown.
2. Apply Loctite 242 to the threads of the screws (2). Secure the front (7) and back supports (6) to the bulk unloader frame (1) using the screws (2), washers (3), lock washers (4), and nuts (5). Tighten the screws to 23 ft-lb (N•m).

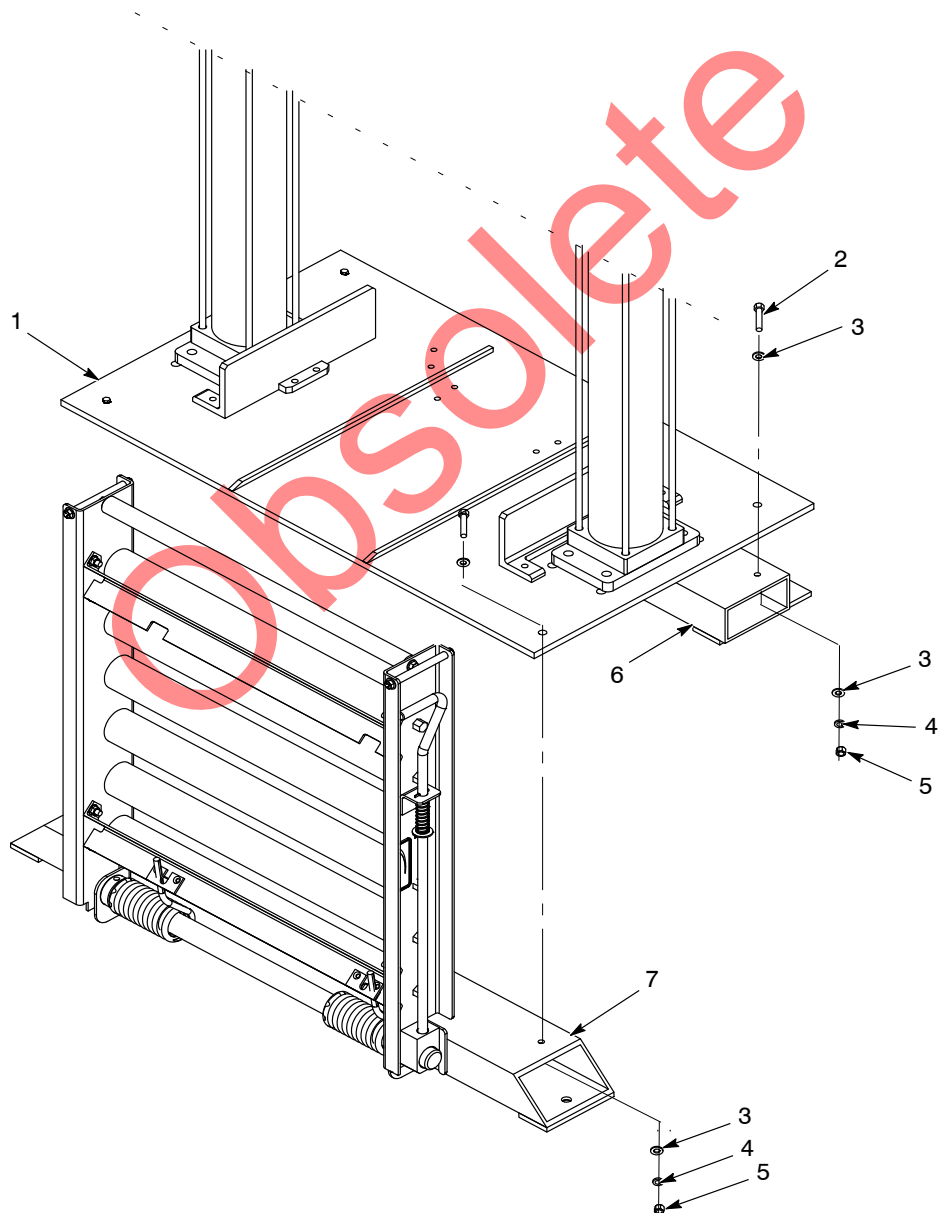

Figure 2 Installation

How to Use the Conveyor

See Figure 3.

NOTE: The maximum load capacity of the conveyor is 750 lb (340 kg).

1. Pull up on the lock handles (2) and swing the conveyor (1) to the DOWN position.
2. Remove the material container from the bulk unloader and place it onto the conveyor (1). Use the conveyor to slide the material container off of the bulk unloader.
3. Place a new material container onto the conveyor (1). Use the conveyor to slide the container into position on the bulk unloader.
4. Swing the conveyor to the UP position. Make sure the lock handles (2) are secured and the conveyor is locked.

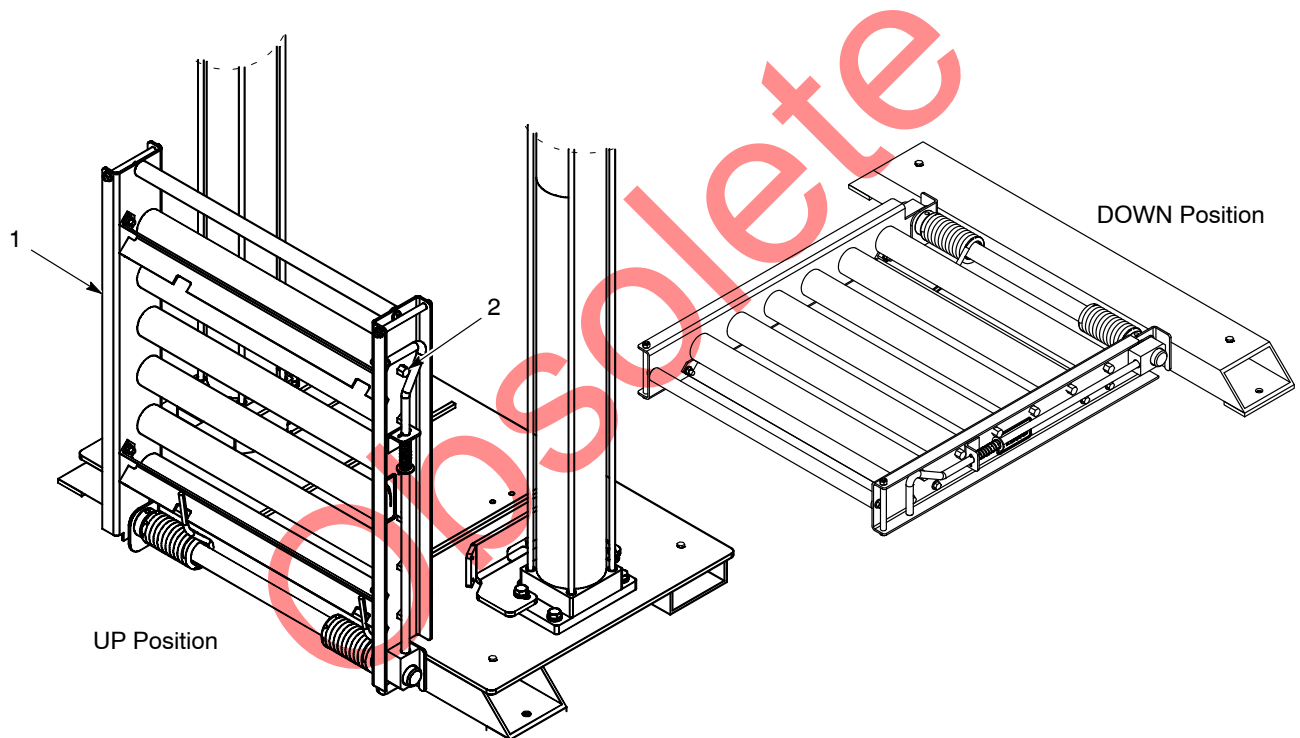

Figure 3 Operating the Conveyor

Parts

To order parts, call the Nordson Customer Service Center or your local Nordson representative.

See Figure 4 and the following parts list.

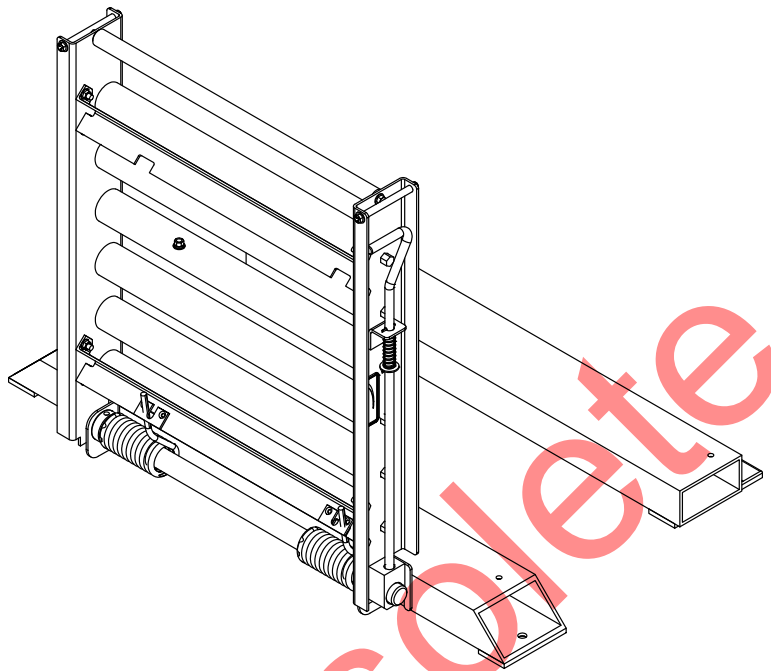

Figure 4 Pivot Drum Conveyor Unloader

Item	Part	Description	Quantity	Note
—	1605341	Conveyor, pivot, drum, unloader – black	1	
—	1606753	Conveyor, pivot, drum, unloader – blue	1	

Issued 4/17

Original copyright date 2017. Nordson and the Nordson logo are registered trademarks of Nordson Corporation.

All other trademarks are the property of their respective owners.