

# Encore<sup>®</sup> Inline Powder Feed Pump



**WARNING:** Allow only qualified personnel to perform the following tasks. Follow the safety instructions in this document and all other related documentation.

## Description

Encore inline powder pumps are used in powder feed centers to draw powder from a container, atomize the powder stream, and transfer it to powder spray guns. The pumps are installed on lance assemblies and can be used with 11-mm (768176) or 1/2-in. (768178) Nordson antistatic powder feed hose.

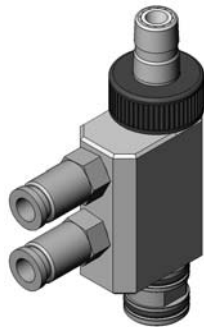

Figure 1 Encore Inline Powder Feed Pump

## Pump Removal



**WARNING:** Place the feed center controls in MANUAL mode to prevent unwanted movement of the lance assembly before performing the following tasks. Failure to observe this warning may result in personal injury.

1. Shut off the spray guns and put the feed center in MANUAL mode, then raise the lance assembly out of the powder container.
2. Blow off the lance assembly and inline pumps.
3. See Figure 2. If used, unclamp the hose manifold (2).
4. Remove the hose manifold, or disconnect the hoses from the pumps, then remove the retainer rod (9).
5. Disconnect the air tubing from the pump flow rate (6) and atomizing air (5) fittings.
6. Pull the pumps (3) off the manifold block (8) with a slight twisting motion.

## Pump Installation

**NOTE:** For best results, the powder feed hose (1) should be no longer than 10.7 meters (35 feet) and rise vertically over its length no more than 3.7 meters (12 feet).

1. See Figure 2. Push the pump (3) into the manifold block (8) until the pump body bottoms out against the block.
2. Connect the flow rate and atomizing air tubing to the flow rate (6) and atomizing air (5) fittings.
3. Install the hose manifold (2) onto the pump venturi throats (4), or install the retainer rod (9), then connect the hoses to the pumps.
4. If used, clamp the hose manifold in place.

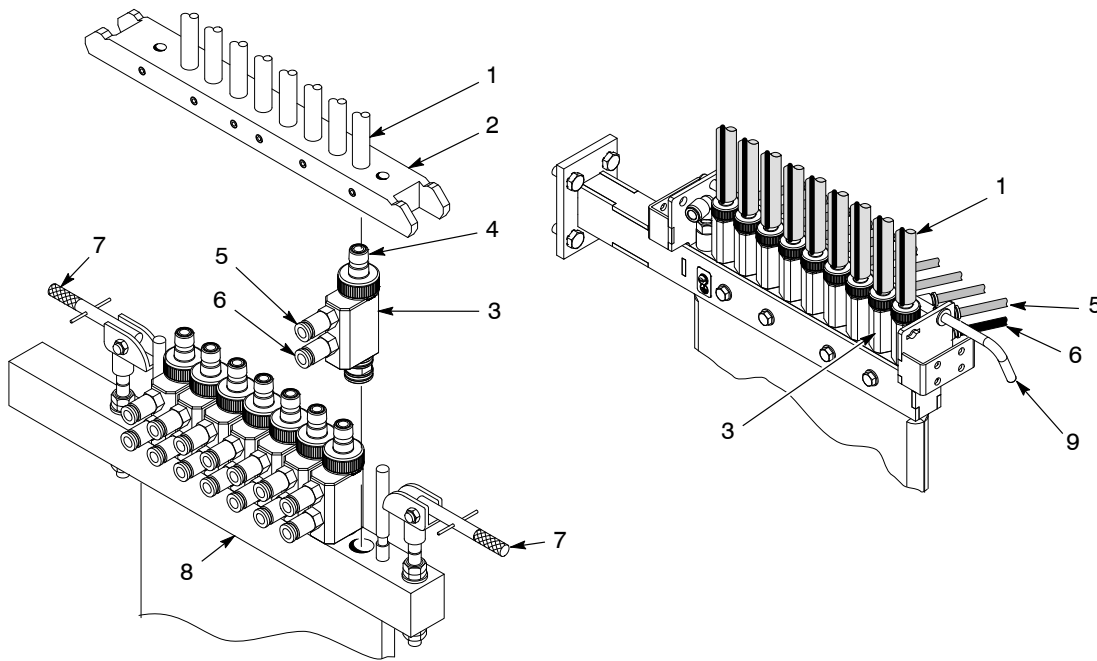

Figure 2 Removing and Installing Inline Pumps on Lance Assemblies – Hose Manifold Version Shown

- |                       |                          |                     |
|-----------------------|--------------------------|---------------------|
| 1. Powder hose        | 4. Venturi throat        | 7. Clamping handles |
| 2. Hose manifold      | 5. Atomizing air fitting | 8. Manifold block   |
| 3. Inline powder pump | 6. Flow rate air fitting | 9. Retaining rod    |

## Operation



**WARNING:** All conductive equipment in the spray area must be connected to a true earth ground. Ungrounded, or poorly grounded equipment can become electrically charged and cause a severe shock or create sparks hot enough to cause a fire or explosion.

Operating air pressures are determined by system variables, including powder feed hose type and size, spray gun type, powder type, conveyor speed, and desired film build.

The following air flows are average starting points. Adjust air flows to achieve the desired powder delivery volume and density.

**Atomizing Air:** 1.7 m<sup>3</sup>/hr (1.0 cfm)  
**Flow-Rate Air:** 2.5 m<sup>3</sup>/hr (1.5 cfm)

## Maintenance



**CAUTION:** Always blow out the powder feed hose from the pump end. Make sure that the booth exhaust fan is operating.



**CAUTION:** Do not scrape impact-fused powder off the pump parts with any sharp or hard tools. Powder will build up in any scratches on the powder contact surfaces, causing impact fusion and pump clogging.

<b>Daily</b>	Purge the pump when performing either a color change or system shutdown. Refer to your powder feed center manual for more information.
<b>Periodically</b>	Periodically disassemble the pump and clean its parts following these guidelines: <ul style="list-style-type: none"> <li>• Use low-pressure compressed air and lint-free cloths.</li> <li>• Inspect all parts and replace any that are worn or damaged.</li> <li>• Clean the parts with an ultrasonic cleaner and an emulsion cleaning solution as described in the <i>Recommended Cleaning Procedure</i>.</li> </ul>

### ***Recommended Cleaning Procedure***

Nordson Corporation recommends using an ultrasonic cleaning machine and Oakite® BetaSolv emulsion cleaner to clean powder pumps.

1. Fill an ultrasonic cleaner with BetaSolv or an equivalent emulsion cleaning solution at room temperature. Do not heat the cleaning solution.
2. Disassemble the pump and remove the O-rings and check valves. Blow off the pump parts.

**NOTE:** Do not allow the O-rings to come in contact with the cleaning solution. Do not immerse the check valves in the solution.

3. Place the pump parts in the ultrasonic cleaner and run the cleaner until all parts are clean and free of impact fusion.
4. Rinse all parts in clean water and dry before re-assembling the pump. Inspect the O-rings and replace any that are damaged.

**NOTE:** The tip of the injector must be clean and undamaged. The injector directs the air flow directly into the center of the venturi throat. Any obstruction or damage to the injector will produce an off-center air stream that wears a non-uniform pattern in the throat and reduces its usable life.

## Pump Repair



**WARNING:** Shut off the spray guns and put the system in MANUAL mode before removing the pump from the lance assembly. Failure to observe this warning may result in personal injury.

Remove the pump from the lance assembly. Refer to pump removal procedures on page 1.

### ***Venturi Throat Replacement***

1. See Figure 3. Unscrew and remove the nut (1).
2. With a slight twisting motion, pull the throat holder and throat (2, 4) out of the pump body (5). Inspect the holder and the two conductive silicone O-rings (3) installed on it for wear or damage. Replace any worn or damaged parts.
3. Install the new throat into the throat holder, then push the throat holder into the body with a slight twisting motion.
4. Install the nut over the throat holder and thread it onto the body. Tighten the nut hand-tight.

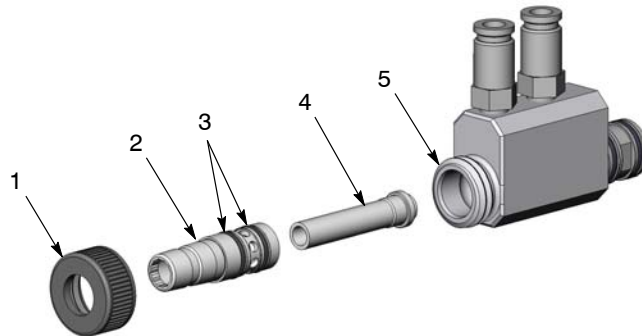

Figure 3 Throat Removal and Installation

- |                  |                                 |              |
|------------------|---------------------------------|--------------|
| 1. Nut           | 3. O-rings (0.489 ID x 0.070 W) | 5. Pump body |
| 2. Throat holder | 4. Venturi throat               |              |

*Note:* All O-rings are conductive silicone. Do not replace with non-conductive O-rings.

### ***Injector Replacement***

This procedure requires a wrench and extraction tool. These tools are optional and must be ordered separately. Refer to *Options* for the part numbers of these tools.

1. See Figure 4. Unscrew the injector adapter (8) from the pump body (5) with a wrench.
2. Insert the extraction tool (11) into the injector (7) and rotate it clockwise to hook the injector spider as shown. Turn the tool clockwise while pulling on it to remove the injector from the pump body.
3. Inspect the injector, injector adapter, and all five O-rings (3, 7, 8, and 9) for wear or damage. Replace any damaged or worn parts.

4. Install two O-rings (3) onto the injector, then press the injector into the pump body, making sure the injector nozzle is pointing toward the output end of the body. The extraction tool can be used to seat the injector fully into the bottom of the pump body bore.
5. Inspect the loose O-ring (3) and make sure it is not damaged or twisted. Insert it into the pump body and seat it against the injector. The end of the extraction tool can be used to make sure it is seated correctly.
6. Make sure the two larger O-rings are installed on the injector adapter. Screw the injector adapter into the pump body and tighten snugly with a wrench.

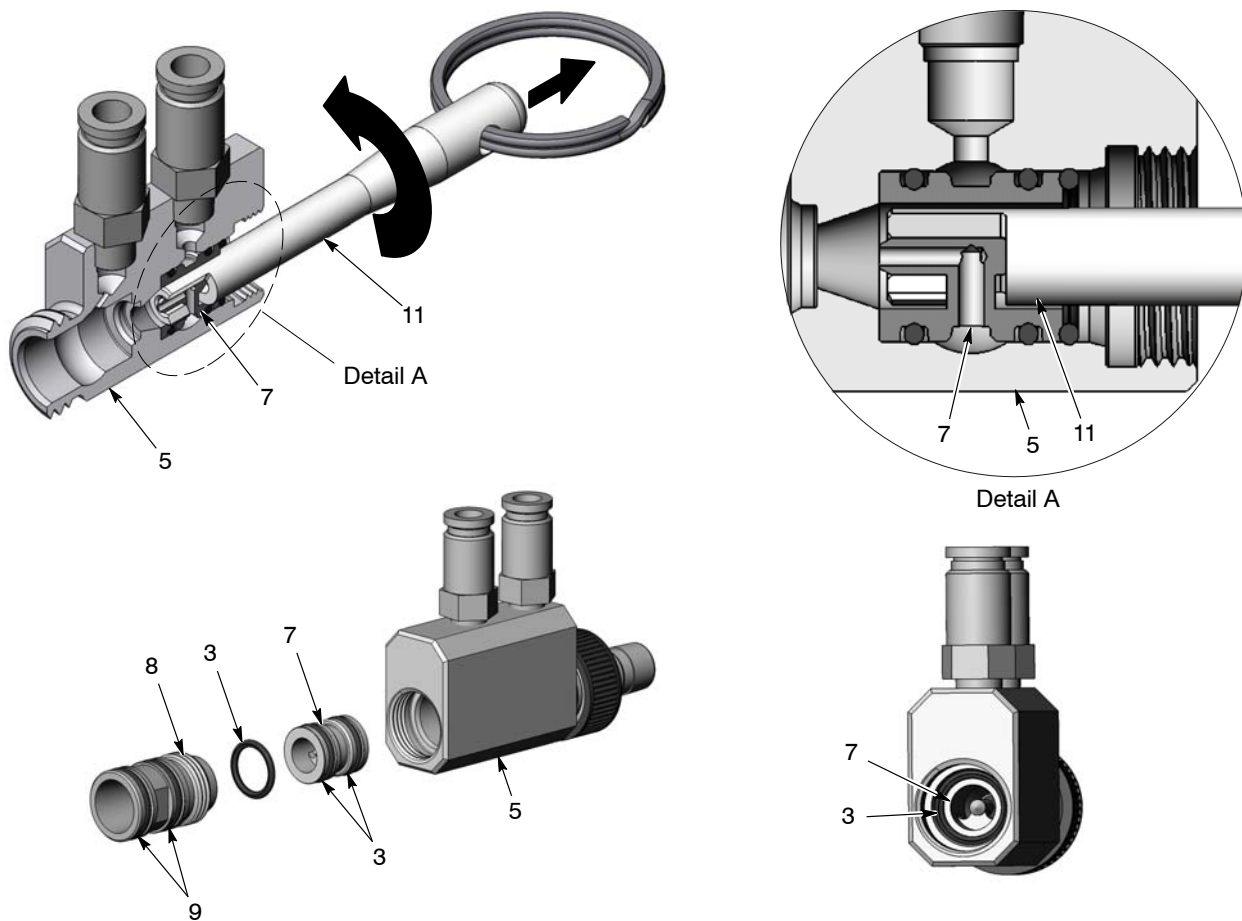

Figure 4 Injector Removal and Installation

- |                                 |                     |                                 |
|---------------------------------|---------------------|---------------------------------|
| 3. O-rings (0.489 ID x 0.070 W) | 7. Injector         | 9. O-rings (0.627 ID x 0.080 W) |
| 5. Pump body                    | 8. Injector adapter | 11. Injector extraction tool    |

*Note:* All O-rings are conductive silicone. Do not replace with non-conductive O-rings.

## Parts

To order parts, call the Nordson Finishing Customer Support Center at (800) 433-9319 or contact your local Nordson representative.

### Pump Parts

Item	Part	Description	Quantity	Note
—	1095926	PUMP assembly, inline, Encore, packaged	1	
1	1095914	• NUT, pump Encore Generation II	1	
2	1095898	• HOLDER, pump throat, Encore Generation II	1	
3	940147	• O-RING, silicone, conductive, 0.489 ID x 0.070 in. wide	5	
4	1095899	• THROAT, pump, Encore Generation II, Tivar®	1	
5	1095915	• BODY, inline pump, Encore	1	
6	344252	• VALVE, check, M8 tube x R 1/8 in., M, output	2	
7	1600594	• INJECTOR, machined, inline pump, Encore, stainless steel	1	
8	1095916	• ADAPTER, injector, inline pump, Encore	1	
9	1088590	• O-RING, silicone, conductive, 0.627 ID x 0.080 in. wide	2	

### Options

Item	Part	Description	Quantity	Note
4	1095910	THROAT, pump, Encore Generation II, PTFE	1	
10	152999	WRENCH	1	
11	1097913	TOOL, extraction, inline pump, Encore	1	

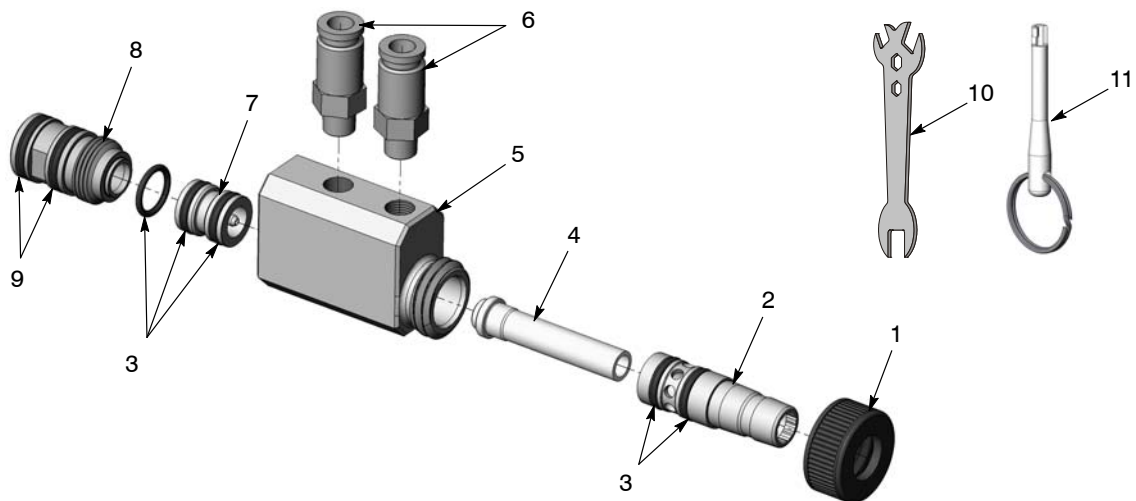

Figure 5 Encore Inline Powder Pump Parts

Issued 01/2014

Original copyright date 2009. Encore, Nordson, and the Nordson logo are registered trademarks of Nordson Corporation. All other trademarks are the properties of their respective owners.