

iControl[®] Configuration Guide

1056418-CG06
Issued 4/13

Updated for iControl Software versions 3.4 and 3.6



Parts and technical support: (800) 433-9319

This manual is available on the internet at <http://emanuals.nordson.com/finishing/>



Nordson Corporation • Amherst, Ohio • USA

Configuration Flowchart

16 = Page Number

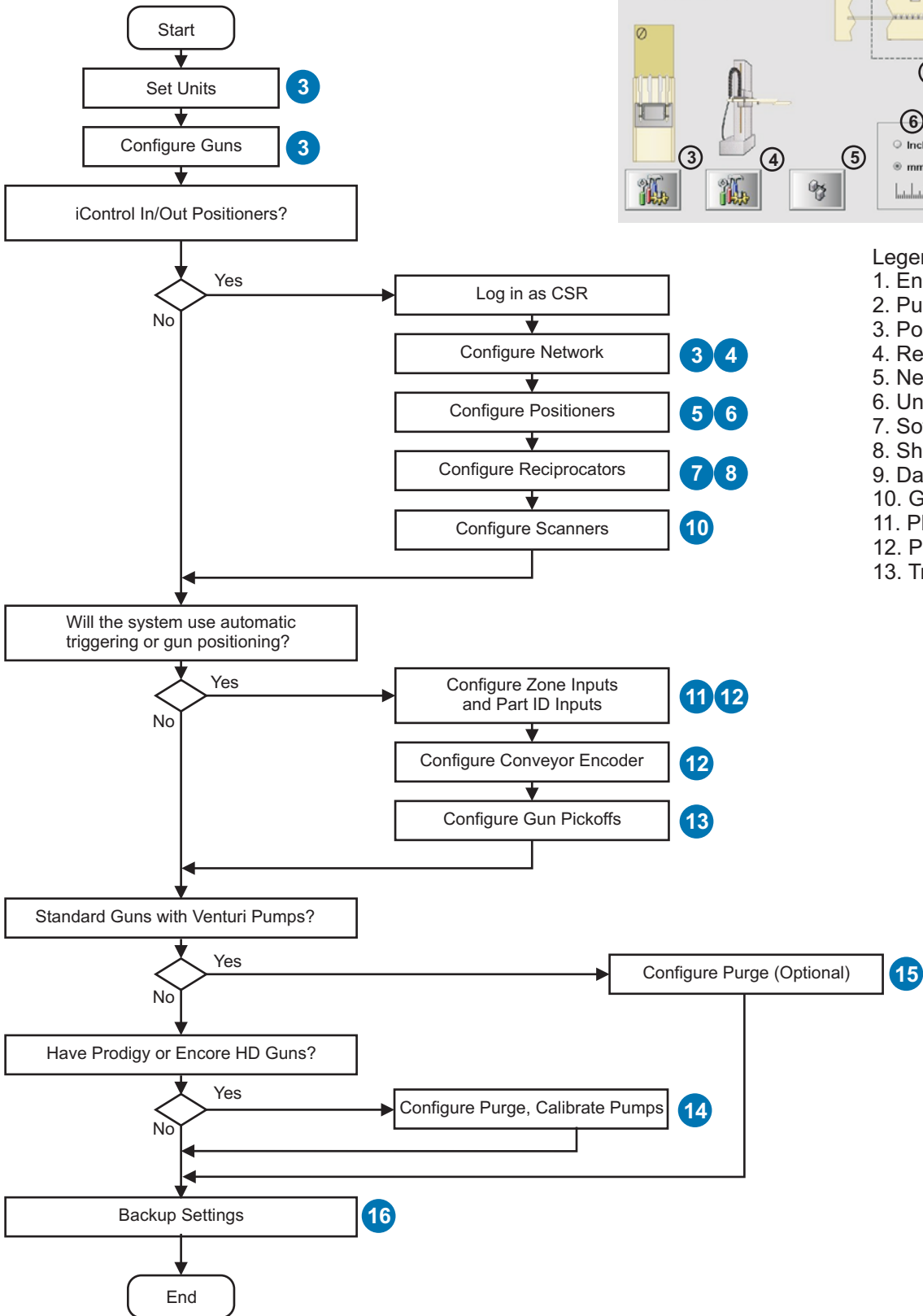
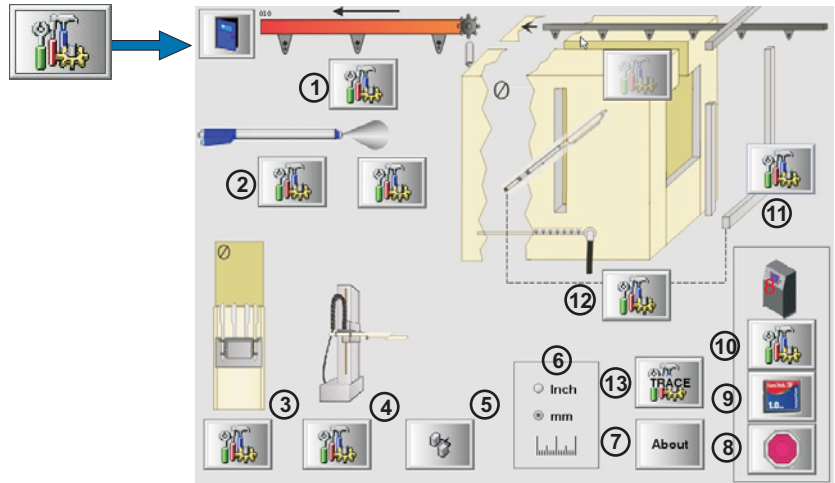

- Legend:
- 1. Encoder
 - 2. Purge
 - 3. Positioners
 - 4. Reciprocators
 - 5. Network
 - 6. Units
 - 7. Software Versions
 - 8. Shutdown
 - 9. Data Backup
 - 10. Guns
 - 11. Photoeyes/Scanners
 - 12. Pickoffs
 - 13. Trace (diagnosis only)

iControl® Configuration Guide

Set Units



Gun Configuration

Number of Guns/Console
 CM: MasterConsole
 CS: Remote Console

I/O Board Type

Manual Mode Lockout Enable and Relay Type

Default Gun Type

HD pump control board version

Select for Spectrum HD Feed Center with Easy Clean Hopper (EU only)

Air Flow Upper Limit

Smart Flow Enable (Venturi Pumps Only)

Network Configuration

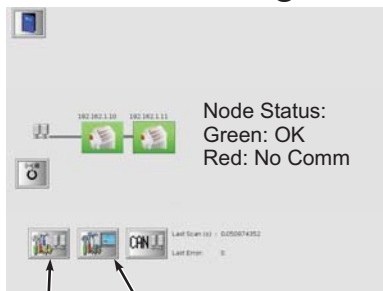

Host Configuration

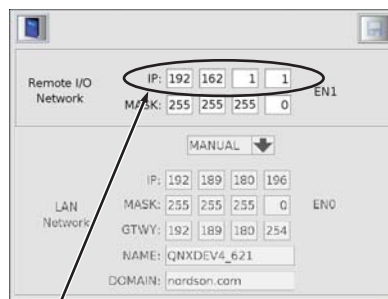

Configure Nodes

Configure Host



Page 4

Set Master Console IP address:

Are there multiple iControl Master Consoles on the same network?

No - Set the IP address to 192.162.1.1

Yes - Is this Master #1?

Yes - set to 192.162.1.1

No - set as follows:

Master #2: 192.162.1.2

Master #3: 192.162.1.3

Master #4: 192.162.1.4

Master #5: 192.162.1.5

and so on.

Maximum: 9 masters

NOTE: Leave Mask set to 255.255.255.0.

The LAN Network settings are for future use.

Network Configuration (continued)

Node Configuration

Enter the following for each node controller on the network:

- MAC address
- TCP/IP address
- Machine type

Configure the controllers for the in/out positioners first, always entering them in numerical order (GP1, GP2, GP3, GP4). If reciprocators are used with positioners, then the system always assumes that reciprocator 1 is mounted on positioner 1. If the system has reciprocators but no positioners, then configure the reciprocators first, always entering them in numerical order (RC1, RC2, RC3, RC4).

When entering the machine type, select the field, then use the rotary dial to toggle through the possible selections:

- GP1 – GP4 (positioners)
- RC1 – RC4 (reciprocator 1)
- GP1_GP2 (positioners 1 and 2)
- GP3_GP4
- RC1_RC2 (reciprocators 1 and 2)
- RC3_RC4
- GP1_RC1 (positioner 1 and reciprocator 1)
- GP2_RC2
- GP3_RC3
- GP4_RC4
- PE (scanners)
- FC (Prodigy feed center)
- BC (booth control, future)
- BE (booth exhaust, future)

Use combinations (GP1_RC1) when one controller controls two machines, such as a positioner and reciprocator.

When complete, touch SAVE.

At 1st message: Turn all node controllers off, then touch CONTINUE.

At 2nd message: Touch CONTINUE.

At 3rd message: Turn all node controllers on, then touch CONTINUE.

If a node is not recognized, check settings and repeat Save.

	MAC						TCP/IP				M	IW	OW								
1	0	:	30	:	DE	:	0	:	33	:	C8	192	.	162	.	1	.	10	GP1_RC1	20	20
2	0	:	30	:	DE	:	0	:	50	:	2A	192	.	162	.	1	.	12	GP2_RC2	20	20
3	0	:	30	:	DE	:	0	:	56	:	6A	192	.	162	.	1	.	13	GP3_RC3	20	20
4	0	:	30	:	DE	:	0	:	68	:	F8	192	.	162	.	1	.	14	GP4_RC4	20	20
5	0	:	30	:	DE	:	0	:	0	:	0	192	.	162	.	1	.	15	PE	20	20
6	0	:	30	:	DE	:	0	:	0	:	0	192	.	162	.	1	.	16	FC	0	0
7	0	:	30	:	DE	:	0	:	0	:	0	192	.	162	.	1	.	0		0	0
8	0	:	30	:	DE	:	0	:	0	:	0	192	.	162	.	1	.	0		0	0
9	0	:	30	:	DE	:	0	:	0	:	0	192	.	162	.	1	.	0		0	0
10	0	:	30	:	DE	:	0	:	0	:	0	192	.	162	.	1	.	0		0	0

MAC Address
On controller label

TCP/IP Address
Must be unique unless it is shared
Suggested:
1st node, master 1: 192.162.1.10
1st node, master 2: 192.162.1.20
NOTE: A shared controller such as a part ID device (PE) must be assigned the same IP address on all master consoles.

Machine Type

In/Out or Up/Down Positioner Configuration

1. Select positioner to configure. Repeat these steps for each positioner:

2. Select side of booth positioner is located on. Positioner numbers on Main screen will change to match this setting. Control screen for Positioner 1 will control physical positioner 1 if node configuration was done in correct order.



3. If positioner will only be operated manually:
 3a. Set to Off.
 3b. Set encoder resolution to 1.
 3c. Press Enter to enter value in database. Perform steps 10 and 11e (set to Clean Only).

3. If positioner will be operated automatically:
 3a. Set to Off.

3b. Set Encoder resolution:
 Rack and Pinion: 262
 Belt Driven: 224
 Analog Retrofit: 1
 Other: Refer to drawing/name plate.

Perform steps 4 to 11, then set leads and lags for minimum and default.

4. Set Zero and Home positions:

- Set to Manual
- Jog forward toward part to front limit switch 
(3d should read 0)
- Jog reverse away from part to rear limit switch 
(3d should read maximum travel distance)

If position (4d) does not display as expected make corrections to limit switch positions and repeat steps b and c.

5. Set Gun Separation:

Side by side arrangement, measure outside to outside. Single stack, measure gun width.

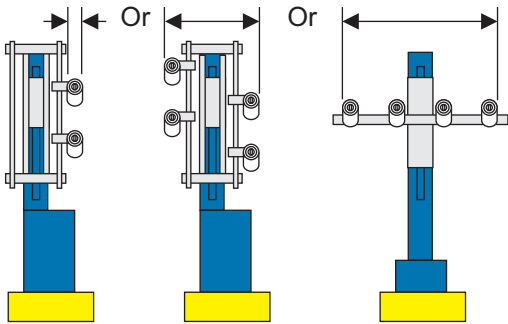

6A. In/Out Only - Set Gun to Conveyor Centerline:

Jog positioner forward to limit switch. Measure gun tip to centerline.

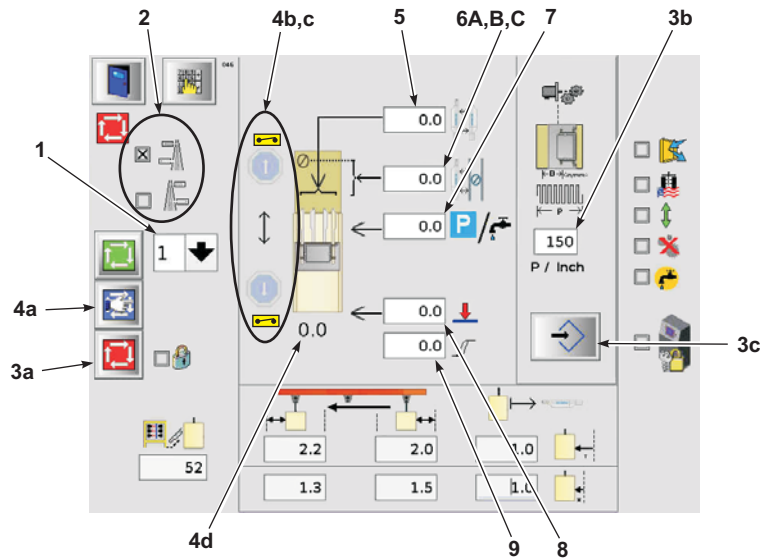
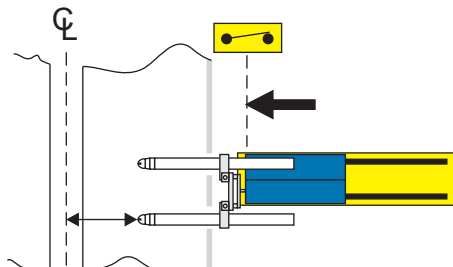

6B. Up/Down (Top-Down) Only - Set Gun to End of Scanner:

Jog positioner down to limit switch. Measure gun tip to bottom beam of scanner.

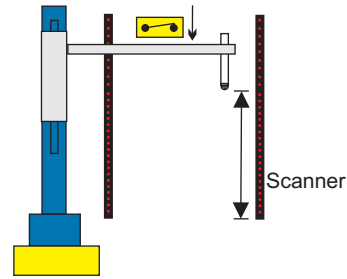

6C. Up/Down (Bottom-Up) Only - Set Gun to End of Scanner:

Jog positioner up to limit switch. Measure gun tip to top beam of scanner.

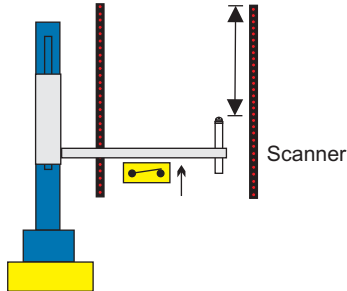

7. Set Park/Clean Position:

Measured from forward limit. Use to move guns out of way of parts. First position in cleaning sequence (Europe).

- Version 2.2: Position to move to if taken out of Auto mode, or if exhauster shuts off or network lost.
- Version 2.4: Added Park button functionality to move to this position.

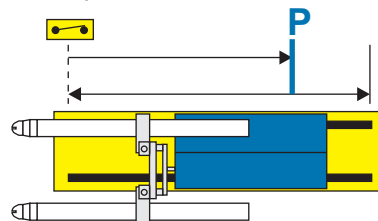

In/Out or Up/Down Positioner Configuration (continued)

8. Set Retract Position. This is:

- Start position for Lance moves.
- Position to move to if no position value available at start up.
- For Analog Retrofits: Retract position, must equal measured maximum travel.

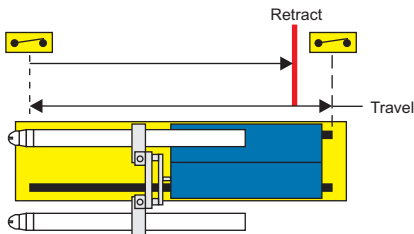

9. Set Hysteresis:

Stop compensation. Prevents hunting for target position. If the positioner stops within \pm hysteresis value of the target then it does not attempt to move to the target. Typical value is 1 or less.

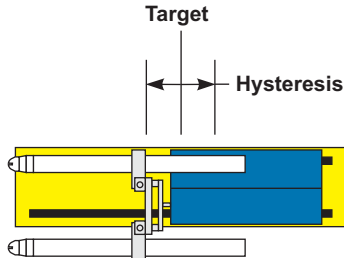

10. Pickoff:

Distance from the scanners to the leading edge of the leading gun.

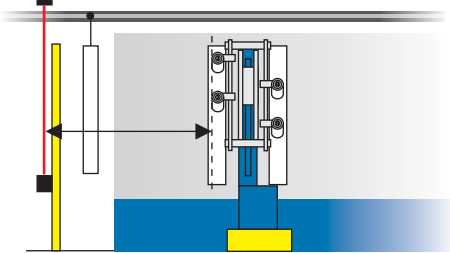

11. Options:

- Lance: Positioner starts moves from Retract Position.
- USA ColorMax: Sets the cleaning sequence for a US-designed ColorMax spray system.
- Y-Axis: Select when positioner moves guns vertically instead of horizontally. Choose Top-Down or Bottom-Up next to the Side of Booth selection.
- No Drive: Positioner has reversing contactors for direction control, no speed controller. (Europe)
- Clean Only: Manual control positioner only, used to move guns out of booth for cleaning. Default and Preset Move settings ignored.

12. Lockout Override:

Use this setting to override the lockout keyswitch.

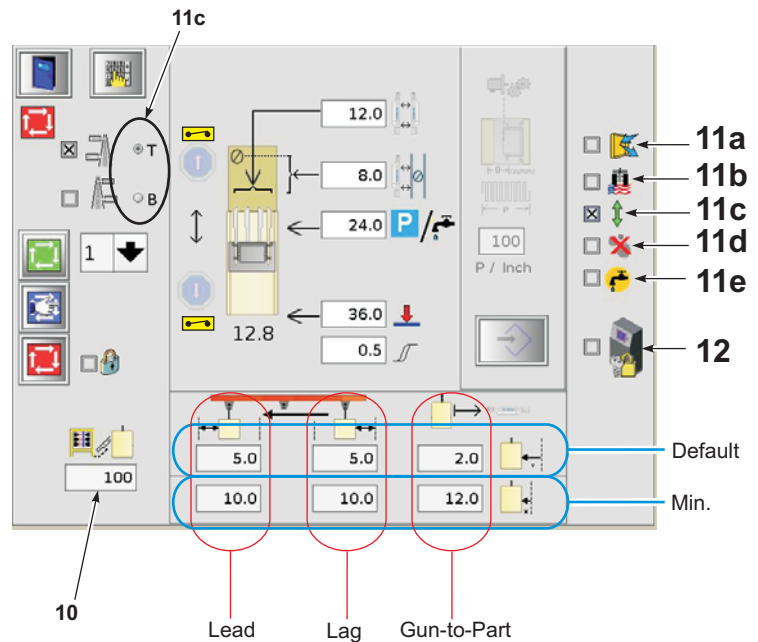

Automatic Gun Positioning

Set Default and Minimum Lead, Lag, and Gun-to-Part distances. These are application-specific settings.

Default Settings: Used for all parts unless positioner preset settings have been programmed for a part. Positioner uses Gun-to-Part setting to follow part contour, moving at lead and lag settings.

Minimum Settings: Used to prevent collisions between parts and guns. Minimum settings limit positioner preset settings.

Settings

Positive Lead: Causes positioner to move **before** leading edge of part reaches first gun.

Negative Lead: Causes positioner to move **after** leading edge of part reaches first gun.

Positive Lag: Causes positioner to move **after** trailing edge of part reaches first gun.

Negative Lag: Causes positioner to move **before** trailing edge of part reaches first gun.

Gun-to-Part Distance: Distance to maintain between gun tip and part. Positioner uses this setting to follow part contour.

Reciprocator Configuration

1. Select reciprocator to configure.

Repeat these steps for each reciprocator.

2. Set operating mode to OFF.

3. Set side of booth.

4. Set encoder resolution and press Enter.

5. Set maximum speed.

6. Set turn-around offset (procedure on next page).

NOTE: Turn-around Offset and Accel/Decel are mutually exclusive. If you set a value for one function, you must set the other to zero. Use Accel/Decel only when the recip. Wago controller software is ver. 17 or above.

7. Set Acceleration/Deceleration time. This must be exactly the same as the VFD setting.

8. Set fan pattern width (width of one gun's fan pattern, or if patterns overlap, average width).

9. Set number of laps. (Number of times the fan width passes over a point) 2 - standard quality 4 - medium quality 6 - fine quality

NOTE: You can use the lap calculator to help find the optimum setting. Refer to the Operator Card.

10. Set gun numbers. Enter beginning and ending gun numbers.

11a. Set top soft limit.

11b. Set bottom soft limit. Measured from the Home (0.0) position. (Home is approximately 25 mm below the top limit switch). During normal operation the limit switches should not be tripped.

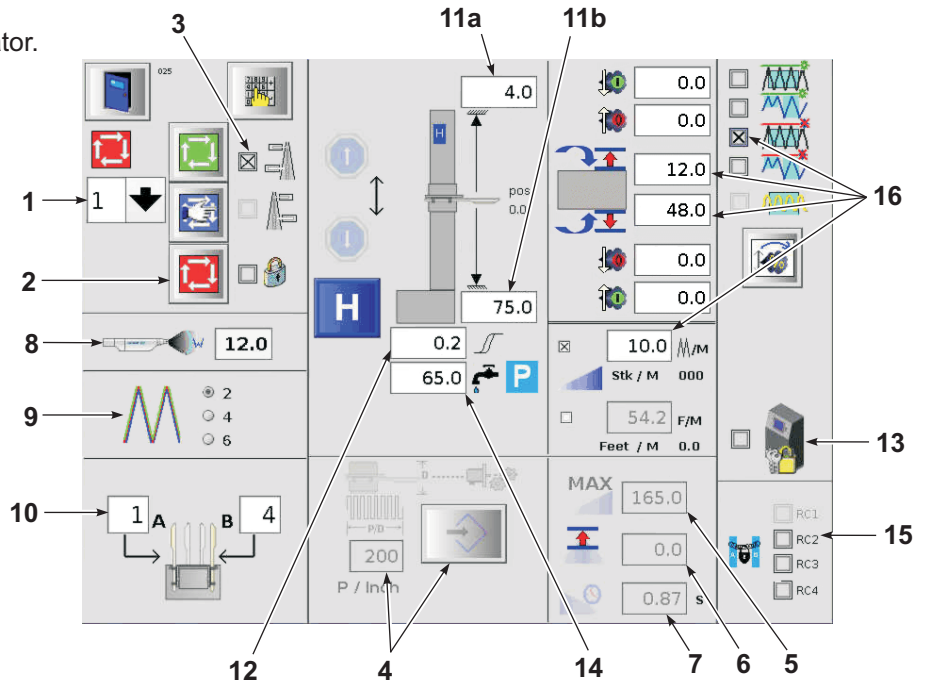
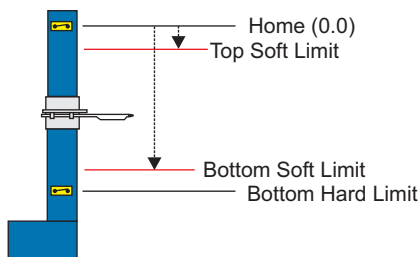

12. Set Hysteresis:

Stop compensation. Prevents hunting for Park position. If reciprocator stops within \pm hysteresis value of the Park position then it does not move again. Typical value is 1 or less.

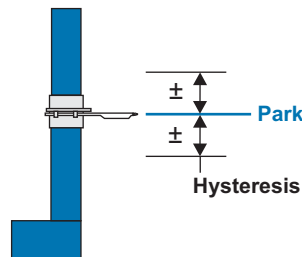

13. Lockout Override:

Overrides keyswitch lockout so reciprocator can be moved while guns are locked out.

14. Set Park/Clean Position:

Measured from the Home position (0.0). (Home is approximately 25 mm below the top limit switch.) Position to move to at beginning of cleaning cycle.

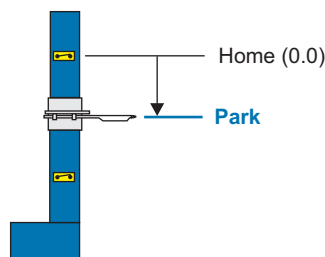

15. Set Slaves for Current Reciprocator:

Selected reciprocators become slaves to the current reciprocator (Step 1). In the screen shown on this page, reciprocator 2 is slaved to reciprocator 1.





Reciprocator Configuration (continued)

16. Turn-Around Offset:

- The turn-around offset corrects for overtravel at the turn-around points.
- Select Fixed, No Synchronization mode.
 - Touch the Home button.
 - Move the carriage down by hand until the current position reads 4 inches.
 - Make reference marks on the carriage and housing.
 - Set the Top Turn-Around to the current position.
 - Move the carriage down until the current position is 4 inches from the Bottom Soft Limit.





- Make a reference mark on the housing aligned with the mark on the carriage.
- Set the Bottom Turn-Around to the current position.
- Set the speed to 50% of maximum.
- Select Auto mode and note where the actual turn-around occurs.
- Enter the estimated distance between the actual turn-around and the mark on the housing into the Turn-Around Offset field. Adjust as necessary.

14. Set motion mode:

-  Fixed, conveyor synchronization
-  Variable, conveyor synchronization
-  Fixed, no synchronization
-  Variable, no synchronization
-  Oscillator



If a synchronization mode is selected, then the reciprocator speed is calculated using the conveyor speed, along with the mode settings.

Oscillator Mode

-  To use the the Oscillator mode select a Fixed mode and the Oscillator mode.
-  The selected Fixed mode trigger points are deactivated and the spray guns are triggered on and off by the Spray Preset lead and lag settings only.
-  Reciprocator speed can be set in this mode.
- 
- 

Reciprocator Speed

The speed setting is only active for unsynchronized motion modes, since in synchronized mode reciprocator speed is dependent on conveyor speed. Speed can set in feet/minute (meters/minute), or in strokes/minute.

10.0  **Strokes per minute**
 54.2  **Distance per minute**
000 **Stk / M**
0.0 **Feet / M**

Fixed Mode

Stroke length is controlled by turn-around points, without regard for part height. Gun trigger points are controlled to vary the spray length with the part height. Gun trigger points can be positive or negative. **NOTE:** You can use the lap calculator to help find the optimum setting. Refer to the Operator Card.



Gun On - Downstroke



Gun Off - Upstroke



Top Turn-Around



Bottom Turn-Around



Gun Off - Downstroke



Gun On - Upstroke

Reciprocator speed can be set for fixed, unsynchronized mode.

Fixed Mode Positive Gun Trigger Settings

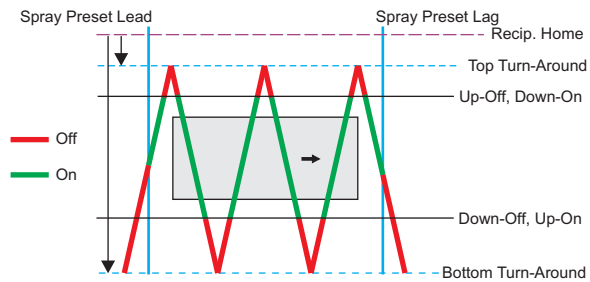

Fixed Mode Negative Gun Trigger Settings

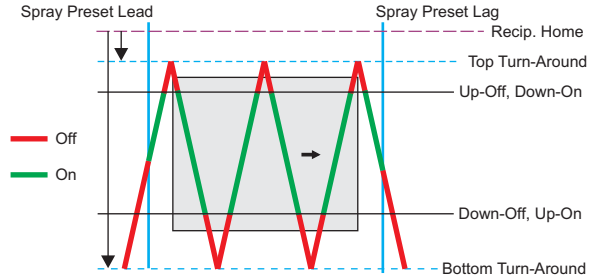

Reciprocator Configuration (continued)

Variable Mode

In Variable mode, the reciprocator stroke length varies according to the part dimensions. The turn-around settings determine the reciprocator stroke length when no part is in front of the guns, while the overtravel limits determine the stroke when a part is in front of the guns. The overtravel settings can be positive or negative.

NOTE: You can use the lap calculator to help find the optimum setting. Refer to the Operator Card.

	0.0	Top Turn-Around
	6.0	Top Overtravel
	68.0	Bottom Overtravel
	0.0	Bottom Turn-Around

Variable Mode Positive Gun Trigger Settings

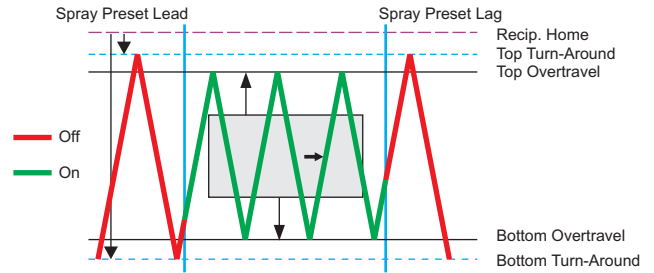

Variable Mode Negative Gun Trigger Settings

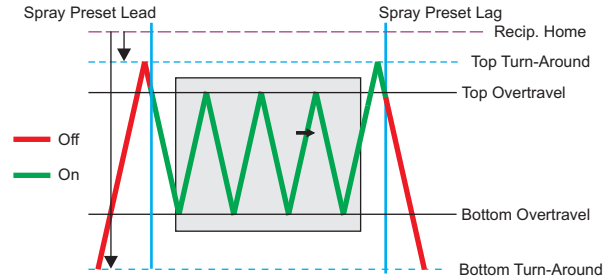

Reciprocator Percent Adjust

	0-7.9 in	8-15.9 in	16-23.9 in	24-31.9 in	32-39.9 in
	0%	0%	0%	0%	0%
	0%	0%	0%	0%	0%
	0%	0%	0%	0%	0%
	0%	0%	0%	0%	0%

This function allows you to control powder pump flow-rate and atomizing air flow based on stroke length. It can only be used with the two variable stroke modes.

This function changes flow-rate and atomizing air by percentages as the stroke length increases or decreases. As the reciprocator is commanded to a given stroke length the change is sent to the gun control cards associated with the reciprocator. This function only supports a configured single row of guns on a reciprocator.

NOTE: Percent Adjust is an additive variable. These Percent-Adjust settings are added or subtracted from Reciprocator Preset Percent Adjust settings, Global Percent-Adjust settings, and Conveyor Speed Percent-Adjust settings.

Height/Width Scanner Configuration

These scanners are used to measure the part dimensions for in/out positioners and reciprocators.

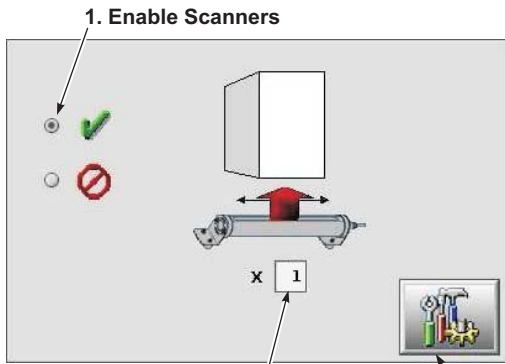

2. Number of Horizontal Scanners (Single Scanner Configuration) 3. Configure

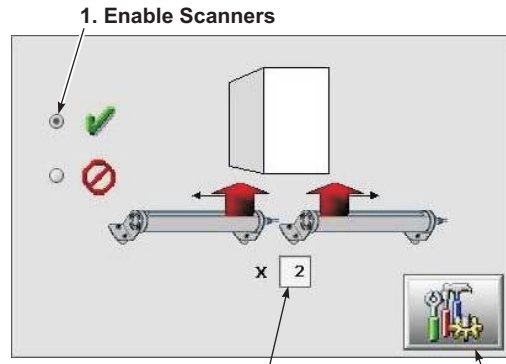

2. Number of Horizontal Scanners (Dual Scanner Configuration) 3. Configure

NOTE: If using a single scanner mounted to one side of the conveyor centerline, use the Dual Scanner configuration.

Single Horizontal Scanner

Configure scanner to ignore the conveyor (requires laptop, cable, and manufacturer software).

Make the following settings:

1. Length of horizontal scanner.
2. Width of conveyor left and right of scanner centerline.
3. Distance from cable end to conveyor centerline.
4. Length of vertical scanner (if used).
5. Vertical Offset: Distance from zero position of guns to top scanner beam.
6. Scanner beam resolution.
7. Zero offset.

Dual Horizontal Scanners

Make following settings:

1. Length of scanners.
2. Scanner ends to conveyor centerline.
3. Length of vertical scanner (if used).
4. Vertical Offset: Distance from zero position of guns to top scanner beam (for reciprocators only).
5. Scanner resolution.
6. Zero offset.

Scanner beam resolution

Select 3/4 in. or 3/8 in. This presets the noise compensation to 10% of a single beam voltage. This value varies with the scanner length and resolution. A 72 inch scanner:

- at 3/4 in. has 96 beams with 0.1 volt per beam.
- at 3/8 in. has 192 beams with 0.052 volt per beam.

Zero Offset Setting

Zero offset is used to tune out noise and ambient signals from analog inputs. When the system is powered up the initial values for LBB and FBB should be zero. Any noise or ambient signal will result in LBB and FBB changing to some value. To tune out the signal, enter values in the LBB and FBB fields (Z) slightly larger than the signal values. For example, if the LBB value is 125 then enter 130 in the LBB field.

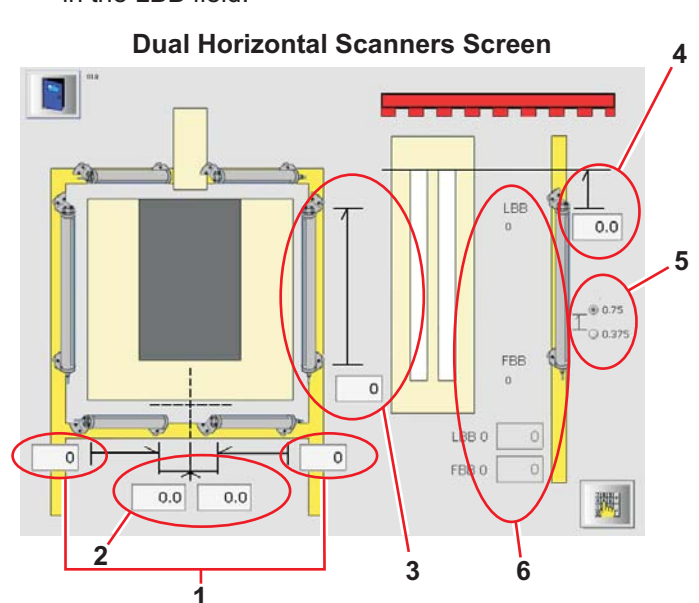
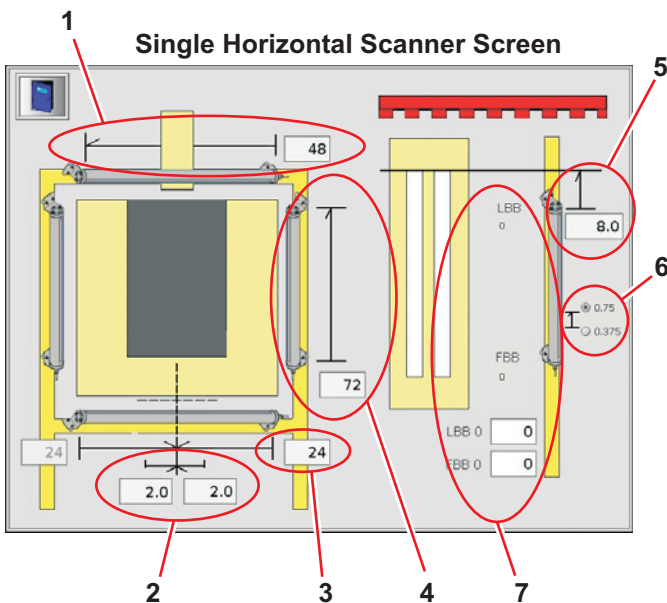

Zone Inputs Configuration

Discrete (Digital) Scanners or Photoeyes

1. Select PE and set the number of zones.
2. Set a Zone Filter if desired. Positive value increases detected length; negative value decreases detected length.

Analog Scanner

1. Go to the Configure Analog Scanners procedure on the previous page and set the length of the vertical scanner.
2. Select DIM, then the Configure button.
3. Enter the length of each zone, measured from the top of scanner to the bottom of each zone.
3. Set Zone Filter if desired. Positive value increases detected length; negative value decreases detected length.
4. Set Auto-Zero, if desired, so that scanner ignores non-parts in zone 1: Move a part carrier or hanger in front of the scanner, then touch the Auto-Zero button. At end of countdown offset value is set.

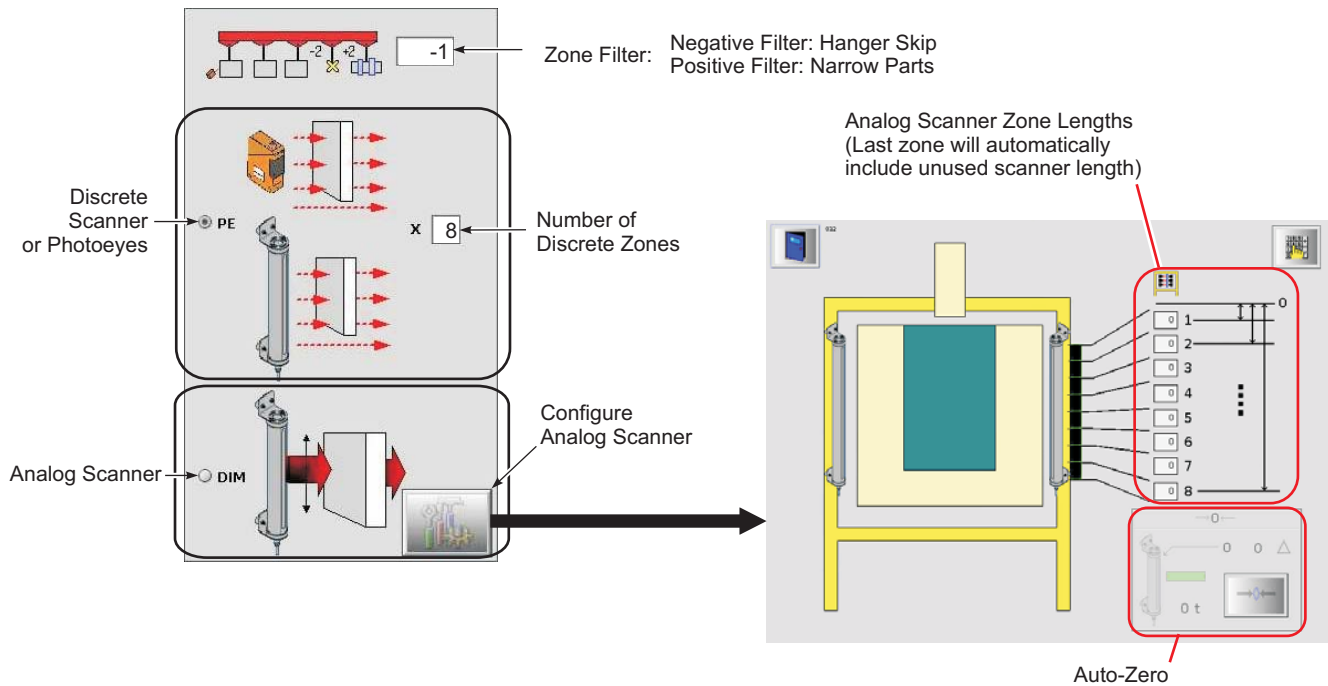

Using Zone Inputs for Direct Triggering

Allows an external controller, connected to the zone inputs, to trigger the spray guns immediately upon the change in state of a bit or series of bits. The iControl console acts like a simple gun controller without the need for a conveyor encoder, or zone photoeyes or scanners.

To switch to this mode, select the **Dir** option on the Zone/Part ID Configuration screen. Refer to the Installation section of your iControl hardware manual for the I/O board inputs.

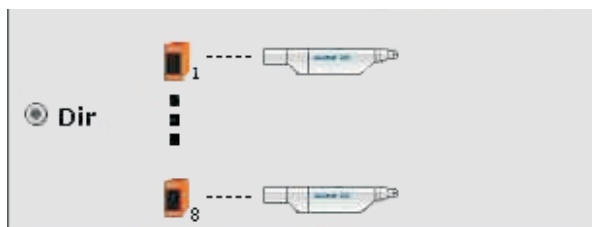

Input 17	Input 18	Guns
0	0	1-8
1	0	9-16
0	1	17-24
1	1	25-36

The zone inputs 1-8 on the I/O board trigger 1-8 guns. Inputs 17 and 18 control the gun banks as shown in the table. Input 19 functions as the input strobe, or enable input. When input 19 is turned on the active inputs between 1 and 8 trigger the guns. When the strobe is turned off the guns remain triggered on until the strobe is turned back on.

Part ID Input Configuration

Select flagging method.

Set flag filter if using part ID flags.

The flag filter is the travel length in which a valid part ID signal must be received before the part ID is read.

NOTE: Part ID input devices must not detect parts or hangers unless they are intended to trigger a part ID change.

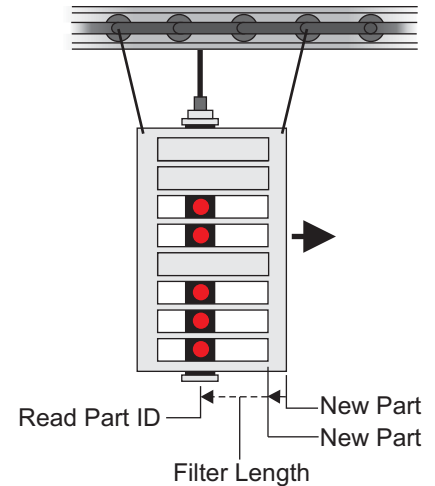
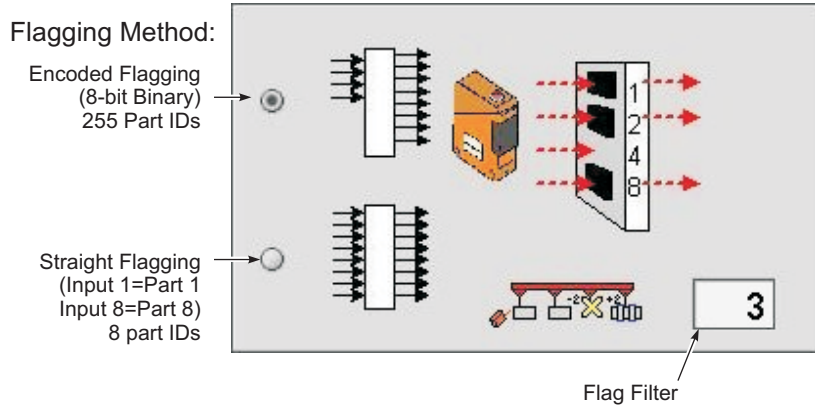

Conveyor Encoder Configuration

If You Know the Resolution:

1. Enter the resolution in Box 3.
2. Select the entered value.
3. Touch the Enter button.

To Teach the Resolution:

1. Hang a piece of cardboard or a part 36 inches or longer on conveyor.
2. Enter the length in Box 1.
3. Touch the Reset button in Box 2 to reset the counter..
4. Run the cardboard or part past the zone photoeyes, or scanners, then stop the conveyor. The calculated resolution appears in Box 3.
5. Select the calculated resolution.
6. Touch the Enter button.

Encoder Pulse Configuration

X2: Multiplies the encoder pulses by 2, for a finer resolution and more accurate triggering.

÷2: Divides the encoder pulses by 2, for a coarser resolution. you can also choose to multiply the encoder pulse by 2 or divide by 2 for finer or coarser resolution.

X1: Uses the encoder pulses as is. This is the default configuration.

Clock Option:

Select the CK (clock) option and enter the conveyor speed to run the system without an encoder.

Refer to the iControl Operator

Interface manual for information on how to use this function correctly.

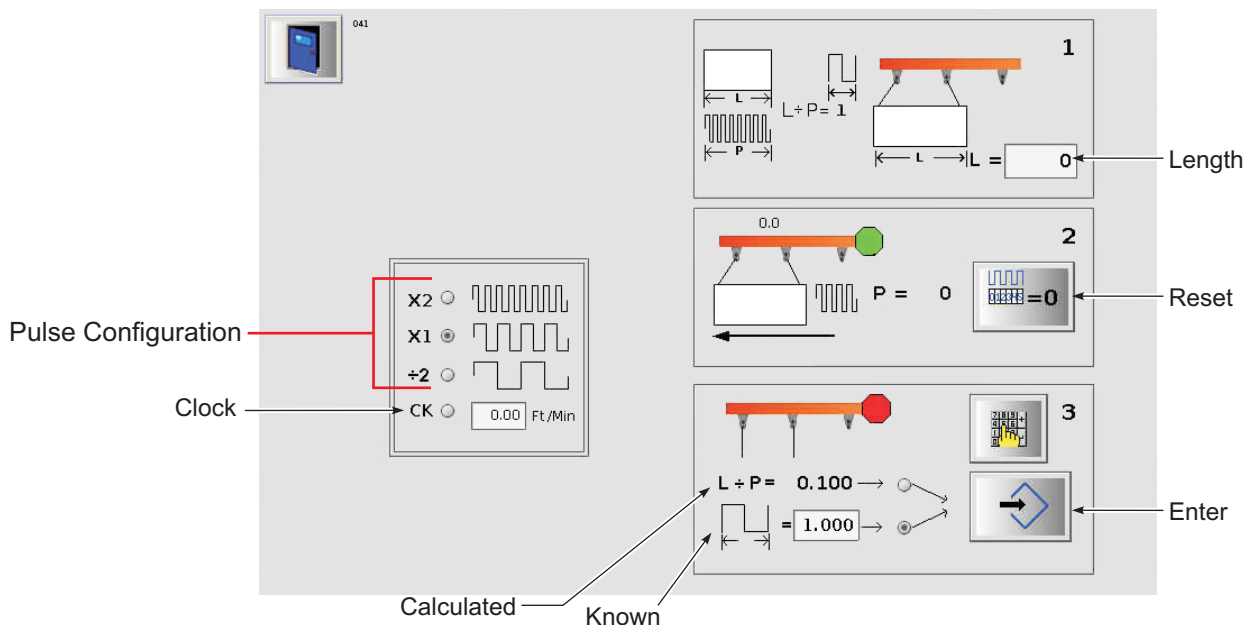

Spray Gun Pickoff Configuration

1. Measure from zone photoeyes or scanners to gun tips and enter in pickoff fields.
2. Measure from the zone photoeyes or scanners to the exit end of the booth and enter in booth length field.

Shift Register Reset

Reversing the direction of the conveyor causes the system to lose track of parts that have passed the zone photoeyes or scanners. Resetting the shift register clears all parts out of the system.

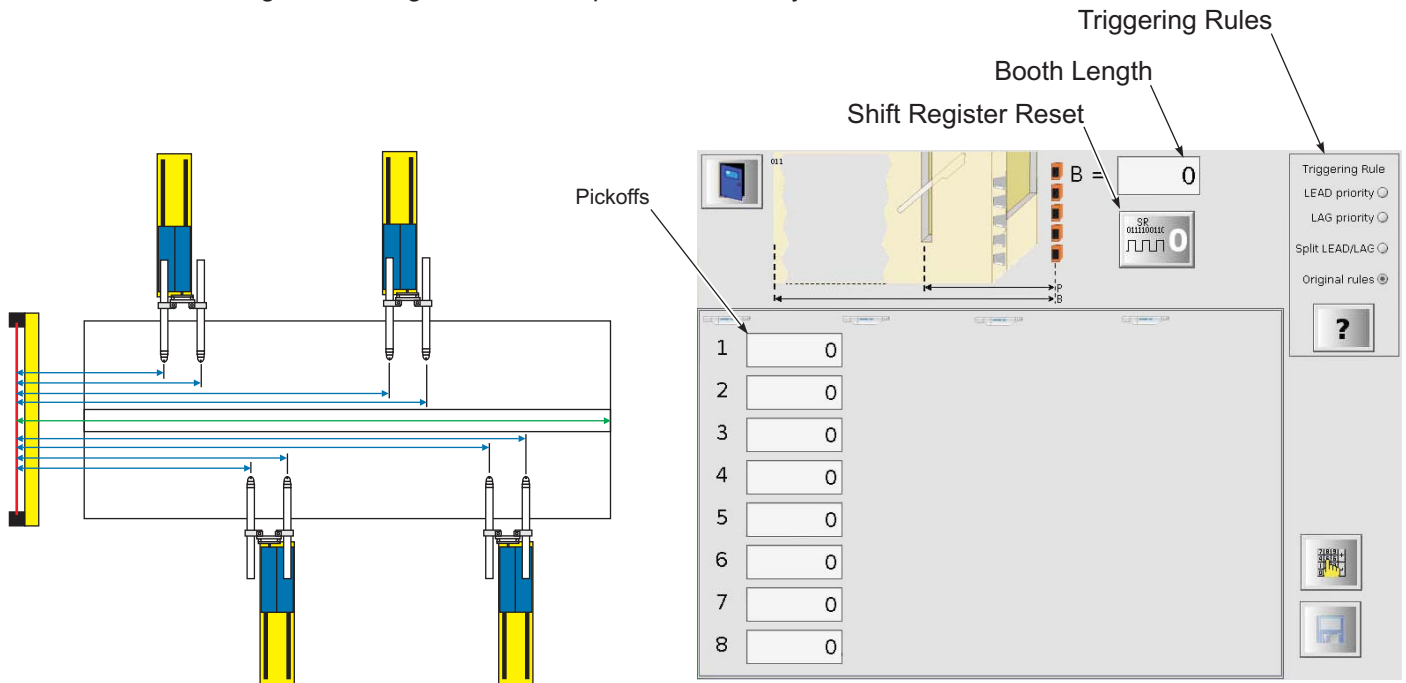

Triggering Rules

Original Rule: (Default rule) The preset of a new part takes priority.

Lead Priority: The lead of the next part will not start until the trailing edge of the previous part is reached, if the new lead overlaps the previous part.

Lag Priority: The lag of the previous part continues until complete or the leading edge of the next part is reached.

Split Priority: The lead of the next part overlaps the lag of the previous part, the lead and lag are split evenly.

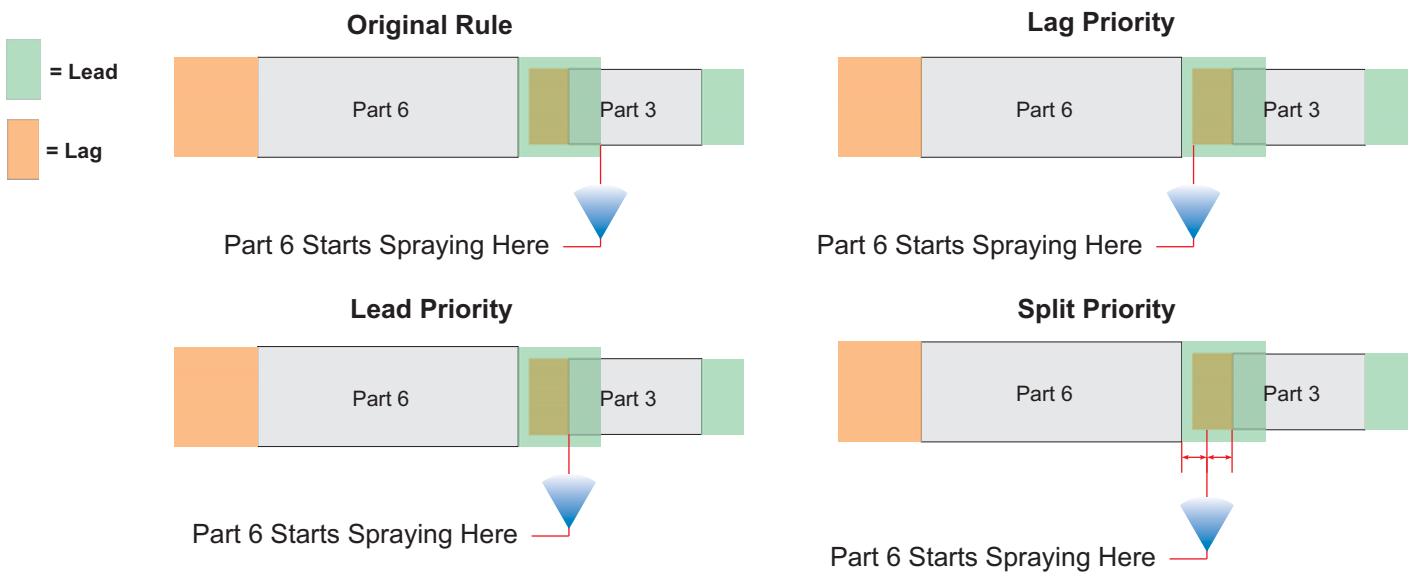

Prodigy Gun Purge Configuration

Gun purging takes place automatically as part of the cleaning cycle in a color change process, which is initiated by the feed center controls. Gun purging can also be controlled manually by the operator, using the Prodigy Purge Control screen on the Main screen.

The default purge method is all guns at once. You can also group the guns into banks and purge the banks separately, depending on your system's hardware configuration.

The purge sequence consists of a purge cycle followed by a pulse cycle:

1. Purge Cycle: For the number of seconds specified (duration), assist air is directed through the pump and siphon tubing back to the powder supply (Siphon), then through the pump and delivery tubing to the spray gun (Gun).

2. Pulse Cycle: For the number of pulses specified, purge air is directed in pulses, from the pump to the powder supply (Siphon), then from the pump to the spray gun (Gun).
Pulse On sets the pulse duration;
Pulse Off sets the time between pulses.

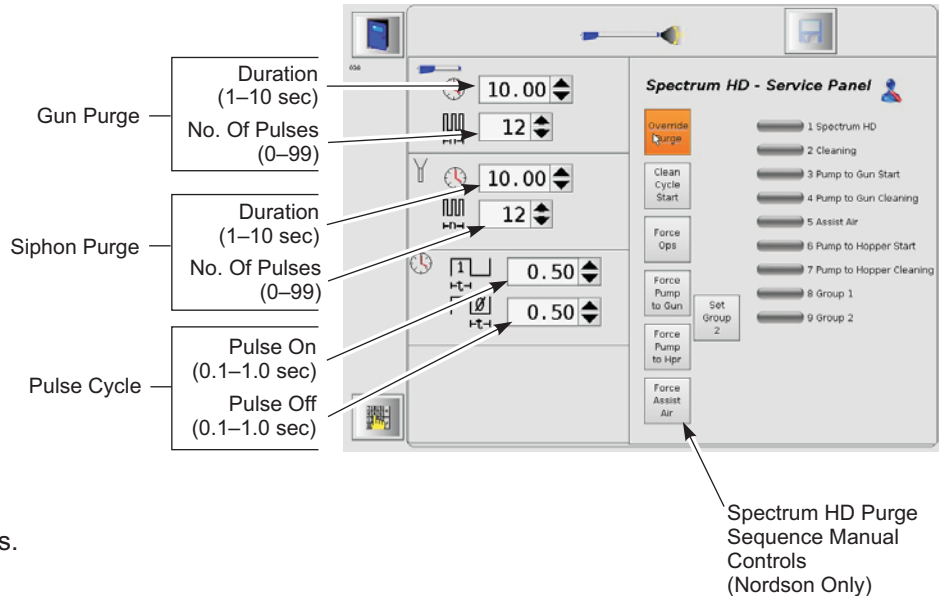

Prodigy HDLV Pump Calibration

Each Prodigy spray gun is supplied by a separate HDLV pump/manifold assembly. The calibration numbers for Pump and Pattern A, B, and C calibration constants are on the pump manifold label. Enter the calibration numbers for each Prodigy HDLV pump into the Calibration screen.

1. Select spray gun number 1.
2. Enter the calibration numbers on the pump manifold label for the gun 1 pump.
3. Touch Send.
4. Repeat for the remaining spray gun/pump combinations.

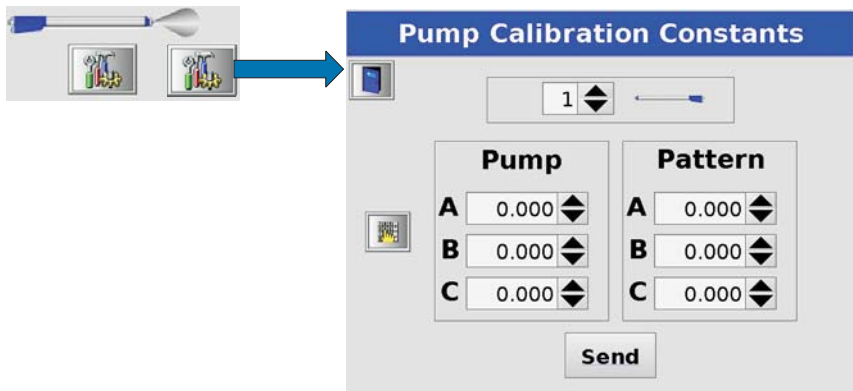

Standard Gun Purge Configuration (Optional)

For Sure Coat, Versa-Spray, and Tribomatic Guns. Only one purge mode should be set for any system.

Evacuation Purge

Can be used with all standard gun types. Uses atomizing air or diffuser air for soft purge. Purge starts when spraying stops. **DO NOT USE** with In-line pumps.

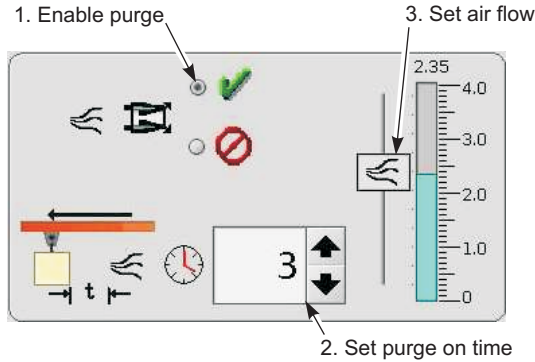

Soft Start

Can be used with all standard gun types. Ramps up air flows to minimize surging. May require increasing lead to compensate for light powder flow at beginning of spray.

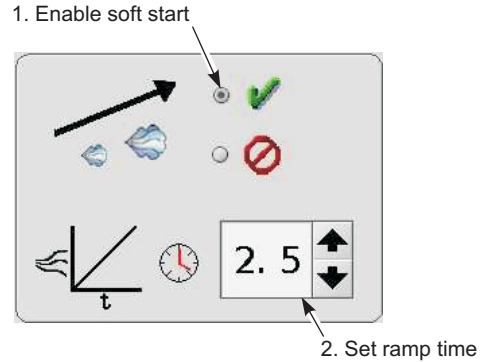

Configure Versa-Spray® Nozzle Purge

To use, install purge adapter kits on guns and single or dual solenoid kits in iControl consoles.

1. Enable purge.
2. Set purge ON time (0–30 sec).
3. Set purge DELAY (0–99 inches) (0–2515 mm).
4. Set minimum LINE GAP (0–240 inches) (0–6096 mm).
5. Set number of purge banks.
6. Assign guns to purge banks.

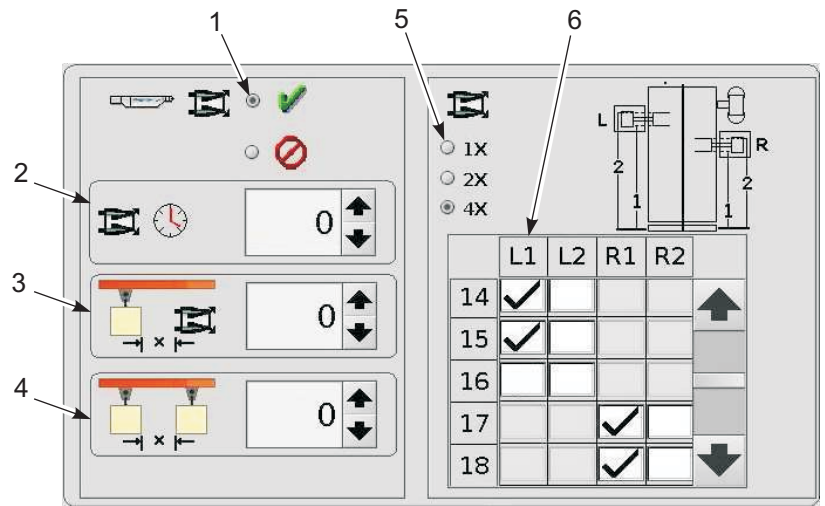

Possible Banks and Bank Designations

1 Console, 1 Single Purge Kit
1 Bank

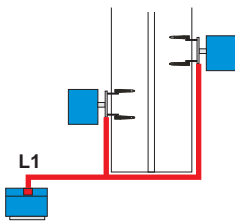

1 Console, 1 Dual Purge Kit
2 Banks

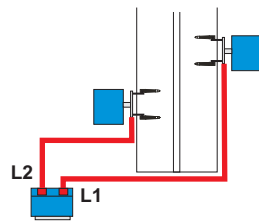

2 Consoles, 2 Single Purge Kits
2 Banks

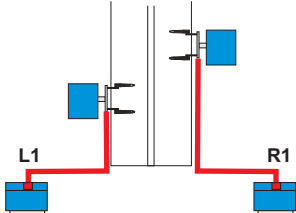

2 Consoles, 2 Dual Purge Kits
4 Banks

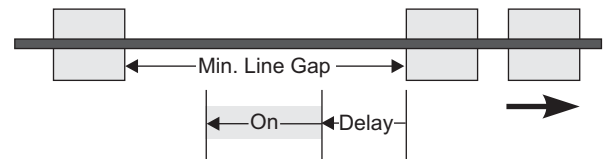
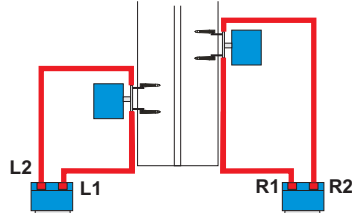

System Testing

Set up at least one spray preset, then test the spray gun triggering to ensure that the guns are triggering on and off as expected. Adjust the encoder resolution if necessary.

If the system includes positioners, test their operation with the guns shut off, using a flat panel. Simulate part width by blocking the width scanners for the length of the panel.

If the system includes reciprocators, test their operation with the guns on, using a flat panel.

Set up spray, positioner, and reciprocator presets as required.

Back up all settings by copying them to a new Compact Flash card.

Backup

The Backup process copies the configuration and preset settings to a new Compact Flash card. Label the original card and store it in a safe place away from any magnetic devices.

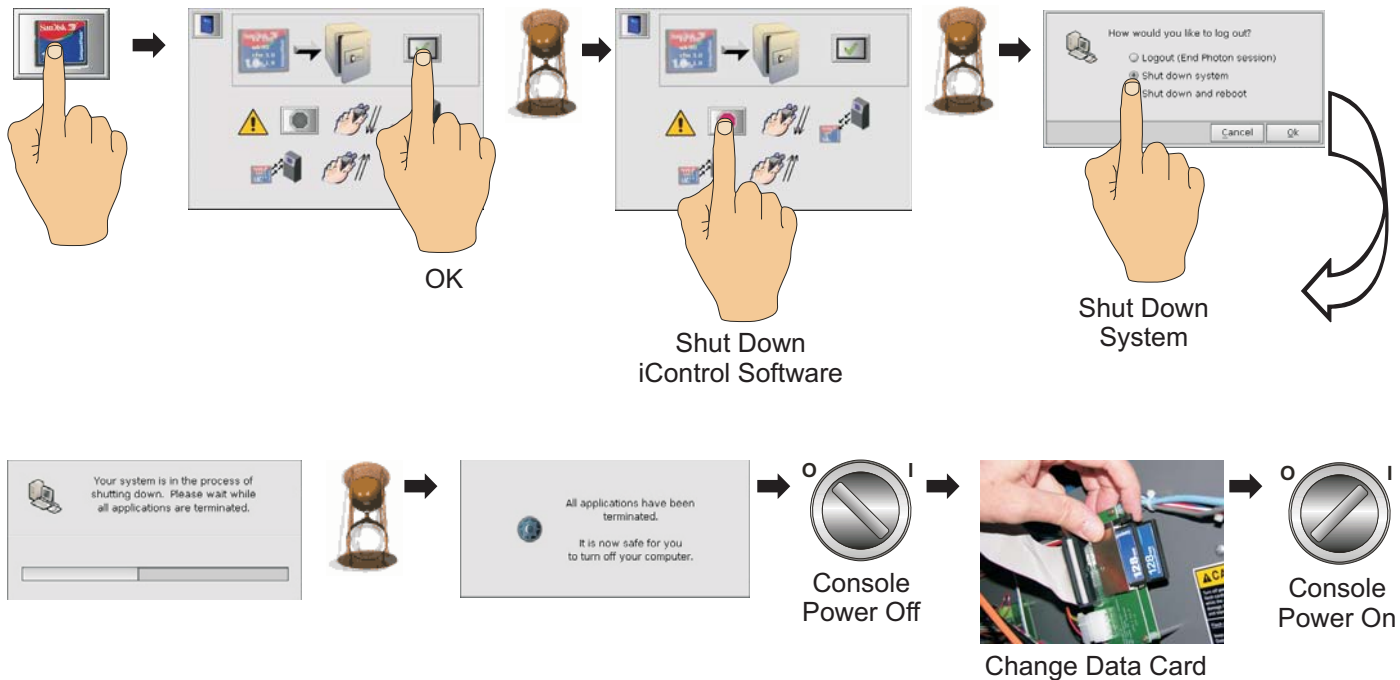

Desktop Utilities

The operating system desktop is visible when the iControl user interface is shut down. From the desktop you can select a series of utilities, change certain configuration settings, and perform restart and shutdown procedures.

CAUTION: Do not make changes or use utilities that are not described in this manual without first consulting with a Nordson controls engineer.

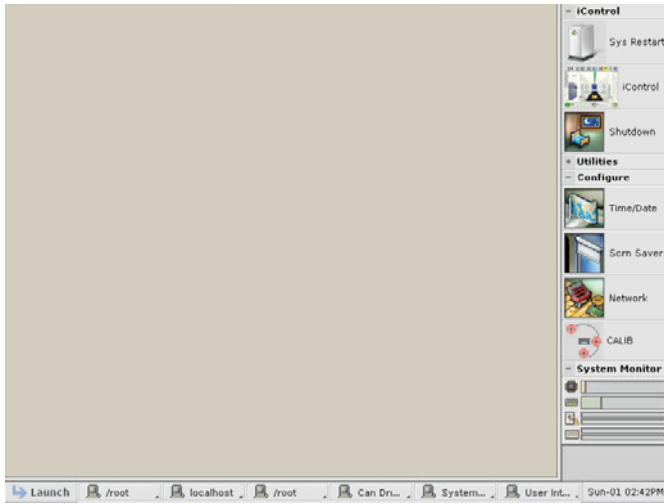

Launch: The Launch button opens a menu with the functions that are available on the sidebar.

Other Taskbar Buttons: The buttons on the bottom of the desktop are minimized application windows that may be used to view diagnostic or status information for selected programs.

Sys Restart: Performs a restart of the primary iControl program and user interface. The only program that remains running is the CAN driver.

iControl: Performs a restart of the iControl user interface only.

Shutdown: Displays the Shutdown dialog and allows you to shutdown the system.

Utilities: Displays a menu of file system tools. These tool should only be used with the direction of Nordson technical support.

Configuration: Displays a menu of configuration tools. These tools should only be used with the direction of Nordson technical support.

Time/Date: Use this utility to set the system time and date.

Screensaver: Use this utility to enable or disable the screen saver and power saver. The default settings are screen saver disabled and power saver set to shut off the LCD backlights after 1 hour of no activity. Touching the screen will turn on the backlights and make the screen visible again.

NOTE: If a system failure should occur when the screen backlights are off, the screen will not turn back on. If this happens you must cycle console power to restart the system. Instruct all operators on the operation of the screen saver. The power saver can be disabled by "unchecking" the screen shutdown option on the power saver tab.

Network: Provides access to Ethernet settings. Most settings are typically configured from the iControl user interface, but this utility includes specialized settings. These settings should only be changed with the direction of Nordson technical support.

Calib: Starts the touch screen calibration process. Refer to Touch Screen Calibration on the following page.

System Monitor: Indicates status of system components.

Touch Screen Calibration



Use the calibration procedure to recalibrate your touch screen.
The calibration values are stored on the program card.

- If you install a program card that has not been used before there will be no calibration file on the card, so the system will automatically start the calibration procedure on bootup.
- If you install a program card that was previously used on another iControl console, you **MUST** perform the Calibration with a Mouse procedure in the iControl hardware manual 1044158 or 1056419.

Touch the CAL (previous versions) or CALIB button to start the procedure. The calibration instructions appear on the screen. Follow the instructions exactly.

NOTE: If the targets are not responsive, there may be a problem with the touch screen hardware. If you do not follow the calibration instructions exactly, you will not be able to touch the center Completion or Accept button and exit the calibration procedure. If this happens, stop and wait until the procedure times out and restarts. You should then be able to repeat the procedure and complete it correctly.

The complete procedure times out in 90 seconds. If you do not touch the Completion or Accept button within 10 seconds of pressing the third target the procedure will restart.

Nordson Corporation
Amherst, Ohio 44001
www.nordson.com

Technical Manuals for Nordson products can be found on <http://emanuals.nordson.com>

© Copyright 2013 Nordson Corporation
All Rights Reserved

No part of this document may be photocopied, reproduced, or translated to another language without the prior written consent of Nordson Corporation. The information contained in this publication is subject to change without notice.

Nordson, the Nordson logo, iControl, Tribomatic, and Versa-Spray
are registered trademarks of Nordson Corporation