

Horizontal Mount Cartridge Filters

Installation Guide for Nordson High-Efficiency, Heavy Duty, and PowderGrid® Filters

Procedure



WARNING: Allow only qualified personnel to perform the following tasks. Follow the safety instructions in this document and all other related documentation.

NOTE: This installation guide is for horizontal mount cartridge filters only. If your Nordson powder coating system uses cartridge filters that are vertically oriented or stacked, refer to your powder coating system manual.

1. Remove and properly dispose of the old cartridge filters. Refer to your powder coating system manual for removal procedures.

NOTE: Keep all of the hardware and the tension rod to install the new cartridge filter.

NOTE: Do not install damaged cartridge filters. If the filter was damaged during shipment, contact the freight carrier. Otherwise, contact your Nordson representative.

2. Inspect each new cartridge filter for damage including:
 - Nicks or cuts in the rubber gasket
 - Tears or holes in the filter media
 - Bent or dented end caps
 - Dented screens caps

3. See Figure 1. Check the end pusher plate (1). If it is...

Attached to the collector module wall with the torque screw (2), nut (5) and hex cap screw (6):

Skip to step 4.

Not attached to the collector module wall:

- a. Apply a few short beads of sealant around the recessed diameter of the closed, concave end of the closed-end cartridge filter.
- b. Place a clean end pusher plate in the recess and allow the sealant to cure long enough to hold the pusher plate in place.

4. Install the closed-end cartridges by resting them on the support rods in the collector module. Push the cartridges against the collector module wall.
5. Install the flow-through cartridges so the ungasketed end butts up against the gasketed end of the closed-end cartridge. The gasket on the opposite end of the flow-through cartridge will be compressed against the color module tube sheet.
6. Install the tension rods with the screws (3) and washers (4).



CAUTION: Do not overtighten the torque screw. Filter damage may occur.

7. Tighten the torque screw until each gasket is compressed to $\frac{7}{16}$ in.
8. Check the alignment of the cartridges and use a feeler gauge to check the gasket compression.
9. Replace the baffles, if used, and the expanded metal grating over the cartridges.

Parts

See Figure 1.

Item	Part	Description	Quantity
1	174546	PLATE, end pusher	1
2	174548	SCREW, hex head, 1/2-13 x 4 in., cap, special	1
3	981619	SCREW, hex head, 7/16-14 x 3/4 in.	2
4	983248	WASHER, flat, 7/16 in.	2
5	984162	NUT, hex, jam, 1/2-13, steel	1
6	981211	SCREW, hex, 1/4-20 x 0.750 in., cap, zinc	1
NS	211229	SEALANT, Lexel	AR

AR: As Required

NS: Not Shown

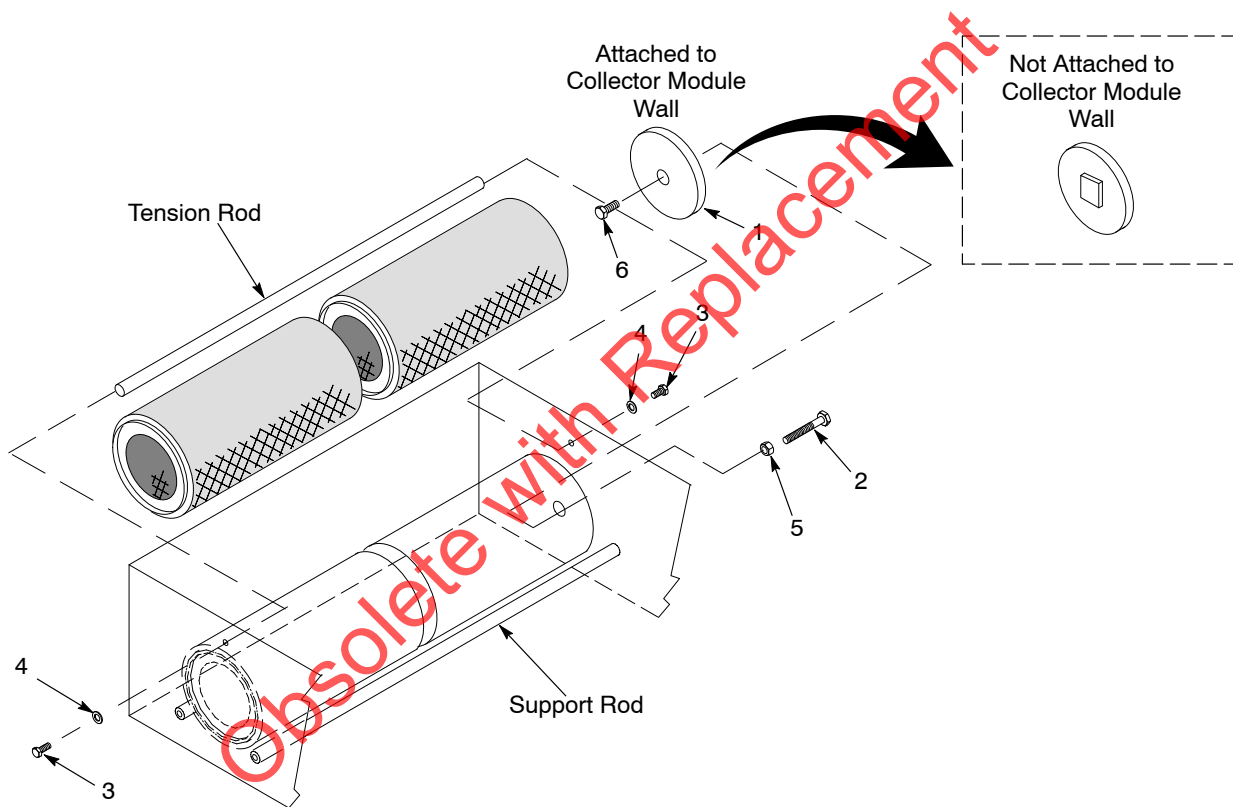

1401131B

Figure 1 Horizontal Mount Cartridge Filters

Issued 2/04

Original copyright date 2003. Nordson, the Nordson logo, and PowderGrid are registered trademarks of Nordson Corporation. Lexel is a trademark of Sasho, Inc. Colorado Corporation