

# Kinetix<sup>®</sup> Electrostatic Spray Gun Manual Air Spray and KVLP

Customer Product Manual

Part 334597G03

Issued 8/08

**For parts and technical support, call the Industrial Coating  
Systems Customer Support Center at (800) 433-9319 or  
contact your local Nordson representative.**

This document is subject to change without notice.  
Check <http://emanuals.nordson.com> for the latest version.



NORDSON CORPORATION • AMHERST, OHIO • USA

OBSOLETE

---

**Contact Us**

Nordson Corporation welcomes requests for information, comments, and inquiries about its products. General information about Nordson can be found on the Internet using the following address:  
<http://www.nordson.com>.

Address all correspondence to:  
Nordson Corporation  
Attn: Customer Service  
555 Jackson Street  
Amherst, OH 44001

**Notice**

This is a Nordson Corporation publication which is protected by copyright. Original copyright date 2000. No part of this document may be photocopied, reproduced, or translated to another language without the prior written consent of Nordson Corporation. The information contained in this publication is subject to change without notice.

**Trademarks**

Kinetix, Nordson, and the Nordson logo are registered trademarks of Nordson Corporation.

Kalrez and Viton are registered trademarks of E.I. DuPont de Nemours and Company.

Loctite is a registered trademark of Henkel Loctite Corporation.

MagnaLube is a registered trademark of General Magnaplate Corporation.

Perlast is a trademark of Precision Polymer Engineering Limited.

# Table of Contents

<b>Safety</b> .....	<b>1-1</b>
Introduction .....	1-1
Qualified Personnel .....	1-1
Intended Use .....	1-1
Regulations and Approvals .....	1-1
Personal Safety .....	1-2
High-Pressure Fluids .....	1-3
Fire Safety .....	1-4
Halogenated Hydrocarbon Solvent Hazards .....	1-4
Action in the Event of a Malfunction .....	1-5
Disposal .....	1-5
Safety Label .....	1-5
<b>Description</b> .....	<b>2-1</b>
Introduction .....	2-1
KVL P Description .....	2-3
Air Spray Description .....	2-3
Features .....	2-3
Options .....	2-3
Coating Materials .....	2-4
Theory of Operation .....	2-4
Electrostatic Charge .....	2-4
Fluid Flow .....	2-4
Air Flow .....	2-6
<b>Installation</b> .....	<b>3-1</b>
Preparation .....	3-1
Typical Air Spray and KVL P System .....	3-2
Air and Fluid Hose Connections .....	3-3
Air Hose .....	3-3
Selecting Fluid Hose or Fluid Tubing .....	3-3
Hose Options .....	3-4
Fluid Hose Connection .....	3-6
Gun Cable .....	3-6
Securing the Hoses and Cables .....	3-7
Gun Cable .....	3-7
Air and Fluid Hoses .....	3-7
Fluid Tip and Air Cap Installation .....	3-7

<b>Operation</b> .....	<b>4-1</b>
Introduction .....	4-1
System Startup .....	4-2
Fluid Pressure and Flow Rate Adjustments .....	4-2
Spray Pattern and Atomization Adjustments .....	4-3
Fluid Tips and Air Caps .....	4-4
Shutdown .....	4-4
Short-Term .....	4-4
Long-Term .....	4-4
Multi-Component Coatings .....	4-5
KVLP Performance Testing .....	4-5
Checking Air Cap Performance .....	4-7
<b>Maintenance</b> .....	<b>5-1</b>
Introduction .....	5-1
Daily .....	5-1
Periodically .....	5-2
System Flushing .....	5-3
Spray Gun Cleaning .....	5-3
Routine Cleaning .....	5-3
Extensive Cleaning .....	5-4
Electrostatic System Checks .....	5-4
<b>Troubleshooting</b> .....	<b>6-1</b>
Introduction .....	6-1
Common Problems .....	6-2
Spray Pattern/Film Build Troubleshooting .....	6-4
Electrostatic Troubleshooting .....	6-6
Multiplier Continuity and Resistance Check .....	6-7
Gun Cable Continuity Check .....	6-8

OBSOLETE

<b>Repair</b> .....	<b>7-1</b>
Tools/Supplies Required .....	7-2
Air Cap and Fluid Tip Replacement .....	7-2
Trigger Lock Replacement .....	7-4
Air Inlet Fitting Replacement .....	7-5
Air Inlet Fitting Removal .....	7-5
Air Inlet Fitting Installation .....	7-5
Needle Replacement .....	7-7
Preparation .....	7-7
Needle Removal .....	7-7
Needle Installation .....	7-8
Packing Cartridge and Needle Replacement .....	7-9
Preparation .....	7-9
Spray Gun Disassembly .....	7-9
Packing Cartridge and Needle Removal .....	7-11
Packing Cartridge and Needle Installation .....	7-12
Spray Gun Assembly .....	7-13
Horn Air Adjust Valve Replacement .....	7-14
Valve Removal .....	7-14
Valve Installation .....	7-14
Air Valve Replacement .....	7-16
Air Valve Removal .....	7-16
Air Valve Installation .....	7-17
Multiplier Replacement .....	7-18
Multiplier Removal .....	7-18
New Multiplier Installation .....	7-20
Gun Cable Replacement .....	7-21
Cable Removal .....	7-21
Cable Installation .....	7-21
Isocorer Fluid Supply Hose Replacement .....	7-22
Fluid Tube Replacement .....	7-24
Service Illustrations and Notes .....	7-26
Air Spray and KVLP Spray Gun with 1/4-in. ID Fluid Hose ..	7-26
Air Spray and KVLP Spray Gun with 3/8-in. OD Fluid Tube ..	7-28
<b>Parts</b> .....	<b>8-1</b>
Introduction .....	8-1
Using the Illustrated Parts List .....	8-1
Spray Gun Parts .....	8-2
Air Spray and KVLP Spray Gun with 1/4-in. ID Fluid Hose ..	8-2
Air Spray and KVLP Spray Gun with 3/8-in. OD Fluid Tube ..	8-6
Recommended Kits .....	8-10
Perlast Fluid Seal .....	8-10
Air Seal .....	8-10
Air Valve .....	8-10
Packing Cartridge .....	8-10
Trigger Lock .....	8-11
Needle with Resistor .....	8-11
Optional Hotpaint Fluid Seal .....	8-11
Optional PTFE Packing Cartridge .....	8-11
Optional Hoses and Couplings .....	8-12
Recommended Spare Parts .....	8-13
KVLP Compliance Kit .....	8-14
Adhesives, Sealants, and Lubricants .....	8-15
Air Spray Conical Nozzles .....	8-15

<b>Specifications</b> .....	<b>9-1</b>
Dimensions .....	9-1
Weight .....	9-1
Operating Pressures .....	9-1
KVLP Air Hose Requirements .....	9-1
Air Spray Air Hose Requirements .....	9-2
Standard Fitting Sizes .....	9-2
Gun Electrostatics .....	9-2
Conductivity Range .....	9-2
Approvals .....	9-2

OBSOLETE

# Section 1

## Safety

### Introduction

Read and follow these safety instructions. Task- and equipment-specific warnings, cautions, and instructions are included in equipment documentation where appropriate.

Make sure all equipment documentation, including these instructions, is accessible to persons operating or servicing equipment.

### Qualified Personnel

Equipment owners are responsible for making sure that Nordson equipment is installed, operated, and serviced by qualified personnel. Qualified personnel are those employees or contractors who are trained to safely perform their assigned tasks. They are familiar with all relevant safety rules and regulations and are physically capable of performing their assigned tasks.

### Intended Use

Use of Nordson equipment in ways other than those described in the documentation supplied with the equipment may result in injury to persons or damage to property.

Some examples of unintended use of equipment include

- using incompatible materials
- making unauthorized modifications
- removing or bypassing safety guards or interlocks
- using incompatible or damaged parts
- using unapproved auxiliary equipment
- operating equipment in excess of maximum ratings

### Regulations and Approvals

Make sure all equipment is rated and approved for the environment in which it is used. Any approvals obtained for Nordson equipment will be voided if instructions for installation, operation, and service are not followed.

## Personal Safety

To prevent injury follow these instructions.

- Do not operate or service equipment unless you are qualified.
- Do not operate equipment unless safety guards, doors, or covers are intact and automatic interlocks are operating properly. Do not bypass or disarm any safety devices.
- Keep clear of moving equipment. Before adjusting or servicing moving equipment, shut off the power supply and wait until the equipment comes to a complete stop. Lock out power and secure the equipment to prevent unexpected movement.
- Relieve (bleed off) hydraulic and pneumatic pressure before adjusting or servicing pressurized systems or components. Disconnect, lock out, and tag switches before servicing electrical equipment.
- While operating manual spray guns, make sure you are grounded. Wear electrically conductive gloves or a grounding strap connected to the gun handle or other true earth ground. Do not wear or carry metallic objects such as jewelry or tools.
- If you receive even a slight electrical shock, shut down all electrical or electrostatic equipment immediately. Do not restart the equipment until the problem has been identified and corrected.
- Obtain and read Material Safety Data Sheets (MSDS) for all materials used. Follow the manufacturer's instructions for safe handling and use of materials, and use recommended personal protection devices.
- Make sure the spray area is adequately ventilated.
- To prevent injury, be aware of less-obvious dangers in the workplace that often cannot be completely eliminated, such as hot surfaces, sharp edges, energized electrical circuits, and moving parts that cannot be enclosed or otherwise guarded for practical reasons.



## High-Pressure Fluids

High-pressure fluids, unless they are safely contained, are extremely hazardous. Always relieve fluid pressure before adjusting or servicing high pressure equipment. A jet of high-pressure fluid can cut like a knife and cause serious bodily injury, amputation, or death. Fluids penetrating the skin can also cause toxic poisoning.

If you suffer a fluid injection injury, seek medical care immediately. If possible, provide a copy of the MSDS for the injected fluid to the health care provider.

The National Spray Equipment Manufacturers Association has created a wallet card that you should carry when you are operating high-pressure spray equipment. These cards are supplied with your equipment. The following is the text of this card:



**WARNING:** Any injury caused by high pressure liquid can be serious. If you are injured or even suspect an injury:

- Go to an emergency room immediately.
- Tell the doctor that you suspect an injection injury.
- Show him this card
- Tell him what kind of material you were spraying

### MEDICAL ALERT—AIRLESS SPRAY WOUNDS: NOTE TO PHYSICIAN

Injection in the skin is a serious traumatic injury. It is important to treat the injury surgically as soon as possible. Do not delay treatment to research toxicity. Toxicity is a concern with some exotic coatings injected directly into the bloodstream.

Consultation with a plastic surgeon or a reconstructive hand surgeon may be advisable.

The seriousness of the wound depends on where the injury is on the body, whether the substance hit something on its way in and deflected causing more damage, and many other variables including skin microflora residing in the paint or gun which are blasted into the wound. If the injected paint contains acrylic latex and titanium dioxide that damage the tissue's resistance to infection, bacterial growth will flourish. The treatment that doctors recommend for an injection injury to the hand includes immediate decompression of the closed vascular compartments of the hand to release the underlying tissue distended by the injected paint, judicious wound debridement, and immediate antibiotic treatment.

## Fire Safety

To avoid a fire or explosion, follow these instructions.

- Ground all conductive equipment. Use only grounded air and fluid hoses. Check equipment and workpiece grounding devices regularly. Resistance to ground must not exceed one megohm.
- Shut down all equipment immediately if you notice static sparking or arcing. Do not restart the equipment until the cause has been identified and corrected.
- Do not smoke, weld, grind, or use open flames where flammable materials are being used or stored.
- Do not heat materials to temperatures above those recommended by the manufacturer. Make sure heat monitoring and limiting devices are working properly.
- Provide adequate ventilation to prevent dangerous concentrations of volatile particles or vapors. Refer to local codes or your material MSDS for guidance.
- Do not disconnect live electrical circuits when working with flammable materials. Shut off power at a disconnect switch first to prevent sparking.
- Know where emergency stop buttons, shutoff valves, and fire extinguishers are located. If a fire starts in a spray booth, immediately shut off the spray system and exhaust fans.
- Shut off electrostatic power and ground the charging system before adjusting, cleaning, or repairing electrostatic equipment.
- Clean, maintain, test, and repair equipment according to the instructions in your equipment documentation.
- Use only replacement parts that are designed for use with original equipment. Contact your Nordson representative for parts information and advice.

### ***Halogenated Hydrocarbon Solvent Hazards***

Do not use halogenated hydrocarbon solvents in a pressurized system that contains aluminum components. Under pressure, these solvents can react with aluminum and explode, causing injury, death, or property damage. Halogenated hydrocarbon solvents contain one or more of the following elements:

<u>Element</u>	<u>Symbol</u>	<u>Prefix</u>
Fluorine	F	“Fluoro-”
Chlorine	Cl	“Chloro-”
Bromine	Br	“Bromo-”
Iodine	I	“Iodo-”

Check your material MSDS or contact your material supplier for more information. If you must use halogenated hydrocarbon solvents, contact your Nordson representative for information about compatible Nordson components.

## Action in the Event of a Malfunction

If a system or any equipment in a system malfunctions, shut off the system immediately and perform the following steps:

- Disconnect and lock out system electrical power. Close hydraulic and pneumatic shutoff valves and relieve pressures.
- Identify the reason for the malfunction and correct it before restarting the system.





## Disposal

Dispose of equipment and materials used in operation and servicing according to local codes.

## Safety Label

Table 1-1 contains the text of the safety label on this equipment. The safety label is provided to help you operate and maintain your equipment safely. See Figure 2-1 for the location of the safety label.

Table 1-1 Safety Label

Symbol	Description
	<b>WARNING:</b> Allow only qualified personnel to use this equipment. Observe and follow all safety instructions for this equipment.
	<b>WARNING:</b> Risk of explosion or fire. Fire, open flames, and smoking prohibited.
	<b>WARNING:</b> Do not point the spray gun at any part of your body or at anyone else. Do not operate the fluid delivery system if any component is leaking. Failure to observe this warning could result in an injection injury.
	<b>WARNING:</b> Risk of electrical shock. Disconnect and lockout input power to equipment before servicing. Failure to observe this warning may result in personal injury or death.

OBSOLETE

## Section 2

# Description

## Introduction

See Figure 2-1.

The Kinetix air spray and KVLP manual electrostatic spray guns electrostatically charge and spray liquid coatings. The spray guns are powered by the Kinetix manual gun power supply and use an internal multiplier that is user-replaceable.

The spray gun is available with either a  $\frac{3}{8}$ -in. OD fluid tube or with a  $\frac{1}{4}$ -in. ID fluid hose.

The spray gun is non-circulating and can be used with heated and unheated non-circulating spray systems.

For systems that require circulation, a circulation fitting can be added to the base of the spray guns with the  $\frac{3}{8}$ -in. OD fluid tube only. Refer to the *Parts* section for ordering information.

KVLP and air spray systems use low-pressure fluid sources, such as pressure pots, diaphragm pumps, or low-ratio piston pumps. They are commonly used to apply low to medium viscosity fluids to products requiring a high-quality finish.

**NOTE:** The fluid tip and air cap you choose will determine if you will be using air spray technology or KVLP technology.

# Introduction *(contd)*

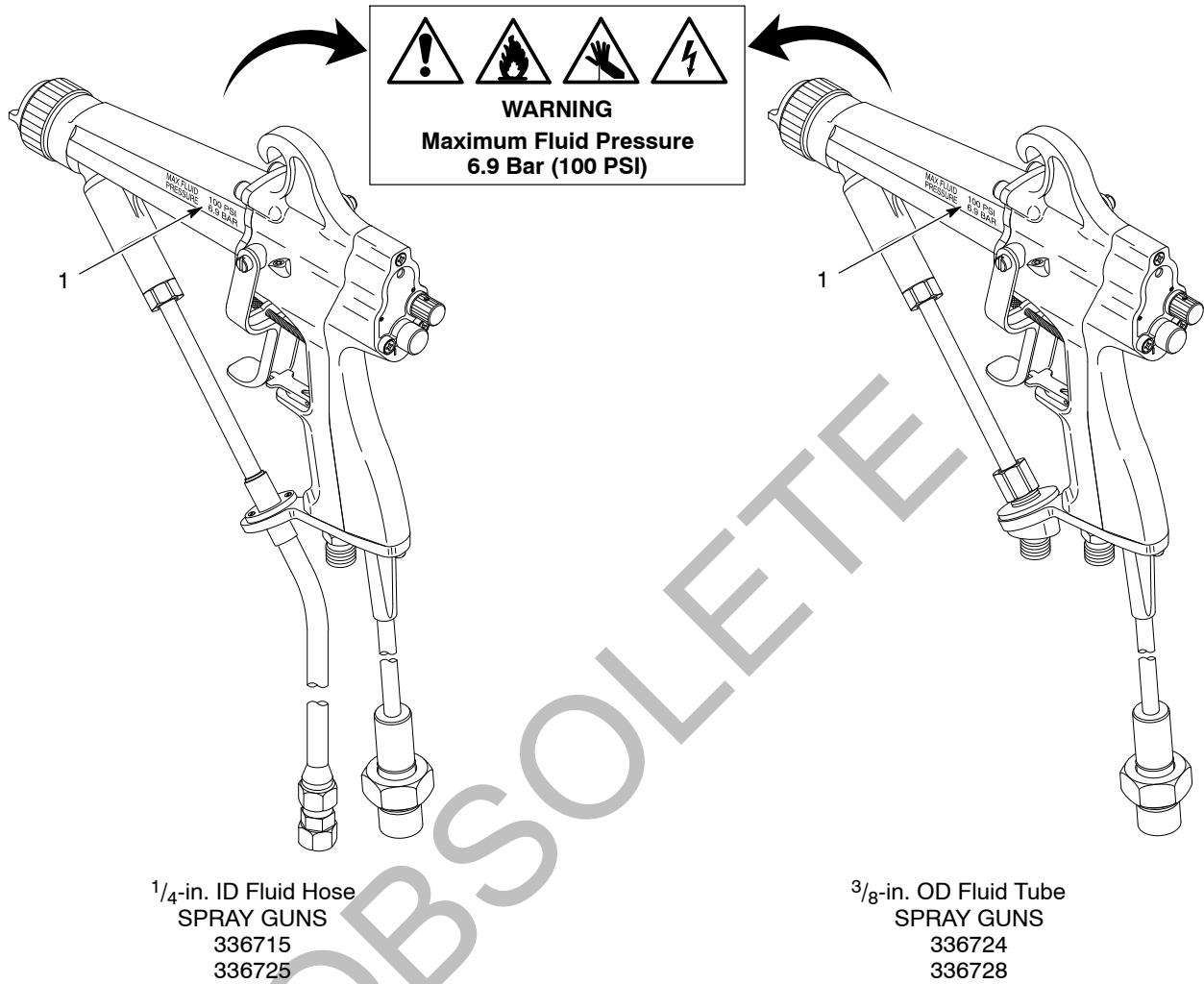

Figure 2-1 Kinetix Air Spray and KVLV Manual Electrostatic Spray Gun

*Note:* Refer to *Safety Labels* on page 1-5 for a description of the warning labels on the spray gun extension.

## KVLP Description

KVLP technology creates a soft spray with high transfer efficiency, reducing emissions of volatile organic compounds (VOCs). KVLP spray guns use high volumes of very low pattern control (horn) and atomizing air pressures (less than 0.69 bar (10 psi)). The high volume of pattern control air provides sufficient energy to atomize sprayed fluids. The low atomizing air pressure reduces fluid bounceback and overspray, which improves transfer efficiency.

KVLP atomization is typically coarser than air spray when used with high-viscosity fluids and high flow rates.

## Air Spray Description

Air spray technology atomizes material at higher air pressures and lower air flows than KVLP spray guns. Air spray guns produce a very fine, atomized mist. This makes them useful for extremely fine finishing work.

## Features

- adjustable horn air pressure and fluid flow rate
- large air passages for higher air energy
- easy disassembly for cleaning and repair
- self-adjusting packing cartridge

## Options

Options include a variety of fluid tips; air caps; air and fluid hoses; air pressure regulators; gauges; fittings; quick disconnect fluid hose; and quick exhaust. KVLP compliance kits are available for each KVLP air cap.

**NOTE:** The fluid tip and air cap you choose will determine if you will be using air spray technology or KVLP technology.

## Coating Materials

The spray gun is compatible with a wide variety of coating materials including

- general solvent-based
- metallics
- high-solids
- multi-component
- ultra-violet coating

**NOTE:** The seals installed in the spray gun are compatible with most coatings. If the coating material you use damages the seals, contact your Nordson Corporation representative for compatible replacements.

## Theory of Operation

See Figure 2-2.

### *Electrostatic Charge*

The gun control unit delivers low-voltage dc power through a cable (8) to the multiplier (3), which is housed in the extension (4) of the spray gun. The multiplier then generates high-voltage for an electrostatic field. This electrostatic field produces a corona discharge around the gun electrode (1). The LED voltage indicator (5) lights when the electrostatics are turned on.

The kV actuator switch (6) can turn the electrostatic power off at the gun to reduce the Faraday cage effects.

Resistors within the multiplier limit the output current at safe levels. High-voltage (93 kV) current passes through the gun electrode to electrostatically charge the coating material. As the charged coating material is sprayed, it is attracted to the grounded object to be coated.

### *Fluid Flow*

Fluid enters the spray gun through a fluid supply hose (10) attached to the extension and flows to the fluid tip (2). The fluid control knob (13) controls the trigger (12) travel, which in turn, controls the needle (15) travel.

The needle controls fluid flow through the fluid tip. The packing cartridge (14) prevents fluid from flowing past it into the handle. The fluid flow is dead-ended at the spray gun when the operation has stopped.



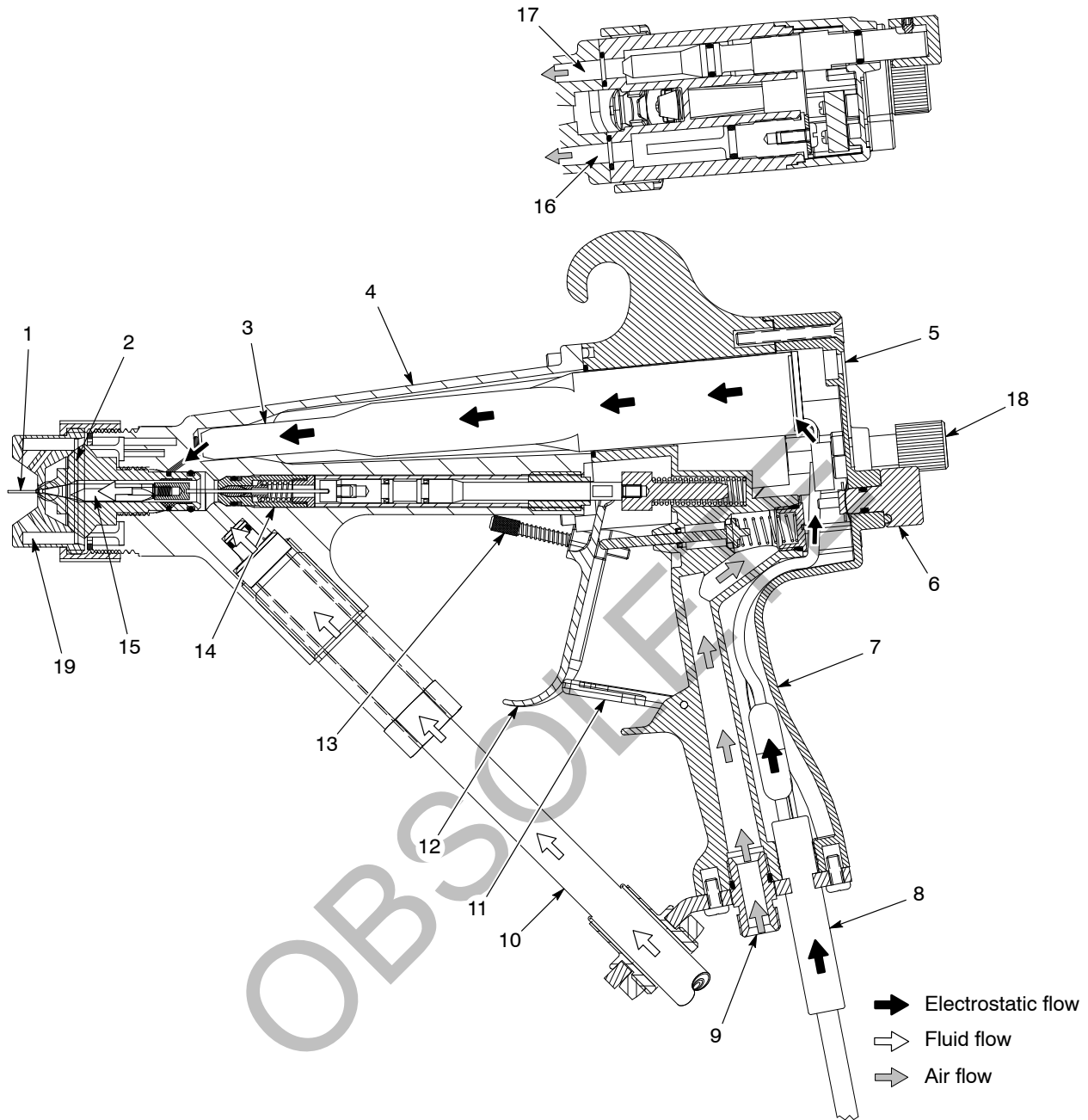

Figure 2-2 Spray Gun Components and Operation

- |                          |                                   |                                |
|--------------------------|-----------------------------------|--------------------------------|
| 1. Electrode             | 7. Handle                         | 13. Fluid control knob         |
| 2. Fluid tip             | 8. Gun cable                      | 14. Packing cartridge          |
| 3. Multiplier            | 9. Atomization and horn air inlet | 15. Needle                     |
| 4. Extension             | 10. Fluid supply hose             | 16. Atomization air core       |
| 5. LED voltage indicator | 11. Trigger lock                  | 17. Horn air core              |
| 6. kV actuator switch    | 12. Trigger                       | 18. Horn air adjust valve knob |
|                          |                                   | 19. Air cap                    |

## ***Air Flow***

The atomization and horn air enter through an inlet (9) in the spray gun handle (7).

Pulling the trigger opens the air valve and develops full atomization air flow. This air triggers an airflow switch in the multiplier, which turns on the electrostatic power.

The atomization air continues through the gun through its air core (16) when the spray gun is triggered. The atomization air atomizes the coating material as it exits the nozzle. To control the level of atomization, adjust the air flow regulator that supplies the gun.

The horn air (17) flows to the air cap (19) and shapes the spray pattern. This air flow is controlled by a valve in the gun handle.

The gun includes a trigger lock (11) to prevent accidental triggering of the spray gun and possible injection injuries.

OBSOLETE

## Section 3

# Installation



**WARNING:** Allow only qualified personnel to perform the following tasks. Follow the safety instructions in this document and all other related documentation.

## Preparation



**CAUTION:** Do not overtighten parts. Failure to observe this caution will result in equipment damage.

**NOTE:** Fluid tips, air caps, and hoses are not shipped with the spray gun. You must order them separately, based on your application. If you order a KVLP air cap, order the appropriate compliance kit also. You will need one compliance kit for each air cap size you use.

**NOTE:** Compliance caps are used to verify compliance of non-electrostatic KVLP systems. Electrostatic guns are by themselves compliant spray technologies so it is not necessary to verify air cap compliance. Instead, you may want to use a compliance kit to make sure the air cap pressure is at optimum level.

Before installation,

- make sure you have the appropriate fluid tip and air cap for your application.
- make sure you have air and fluid hoses of the correct length, ID, and materials.



**WARNING:** Risk of fire and/or electrical shock if the spray gun and system components are not properly grounded.

- make sure the system is properly grounded.

**NOTE:** Inadequately grounded parts will lose electrostatic attraction when sprayed.

- remove the spray gun, brushes, and combination tool from the box.



## Air and Fluid Hose Connections

Spray gun fittings accept standard Nordson fluid hoses.

### Air Hose

The air hoses supplying air to the spray gun should be a grounding type hose. Limit the number of restrictions in the air supply lines and hose to provide maximum air flow.

For optimum KVLV performance,  $\frac{3}{8}$ -in. ID hose is recommended with the hose no longer than 9.14 m (30 ft).

1. Clean the air hose fittings with a clean, dry cloth.
2. Connect the atomization air hose between the  $\frac{1}{4}$ -in. NPSM fitting in the spray gun handle and the air supply outlet.

### Selecting Fluid Hose or Fluid Tubing



**WARNING:** The fluid hose must be a grounding-type hose, with continuity between fittings. Without a ground, a static charge could build up in the spray gun, resulting in shocks to the operator or sparking that could cause a fire. Resistance checks, from hose fitting to hose fitting, should be a part of your regular maintenance procedures.

Refer to *Hoses and Couplings* on page 8-12 for hose or tube ordering information.

Current draw is an important consideration when selecting the fluid hose or fluid tube. The longer the hose/tube, the lower the current draw. The hose or tube ID also affects the current draw. The smaller the hose/tube ID, the lower the current draw. The pressure drop through the hose/tube increases with length and increases as hose/tube ID gets smaller. There is a tradeoff between effective fluid isolation to reduce current draw and minimizing pressure drop to maintain adequate fluid flow rates.

Current draw levels through the fluid hose or fluid tube of 20  $\mu$ A or less should provide adequate charging of the coating material. Higher current draws may be acceptable if transfer efficiency levels and wrap are acceptable.

Figure 3-3 identifies the required length of hose or tubing to maintain a current draw at 20  $\mu$ A for various coating resistivities. Refer to Table 3-2 for examples of the required length or hose for three selected resistivities.

Table 3-2 Hose/Tube Lengths for a 20  $\mu$ A Current Draw

Resistivity of Coating	Isocore Hose ( $\frac{1}{4}$ -in. ID)	Tubing ( $\frac{3}{8}$ -in. OD x 0.093-in ID)	Isocoil Assembly (0.093-in. coiled fluid tube)
0.025 M $\Omega$	21 ft	3.5 ft	
0.05 M $\Omega$	16.5 ft	2.5 ft	2 ft *
0.1 M $\Omega$	3.5 ft	1 ft	
0.25 M $\Omega$	1.5 ft	1 ft	

\* Two feet of 0.093-in. coiled fluid tube maintains a 20  $\mu$ A current draw for a 0.55 M $\Omega$  coating.

### Hose Options

**1/4-in. ID Fluid Hose Spray Gun:** This spray gun is provided with a standard 8-ft Isocore hose that has a 1/4-in. ID. This hose is flexible, minimizes pressure drop, and provides effective current isolation for most coating materials. An optional 25-ft version of this hose is also available.

**3/8-in. OD Fluid Tube Spray Gun:** This spray gun uses a short length of 3/8-in. OD x 0.093-in. ID fluid tubing that provides effective current isolation for most coatings.

**Isocoil Assembly:** 24 inches of 0.93-in. coiled fluid tube is included with the assembly.

See Figure 3-2, which identifies the best resistivity range for air spray coating.

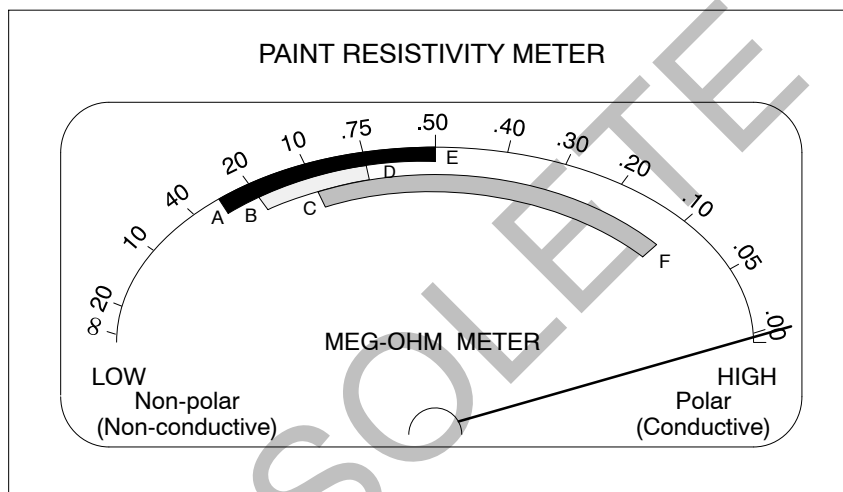

Legend:

- Best range for airspray electrostatic 0.5–3.0 range — A to E scale.
- Best range for airless and air-assisted airless electrostatic 0.75–2.0 range — B to D scale.
- Best range for rotary 0.10–1.0 range — C to F scale.

**NOTE:** Readings outside these ranges are often acceptable.

Figure 3-2 Resistivity Range for Coatings

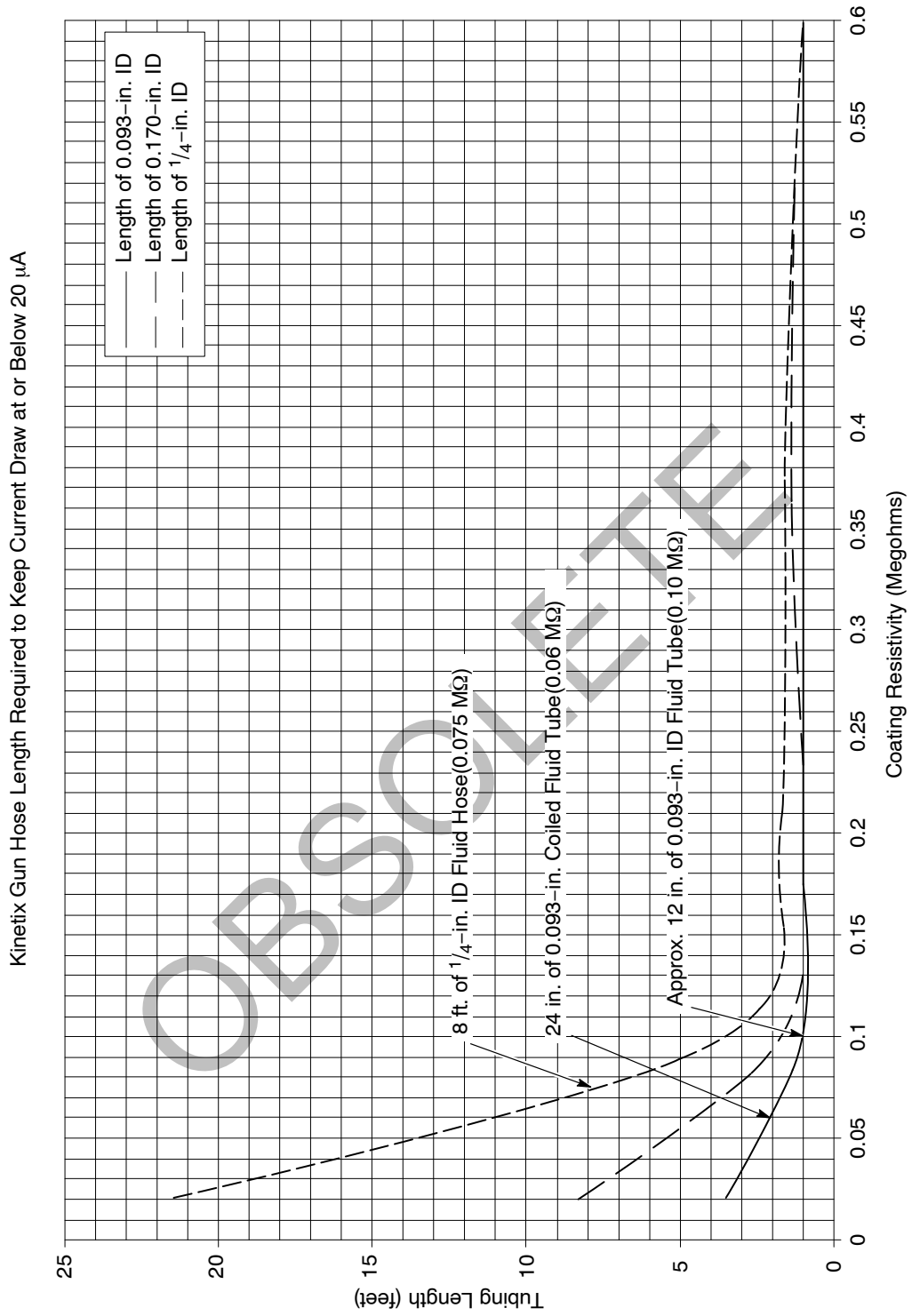

Figure 3-3 Hose Length Required to Keep Current Draw at or Below 20  $\mu$ A

## Fluid Hose Connection

1. Clean the fluid hose or fluid tube fittings with a clean, dry cloth.
2. Connect the fluid hose(s) or fluid tube between the fluid-delivery system outlet and the fluid line on the spray gun extension.

## Gun Cable



**WARNING:** Ground all electrically conductive equipment. Ungrounded conductive equipment can store a static charge, which could ignite a fire or cause an explosion if a hot spark is discharged. Wear shoes with conductive soles such as leather, or use grounding straps to maintain a connection to ground when working with or around electrostatic equipment.

**NOTE:** Refer to the gun control unit manual for more information.

See Figure 3-4. Connect the large round cable end (3) of the gun cable (4) to the POWER OUTPUT receptacle (2) on the back of the control unit (1).

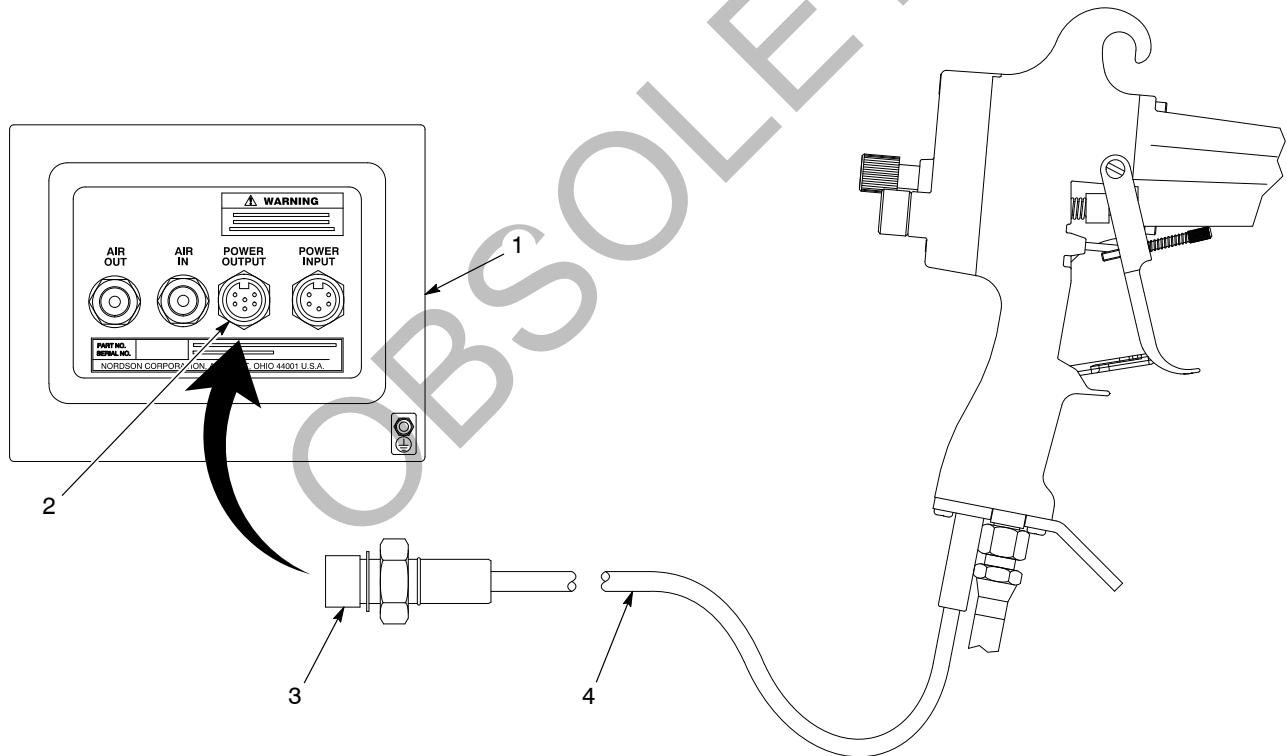

Figure 3-4 Electrostatic Cable Installation

- |                            |                          |              |
|----------------------------|--------------------------|--------------|
| 1. Control unit            | 3. Large round cable end | 4. Gun cable |
| 2. POWER OUTPUT receptacle |                          |              |



## Securing the Hoses and Cables

### Gun Cable

- Protect the ends of the gun cable so that no contaminants, oils, particles, or solvents are carried by it into the Kinetix manual gun power supply.
- Do not tie the cable to the machine members in areas where the cable must move or stretch.
- Do not bend the cable around a radius of less than 15.24 cm (6 in.) at stationary points and 20.3 cm (8 in.) at flexing points.
- Do not allow the cable to become abraded around sharp corners such as booth edges.
- Do not walk on the cable or run over it with heavy objects.
- Do not use cable ties. Use hook and loop tape to secure the cable.
- Bundle the gun cable with the air and fluid hoses.

### Air and Fluid Hoses

- Bundle the air and fluid hose(s) together with hook and loop tape, spiral-cut tubing, or similar devices. If you secure the hoses to a stationary object at any point between the fluid-delivery system, make sure the hoses can flex without strain.
- If desired, cover the spray gun body, hoses, and other equipment in the spray area with a grounded, conductive wrapping to keep them clean.

## Fluid Tip and Air Cap Installation



**WARNING:** Shut off the gun control unit and ground the spray gun electrode to remove any residual charge. Failure to observe this warning could result in personal injury.



**WARNING:** Shut off the fluid-delivery system, relieve the fluid pressure in the system, and make sure the trigger lock is engaged. Failure to observe this warning could result in an injection injury.

See Figure 3-5.

1. Turn off the gun control unit and ground the spray gun electrode (7) to remove any residual charge.
2. Point the spray gun into the booth or waste container and trigger the spray gun to relieve residual pressure. Engage the trigger lock to prevent inadvertent activation of the spray gun.
3. Unscrew the retaining ring (6). Remove the retaining ring and air cap (5) assembly.
4. Prepare the fluid tip (4) by installing the O-ring (2) in the groove on the fluid tip. Lubricate the O-ring with dielectric grease.

## Fluid Tip and Air Cap Installation *(contd)*

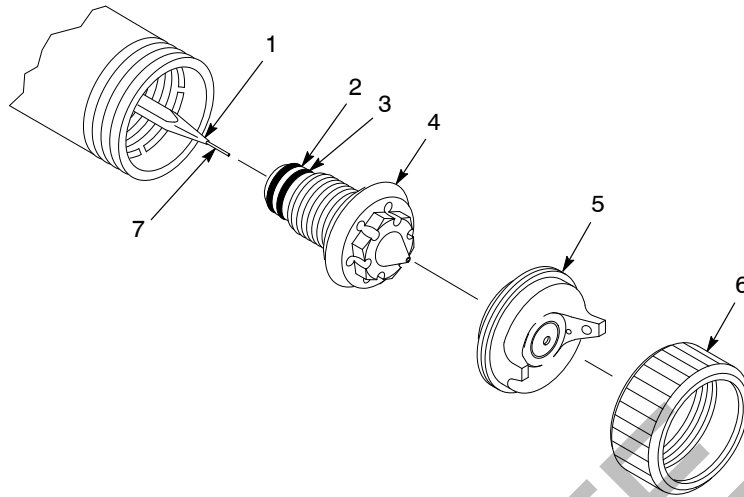

Figure 3-5 Fluid Tip and Air Cap Installation

- |                            |              |                   |
|----------------------------|--------------|-------------------|
| 1. Needle                  | 4. Fluid tip | 6. Retaining ring |
| 2. O-ring                  | 5. Air cap   | 7. Electrode      |
| 3. Conductive back-up ring |              |                   |

5. Make sure the conductive back-up ring (3) is installed on the fluid tip.



**CAUTION:** To prevent damage to the needle and fluid tip seat, trigger the spray gun to pull the needle tip back before removing or installing a fluid tip.

6. Pull the trigger to retract the needle (1). Screw the fluid tip into the threaded bore of the spray gun.



**CAUTION:** The spray gun fluid seal is an O-ring. The O-ring sealing capability is provided by radial squeeze. Tightening the fluid tip beyond snug does not prevent or eliminate fluid leaks.

7. Tighten the fluid tip with the internal hex of the combination tool until it is snug. Do not overtighten the fluid tip.

8. Make sure the air cap rests in the groove in the bottom of the retaining ring and that it rotates freely.

**NOTE:** You may want to remove the air cap, install the appropriate KVLP compliance kit, and test for optimum performance. Refer to *KVLP Performance Testing* on page 4-5.

9. Screw the retaining ring and air cap assembly onto the extension. Hold the air cap in the desired position and tighten the retaining ring until it is snug.

**NOTE:** The air cap screws into the retaining ring and rests in a groove in the ring that lets it rotate freely. Do not overtighten the air cap.

## Section 4

# Operation



**WARNING:** Allow only qualified personnel to perform the following tasks. Follow the safety instructions in this document and all other related documentation.

## Introduction



**WARNING:** This equipment can be dangerous unless it is used in accordance with the rules laid down in this manual.



**WARNING:** Do not exceed the maximum fluid pressure rating of 6.9 bar (100 psi). Failure to follow this warning may result in death or personal injury.



**WARNING:** The spray gun includes a trigger lock. Engage the trigger lock to prevent accidental triggering of the spray gun and possible injection injuries. Failure to observe this warning may result in injury.

**NOTE:** Read this entire section before performing any procedures.

Before operating the spray gun, make sure that

- the fluid tip is securely tightened and the air cap is correctly installed and secured with the retaining ring.
- all fluid and air connections are secure and leak-free. The fluid hose is grounded.
- air supply and fluid-delivery components are correctly installed. All conductive system components and flammable material containers are securely connected to a true earth ground.
- the operator's station and spray area are clean and free of debris.

## System Startup



**WARNING:** Never operate the spray gun with a worn or damaged trigger lock. Failure to observe this warning may result in injury.

**NOTE:** When starting a new spray system for the first time, flush the fluid-delivery system, hose, and spray gun with a solvent compatible with the coating material to be used. Remove the air cap from the spray gun before flushing solvent through the spray gun. Flushing will remove contaminants from the system.

1. Turn on the spray booth exhaust fans then turn on the air supply shutoff valve. Adjust the air pressure as required for your application. Do not exceed 6.9 bar (100 psi).
2. Pressurize the system with fluid. Do not exceed 6.9 bar (100 psi).
3. Turn on the fluid heater(s), if used. Do not exceed 82 °C (180 °F).
4. Check the fluid-delivery system for leaks.
5. Adjust the fluid and air pressures to achieve optimum atomization and desired pattern width. Refer to *Spray Pattern and Atomization Adjustments* on page 4-3.
6. Lock the gun trigger and turn on the gun control unit.
7. Unlock the trigger and trigger the spray gun to verify that electrostatics are on.

**NOTE:** Triggering the spray gun should produce atomized spray and start the multiplier. The red indicator should illuminate on the back cover of the spray gun. Adjust the fluid pressure to obtain the desired atomization and spray pattern. Refer to *Spray Pattern and Atomization Adjustments* on page 4-3.

**NOTE:** If kV is erratic, check that the control unit is on. If the kV voltage indicator is flickering or is off, increase the air pressure.

8. Use a Nordson kV meter to read the maximum kV output of the power supply. Use this information and the values from *Electrostatic Troubleshooting* on page 6-6 as a baseline when troubleshooting the electrostatic system.

## Fluid Pressure and Flow Rate Adjustments

Shut off the air supply to the spray gun and check the fluid flow rate.

For optimum atomization, an appropriate fluid supply pressure should develop an unatomized fluid stream that breaks at a distance of 25.4–35.6 cm (10–14 in.). If the flow rate does not have an acceptable fluid stream, increase the fluid tip diameter and adjust the fluid pressure until a break of 25.4–35.6 cm (10–14 in.) is achieved at your required flow rate.

If the flow rate is too high, turn the fluid control knob clockwise in small increments. This will decrease needle travel and fluid flow. For more significant flow rate changes, adjust the fluid supply pressure or use the next smallest or largest fluid tip.

For best results, leave the fluid control knob adjusted fully open. If you have to limit the stroke to less than half the needle travel, you are using too large a fluid tip.

**NOTE:** Make sure that the atomizing and horn air pressures are 0.69 bar (10 psi) or less. KVLP spray guns will provide optimum transfer efficiency when air pressures are limited to less than 0.69 bar (10 psi) but it is not required.

## Spray Pattern and Atomization Adjustments

Obtaining the correct spray pattern, coating material atomization, and transfer efficiency for your application requires a combination of operator experience and experimentation. To obtain the best results, perform the following steps:



**WARNING:** Shut off the gun control unit and ground the spray gun electrode to remove any residual charge. Failure to observe this warning could result in personal injury.

1. Set the supply air pressures to the spray gun. Use the lowest possible air pressure to obtain proper atomization of the coating material. Increasing the air pressure provides finer atomization. Decreasing the air pressure provides coarser atomization. If using a KVLP spray gun, refer to *KVLP Performance Testing* on page 4-5 for suggested starting air pressures.
2. Point the spray gun into the booth and trigger the spray gun.
3. Adjust the horn air supply pressure to achieve the desired spray pattern. Higher pressures will generate a wider fan pattern. Lowering the pressure will decrease the pattern width and create a rounder pattern.
4. Repeat steps 1, 2, and 3 until you achieve the desired spray pattern and atomization. If necessary, adjust the fluid and air pressure at the fluid and air delivery systems. Use the lowest atomizing air pressure possible along with the appropriate fluid flow rates to ensure maximum transfer rates and highest quality finishes.
5. **If you are using a KVLP air cap and fluid tip:** Test for optimum KVLP performance. Both atomizing and horn air pressures should be 0.69 bar (10 psi) or less. Refer to *KVLP Performance Testing* on page 4-5.

## Fluid Tips and Air Caps



**WARNING:** Shut off the power supply. Ground the spray gun's electrode to remove any residual charge. Failure to observe this warning could result in personal injury.

Different combinations of fluid tips and air caps can improve atomization and spray patterns with various coating materials and viscosities. If the fluid flow and air adjustments described previously do not produce the desired results, try a different combination of fluid tip and air cap.

A full range of airspray and KVLP fluid tips and air caps are available that can improve coating quality. Refer to the *Kinetix KVLP and Air Spray Fluid Tip and Aircap Selection Charts* included with this manual for part numbers. Refer to *KVLP Performance Testing* on page 4-5 for information on optimum KVLP performance.

## Shutdown



**WARNING:** Shut off the power supply. Failure to observe this warning could result in personal injury.



**WARNING:** Shut off the fluid-delivery system and relieve the fluid pressure in the system before removing any spray gun components. Failure to observe this warning could result in personal injury.

## Short-Term

For short-term breaks in production, no shutdown procedures are necessary. Release and lock the trigger and wipe the cap and fluid tip with a clean cloth dampened with a compatible solvent.

## Long-Term



**WARNING:** Shut off the fluid-delivery system and relieve the system pressure before removing any spray gun components. Failure to observe this warning could result in personal injury.

1. Shut off the power supply.
2. Shut off the atomization and horn air.
3. Flush the fluid-delivery system, fluid hose(s), and spray gun with a compatible solvent.

**NOTE:** Refer to the *Flush the System* on page 5-3 for recommended flushing and cleaning procedures.

4. Relieve system fluid pressure.

5. Trigger the spray gun into a waste container to relieve fluid and air pressures.
6. Remove the air cap and fluid tip.

## Multi-Component Coatings



**CAUTION:** Leaving the coating material in the spray gun longer than the indicated pot-life may clog the spray gun and require disassembly and replacement of major spray gun components.

Refer to the coating material pot-life information to determine the proper shutdown procedures.

## KVLP Performance Testing

To maintain optimum KVLP performance, both atomizing and horn air pressures should be 0.69 bar (10 psi) or less. Each KVLP air cap has a corresponding KVLP compliance kit that consists of a modified air cap, air tubing, and pressure gauges. Kits must be ordered separately for each type of air cap. Refer to the *Kinetix KVLP and Air Spray Fluid Tip and Aircap Selection Charts* included with this manual for part numbers.

**NOTE:** The 0.69 bar (10 psi) limit is for reference only and is not required. Many coating materials can be atomized using less pressure. Lower pressures will result in a softer pattern which will lead to better transfer efficiency, assuming that there is enough air to adequately atomize the coating material.

Table 4-1 provides air pressure settings you can use as an approximate starting point when setting up your spray gun. The table shows the approximate static regulator setting (psig) and resulting airflow (scfm) at an atomizing air cap pressure of 0.69 bar (10 psig). This data was generated using 25-ft of  $\frac{3}{8}$ -in. OD wall tubing. Note that any restrictions in the line after the regulator, such as 90-degree fittings, quick disconnects, or valves, will affect the pressures at the air cap.

The air pressure settings in Table 4-1 do not guarantee optimum KVLP performance. After making an air pressure setting, perform a KVLP compliance test. See Figure 4-1 and refer to *Checking Air Cap Performance* on page 4-7 for kit installation.

Table 4-1 Air Pressure Settings – Wall Mounted Regulator with 7.62-m (25-ft), 9.5-mm (<sup>3</sup>/<sub>8</sub>-in.) ID Air Hose

Fluid Tip Orifice	Approximate Static Regulator Pressure Setting (psig) and Approximate Air Flow (scfm) at Maximum Compliance Condition									
	Air Cap									
	325714		325715		325716		325717		325719	
	psig	scfm	psig	scfm	psig	scfm	psig	scfm	psig	scfm
0.030	23	11	25	12	27	13	30	15	37	18
0.035	22	11	25	12	27	14	30	15	37	19
0.040	23	11	24	12	26	14	30	15	36	19
0.050	20	10	22	11	24	12	26	13	32	17
0.060	X	X	20	10	22	11	24	12	30	15
0.070	X	X	X	X	21	10	23	11	29	15
0.080	X	X	X	X	X	X	23	11	29	14
0.100	X	X	X	X	X	X	X	X	24	12
Fluid Tip Orifice	Approximate Static Regulator Pressure Setting (psig) and Approximate Air Flow (scfm) at Maximum Compliance Condition									
	Air Cap									
	325721		325723		325725		325727			
	psig	scfm	psig	scfm	psig	scfm	psig	scfm		
0.030	46	23	57	28	65	32	69	34		
0.035	46	23	57	28	66	33	70	34		
0.040	45	22	56	28	66	33	67	33		
0.050	40	20	49	25	59	29	68	33		
0.060	38	19	49	25	60	30	66	32		
0.070	36	18	45	23	56	28	65	32		
0.080	36	18	46	23	58	28	66	32		
0.100	30	15	38	20	48	24	62	31		
<b>NOTE:</b> X represents a non-practical combination. Consult your Nordson Corporation representative if this combination is desired.										



## Checking Air Cap Performance



**WARNING:** Shut off the fluid-delivery system and relieve system fluid pressure before performing a compliance test. Failure to observe this warning could result in personal injury.

**NOTE:** This procedure is only necessary to achieve optimum air cap performance in order to achieve optimum transfer efficiencies. It is acceptable to exceed pressure limits. The lower the air pressure, the softer the spray.

See Figure 4-1.

1. Turn off the power supply and ground the gun's electrode to remove any residual charge.
2. Shut off the fluid-delivery system and relieve fluid pressure to prevent fluid from spraying while performing the compliance test.
3. Remove the production air cap and retaining ring and replace them with the air cap (4) and retaining ring (1) included with the KVLP compliance kit.
4. Trigger the spray gun to fully open the air valve.
5. Check the air pressure gauges (2, 3). Both atomization and horn pressures should be 0.69 bar (10 psi) or less.
6. If the atomization pressure exceeds 0.69 bar (10 psi), reduce the regulated air supply pressure and check the atomization quality.
7. If the horn air pressure exceeds 0.69 bar (10 psi),
  - turn the horn air valve clockwise to reduce the pressure. This will automatically increase the atomization air pressure.
  - or
  - reduce the supply pressure. This will automatically lower both the atomization and horn air pressures.
8. Install the production air cap and check the fluid atomization.

**NOTE:** You can check the atomization quality with the compliance cap installed. Simply make sure the tubing is not interfering with the spray pattern and is not crimped when held back.

9. If atomization quality is unacceptable, install the next size larger air cap or increase the air pressure above optimum level.

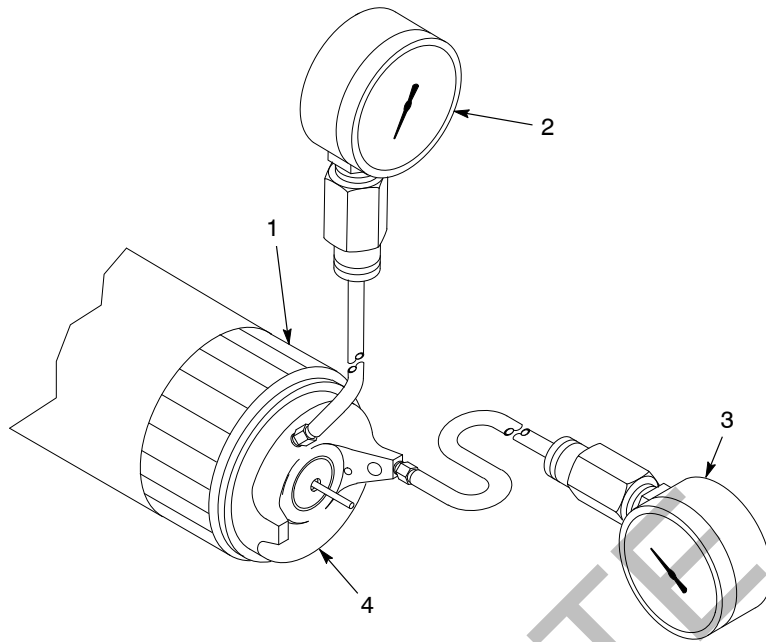

Figure 4-1 Checking Air Cap Performance

- 1. Retaining ring
- 2. Atomization air gauge
- 3. Horn air gauge
- 4. Compliance air cap

## Section 5

# Maintenance



**WARNING:** Allow only qualified personnel to perform the following tasks. Follow the safety instructions in this document and all other related documentation.

## Introduction

The spray gun requires very little routine maintenance beyond cleaning. For best results, keep the spray gun as clean as practical.

**NOTE:** Three spray gun covers are provided with each spray gun. Keeping the spray gun clean can minimize wrapback and improve transfer efficiency.

## Daily

Perform the following procedure at the end of each work shift:



**WARNING:** Shut off the power supply. Ground the spray gun's electrode to remove any residual charge. Failure to observe this warning could result in personal injury.



**WARNING:** Shut down the system and relieve all fluid and air pressures before performing these procedures. Failure to observe this warning could result in injury.

1. Turn off the gun control unit and ground the spray gun electrode to remove any residual charge.
2. Shut down the atomization and horn air pressures.
3. Flush the fluid delivery system, fluid hose, and spray gun with a compatible solvent.
4. Shut down the fluid-delivery system and relieve all fluid and air pressures.
5. Trigger the gun into the booth or grounded waste container to relieve any residual pressure. Lock the trigger.



**CAUTION:** To prevent damage to the needle and fluid tip seat, trigger the spray gun to pull the needle back before removing or installing a fluid tip.

6. Remove the fluid tip and air cap.

## Daily *(contd)*



**CAUTION:** Use a non-conductive solvent compatible with your coating material. Cleaning with conductive solvents can result in loss of kV, carbon tracking, and permanent damage to spray gun components.



**CAUTION:** Use only a Nordson cleaning brush to clean the fluid tip and air cap. Using metal tools will damage the fluid tip and air cap causing faulty spray patterns.



**CAUTION:** Avoid cleaning the spray gun with pressurized solvents. Spraying with pressurized solvents can force the solvent into spray gun cavities, potentially damaging spray gun components.

7. Remove the O-ring and back-up ring from the fluid tip. Soak the fluid tip and air cap in a suitable non-conductive solvent to dissolve any accumulated coatings, then use the brush included with the spray gun to clean them.
8. Clean the spray gun extension frequently with a clean cloth dampened with non-conductive solvent. Do not soak the spray gun in solvent.
9. Dry the fluid tip, air cap and spray gun with low-pressure air from an OSHA-approved blowgun.
10. Replace the O-ring and back-up ring on the fluid tip. Lubricate the O-ring with O-ring grease.

## Periodically

Periodically perform the following maintenance procedures on the spray gun. The frequency of these procedures will vary depending on the application and coating material being used.



**WARNING:** Shut off the power supply. Ground the spray gun's electrode to remove any residual charge. Failure to observe this warning could result in personal injury.



**WARNING:** Shut down the system and relieve all fluid and air pressures before performing these procedures. Failure to observe this warning could result in injury.



**CAUTION:** Use a non-conductive solvent compatible with your coating material. Cleaning with conductive solvents can result in carbon tracking and loss of kV.



**CAUTION:** Avoid cleaning the spray gun with pressurized solvents. Spraying with pressurized solvents can force the solvent into spray gun cavities, potentially damaging spray gun components.

## System Flushing

1. Relieve system fluid pressure and make sure the spray gun cannot be activated.
2. Turn off the gun control unit and ground the spray gun electrode to remove any residual charge.
3. Point the spray gun down into a grounded waste container. Trigger the spray gun to drain the spray gun and hose(s). Lock the trigger.
4. Remove the retaining ring and air cap.
5. Turn on the solvent supply and adjust it to the lowest possible pressure.
6. Unlock the trigger and trigger the gun into a suitably grounded container. Allow solvent to flow until it runs clear.
7. Turn off the solvent supply and relieve the pressure. Disconnect the fluid hose(s).

## Spray Gun Cleaning

**NOTE:** Trigger the spray gun to pull the needle out of the seat before removing the fluid tip. This will prevent damage to the needle and the seat.



**CAUTION:** Do not clean the multiplier or the electrostatic cables with solvent. Failure to observe this caution could result in equipment damage.

### Routine Cleaning

1. Remove the fluid tip.
2. Disconnect the air hose and fluid hose(s).



**CAUTION:** Use a non-conductive solvent compatible with your coating material. Cleaning with conductive solvents can result in carbon tracking and loss of kV.



**CAUTION:** Use only a Nordson cleaning brush to clean the fluid tip and air cap. Using metal tools will damage the fluid tip and air cap causing faulty spray patterns.

3. Point the spray gun down and clean the front of the spray gun with a soft-bristled brush dampened with a compatible cleaning solvent.

**NOTE:** Pointing the spray gun down at a slight angle will prevent solvents from entering the air passages and possibly damaging the air seals. Most air seals are not universally compatible with all solvents and can be damaged.

## Spray Gun Cleaning *(contd)*

4. Dampen a soft cloth with a compatible cleaning solvent. Point the spray gun downward and clean the exterior.

**NOTE:** Take special care when cleaning the spray gun's handle with solvents. Excessive amounts of solvent can leak into the spray gun and damage the multiplier. If the handle requires extensive cleaning, remove the multiplier. Refer to the *Multiplier Replacement* on page 7-19 for the procedure to remove the multiplier.

5. Clean the fluid tip, cap, and retaining ring with a soft-bristled brush and a compatible solvent. Remove the O-rings and back-up ring and soak the fluid tip in solvent if necessary.
6. Install the retaining ring, air cap, and fluid tip. Make sure the needle is retracted before installing the fluid tip.
7. Install the air hose and fluid hose(s).

### Extensive Cleaning



**CAUTION:** Never soak or vigorously clean the spray gun with the multiplier installed.

For more extensive cleaning, disassemble the spray gun and clean each part. Once disassembled, the extension and handle can be soaked in solvent and scrubbed. Remove all the seals before soaking any parts in solvent.

**NOTE:** Allow parts that have been soaked or heavily washed in solvent to dry thoroughly (overnight) before assembling and reusing the spray gun.

## Electrostatic System Checks

Use a Nordson non-loading kV meter to perform checks on the electrostatic system, and a megohmmeter to check the resistance values on the spray gun. These checks ensure that the operator, electrostatic spray gun, electrostatic power supply, and all conductive material within the spray area are connected to a true earth ground. Proper grounding is essential for efficient operation and prevention of a buildup and subsequent discharge of an electrostatic charge that could ignite combustible material within the spray area.

Make sure the electrostatic equipment has and maintains the proper resistance values. Proper resistance values are important to maintain the equipment within designed current outputs. The resistance values may vary over a period of time due to several conditions; for example, a buildup of residue in the spray area and degradation of electrical components that have been exposed to high voltages may occur.

## Section 6

# Troubleshooting



**WARNING:** Allow only qualified personnel to perform the following tasks. Follow the safety instructions in this document and all other related documentation.

## Introduction



**WARNING:** Shut off the gun control unit and ground the spray gun electrode to remove any residual charge. Failure to observe this warning could result in personal injury.

This section contains troubleshooting procedures. These procedures cover only the most common problems that you may encounter. If you cannot solve the problem with the information given here, contact your local Nordson representative for help.

This section contains troubleshooting procedures for

- common spray gun problems;
- spray pattern and film-build faults; and
- electrostatics.

When multiple causes exist for a problem, they are listed in order of importance.

## Common Problems

Problem	Possible Cause	Corrective Action
<b>1. Spray gun spitting</b>	Clogged or damaged needle or fluid tip	Clean or replace the needle and/or fluid tip.
	Partially plugged or dirty air cap	Clean the air cap.
	Air bubbles in fluid stream	Bleed air from the fluid-delivery system; check for leaks in the fluid-delivery system or excessive agitation in the fluid reservoir.
	Fluid pressure too low	Increase the fluid pressure.
<b>2. Air leaks</b>	Foreign matter on air valve or worn air valve	Remove and clean the air valve and its seals. Replace the air valve if it is worn or damaged.
	Worn or damaged air seal O-rings or other air seals	Replace the air seal O-rings or other seals.
<b>3. Fluid leaking from front of spray gun</b>	Worn or damaged fluid tip O-ring	Replace the fluid tip O-ring.
	Worn or damaged needle or seat	Replace the fluid tip if the seat is damaged. Replace the needle if it is damaged.
<b>4. Fluid leaking from rear of extension</b>	Worn or damaged packing cartridge O-ring	Replace the O-ring and backup ring.
	Worn or damaged packing cartridge	Replace the packing cartridge (packing cartridge cannot be repaired).
<b>5. Spray pattern not affected by air adjustments</b>	No air to spray gun	Supply air to the spray gun. Check for blockage in the air spray line. Adjust the supply air regulator.
	Atomization air pressure too high	Decrease the atomization air pressure.
	Plugged holes in air cap	Clean the air cap.
<b>6. Low or erratic fluid flow</b>	Fluid-delivery system malfunction	Check the fluid delivery system (air and fluid).
	Blockage within spray gun, fluid hose, or fluid system	Flush the system. If necessary, repair or replace clogged or damaged components.
	Low fluid pressure	<b>WARNING:</b> Do not exceed the maximum fluid pressure rating of 6.9 bar (100 psi). Slowly raise the fluid pressure until the desired fluid flow is obtained.
	Fluid too viscous	Lower the viscosity by adding solvent or increasing the fluid temperature.
	Damaged fluid tip or air cap	Inspect the fluid tip and air cap; replace them if they are damaged.

Continued...



<b>Problem</b>	<b>Possible Cause</b>	<b>Corrective Action</b>
<b>6. Low or erratic fluid flow</b> ( <i>contd</i> )	Fluid needle has backed out of packing cartridge fitting	Screw the needle into the packing cartridge fitting. If the problem persists, make sure the operators are pulling the trigger before removing the fluid tip. A removeable threadlocking compound can be applied to the threads of the needle to keep it in place.
<b>7. Coarse spray</b>	Air pressure too low for fluid flow rate	Decrease the fluid flow rate or increase air pressure. Change the air cap and fluid tip.
	Fluid viscosity too high for atomizing air pressure	Increase the atomizing air pressure, use a larger air cap, or reduce fluid viscosity by either adding solvent or increasing fluid temperature.
	Damaged fluid tip or air cap	Inspect the fluid tip and air cap; replace them if they are damaged.
	Obstructed atomizing air orifice	Clean the air cap and exterior surface of fluid tip.
<b>8. Excessive overspray</b>	Atomization air pressure too high	Decrease the atomization air pressure.
	Fluid pressure too high	Use a larger fluid tip and reduce the fluid pressure.
<b>9. Excessive bounce back</b>	Air and fluid pressures too high	Decrease the pressures.
	Horn air pressure too high	Decrease the horn air pressure.
<b>10. Dry spray</b>	Spray gun held too far away from substrate	Move the spray gun closer to the substrate.
	Horn air pressure too high or fluid pressure too low	Decrease the horn air pressure or increase fluid pressure. Change the air cap or fluid tip.
	Solvent evaporates too quickly	Use slower evaporating solvent. Contact your material supplier.
<b>11. Paint or coating material is wrapped back</b>	Spray gun needs to be cleaned	Clean the spray gun. Refer to <i>Clean the Spray Gun Components</i> on page 5-3. Use a gun cover.

## Spray Pattern/Film Build Troubleshooting

Figure 6-1 illustrates common spray pattern and film-build faults.

Problem	Possible Cause	Corrective Action
<b>1. Blown pattern (1)</b>	Horn air pressure too high	Decrease the horn air pressure.
	Fluid pressure too low	Increase the fluid pressure.
<b>2. Heavy top (3), bottom (2), left (4) or right (5) pattern</b>	Partially clogged air cap or fluid tip	Rotate the air cap and activate spray gun. If the problem persists, clean the air cap. If the problem still persists, clean the fluid tip or inspect the air cap and fluid tip for damage. Replace if necessary.
	Fluid viscosity incorrect	Change the fluid viscosity.
<b>3. Heavy center (6)</b>	Atomization or horn air pressure too low	Increase the atomization and horn air pressure.
	Fluid pressure too high	Decrease the fluid pressure.
	Fluid too viscous	Decrease the fluid viscosity.
<b>4. Spitting (7)</b>	Air in fluid line	Purge the air from the fluid-delivery system.
	Atomization or horn pressure too low	Increase the atomization air and fluid pressure and/or increase the horn air pressure.
	Fluid too viscous	Decrease the fluid viscosity.
<b>5. Runs and sags</b>	Air in fluid line	Purge the air from the fluid-delivery system.
	Atomization air pressure too low	Increase the atomization air pressure and decrease fluid pressure.
	Fluid pressure too high	Increase the atomization air pressure and decrease fluid pressure.
	Spray gun too close to substrate	Move the spray gun farther from the substrate.
	Horn air pressure too low	Increase the horn air pressure.
	Fluid too viscous	Decrease the fluid viscosity.

*Continued...*

Problem	Possible Cause	Corrective Action
<b>6. Dry spray</b>	Atomization air pressure too high	Decrease the atomization air pressure.
	Spray gun too far from the substrate	Move the spray gun closer to the substrate.
	Horn air pressure too low	Decrease the horn air pressure.
	Fluid viscosity incorrect	Change the fluid viscosity.
<b>7. Poor coverage in recesses</b>	Atomization air pressure too high	Decrease the atomization air pressure.
	Fluid pressure too high	Decrease the fluid pressure.
	Spray gun too far from the substrate	Move the spray gun closer to the substrate.

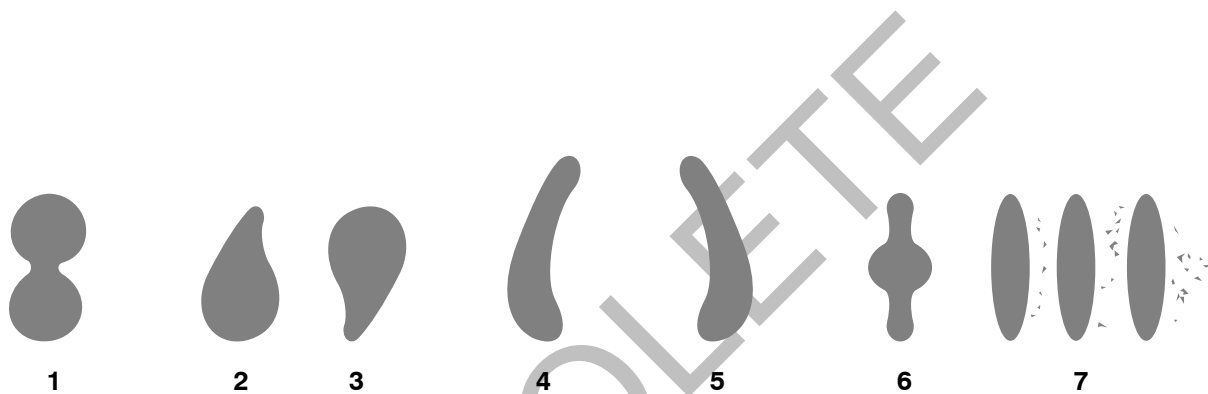

Figure 6-1 Common Spray Pattern Faults

- 1. Blown pattern
- 2. Heavy bottom
- 3. Heavy top
- 4. Heavy left side
- 5. Heavy right side
- 6. Heavy center
- 7. Spitting

## Electrostatic Troubleshooting

Problem	Possible Cause	Corrective Action
<b>1. Loss of wrap, poor transfer efficiency</b>	Low electrostatic voltage	Increase the voltage.
	Resistor or multiplier failure	Check the multiplier/tip resistor assembly with a megohmmeter for 277–340 megohms at 500 volts. If the reading is out of range, check the resistor tip separately. Tip resistor should measure 19.8–20.2 megohms. Refer to <i>Multiplier Continuity and Resistance Check</i> on page 6-7.
	Poorly grounded parts	Check conveyor chain, rollers, and part hangers for paint buildup. The resistance between the parts and the ground must be 1 megohm or less. 500 ohms or less is recommended for best results.
	Leaking packing cartridge	Check packing cartridge for leaks. Clean packing cartridge bore and install new packing cartridge and dielectric grease.
<b>2. No kV output from gun</b>	Damaged gun cable	Check the continuity of the cable wires, from pin to pin. Replace the cable if any opens or shorts are found. Refer to <i>Gun Cable Continuity Check</i> on page 6-8.
	Malfunctioning voltage multiplier	Check the continuity and resistance of the multiplier/resistor assembly with a megohmmeter for 277–340 megohms at 500 volts. No burn throughs or arc tracks should be visible on any gun parts. Refer to <i>Multiplier Continuity and Resistance Check</i> on page 6-7.
	Failed needle resistor	Check the resistor with a megohmmeter for 19.8–20.2 megohms at 500 volts.
	Malfunctioning Kinetix manual gun power supply	Check for 21 Vdc between cable end connectors. Refer to <i>Gun Cable Continuity Check</i> on page 6-8.
	Leaking packing cartridge	Check packing cartridge for leaks. Clean packing cartridge bore and install new packing cartridge and dielectric grease.
<i>Continued...</i>		

Problem	Possible Cause	Corrective Action
3. %kV reading on power supply incorrect	Input voltage switch is not in correct position	If the input voltage is 120 V, the switch in the power supply must be set to the 120 V position. Refer to the <i>Kinetix Manual Gun Power Supply</i> manual for more information.
4. Electrostatics will not shut off when trigger is released	Air leak in air hose	Check the air hose and fittings for leaks. Tighten the fittings or replace the hose.
	Air valve seat worn or damaged	Remove the air valve and inspect the sealing surface. Replace the air valve if worn or damaged.

## Multiplier Continuity and Resistance Check

See Figure 6-2.

The multiplier should measure 277–340 megohms at 500 volts.

1. Connect a probe on the megohmmeter to one of the three pins (1) on the end of the multiplier.
2. Connect the earth ground probe (common end) of the megohmmeter to the contact spring (2).

**NOTE:** Diodes require proper polarity for reading.

If the multiplier does not measure correctly, replace the multiplier. Refer to *Multiplier Replacement* on page 7-19.

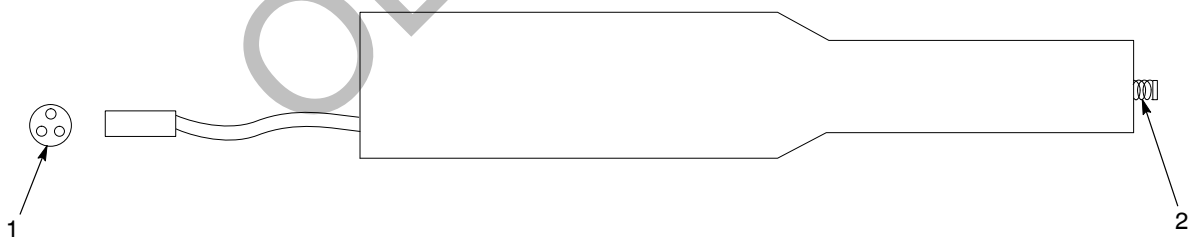

Figure 6-2 Multiplier Continuity and Resistance Check

1. Pins

2. Contact spring

## Gun Cable Continuity Check

See Figure 6-3.

Using an ohmmeter, check the continuity between the connections listed in Table 6-1 to complete a gun cable continuity check.

**NOTE:** If the continuity check fails make sure the kV on/off switch is in the on position.

Refer to Table 6-1.

1. Place an ohmmeter probe on the power supply connector.
2. Place another ohmmeter probe on the gun connector listed next to the power supply connector in Table 6-1.

Table 6-1 Gun Cable Continuity Check

Power Supply Connector	Gun Connector	Position
1	—	Open
2	3	Closed
3	1	Closed
4	2	Closed
5	—	Open
6	Bracket	Closed

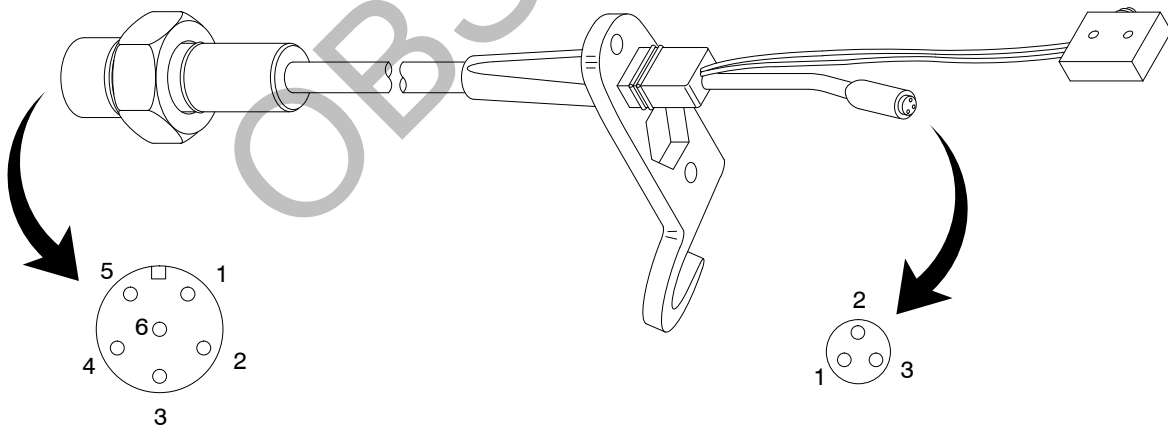

Figure 6-3 Gun Cable Continuity Check

## Section 7

# Repair



**WARNING:** Allow only qualified personnel to perform the following tasks. Follow the safety instructions in this document and all other related documentation.



**WARNING:** Shut off the gun control unit and ground the spray gun electrode to remove any residual charge. Failure to observe this warning could result in personal injury.



**WARNING:** Shut down the system and relieve all fluid and air pressures before performing these procedures. Failure to observe this warning could result in injection injury.



**WARNING:** Use only Nordson replacement parts to repair the spray gun. Deviating from the repair instructions, using unauthorized parts, or making unauthorized modifications can result in personal injury or death and/or the loss of approvals by agencies such as Factory Mutual Research Corporation (FM) or the Canadian Standards Association (CSA).



**CAUTION:** Do not overtighten threaded parts. Failure to observe this caution will result in equipment damage.

**NOTE:** Tighten all fittings until snug or to the specified torques. Because the spray gun uses O-ring seals, further tightening provides no benefit and could damage plastic threads.

**NOTE:** The numeric callouts in this section match the item numbers in the spray gun parts list. Refer to the *Parts* section for complete part descriptions and ordering information. Items in the repair section that are not called out in the spray gun parts list are identified with alphabetic callouts.

## Tools/Supplies Required

Before beginning any of the repair tasks described in this section, make sure you have the following tools and supplies:

- See Figure 7-1: Combination tool provided with your spray gun
- Needle tool (provided with your spray gun)
- Needle nose pliers (provided with your spray gun)
- $\frac{5}{32}$ -in. hex wrench
- Small flat-blade screwdriver
- Phillips-head screwdriver
- Service kits and replacement parts
- Removeable threadlocking adhesive
- Dielectric grease
- PTFE grease lubricant (MagnaLube G) or equivalent PTFE-based lubricant
- Pipe/thread/hydraulic sealant adhesive

**NOTE:** Refer to the *Parts* section for service kits and individual part numbers.

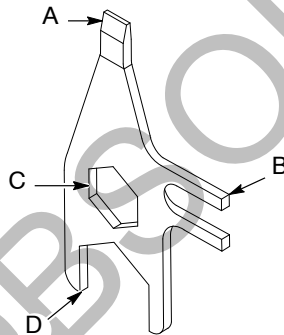

Figure 7-1 Combination Tool

- |                           |                   |
|---------------------------|-------------------|
| A. Screwdriver            | C. Fluid tip tool |
| B. Packing cartridge tool | D. Hose tool      |

## Air Cap and Fluid Tip Replacement

1. Turn off the gun control unit and ground the spray gun electrode to remove any residual charge.
2. Flush the fluid-delivery system, hoses, and spray gun.
3. Turn off the fluid-delivery system. Relieve system fluid pressures. Point the spray gun into the booth or grounded container and trigger it to relieve any residual pressure.



4. Disconnect the fluid hose from the spray gun. Move the spray gun to a clean, dry, flat surface.
5. See Figure 7-2. Unscrew the retaining ring (1) and air cap (A) assembly from the extension then unscrew the air cap from the retaining ring.



**CAUTION:** To prevent damage to the needle and fluid tip seat, trigger the spray gun to pull the needle back before removing or installing a fluid tip.

6. Trigger the spray gun to retract the needle (10). Place the hex on the combination tool over the hex on the fluid tip (B) and unscrew it from the extension.
7. Make sure the O-ring (D) is installed in the groove in the fluid tip. Lubricate the O-ring with dielectric grease.

**NOTE:** Place the O-ring in the groove closest to the rear of the fluid tip.

8. Make sure the conductive back-up ring (C) is installed on the fluid tip.



**CAUTION:** Do not overtighten threaded parts. Failure to observe this caution will result in equipment damage.



**CAUTION:** To prevent damage to the needle and fluid tip seat, trigger the spray gun to pull the needle back before removing or installing a fluid tip.

9. Trigger the spray gun to retract the needle. Screw the new fluid tip in the extension. Tighten the fluid tip snugly. Do not overtighten it or you could damage the extension threads.
10. Screw the new air cap into the retaining ring until it bottoms out in the groove and turns freely then screw the retaining ring onto the extension and tighten it securely by hand.

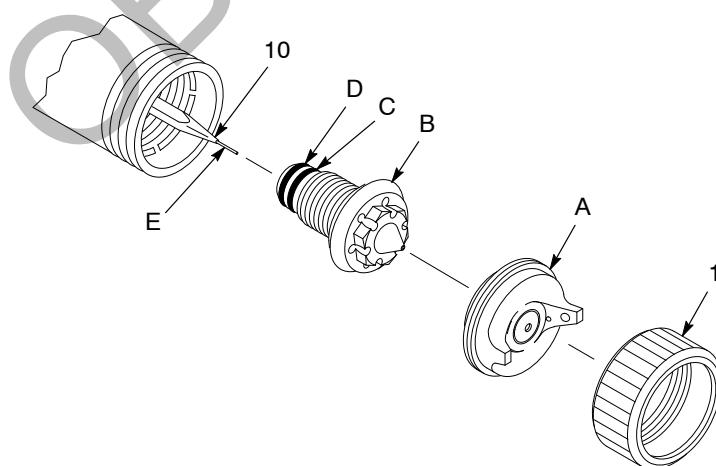

Figure 7-2 Air Cap and Fluid Tip Replacement

- |                   |                            |                               |
|-------------------|----------------------------|-------------------------------|
| 1. Retaining ring | B. Fluid tip               | D. O-ring                     |
| 10. Needle        | C. Conductive back-up ring | E. Electrode (part of needle) |
| A. Air cap        |                            |                               |

## Trigger Lock Replacement



**WARNING:** Never operate the spray gun with a worn or damaged trigger lock. Failure to observe this warning could result in injury.

1. See Figure 7-3. Drive the pin (23) out of the trigger lock (22) and handle (15) with a small dowel pin.
2. Hold the new trigger lock in place and drive the new pin through the lock and handle holes. The pin should be approximately flush with the trigger lock surfaces.

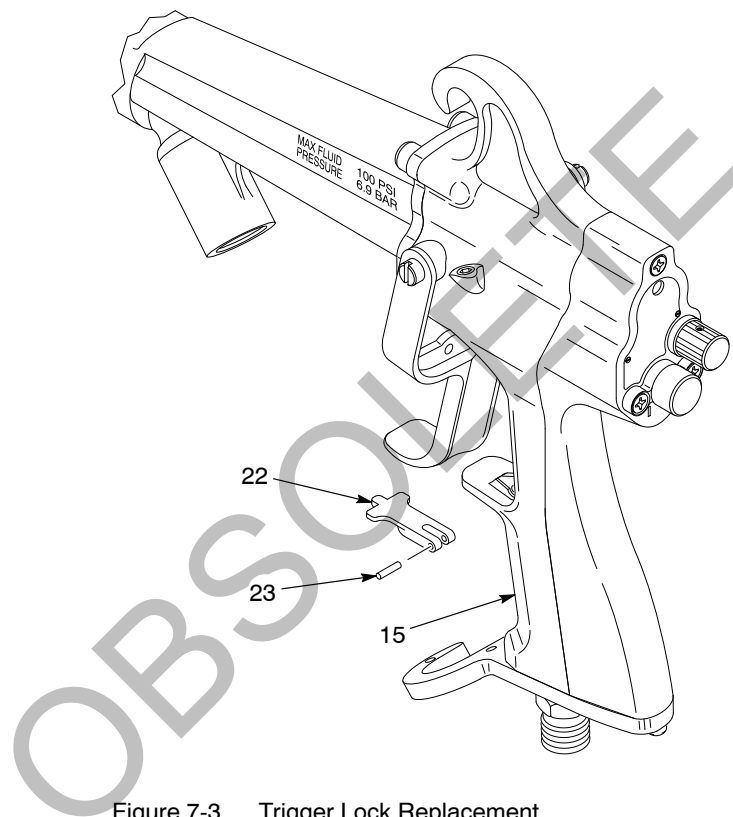

Figure 7-3 Trigger Lock Replacement

- 15. Handle
- 22. Trigger lock

- 23. Pin

## Air Inlet Fitting Replacement

See Figure 7-4.

### Air Inlet Fitting Removal

1. Remove the horn air adjust valve knob (42) by loosening its set screw (41).
2. **3/8-in. OD Fluid Tube Spray Guns Only:** Remove the two screws (57) that attach the elbow (58) to the cable bracket (A) and remove the fluid tube from the bracket.  
**1/4-in. ID Fluid Hose Spray Guns Only:** Remove the two screws (57) that attach the hose flange to the the cable bracket (A).
3. Remove the screws (28, 40) to remove the back cover (46) and the cable bracket (A) from the handle.
4. Slowly pull the back cover away from the gun handle so you do not disconnect the cable connector (B) from the multiplier connector (C) or pull on the kV actuator switch wires.

**NOTE:** The cable is secured in ribbed slots (D) in the back of the handle.

5. Unscrew the air inlet fitting/coupling (30) from the handle base and replace its O-ring (29). Lubricate the O-ring with MagnaLube G or an equivalent PTFE-based lubricant.

### Air Inlet Fitting Installation

1. Screw the end of the air inlet fitting/coupling (30) into the handle base. Tighten the fitting finger-tight.
2. Install the cable bracket (A) over the fitting hex. Tighten or loosen the air inlet fitting slightly to align the fitting to the hex in the bracket.

**NOTE:** Make sure the cable is snapped into the ribbed slots (D) in the back of the handle.



**CAUTION:** Be careful not to pinch the cable between the handle and the back cover as the back cover is tightened.

3. Secure the cable bracket to the handle and back cover with the two screws (28). Tighten the screws to 1.36–1.69 N•m (12–15 in.-lb).
4. Install the back cover (46) of the spray gun with the three screws (40). Tighten the screws to 0.9–1.13 N•m (8–10 in.-lb).
5. Install the fluid hose or fluid tube into the cable bracket.
6. Secure the horn air adjust valve knob (42) on the back cover by tightening its set screw (41).

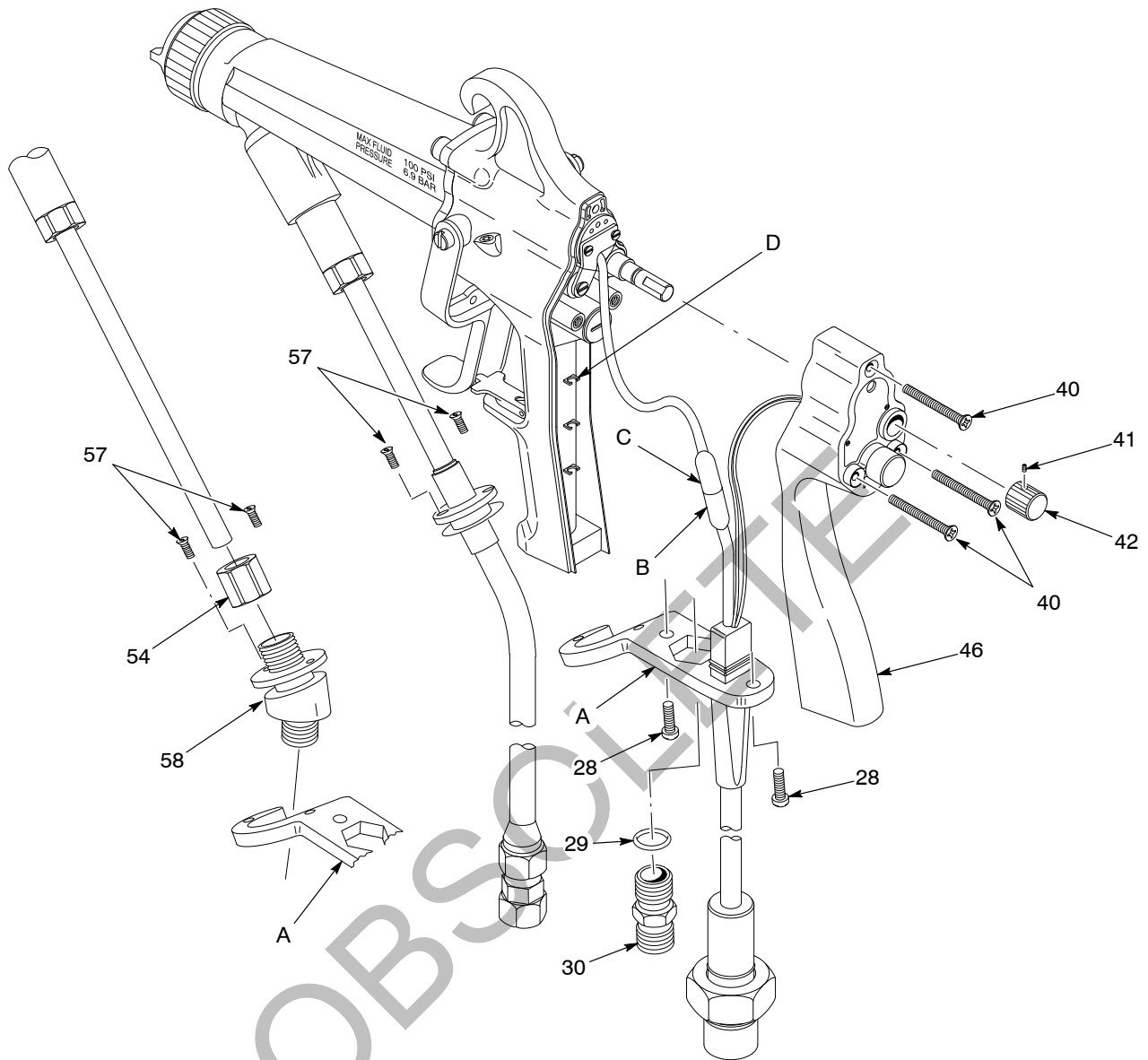

Figure 7-4 Air Inlet Fitting Replacement

- |                                |                                |                         |
|--------------------------------|--------------------------------|-------------------------|
| 28. Screws                     | 42. Horn air adjust valve knob | A. Cable bracket        |
| 29. O-ring                     | 46. Back cover                 | B. Cable connector      |
| 30. Air inlet fitting/coupling | 54. Ferrule nut                | C. Multiplier connector |
| 40. Screws                     | 57. Screws                     | D. Ribbed slots         |
| 41. Set screw                  | 58. Elbow                      |                         |

## Needle Replacement

**NOTE:** You do not need to completely disassembly the spray gun for this procedure. To replace the entire packing cartridge and needle assembly, refer to *Packing Cartridge and Needle Replacement* on page 7-9.

### *Preparation*

1. Turn off the gun control unit and ground the spray gun electrode to remove any residual charge.
2. Flush the fluid-delivery system, hoses, and spray gun.
3. Turn off the fluid-delivery system. Relieve system fluid pressures. Point the spray gun into the booth or grounded container and activate it to relieve any residual pressure.
4. Disconnect the fluid hose from the spray gun and move the spray gun to a clean, dry, flat surface.
5. Remove the air cap and fluid tip as described in *Air Cap and Fluid Tip Replacement* on page 7-2.

### *Needle Removal*

**NOTE:** Be careful not to bend the connecting wire on the packing cartridge.

1. See Figure 7-5. Insert the bent needle nose pliers into the gun body and grasp the square needle fitting on the end of the packing cartridge.
2. Line up the open end of the needle tool over the needle and slide it down over the needle.
3. Hold the pliers tightly then begin turning the needle removing tool to loosen the needle from the packing cartridge.

**NOTE:** If the needle does not break lose easily, make sure the pliers are preventing the square fitting from turning. If the needle still does not loosen, it may be necessary to remove the packing cartridge to replace the needle. Refer to *Packing Cartridge and Needle Replacement* on page 7-9.

4. Once it is loose, remove the needle.

**NOTE:** See Figure 7-7. The contact spring (11) may come out with the needle.

**Needle Removal** (contd)

Figure 7-5 Needle Replacement

*Note:* The bent needle nose pliers and the needle tool are shipped with the spray gun.

**Needle Installation**

1. Inspect the extension bore and the threads of the packing cartridge fitting for residual material. If necessary, clean them using a squirt bottle filled with a compatible solvent.
2. See Figure 7-7. Inspect the contact spring (11) and replace if damaged.
3. Thread the contact spring onto the needle so the wide end is towards the packing cartridge.

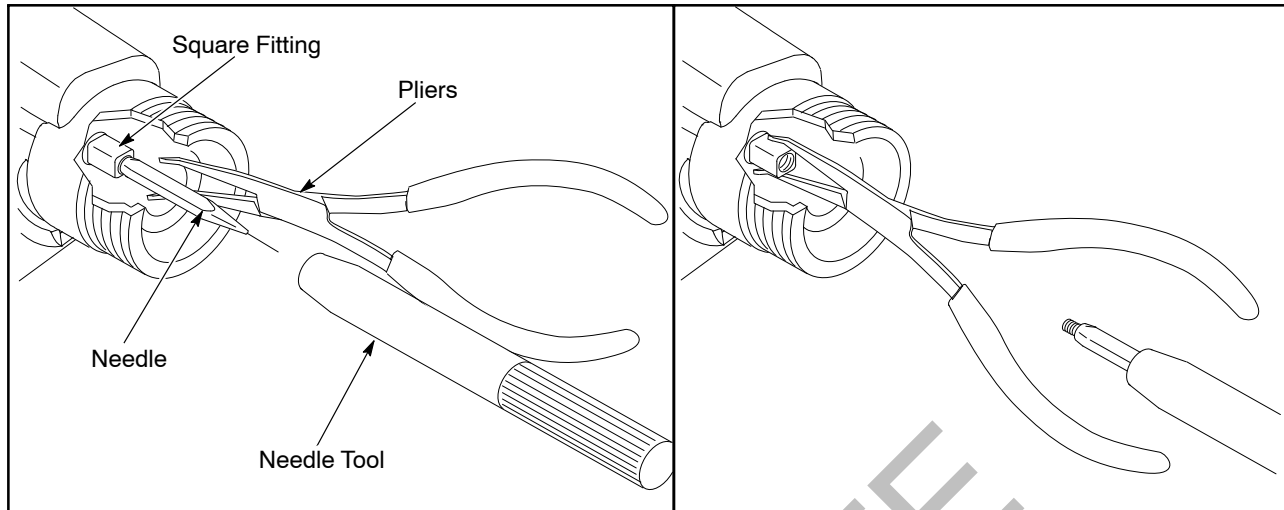
**NOTE:** A removable threadlocking adhesive can be applied to the threads of the new needle (10) if there are problems with the needle backing out.

4. Screw the new needle into the square needle fitting. Tighten the needle finger tight. Wipe off excess adhesive, if used.

**NOTE:** Be careful not to bend the connecting wire on the packing cartridge.

5. See Figure 7-5. Insert the bent needle nose pliers into the gun body and grasp the square needle fitting on the end of the packing cartridge.
6. Line up the open end of the needle tool over the needle and slide it down over the needle.
7. Hold the pliers tight then begin turning the needle tool to tighten the needle into the packing cartridge.
8. Inspect the needle and packing cartridge fitting to make sure that the needle threads are completely engaged. If not, remove and install the needle again.
9. Install the retaining ring, air cap, and fluid tip as described in *Air Cap and Fluid Tip Replacement* on page 7-2.

## Packing Cartridge and Needle Replacement



**CAUTION:** If the packing cartridge leaks, it is important to thoroughly clean the packing cartridge bore in the extension with a compatible non-conductive solvent to remove any residual coating material. Failure to do so may result in loss of kV.



**CAUTION:** Do not overtighten threaded parts. Failure to observe this caution may result in equipment damage.

The Kinetix spray gun is shipped with the standard gold packing cartridge. This durable packing cartridge is appropriate for most coating materials. Use the optional PTFE packing cartridge with harsh chemical solvents such as MEK.

The only serviceable parts of the packing cartridge are the external O-ring and back-up ring. If replacing the O-ring and back-up ring does not stop the packing cartridge from leaking, you must replace the packing cartridge.

The needle is not a component of the packing cartridge. To replace the needle only, refer to *Needle Replacement* on page 7-7. You must order the needle separately.

### Preparation

1. Turn off the gun control unit and ground the spray gun electrode to remove any residual charge.
2. Flush the fluid-delivery system, hoses, and spray gun.
3. Turn off the fluid-delivery system. Relieve system fluid pressures. Point the spray gun into the booth or grounded container and trigger it to relieve any residual pressure.
4. Disconnect the fluid hose from the spray gun. Move the spray gun to a clean, dry, flat surface.
5. Remove the air cap and fluid tip as described in *Air Cap and Fluid Tip Replacement* on page 7-2.

### Spray Gun Disassembly

See Figure 7-6.

1. **3/8-in. OD Fluid Tube Spray Guns Only:** Remove the two screws (57) that attach the elbow (58) to the cable bracket (A) and remove the fluid tube from the bracket.  
**1/4-in. ID Fluid Hose Spray Guns Only:** Remove the two screws (57) that attach the hose flange to the the cable bracket (A).
2. Remove the two pivot screws (26) and the trigger (27).

### **Spray Gun Disassembly** *(contd)*

3. Using a  $\frac{5}{32}$ -in. hex wrench, remove the four socket-head screws (3) to remove the extension (2) from the handle (15). Do not lose the two face-seal O-rings (36) or the large face-seal O-ring (4) installed in the handle.

**NOTE:** Hold onto the extension as you remove it from the handle. The packing cartridge spring will push the extension away from the handle.

4. Carefully slide the extension off of the multiplier (5). Do not lose the packing cartridge spring (21).

OBSOLETE



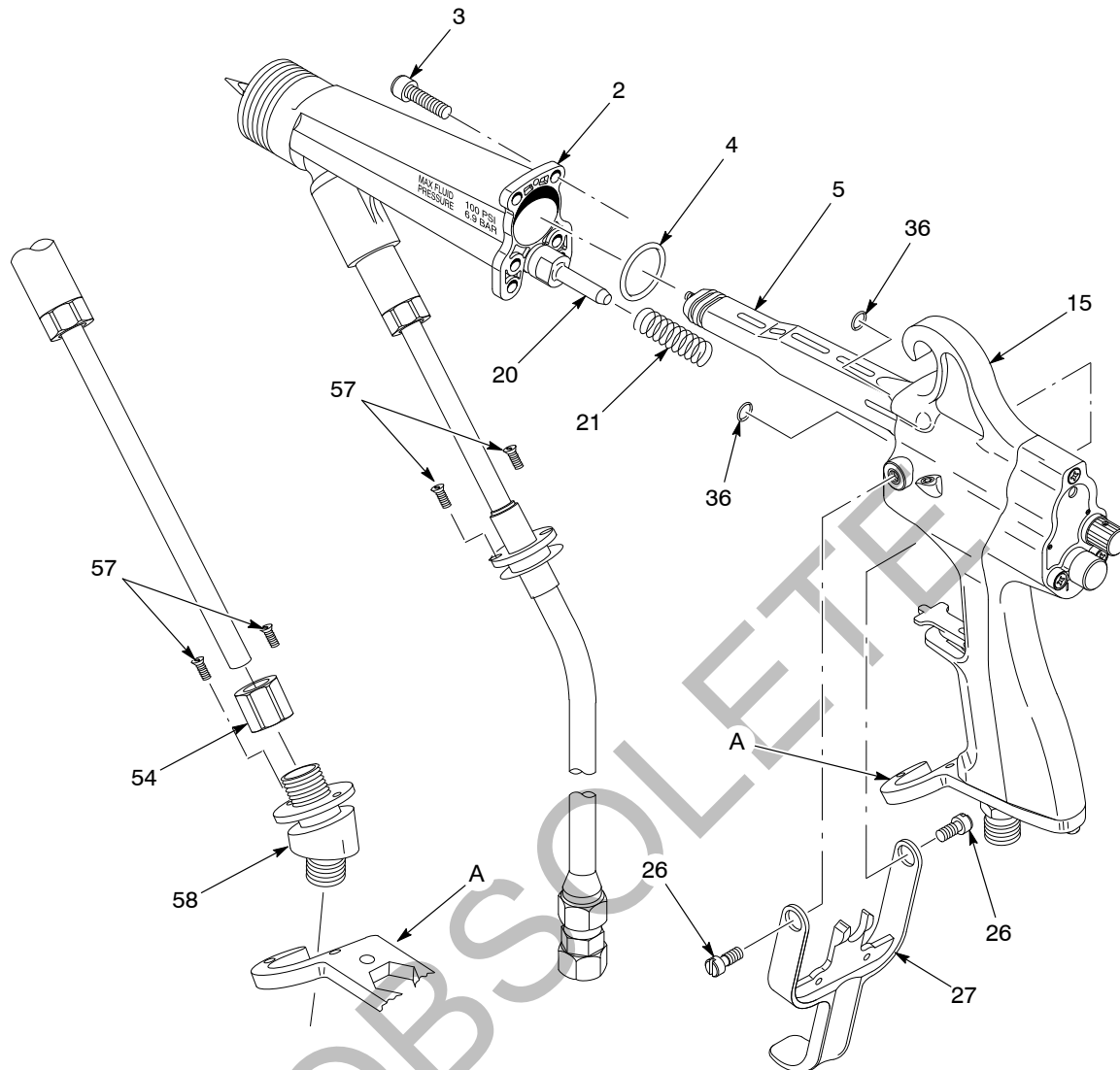

Figure 7-6 Spray Gun Disassembly

- |                           |                              |                  |
|---------------------------|------------------------------|------------------|
| 2. Extension              | 20. Puller                   | 54. Ferrule nut  |
| 3. Socket-head screws     | 21. Packing cartridge spring | 57. Screws       |
| 4. Large face-seal O-ring | 26. Pivot screws             | 58. Elbow        |
| 5. Multiplier             | 27. Trigger                  | A. Cable bracket |
| 15. Handle                | 36. Face-seal O-rings        |                  |

## Packing Cartridge and Needle Removal

See Figure 7-7.

1. Hold the the puller (20) by its flats and unscrew it from the pull shaft (16).
2. Push the pull shaft forward and unscrew the packing cartridge retainer (19) with the combination tool.
3. Pull the pull shaft out of the back of the extension to remove the pull shaft, packing cartridge (14), and sleeve retainer (18). Do not bend the connecting wire (A).
4. Remove the sleeve retainer from the pull shaft and unscrew the pull shaft from the packing cartridge.
5. Clean the extension fluid bores with a round, soft-bristled brush and a compatible non-conductive solvent. For thorough cleaning, remove the fluid fittings from the extension.
6. Inspect the packing cartridge. If the packing cartridge is damaged, replace it with a new one.
7. Inspect and replace the packing cartridge O-ring (12) and conductive back-up ring (13) if they are damaged. Lubricate the packing cartridge with MagnaLube G or an equivalent PTFE-based lubricant.

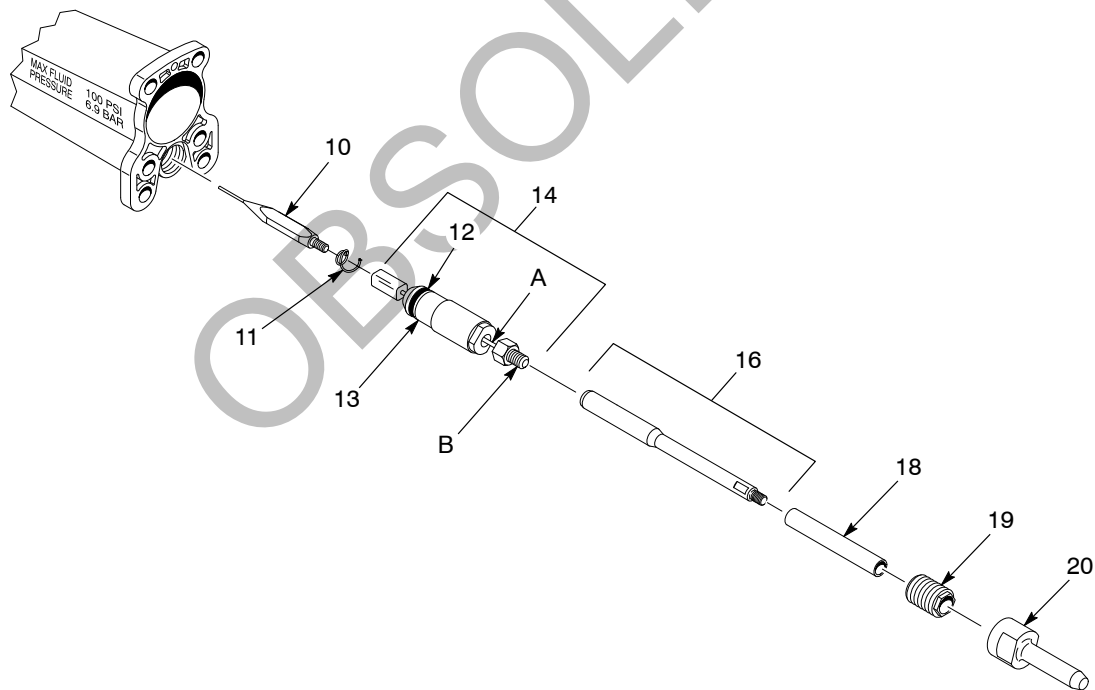

Figure 7-7 Packing Cartridge and Needle Replacement

- |                             |                                |                    |
|-----------------------------|--------------------------------|--------------------|
| 10. Needle                  | 14. Packing cartridge          | 20. Puller         |
| 11. Contact spring          | 16. Pull shaft                 | A. Connecting wire |
| 12. O-ring                  | 18. Sleeve retainer            | B. Puller fitting  |
| 13. Conductive back-up ring | 19. Packing cartridge retainer |                    |

## **Packing Cartridge and Needle Removal** (contd)

8. Generously lubricate both ends of the packing cartridge wire with MagnaLube G or an equivalent PTFE-based lubricant. Push and pull the wire 40–50 times to work the lubricant into the packing cartridge.
9. If the needle (10) is damaged, replace it as follows:
  - a. Hold the needle fitting on the end of the packing cartridge assembly with a wrench, slide the needle removal tool over the needle and unscrew the needle from the needle fitting.

**NOTE:** A removeable thread-locking adhesive can be applied to the threads of the new needle if there are problems with the needle backing out.

**NOTE:** Inspect the contact spring (11) and replace if damaged.

**NOTE:** Make sure the contact spring is installed on the needle with the wide end towards the packing cartridge.

- b. Screw the new needle into the needle fitting. Tighten the needle finger tight until it bottoms against the fitting. Wipe off excess adhesive, if used.

## **Packing Cartridge and Needle Installation**

See Figure 7-7.

**NOTE:** Make sure all residual coating material has been removed from all of the parts before installing.

1. Apply a removeable threadlocking adhesive to the threads of the packing cartridge puller fitting (B).
2. Screw the pull shaft (16) onto the packing cartridge (14).



**CAUTION:** Apply dielectric grease as instructed in steps 3, 4, and 5. If it is not applied as instructed, damage to the spray gun is likely and spray gun performance and safety may be compromised.

3. Apply a liberal amount of dielectric grease to the puller fitting and the pull shaft then insert the packing cartridge assembly and pull shaft into the extension from the back.
4. Apply a thin coating of dielectric grease to the outside of the sleeve retainer (18) then slide the sleeve retainer over the pull shaft and push it down into the fluid bore.
5. Generously lubricate the end of the pull shaft and the inside of the packing cartridge retainer (19) with MagnaLube G or an equivalent PTFE-based lubricant.
6. Apply a thin coating of dielectric grease to the threads of the packing cartridge retainer then screw the packing cartridge retainer into the extension.
7. Push the pull shaft forward and tighten the packing cartridge retainer with the combination tool hand-tight.

8. Wipe off excess dielectric grease.
9. Apply a removeable threadlocking adhesive to the threads of the pull shaft and screw the puller (20) onto the pull shaft.

## ***Spray Gun Assembly***

See Figure 7-6.

1. Make sure that the multiplier (5) is clean and well lubricated with dielectric grease. Grease the front  $\frac{1}{3}$  of the multiplier and its contact spring if necessary.
2. Generously lubricate the outside diameter of the puller (20) and the packing cartridge spring (21) with MagnaLube G or an equivalent PTFE-based lubricant.
3. Generously lubricate the inside of the fluid return spring bore in the handle with MagnaLube G or an equivalent PTFE-based lubricant.
4. Insert the packing cartridge spring and the end of the puller (20) into the handle trigger bore and mate together the handle (15) and the extension (2).
5. Secure the extension to the handle with the four socket-head screws (3). Tighten the screws to 2.27–2.83 N•m (20–25 in.-lb).
6. Insert the pivot screws (26) through the holes in the trigger (27) and into the greased insert in the handle. Make sure the trigger forks engage the pull shaft. Tighten the screws to 0.90–1.13 N•m (8–10 in.-lb).
7. Install the fluid hose or fluid tube into the cable bracket (A).

**NOTE:** Pull the trigger and make sure it presses the air valve stem into the handle and pulls the needle into the spray gun.

8. Install the air cap and fluid tip as described in *Air Cap and Fluid Tip Replacement* on page 7-2.
9. Secure the fluid hose to the bracket and turn on the fluid-delivery system.
10. Turn on the gun control unit.
11. Make sure the spray gun is working correctly. Adjust fluid flow rate and atomization as desired. Refer to *Fluid Pressure and Flow Rate Adjustments* on page 4-2 and *Spray Pattern and Atomization Adjustments* on page 4-3.

# Horn Air Adjust Valve Replacement

See Figure 7-8.

## Valve Removal

1. Loosen the set screw (41) in the horn air adjust valve knob (42) with a  $\frac{1}{16}$ -in. hex wrench. Remove the knob from the valve.
2.  **$\frac{3}{8}$ -in. OD Fluid Tube Spray Guns Only:** Remove the two screws (57) securing the elbow (58) to the cable bracket (A) and remove the fluid tube from the bracket.  
 **$\frac{1}{4}$ -in. ID Fluid Hose Spray Guns Only:** Remove the two screws (57) securing the hose flange to the the cable bracket (A).
3. Remove the screws (28, 40) and the back cover (46) from the handle and the bracket.
4. Slowly pull the back cover away from the handle so you do not disconnect the cable connector (B) from the multiplier connector (C) or pull on the kV actuator switch wires.

**NOTE:** The cable is secured in ribbed slots (D) in the back of the handle.

5. Install the horn air adjust valve knob (42) on the horn air adjust valve (38) and tighten the set screw. Unscrew the valve from the handle.
6. Inspect the horn air adjust valve and its O-rings (36, 39). Replace any damaged parts. Lubricate the O-ring (36) with dielectric grease. Lubricate the O-ring (39) with MagnaLube G or an equivalent PTFE-based lubricant.

## Valve Installation

1. Install the horn air adjust valve in the handle and then loosen the set screw (41) and remove the horn air adjust valve knob (42) from the valve.

**NOTE:** Make sure the cable is snapped into the ribbed slots (D) in the back of the handle.



**CAUTION:** Be careful not to pinch the cable between the handle and the back cover as the back cover is tightened.

2. Secure the bracket to the handle and back cover using the two screws (28). Tighten the screws to 1.36–1.69 N•m (12–15 in.-lb).
3. Install the back cover using the screws (40). Tighten the screws to 0.9–1.13 N•m (8–10 in.-lb).
4. Install the fluid hose or fluid tube into the cable bracket.
5. Install the horn air adjust valve knob on the valve and tighten the set screw.

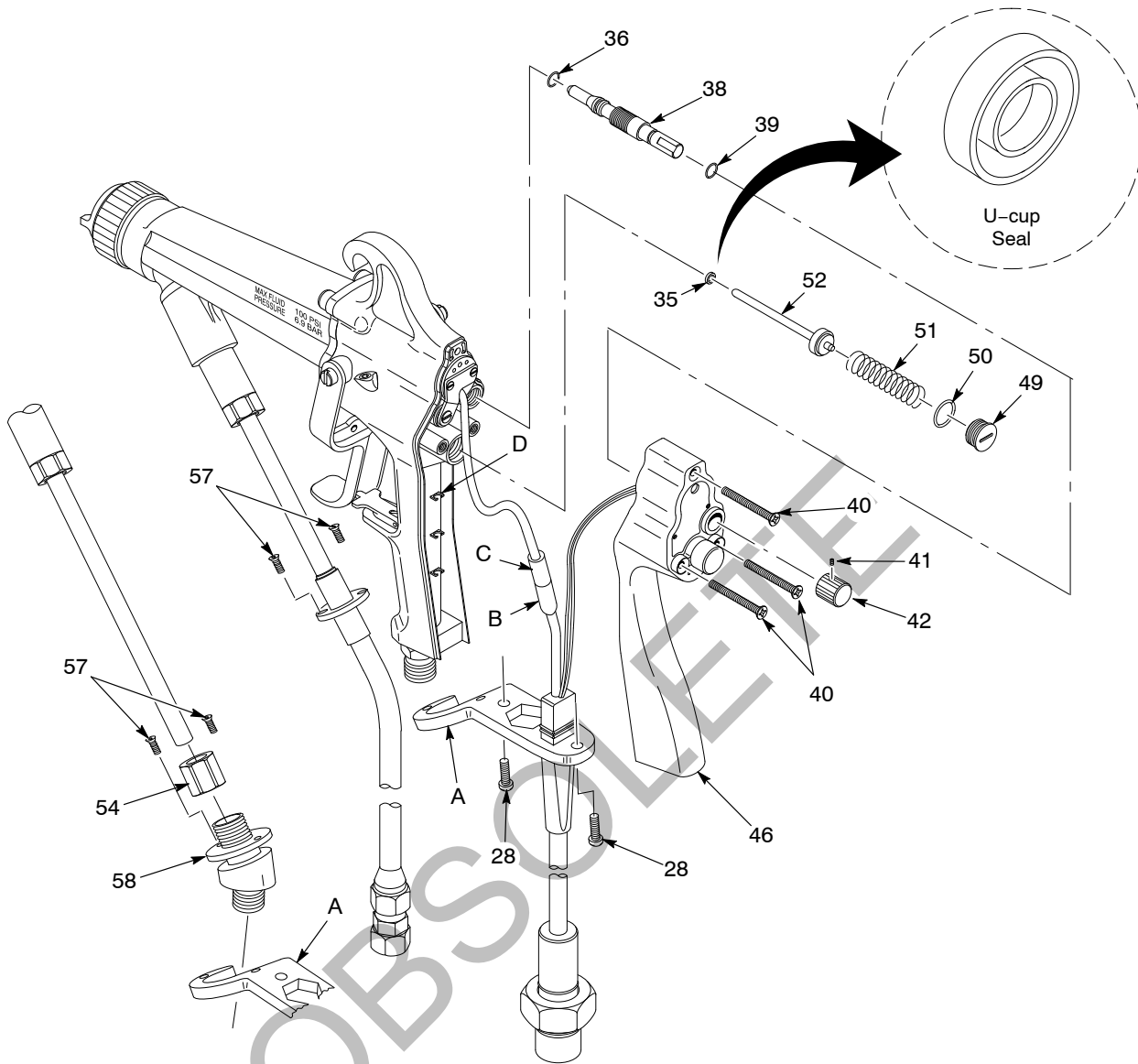

Figure 7-8 Horn Adjust Valve and Air Valve Replacement

- |                           |                                |                         |
|---------------------------|--------------------------------|-------------------------|
| 28. Screws                | 42. Horn air adjust valve knob | 57. Screws              |
| 35. U-cup seal            | 46. Back cover                 | 58. Elbow               |
| 36. O-rings               | 49. Air valve plug             | A. Cable bracket        |
| 38. Horn air adjust valve | 50. O-ring                     | B. Cable connector      |
| 39. Split O-ring          | 51. Air valve spring           | C. Multiplier connector |
| 40. Screws                | 52. Air valve stem             | D. Ribbed slots         |
| 41. Set screw             | 54. Ferrule nut                |                         |

## Air Valve Replacement



**CAUTION:** A worn or damaged air valve could result in an air leak which triggers on the electrostatics. Replace a worn or damaged air valve immediately.

See Figure 7-8.

### *Air Valve Removal*

1. Loosen the set screw (41) in the horn air adjust valve knob (42) with a  $\frac{1}{16}$ -in. hex wrench. Remove the knob from the valve.
2.  **$\frac{3}{8}$ -in. OD Fluid Tube Spray Guns Only:** Remove the two screws (57) that attach the elbow (58) to the cable bracket (A) and remove the fluid tube from the bracket.  
 **$\frac{1}{4}$ -in. ID Fluid Hose Spray Guns Only:** Remove the two screws (57) that attach the hose flange to the the cable bracket (A).
3. Remove the screws (28, 40) to remove the back cover (46) from the handle and the bracket.
4. Slowly pull the back cover away from the handle so you do not disconnect the cable connector (B) from the multiplier connector (C) or pull on the kV actuator switch wires.

**NOTE:** The cable is secured in ribbed slots (E) in the back of the handle.

5. Remove the air valve plug (49) with the combination tool. Inspect the O-ring (50). Replace it if it is damaged. Lubricate the O-ring with MagnaLube G or an equivalent PTFE-based lubricant.
6. Remove the air valve spring (51) from the handle. Do not lose the spring.
7. The air valve stem (52) may come out with the spring. If it does not, push it out from the trigger side of the handle. Do not use any tools to force the stem; you may damage the U-cup seal (35) or stem bore.
8. Inspect the air valve stem. Replace the valve stem if the elastomeric seat is damaged or the stem is worn or damaged.

**NOTE:** If there is no damage to the air valve stem, and air does not leak from the stem bore when the trigger is pulled, you should not have to replace the U-cup seal.

9. If necessary, remove and replace the U-cup seal:
  - a. Use a small pick to pull the U-cup seal out of the handle.
  - b. Install a new U-cup seal on the air valve stem with the U facing outward. Carefully insert the stem into the stem bore and seat the U-cup into the recess surrounding the stem bore.
  - c. Remove the air valve stem. Use the blunt end of a dowel with a larger diameter than the inside diameter of the U-cup seal to press the seal into the bore. Make sure the end of the dowel does not have sharp edges.

## ***Air Valve Installation***

See Figure 7-8

1. If the air valve spring (51) came off the air valve stem (52), snap it back on. The air valve spring must be attached to the air valve stem or the gun will not work properly.
2. Lubricate the U-cup seal (35) with MagnaLube G or an equivalent PTFE-based lubricant. Insert the air valve stem through the U-cup seal and through the stem bore.
3. Push the valve stem back and forth through the U-cup several times with your fingers. Pull the spring and air valve stem back out of the bore. If the U-cup seal comes out with the valve stem, reinstall it and reseal it.
4. Lubricate the air valve plug O-ring (50) with MagnaLube G or an equivalent PTFE-based lubricant and screw the air valve plug (49) into the handle until it is snug.

**NOTE:** Make sure the cable is snapped into the ribbed slots (E) in the back of the handle.



**CAUTION:** Be careful not to pinch the cable between the handle and the back cover as the back cover is tightened.

5. Secure the bracket to the handle and back cover using the two screws (28). Tighten the screws to 1.36–1.69 N•m (12–15 in.-lb).
6. Install the back cover (46) with the screws (40). Tighten the screws to 0.9–1.13 N•m (8–10 in.-lb).
7. Install the fluid hose or fluid tube into the cable bracket.
8. Install the horn air adjust valve knob (42) on the back cover and tighten the set screw (41).



# Multiplier Replacement

See Figure 7-9.

## Multiplier Removal

1. Turn off the gun control unit and ground the spray gun electrode to remove any residual charge.
2. Turn off the fluid-delivery system and supply air and relieve the fluid and air pressures.
3. **3/8-in. OD Fluid Tube Spray Guns Only:** Remove the two screws (57) that attach the elbow (58) to the cable bracket (A) and remove the fluid tube from the bracket.  
**1/4-in. ID Fluid Hose Spray Guns Only:** Remove the two screws (57) that attach the hose flange to the the cable bracket (A).
4. Loosen the set screw (41) in the horn air adjust valve knob (42) with a 1/16-in. hex wrench. Remove the knob from the valve.
5. Remove the screws (28, 40) to remove the back cover (46) from the handle and cable bracket (A).
6. Slowly pull the back cover away from the handle and disconnect the cable connector (B) from the small connector (C).

**NOTE:** The cable is secured in ribbed slots (D) in the back of the handle.

7. Remove the screw (9) securing the heat sink bracket (7) to the handle.



**CAUTION:** Do not pull the multiplier out of the spray gun by its wires.

8. Pull the multiplier (5) out of the spray gun handle (15).

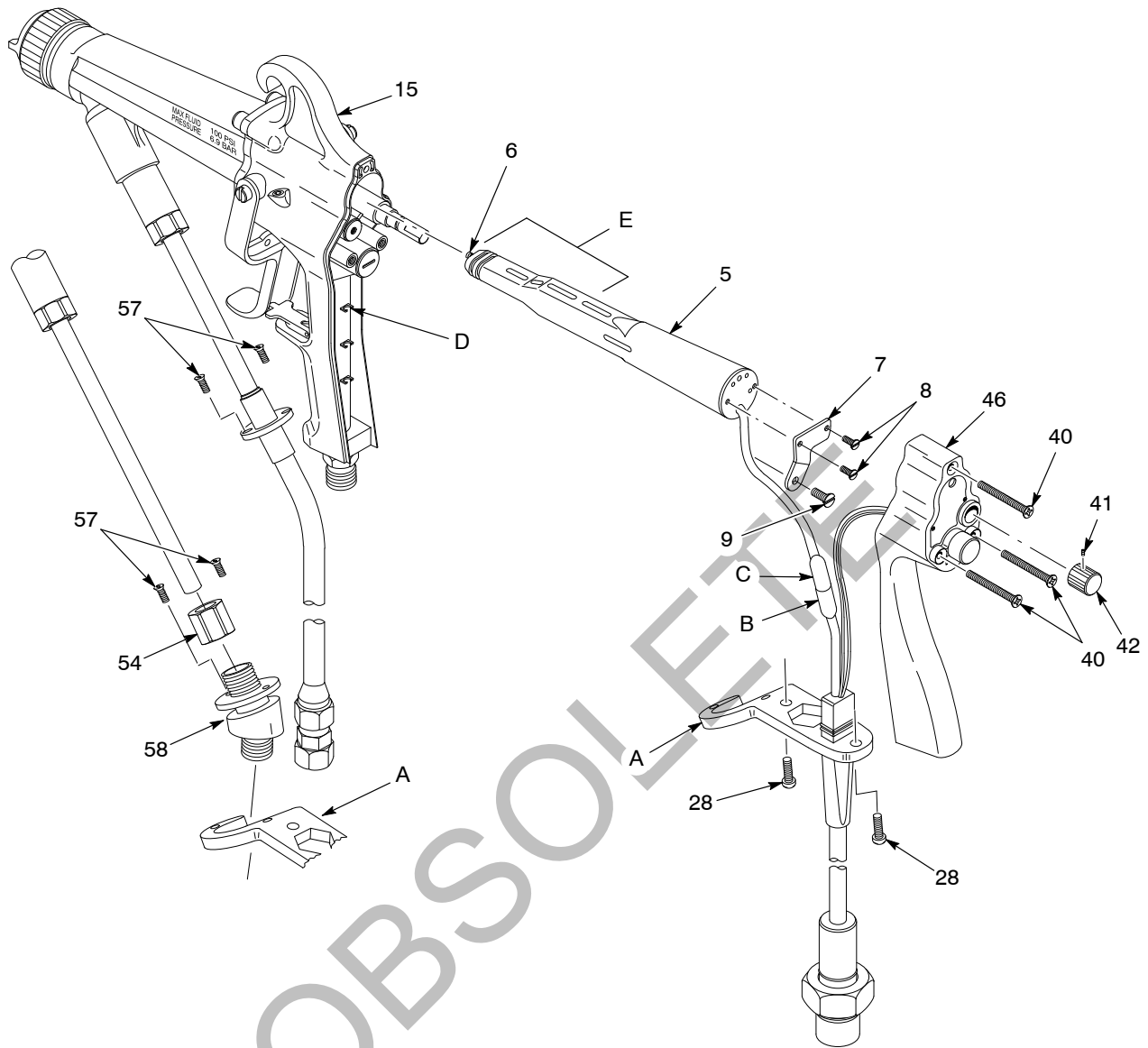

Figure 7-9 Multiplier Replacement

- |                      |                                |                         |
|----------------------|--------------------------------|-------------------------|
| 5. Multiplier        | 40. Screws                     | 58. Elbow               |
| 6. Contact spring    | 41. Set screw                  | A. Cable bracket        |
| 7. Heat sink bracket | 42. Horn air adjust valve knob | B. Cable connector      |
| 8. Screws            | 46. Back cover                 | C. Multiplier connector |
| 9. Screw             | 54. Ferrule nut                | D. Ribbed slots         |
| 15. Handle           | 57. Screws                     | E. Dielectric grease    |
| 28. Screws           |                                |                         |

## New Multiplier Installation

See Figure 7-9.

1. Check the continuity of the new multiplier. Refer to *Multiplier Continuity and Resistance Check* on page 6-7.
2. Remove the screws (8) and heat sink bracket (7) from the old multiplier and install them on the new multiplier.



**CAUTION:** Apply dielectric grease as instructed. If dielectric grease is not applied correctly damage to the spray gun is likely and spray gun performance and safety may be compromised.

3. Make sure that the contact spring (6) is in place. Apply a liberal amount of dielectric grease (E) to the front  $\frac{1}{3}$  of the new multiplier (5) and its contact spring.
4. Push the new multiplier through the handle (15) and into the extension.
5. Attach the heat sink bracket (7) to the gun handle with the screw (9).
6. Connect the cable connector (B) to the small connector (C).

**NOTE:** Make sure the cable is snapped into the ribbed slots (D) in the back of the handle.



**CAUTION:** Be careful not to pinch the cable between the handle and the back cover as the back cover is tightened.

7. Secure the bracket to the handle and back cover with the two screws (28). Tighten the screws to 1.36–1.69 N•m (12–15 in.-lb).
8. Install the back cover (46). Tighten the screws (40) to 0.9–1.13 N•m (8–10 in.-lb).
9. Install the fluid hose or fluid tube into the cable bracket.
10. Install the horn air adjust valve knob (42) on the back cover and tighten the set screw (41).
11. Turn on the gun control unit and test gun operation.

# Gun Cable Replacement

See Figure 7-10.

## Cable Removal

1. Turn off the gun control unit and ground the spray gun electrode to remove any residual charge.
  2.  **$\frac{3}{8}$ -in. OD Fluid Tube Spray Guns Only:** Remove the two screws (57) that attach the elbow (58) to the cable bracket (A) and remove the fluid tube from the bracket.  
 **$\frac{1}{4}$ -in. ID Fluid Hose Spray Guns Only:** Remove the two screws (57) that attach the hose flange to the the cable bracket (A).
  3. Loosen the set screw (41) in the horn air adjust valve knob (42) with a  $\frac{1}{16}$ -in. hex wrench. Remove the knob from the valve.
  4. Remove the screws (28, 40) to remove the back cover (46) and ground bracket from the handle.
  5. Slowly pull the back cover away from the handle and disconnect the cable connector (B) from the multiplier connector (C).
- NOTE:** The cable is secured in ribbed slots (D) in the back of the handle.
6. Remove the screws (34) and washers (33) securing the actuator switch (32) and electrostatic cable (31).

**NOTE:** Be careful not to lose the washers or bend the actuator switch.

## Cable Installation

1. Secure the actuator switch (32) and electrostatic cable (31) to the back cover with its screws (34) and washers (33).

**NOTE:** The actuator switch should be placed as shown in Figure 7-10. The wires should be to the left of the switch and the metal clip should be placed behind the switch so that its arm extends along the bottom of the switch from the right.

2. Connect the cable connector (B) to the multiplier connector (C).

**NOTE:** Make sure the cable is snapped into the ribbed slots (D) in the back of the handle.



**CAUTION:** Be careful not to pinch the cable between the handle and the back cover as the back cover is tightened.

3. Secure the cable bracket to the handle and back cover using the two screws (28). Tighten the screws to 1.36–1.69 N•m (12–15 in.-lb).
4. Install the back cover (46) with the screws (40). Tighten the screws to 0.9–1.13 N•m (8–10 in.-lb).
5. Install the fluid hose or fluid tube into the ground bracket.
6. Install the horn air adjust valve knob (42) on the back cover and tighten the set screw (41). Align the set screw with the flat on the knob.
7. Turn on the gun control unit and test gun operation.

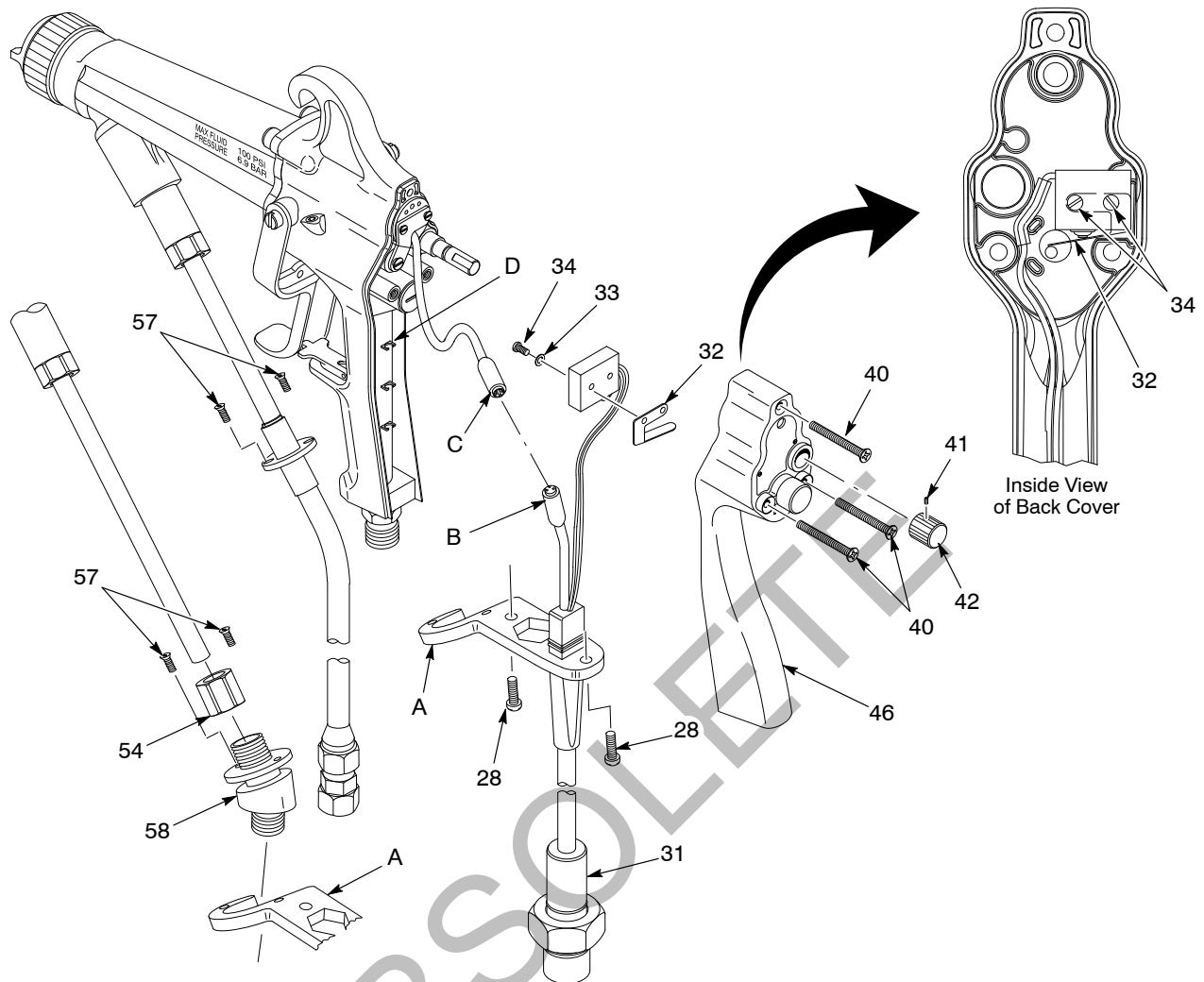

Figure 7-10 Gun Cable Replacement

- |                         |                                |                         |
|-------------------------|--------------------------------|-------------------------|
| 28. Screws              | 41. Set screw                  | 58. Elbow               |
| 31. Electrostatic cable | 42. Horn air adjust valve knob | A. Cable bracket        |
| 32. Actuator switch     | 46. Back cover                 | B. Cable connector      |
| 33. Washers             | 54. Ferrule nut                | C. Multiplier connector |
| 34. Screws              | 57. Screws                     | D. Ribbed slots         |
| 40. Screws              |                                |                         |

## Isocore® Fluid Supply Hose Replacement

Follow these steps to remove, examine, and replace the 1/4-in. ID Isocore fluid hose. Refer to *Fluid Tube Replacement* on page 7-25 if your spray gun uses the 3/8-in. OD fluid tube.

1. Turn off the gun control unit and ground the spray gun electrode to remove any residual charge.
2. Turn off the fluid-delivery system and relieve the fluid pressure.

3. See Figure 7-11. Loosen the fluid hose collar nut (B) and remove the fluid hose from the cable bracket (A).
4. Loosen the hose retaining nut (C), which is located at the extension fluid inlet boss (D), and unscrew it completely.
5. Pull the hose assembly (17) out of the spray gun extension.
6. Clean the hose fittings.
7. Inspect the O-ring (12) on the gun end fitting. Replace if necessary.
8. Lubricate the O-ring with dielectric grease.
9. Push the end fitting into the extension fluid inlet boss (D).
10. Apply a liberal coat of dielectric grease to the threads of the retaining nut (C) and screw the retaining nut into the extension and tighten  $\frac{1}{4}$  turn past hand tight. Do not overtighten.
11. Install the fluid hose assembly (17) into the cable bracket (A).
12. Install the two screws (57) in the hose flange to secure the fluid hose to the cable bracket.

**NOTE:** The effectiveness of the electrostatics may diminish when coating resistivities fall below 0.25 megohm. Refer to page 3-5 and see Figure 3-3 to review the relationship between coating conductivity and fluid tube/hose length and ID.

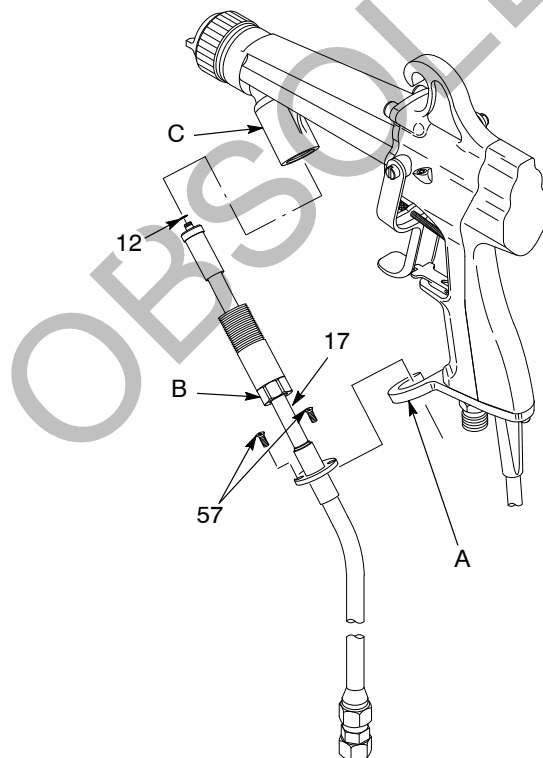

Figure 7-11 Isocore Fluid Supply Hose Replacement

- |                         |                               |
|-------------------------|-------------------------------|
| 12. O-ring              | A. Cable bracket              |
| 17. Fluid hose assembly | B. Retaining nut              |
| 57. Screws              | C. Extension fluid inlet boss |

## Fluid Tube Replacement

Follow these steps to remove, examine, and replace the  $\frac{3}{8}$ -in. OD fluid tube. Refer to *Isocore Fluid Supply Hose Replacement* on page 7-23 if your spray gun uses the  $\frac{1}{4}$ -in. OD fluid hose.

1. Turn off the gun control unit and ground the spray gun electrode to remove any residual charge.
2. Turn off the fluid-delivery system and relieve the fluid pressure.
3. See Figure 7-12. Remove the two screws (57) that attach the fluid tube elbow (58) to the cable bracket (A) and remove the fluid tube from the bracket.
4. Loosen the tube retaining nut (56), which is located at the extension fluid inlet boss (B), and unscrew it completely.
5. Pull the tube (17) out of the spray gun extension.
6. Loosen the ferrule nut (54) and remove the fluid tube from the elbow.

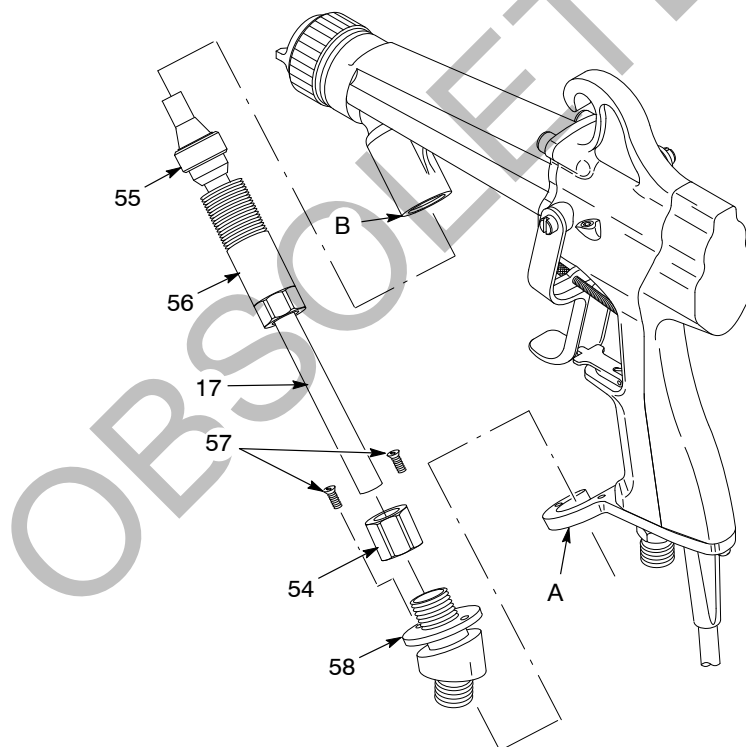

Figure 7-12 Fluid Tube Replacement

- |                   |                               |
|-------------------|-------------------------------|
| 17. Tube          | 57. Screws                    |
| 54. Ferrule nut   | 58. Elbow                     |
| 55. Ferrule       | A. Cable bracket              |
| 56. Retaining nut | B. Extension fluid inlet boss |

7. Inspect the ferrule (55) and fluid tube (17) and replace them if damaged or leaking.
8. Slide the ferrule over the fluid tube leaving  $\frac{1}{2}$  in. of the tube exposed on

one end.

9. Slide the retaining nut (56) then the ferrule nut (54) over the other end of the tube.
10. Insert and push the fluid tube, ferrule end first, into the extension fluid inlet boss (B).
11. Tighten the retaining nut (56) with a wrench approximately  $\frac{1}{4}$ - $\frac{1}{2}$  turn past hand tight.
12. Slide the elbow (58) over the fluid tube and push the elbow into the cable bracket (A)
13. Secure the elbow to the cable bracket with the screws (57).
14. Tighten the ferrule nut onto the elbow with a wrench approximately  $\frac{1}{4}$ - $\frac{1}{2}$  turn past hand tight.
15. Leak test the fittings. If either end leaks, the ferrule nut and retaining nut can be tightened further.
16. Turn on the fluid-delivery system. Refer to the appropriate fluid-delivery system manual.
17. Turn on the gun control unit.

OBSOLETE



# Service Illustrations and Notes

## Air Spray and KVL<sup>P</sup> Spray Gun with 1/4-in. ID Fluid Hose

Use Figure 7-13 and Table 7-1 when repairing the spray gun.

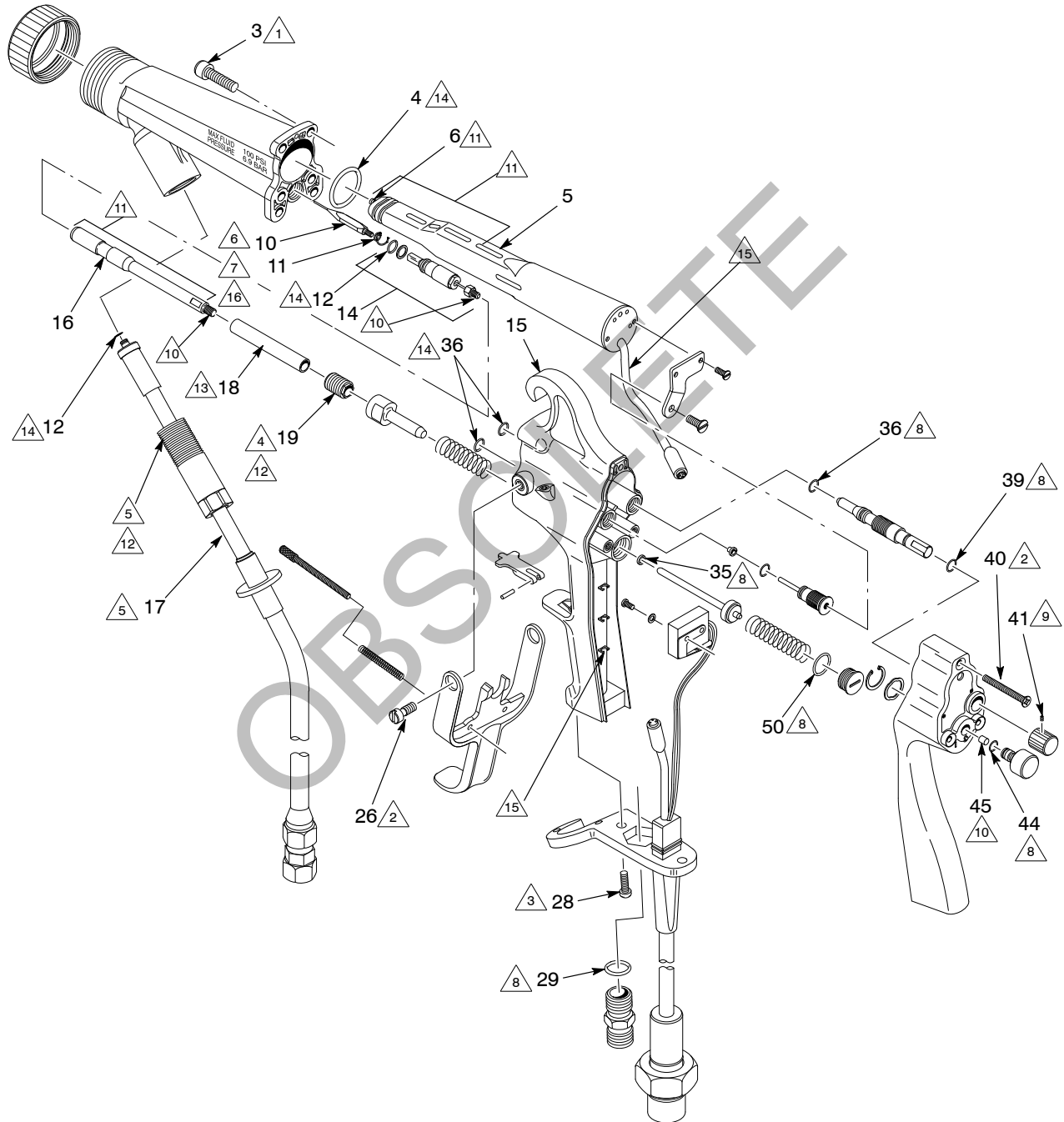

















Figure 7-13 Spray Gun with 1/4-in. ID Fluid Hose Service Notes

Table 7-1 Spray Gun with 1/4-in. ID Fluid Hose Service Notes

Note	Item	Description
	3	Tighten to 2.27–2.83 N•m (20–25 in.-lb).
	26, 40	Tighten to 0.9–1.13 N•m (8–10 in.-lb).
	28	Tighten to 1.36–1.69 N•m (12–15 in.-lb).
	19	Tighten hand tight.
	17	Tighten the hose assembly into the extension inlet 1/4 turn past hand tight.
	10	Trigger the spray gun to pull the needle tip back before removing or installing a fluid tip.
	10	Tighten finger tight.
	12, 21, 29, 35, 36, 39, 44, 50 14 (wire at both ends) 15 (inside the fluid return bore) 16 (end of pull shaft), 19 (inside of packing cartridge retainer) 20 (the small outside diameter)	Generously apply MagnaLube G (PTFE-filled lubricant) to these parts.
	41	Align the set screw with the flat on the the knob.
	14, 16, 45	Apply threadlocking adhesive to the threads of these items.
	5, 6, 16	Apply a liberal coat of dielectric grease to these areas.
	17, 19	Apply a thin coat of dielectric grease to the threads of these items.
	18	Apply a thin coat of dielectric grease to the outside of this item.
	4, 12, 36	Apply dielectric grease to these O-rings.
	5, 15	Make sure the cable is snapped into the ribbed slots in the back of the handle. Do not pinch the cable between the handle and the back cover.
	10	A removeable threadlocking adhesive can be applied to the threads of the needle if there are problems with the needle backing out.

# Air Spray and KVLV Spray Gun with 3/8-in. OD Fluid Tube

Use Figure 7-14 and Table 7-2 when repairing the spray gun.

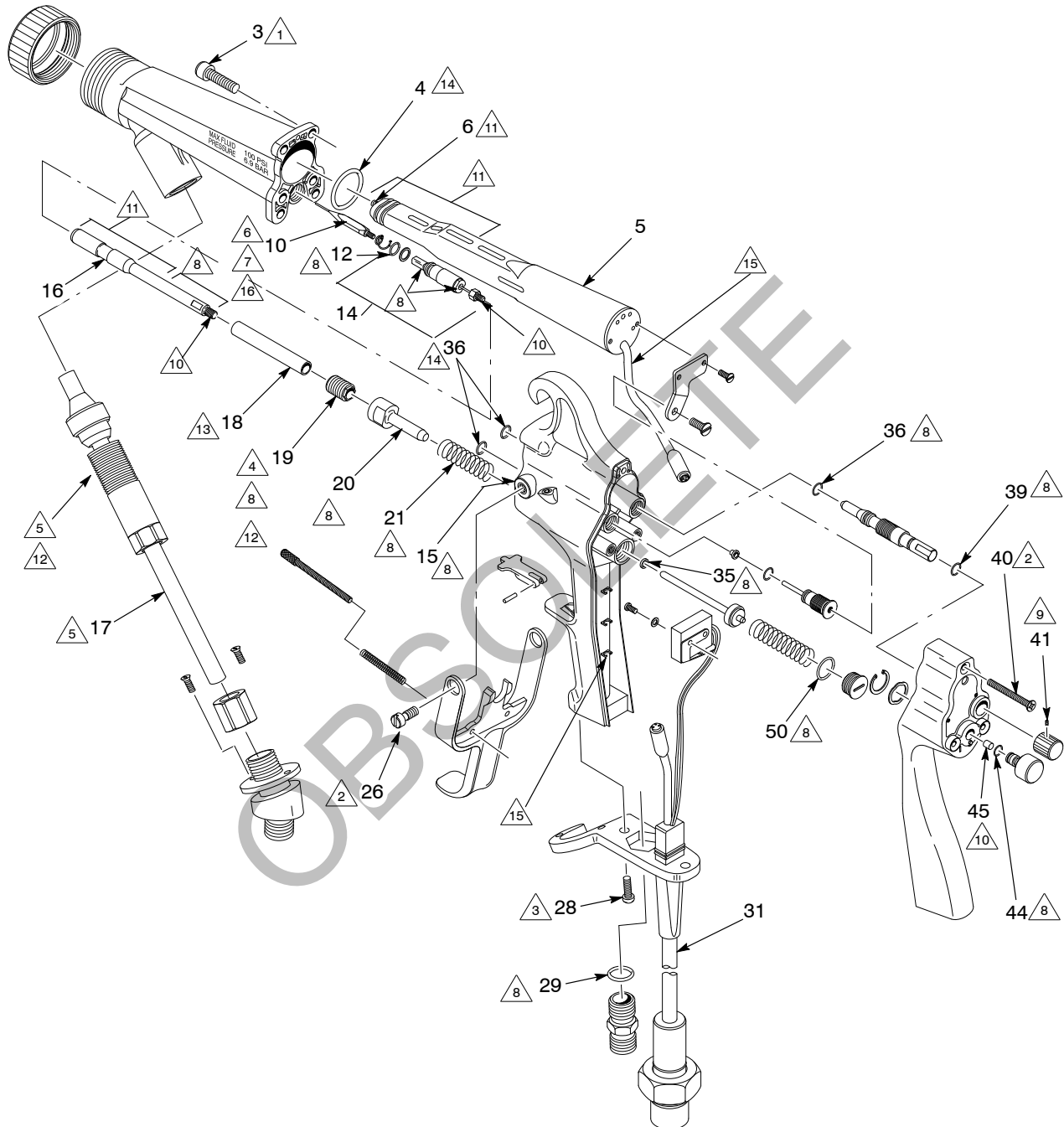

















Figure 7-14 Spray Gun with 3/8-in OD Fluid Tube Service Notes

Table 7-2 Spray Gun with  $\frac{3}{8}$ -in OD Fluid Tube Service Notes

Note	Item	Description
	3	Tighten to 2.27–2.83 N•m (20–25 in.-lb).
	26, 40	Tighten to 0.9–1.13 N•m (8–10 in.-lb).
	28	Tighten to 1.36–1.69 N•m (12–15 in.-lb).
	19	Tighten hand tight.
	17	Tighten the hose assembly into the extension inlet $\frac{1}{4}$ turn past hand tight.
	10	Trigger the spray gun to pull the needle tip back before removing or installing a fluid tip.
	10	Tighten finger tight.
	12, 21, 29, 35, 36, 39, 44, 50 14 (wire at both ends) 15 (inside the fluid return bore) 16 (end of pull shaft), 19 (inside of packing cartridge retainer) 20 (the small outside diameter)	Generously apply MagnaLube G (PTFE-filled lubricant) to these parts..
	41	Align the set screw with the flat on the the knob.
	14, 16, 45	Apply threadlocking adhesive to the threads of these items.
	5, 6, 16	Apply a liberal coat of dielectric grease to these areas.
	17, 19	Apply a thin coat of dielectric grease to the threads of this item.
	18	Apply a thin coat of dielectric grease to the outside of this item.
	4, 36	Apply dielectric grease to these O-rings.
	5, 15	Make sure the cable is snapped into the ribbed slots in the back of the spray gun's handle. Do not pinch the cable between the handle and the back cover.
	10	A removable thread-locking adhesive can be applied to the threads of the needle if there are problems with the needle backing out.

OBSOLETE

## Section 8

# Parts

### Introduction

To order parts, call the Nordson Finishing Customer Support Center at (800) 433-9319 or contact your local Nordson representative. Use the parts lists and accompanying illustrations to locate and describe parts correctly.

### Using the Illustrated Parts List

Numbers in the Item column correspond to numbers that identify parts in illustrations following each parts list. The code NS (not shown) indicates that a listed part is not illustrated. A dash (—) is used when the part number applies to all parts in the illustration.

The number in the Part column is the Nordson Corporation part number. A series of dashes in this column (-----) means the part cannot be ordered separately.

The Description column gives the part name, as well as its dimensions and other characteristics when appropriate. Indentions show the relationships between assemblies, subassemblies, and parts.

- If you order the assembly, items 1 and 2 will be included.
- If you order item 1, item 2 will be included.
- If you order item 2, you will receive item 2 only.

The number in the Quantity column is the quantity required per unit, assembly, or subassembly. The code AR (As Required) is used if the part number is a bulk item ordered in quantities or if the quantity per assembly depends on the product version or model.

Letters in the Note column refer to notes at the end of each parts list. Notes contain important information about usage and ordering. Special attention should be given to notes.

Item	Part	Description	Quantity	Note
—	0000000	Assembly	1	
1	000000	• Subassembly	2	A
2	000000	• • Part	1	

## Spray Gun Parts

**NOTE:** Before ordering parts for your spray gun, review the appropriate procedure in the *Repair* section to make sure you are ordering the correct parts, lubricant, and adhesives to complete the procedure.

### *Air Spray and KVLP Spray Gun with 1/4-in. ID Fluid Hose*

See Figure 8-1.

Item	Part	Description	Quantity	Note
—	336715	SPRAY GUN, Kinetix, air spray/KVLP, low pressure, manual, electrostatic, 50 ft	1	
1	325547	• RING, retaining, air cap	1	
2	336644	• EXTENSION, machined, electrostatic	1	
3	325752	• SCREW, socket, #10–24 x 0.625 in., stainless steel, A-286	4	
4	336499	• O-RING, PTFE, 1.05 x 0.07 in.	1	A
5	336505	• MULTIPLIER, 93 kV, Kinetix	1	
6	336383	• • SPRING ASSEMBLY, contact	1	
7	336375	• BRACKET, heat sink, manual, electrostatic	1	
8	981522	• SCREW, pan, #4–40 x 0.125 in., slot, zinc	2	
9	982763	• MACHINE SCREW, pan, #8–32 x 0.375 in., steel, zinc	1	
10	-----	• NEEDLE WITH RESISTOR, machined	1	B
11	336549	• SPRING, contact, KVLP, Kinetix	1	B
12	336677	• O-RING, Perlast, 0.25 x 0.375 x 0.063 in.	2	C, D
13	105527	• SERVICE KIT, ring, backup, quantity 4	1	D
14	-----	• CARTRIDGE ASSEMBLY, packing	1	D
15	336380	• HANDLE, machined, Kinetix	1	
16	336638	• SHAFT WITH STUD, packing cartridge, Kinetix	1	
17	-----	• HOSE, Kinetix, low pressure, standard, 1/4-in. ID, manual, 8 ft	1	E
18	325748	• RETAINER, sleeve, packing cartridge	1	
19	325749	• RETAINER, packing cartridge, electrostatic	1	
20	325751	• PULLER, shaft, trigger, electrostatic	1	
21	325534	• SPRING, fluid return, low pressure	1	
22	-----	• LOCK, trigger, Kinetix	1	F
23	985438	• PIN, dowel, 0.094 x 0.438 in., alloy steel, hardened and ground	1	F
24	336350	• SCREW, adjustment, #6–32 x 1.5 in.	1	
25	336353	• SPRING, compression, fluid adjustment	1	

NOTE A: Included in air seal service kit 336634. Refer to *Air Seal* on page 8-10.

B: Included in needle service kit 336556. Refer to *Needle with Resistor* on page 8-11.

C: Included in Perlast fluid seal service kit 336679. Refer to *Perlast Fluid Seal* on page 8-10.

D: Included in packing cartridge service kit 1089861. Refer to *Packing Cartridge* on page 8-10.

E: Refer to *Hoses and Couplings* on page 8-12.

F: Included in trigger lock service kit 336631. Refer to *Electrostatic Trigger Lock* on page 8-11.

*Continued...*

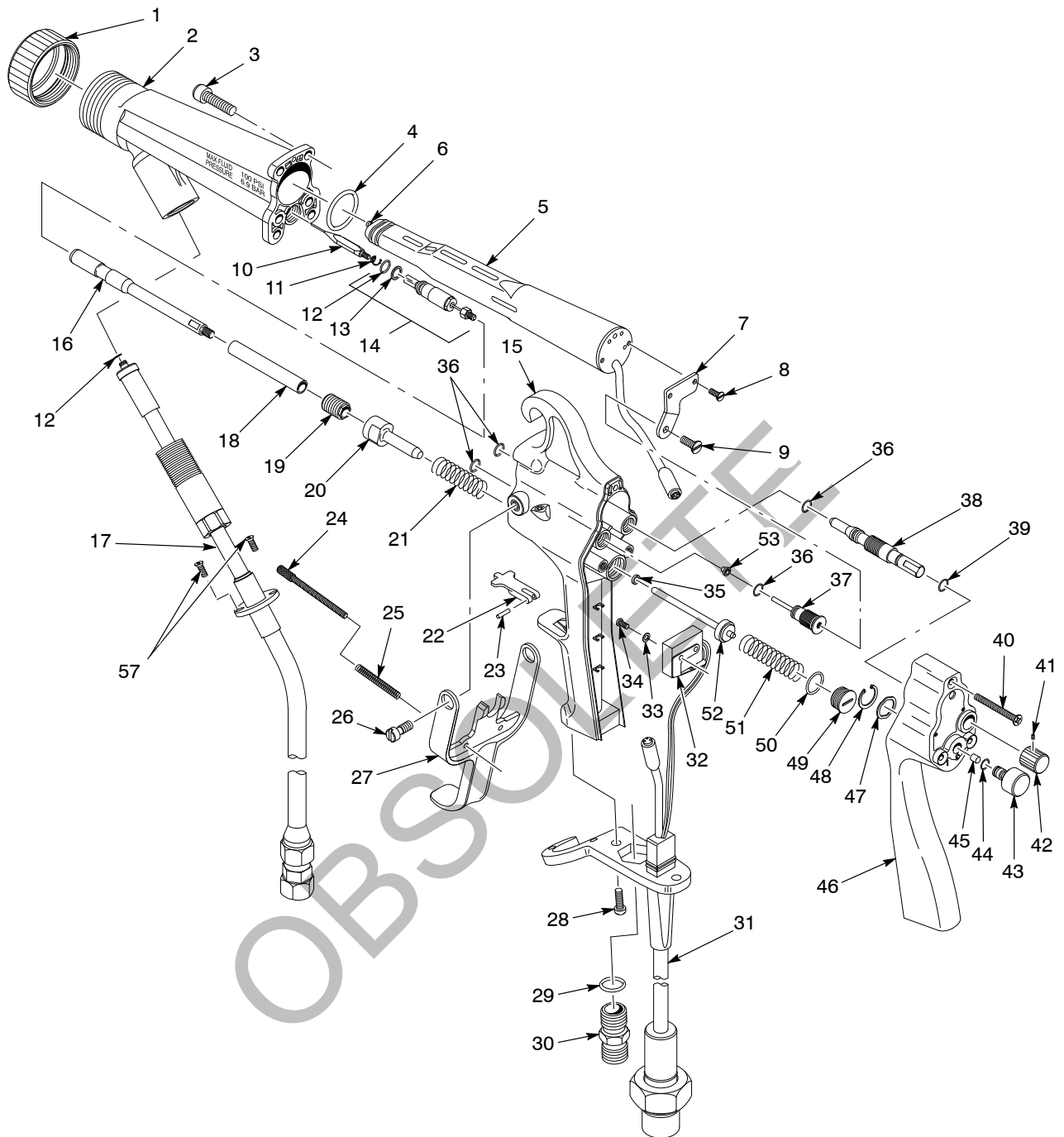

Figure 8-1 Air Spray and KVLP Manual Electrostatic Spray Gun with 1/4-in. ID Fluid Hose



**Air Spray and KVL P Spray Gun with 1/4-in. ID Fluid Hose (contd)**

Item	Part	Description	Quantity	Note
26	246526	• SCREW, pivot, trigger/handle	2	
27	336365	• TRIGGER, Kinetix	1	
28	325754	• SCREW, cross recess, pan, #8-32 x 0.406 in., stainless steel, A-286	2	
29	940130	• O-RING, hotpaint, 0.438 x 0.563 x 0.063 in.	1	A
30	973505	• COUPLING, 1/4 x 1/4 in., brass	1	
31	336462	• CABLE, Kinetix, manual, 50 ft, 5 conductor	1	
32	132336	• ACTUATOR SWITCH	1	
33	983113	• LOCK WASHER, split, 2, steel, zinc	2	
34	981915	• SCREW, pan head, #2-56 x 0.375 in., slot, zinc	2	
35	955076	• SEAL, 1/8 x 1/4 x 1/16 in., PTFE	1	G
36	940110	• O-RING, hotpaint, 0.313 x 0.438 x 0.063 in.	4	A
37	336376	• HEAT SINK, electrostatic	1	
38	336334	• VALVE, air adjust, electrostatic	1	
39	336512	• O-RING, PTFE, 0.313 x 0.438 x 0.063 in., special	1	A
40	325760	• SCREW, cross recess, flat, #8-32 x 1.375 in., #18-8 stainless steel	3	
41	981030	• SCREW, socket set, #6-32 x 0.187 in., dog, zinc	1	
42	325533	• KNOB, valve, adjustment	1	
43	336377	• KNOB, on/off, switch, electrostatic	1	
44	940090	• O-RING, Viton, 0.208-in. ID x 0.07-in. wide, brown	1	A
45	336378	• PIN, knob, on/off, electrostatic	1	
46	336411	• COVER, electrostatic, molded	1	
47	325755	• WASHER, curved spring, 0.49 x 0.331 in.	1	
48	986030	• RETAINING RING, external, 31, basic	1	
49	1090742	• PLUG, valve, air trigger, 0.688 in. dia. head	1	
50	940140	• O-RING, hotpaint, 0.50 x 0.625 x 0.063 in.	1	A
51	325499	• SPRING, air valve	1	G
52	325523	• STEM, air valve, trigger assembly	1	G
53	336427	• PLUG, air adjust, KVL P, electrostatic	1	
57	346725	• MACHINE SCREW, flathead x recess, 4-40, 0.25 in. stainless steel	2	
NS	901905	• BRUSH (wooden toothbrush type)	1	
NS	247066	• BRUSH	1	
NS	336642	• WRENCH, Kinetix, combination tool	1	
NS	227583	• BAG, cover, Kinetix	3	H
NS	1028630	• PLIERS, needle nose bent, Kinetix	1	
NS	1028631	• TOOL, needle, Kinetix	1	

NOTE A: Included in air seal service kit 336634. Refer to *Air Seal* on page 8-10.  
G: Included in air valve service kit 325657. Refer to *Air Valve* on page 8-10.  
H: Order 227584 for a quantity of 12 cover bags.  
NS: Not Shown

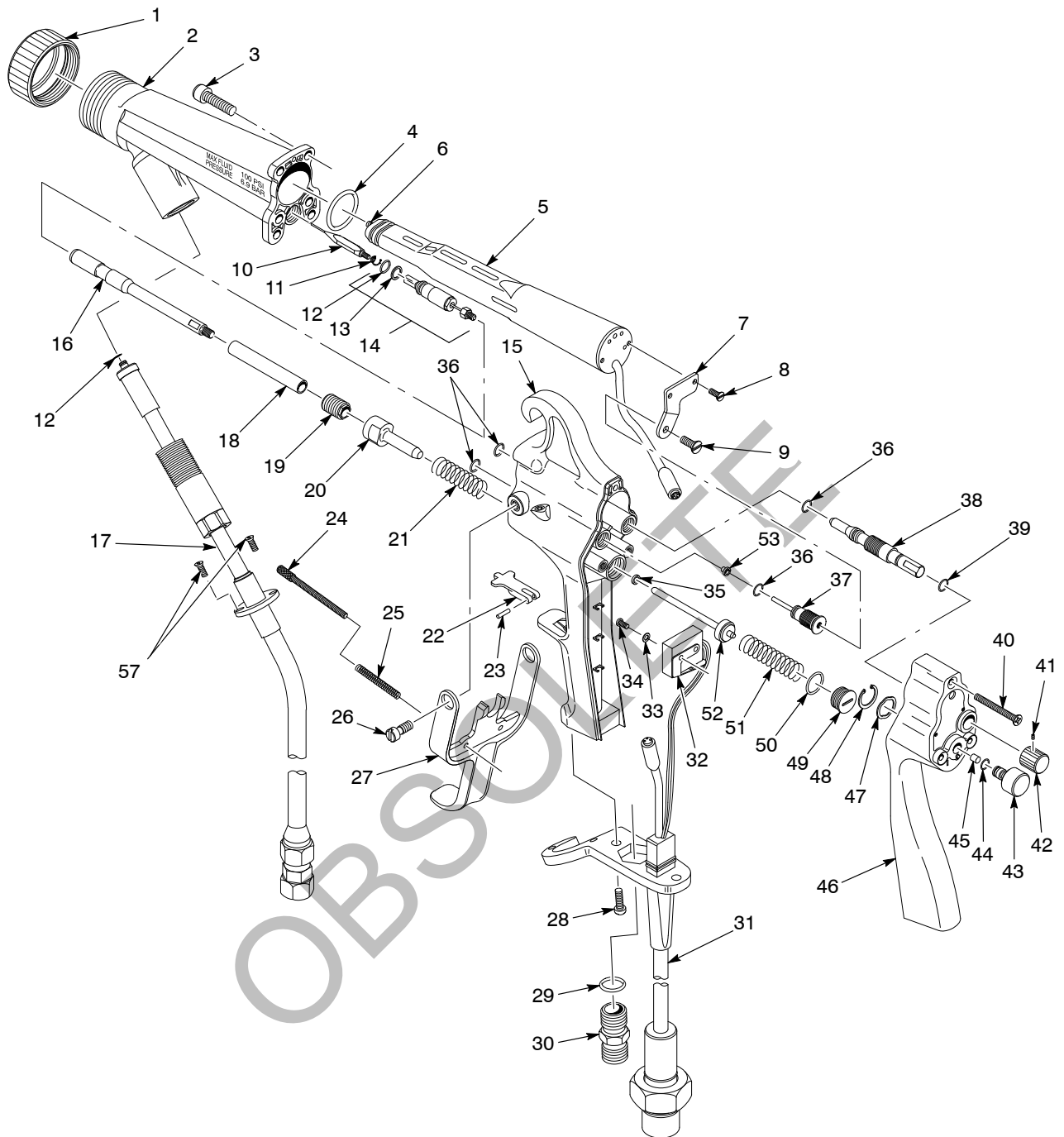

Figure 8-1 Air Spray and KVLP Manual Electrostatic Spray Gun with 1/4-in. ID Fluid Hose

## Air Spray and KVLP Spray Gun with $\frac{3}{8}$ -in. OD Fluid Tube

See Figure 8-2.

Item	Part	Description	Quantity	Note
—	336724	SPRAY GUN, Kinetix, $\frac{3}{8}$ -in. NPS, low pressure, manual, electrostatic, 50 ft	1	
1	325547	• RING, retaining, air cap	1	
2	336644	• EXTENSION, machined, electrostatic	1	
3	325752	• SCREW, socket, #10–24 x 0.625 in., stainless steel, A-286	4	
4	336499	• O-RING, PTFE, 1.05 x 0.07 in.	1	A
5	336505	• MULTIPLIER, 93 kV, Kinetix	1	
6	336383	• • SPRING ASSEMBLY, contact	1	
7	336375	• BRACKET, heat sink, manual, electrostatic	1	
8	981522	• SCREW, pan, #4–40 x 0.125 in., slot, zinc	2	
9	982763	• MACHINE SCREW, pan, #8–32 x 0.375 in., steel, zinc	1	
10	-----	• NEEDLE WITH RESISTOR, machined	1	B
11	336549	• SPRING, contact, KVLP, Kinetix	1	B
12	336677	• O-RING, Perlast, 0.25 x 0.375 x 0.063 in.	2	C, D
13	105527	• SERVICE KIT, ring, backup, quantity 4	1	D
14	-----	• CARTRIDGE ASSEMBLY, packing	1	D
15	336380	• HANDLE, machined, Kinetix	1	
16	336638	• SHAFT WITH STUD, packing cartridge, Kinetix	1	
17	336468	• TUBE, PTFE, $\frac{3}{8}$ -in. OD x $\frac{3}{32}$ -in. ID x 0.141-in. wall	1	E
18	325748	• RETAINER, sleeve, packing cartridge	1	
19	325749	• RETAINER, packing cartridge, electrostatic	1	
20	325751	• PULLER, shaft, trigger, electrostatic	1	
21	325534	• SPRING, fluid return, low pressure	1	
22	-----	• LOCK, trigger, Kinetix	1	F
23	985438	• PIN, dowel, 0.094 x 0.438 in., alloy steel, hardened and ground	1	F
24	336350	• SCREW, adjustment, #6–32 x 1.5 in.	1	
25	336353	• SPRING, compression, fluid adjustment	1	
26	246526	• SCREW, pivot, trigger/handle	2	
27	336365	• TRIGGER, Kinetix	1	
28	325754	• SCREW, cross recess, pan, #8–32 x 0.406 in., stainless steel, A-286	2	
29	940130	• O-RING, hotpaint, 0.438 x 0.563 x 0.063 in.	1	A
30	973505	• COUPLING, $\frac{1}{4}$ x $\frac{1}{4}$ in., brass	1	

NOTE A: Part is included in air seal service kit 336634. Refer to *Air Seal* on page 8-10.

B: Part is included in needle service kit 336556. Refer to *Needle with Resistor* on page 8-11.

C: Part is included in Perlast fluid seal service kit 336679. Refer to *Perlast Fluid Seal* on page 8-10.

D: Part is included in packing cartridge service kit 1089861. Refer to *Packing Cartridge* on page 8-10.

E: Refer to *Hoses and Couplings* on page 8-12.

F: Part is included in trigger lock service kit 336631. Refer to *Electrostatic Trigger Lock* on page 8-11.

Continued...

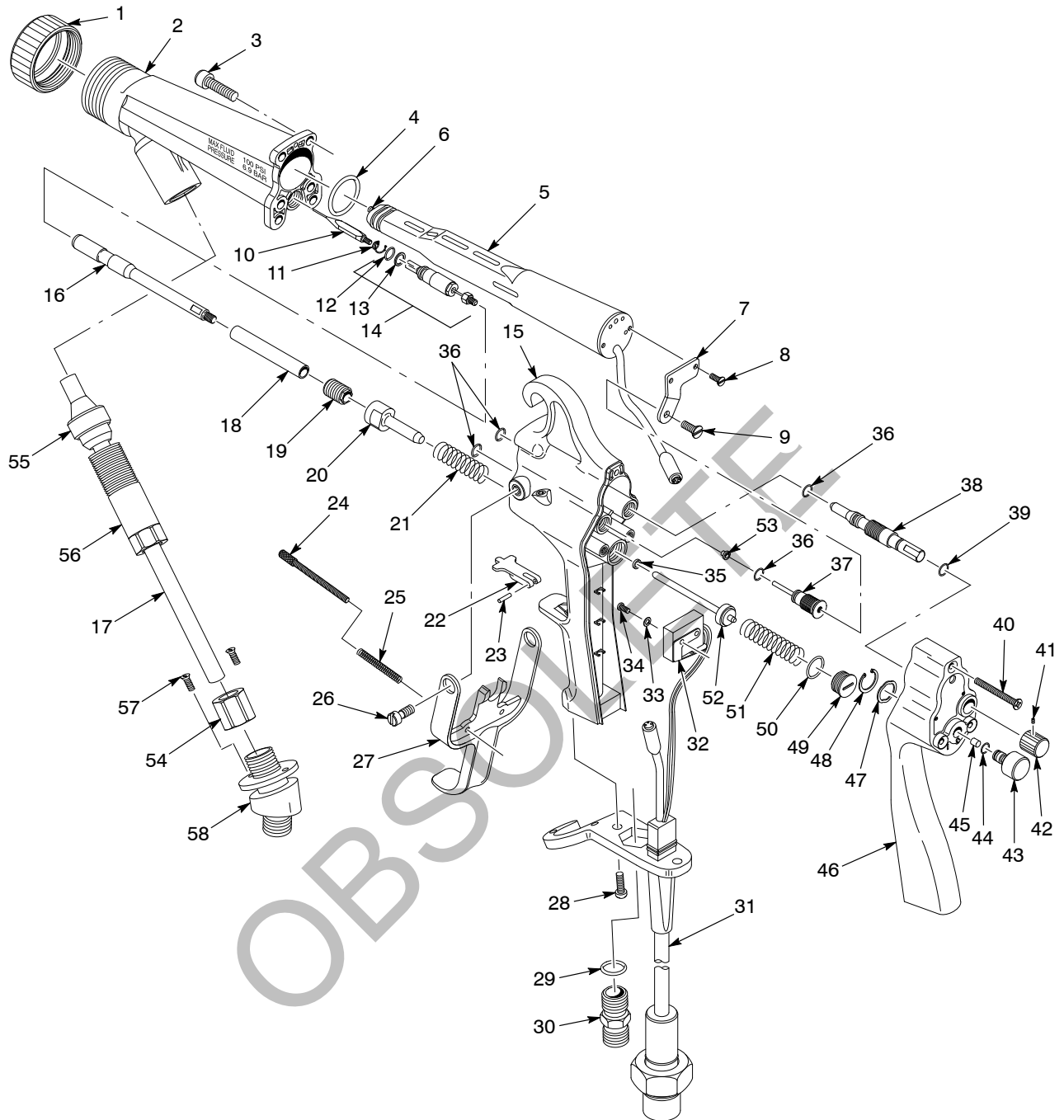

Figure 8-2 Air Spray and KVLP Manual Electrostatic Spray Gun with  $\frac{3}{8}$ -in. OD Fluid Tube

**Air Spray and KVLP Spray Gun with  $\frac{3}{8}$ -in. OD Fluid Tube** (contd)

Item	Part	Description	Quantity	Note
31	336462	• CABLE, Kinetix, manual, 50 ft, 5 conductor	1	
32	132336	• ACTUATOR SWITCH	1	
33	983113	• LOCK WASHER, split, 2, steel, zinc	2	
34	981915	• SCREW, pan, #2-56 x 0.375 in., slotted, zinc	2	
35	955076	• SEAL, $\frac{1}{8}$ x $\frac{1}{4}$ x $\frac{1}{16}$ in., PTFE	1	G
36	940110	• O-RING, hotpaint, 0.313 x 0.438 x 0.063 in.	4	A
37	336376	• HEAT SINK, electrostatic	1	
38	336334	• VALVE, air adjust, electrostatic	1	
39	336512	• O-RING, PTFE, 0.313 x 0.438 x 0.063 in., special	1	A
40	325760	• SCREW, cross recess, flat, #8-32 x 1.375 in., #18-8 stainless steel	3	
41	981030	• SCREW, socket, #6-32 x 0.187 in., dog, zinc	1	
42	325533	• KNOB, valve, adjustment	1	
43	336377	• KNOB, on/off, switch, electrostatic	1	
44	940090	• O-RING, Viton, 0.208 ID x 0.07 wide, brown	1	A
45	336378	• PIN, knob, on/off, electrostatic	1	
46	336411	• COVER, electrostatic, molded	1	
47	325755	• WASHER, curved spring, 0.49 x 0.331 in.	1	
48	986030	• RETAINING, ring, external, 31, basic	1	
49	325498	• PLUG, valve, air trigger	1	
50	940140	• O-RING, hotpaint, 0.50 x 0.625 x 0.063 in.	1	A
51	325499	• SPRING, air valve	1	G
52	325523	• STEM, air valve, trigger assembly	1	G
53	336427	• PLUG, air adjust, KVLP, electrostatic	1	
54	971456	• NUT, ferrule, $\frac{3}{8}$ -in. tube, nylon, plastic grip	1	
55	336752	• FERRULE, $\frac{3}{8}$ -in. tube, low pressure, hose, electrostatic	1	
56	336347	• RETAINER, fluid hose	1	
57	346725	• MACHINE SCREW, flathead x recess, 4-40, 0.25 in. stainless steel	2	
58	336477	• ELBOW, $\frac{3}{8}$ -in. NPSM x $\frac{5}{8}$ -20 UN-2A	1	
NS	901905	• BRUSH (wooden toothbrush type)	1	
NS	247066	• BRUSH	1	
NS	336642	• WRENCH, Kinetix, combination tool	1	
NS	227583	• BAG, cover, Kinetix	3	H
NS	1028630	• PLIERS, needle nose bent, Kinetix	1	
NS	1028631	• TOOL, needle, Kinetix	1	

NOTE A: Part is included in air seal service kit 336634. Refer to *Air Seal* on page 8-10.

G: Part is included in air valve service kit 325657. Refer to *Air Valve* on page 8-10.

H: Order part 227584 for a quantity of 12 cover bags.

NS: Not Shown

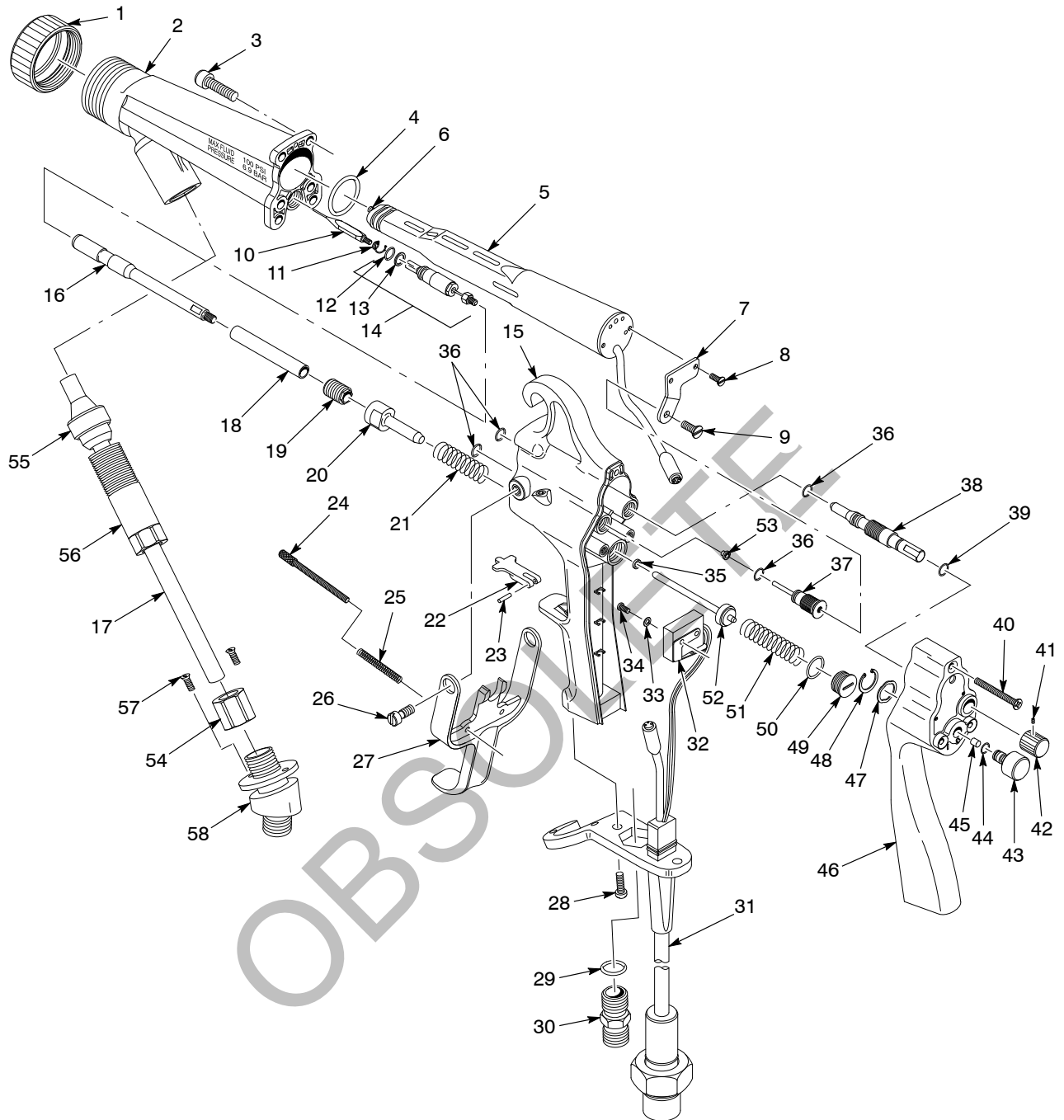

Figure 8-2 Air Spray and KVLP Manual Electrostatic Spray Gun with  $\frac{3}{8}$ -in. OD Fluid Tube

## Recommended Kits

See Figure 8-1 or 8-2.

### Perlast Fluid Seal

Item	Part	Description	Quantity	Note
—	336679	PERLAST FLUID SEAL KIT, gun, Kinetix	1	
12	336677	• O-RING, Perlast, 0.25 x 0.375 x 0.063 in.	2	A
NS	336678	• O-RING, Perlast, 0.375 x 0.50 x 0.063 in.	1	B, C
NS	336569	• BACKUP RING, conductive, 0.39-in ID x 0.045-in. thick, cut	1	B
NOTE A: Used on the packing cartridge and fluid hose. B: Used on the fluid tips. C: Lubricate with dielectric grease. NS: Not Shown				

### Air Seal

Item	Part	Description	Quantity	Note
—	336634	AIR SEAL KIT, hotpaint, electrostatic	1	
4	336499	• O-RING, PTFE, 1.05 x 0.070 in.	1	
29	940130	• O-RING, hotpaint, 0.438 x 0.563 x 0.063 in.	1	
36	940110	• O-RING, hotpaint, 0.313 x 0.438 x 0.063 in.	4	
39	336512	• O-RING, PTFE, 0.313 x 0.438 x 0.063 in., special	1	
44	940090	• O-RING, Viton, 0.208 ID x 0.07-in. wide, brown	1	
50	940140	• O-RING, hotpaint, 0.50 x 0.625 x 0.063 in.	1	

### Air Valve

Item	Part	Description	Quantity	Note
—	325657	AIR VALVE KIT	1	
35	955076	• SEAL, $\frac{1}{8} \times \frac{1}{4} \times \frac{1}{16}$ in., PTFE	1	
51	325499	• SPRING, air valve	1	
52	325523	• STEM, air valve, trigger assembly	1	

### Packing Cartridge

The Kinetix spray gun is shipped with the standard gold packing cartridge, which is appropriate for most coating materials. Use the optional PTFE packing cartridge, part 1089862, with harsh chemical solvents such as MEK.

Item	Part	Description	Quantity	Note
—	1089861	PACKING CARTRIDGE KIT, gold, Kinetix	1	
12	336677	• O-RING, Perlast, 0.25 x 0.375 x 0.063 in.	1	
13	-----	• BACKUP RING, single, $\frac{1}{4} \times \frac{3}{8}$ in.	1	
14	-----	• CARTRIDGE ASSEMBLY, packing	1	

## Trigger Lock

Item	Part	Description	Quantity	Note
—	336631	TRIGGER LOCK KIT, electrostatic	1	
22	-----	• LOCK, trigger, Kinetix	1	
23	985438	• PIN, dowel, 0.094 x 0.438 in., alloy steel, hardened and ground	1	

## Needle with Resistor

Item	Part	Description	Quantity	Note
—	336556	NEEDLE WITH RESISTOR KIT, electrostatic	1	
10	-----	• NEEDLE WITH RESISTOR, machined	1	
11	336549	• SPRING, contact, KVLP, Kinetix	1	

## Optional Hotpaint Fluid Seal

The standard fluid seal O-rings for all Kinetix products provide solvent resistance. If a particular application does not require solvent resistance then the hotpaint seal kit can be used instead. These O-rings should not be used with highly polar solvents like Acetone and MEK, Chlorinated Hydrocarbons and Nitro Hydrocarbons unless they will be replaced regularly.

Part	Description	Quantity	Note
336633	HOTPAINT FLUID SEAL KIT, electrostatic	1	
940100	• O-RING, hotpaint, 0.25 x 0.375 x 0.063 in.	2	A
940120	• O-RING, hotpaint, 0.375 x 0.50 x 0.063 in.	1	B
336569	• BACKUP RING, conductive, 0.39-in. ID x 0.045-in. thick, cut	1	B

NOTE A: Used on the packing cartridge and fluid hose.  
B: Used on the fluid tips.

## Optional PTFE Packing Cartridge

Use the PTFE packing cartridge with harsh chemical solvents such as MEK.

Part	Description	Note
1089862	KIT, cartridge, packing, Kinetix, electrostatic, PTFE	
-----	• CARTRIDGE ASSEMBLY, packing, electrostatic	
-----	• BACKUP RING, single, 1/4 x 3/8 in.	
336677	• O-RING, Perlast, 0.25 x 0.375 x 0.063 in.	



## Optional Hoses and Couplings

Hoses and couplings must be ordered separately.

Part	Description	Quantity	Note
336359	25-FT HOSE KIT, Kinetix, low pressure, 1/4-in. ID, manual	1	
336357	8-FT HOSE KIT, Kinetix, low pressure, 1/4-in. ID, standard, electrostatic	1	A
1074586	HOSE, Kinetix, 8 ft., solvent resistant, manual	1	B
1074587	HOSE, Kinetix, 25 ft., solvent resistant, manual	1	B
336460	TUBE & FERRULE KIT, gun, 3/8-in. OD x 3/32-in. ID x 0.141-in. wall, low pressure, manual	1	C
336752	• FERRULE, 3/8-in. tube, low pressure, hose, electrostatic	1	
336347	• RETAINER, fluid hose	1	
336468	• TUBE, PTFE, 3/8-in. OD x 3/32-in. ID x 0.141-in. wall	1	
971456	• NUT, ferrule, 3/8-in. tube, N, w/p grip	1	
336477	• ELBOW, 3/8-in. NPSM x 5/8-20 UN-2A	1	
346725	• MACHINE SCREW, flathead x recess, 4-40, 0.250 in., stainless steel	2	
1074130	30-FT HOSE, air, with fittings	1	
-----	• FITTING, barb, 1/4-in. NPSF x 3/8-in. hose	2	
-----	• HOSE, air, 3/8-in. ID	1	
-----	• CLAMP, hose	2	
1074131	50-FT HOSE, air, with fittings	1	
-----	• FITTING, barb, 1/4-in. NPSF x 3/8-in. hose	2	
-----	• HOSE, air, 3/8-in. ID	1	
-----	• CLAMP, hose	2	
1074132	100-FT HOSE, air, with fittings	1	
-----	• FITTING, barb, 1/4-in. NPSF x 3/8-in. hose	2	
-----	• HOSE, air, 3/8-in. ID	1	
-----	• CLAMP, hose	2	
176546	25-FT HOSE, air, with fittings	1	
-----	• FITTING, barb, 5/16 x 1/4-in. NPSM	2	
-----	• HOSE, 5/16 in., PVC core TPU cover	1	
184367	• CLAMP, hose	2	
336470	COUPLING, 3/8-in. NPSM x 3/8-in. NPSM, brass	1	
972637	COUPLING, 3/8-in. NPSM x 3/8-in. NPSM, brass, nickel plate	1	
336497	STEM, swivel, 3/8-in. NPS, HOSCO	1	D
336495	CONNECTOR, QD, 3/8-in. NPS, HOSCO	1	D
336496	RESTRICTOR, circ, 3/8-in. NPS, PLH-RY-6	1	D
1031047	ISOCOIL ASSEMBLY, 0.250-in. OD x 0.094-in. wall, 24.5 in.	1	E
NOTE A: This hose is included with spray gun 336715.			
B: These hoses are optional and should be used only in applications in which M.E.K. or other harsh solvents are present.			
C: Spray gun 336724 comes standard with 3/8-in. OD tube 336468, which is included in this kit.			
D: Use these parts with spray gun 336724, or with tube and ferrule kit 336460.			
E: To install the Isocoil assembly on spray gun 336715, order elbow 336477. This elbow is not included with the spray gun and must be ordered separately. The elbow is included with spray gun 336724.			

## Recommended Spare Parts

Keep the following parts in inventory to avoid unplanned downtime. Quantities listed support a single spray gun. Adjust order quantities based on the number of spray guns in service.

Part	Description	Quantity	Note
336679	PERLAST FLUID SEAL KIT, gun, Kinetix	1	A
336633	HOTPAINT FLUID SEAL KIT, electrostatic	1	A
336634	AIR SEAL KIT, hotpaint, electrostatic	1	
325657	AIR VALVE KIT	1	
1089861	PACKING CARTRIDGE KIT, gold, Kinetix	1	B
1089862	PACKING CARTRIDGE KIT, PTFE, Kinetix	1	B
336631	TRIGGER LOCK KIT, electrostatic	1	
336462	50-FT CABLE, Kinetix, manual, 5 conductor, standard	1	
336466	100-FT CABLE, Kinetix, manual, 5 conductor, optional	1	
336556	NEEDLE WITH RESISTOR KIT, electrostatic	1	
336505	MULTIPLIER KIT, 93 kV, Kinetix	1	
336644	EXTENSION KIT, Kinetix, low pressure	1	
336642	WRENCH, Kinetix, combination tool	1	
227583	PROTECTIVE COVER, bag, Kinetix	6	C
900349	PTFE-FILLED LUBRICANT, O-ring, (MagnaLube) , 0.75-oz tube	1	
247658	DIELECTRIC GREASE, applicator, 10 cc, 12 count	1	
-----	FLUID TIP	1	D
-----	AIR CAP	1	D
336468	TUBE, PTFE, $\frac{3}{8}$ -in. OD x $\frac{3}{32}$ -in. ID x 0.141-in. wall	1	E
336752	FERRULE, $\frac{3}{8}$ -in. tube, low pressure, hose	1	E
1028630	PLIERS, needle nose bent, Kinetix	1	
1028631	TOOL, needle, Kinetix	1	
1042496	PARTS POSTER, Kinetix Manual Air Spray and KVLP Spray Gun with $\frac{1}{4}$ -in. ID Fluid Hose	1	
1043242	PARTS POSTER, Kinetix Manual Air Spray and KVLP Spray Gun with $\frac{3}{8}$ -in. OD Fluid Tube	1	
<p>NOTE A: Choose only one fluid seal kit. Fluid seal kit 336679 is standard, fluid seal kit 336633 is optional.</p> <p>B: Kinetix spray guns are shipped with the standard gold packing cartridge. This durable packing cartridge is appropriate for most coating materials. Use the optional PTFE packing cartridge with harsh chemical solvents such as MEK.</p> <p>C: Order 227584 for a quantity of 12 protective cover bags.</p> <p>D: Refer to the <i>Kinetix Airspray Fluid Tip and Air Cap Selection Chart</i> and the <i>Kinetix KVLP Fluid Tip and Air Spray Selection Chart</i> included with this manual for available part numbers and descriptions.</p> <p>E: Only use with spray gun 336724.</p>			

**KVLP Compliance Kit**

Item	Part	Description	Quantity	Note
—	-----	COMPLIANCE KIT	1	A
1	325643	• GAUGE, air, 1.5-in. diameter, 0–30 psi	2	
2	972937	• CONNECTOR, female, 1/8-in. tube x 1/8-in. NPT	2	
3	-----	• TUBING, 1/8-in. diameter, gray (18 in.)	3	B
4	-----	• CAP, compliance, KVLP	1	A, C
5	971620	• • CONNECTOR, barbed, #3-56 x 1/8 in., brass	2	
6	325547	• RING, retaining, air cap	1	

NOTE A: Refer to the *Kinetix KVLP Fluid Tip and Air Cap Selection Chart* included with this manual for the correct part number.

B: Order tubing in one-foot increments. Two 18 in. sections are required.

C: Compliance caps can be ordered separately corresponding to different air caps used.

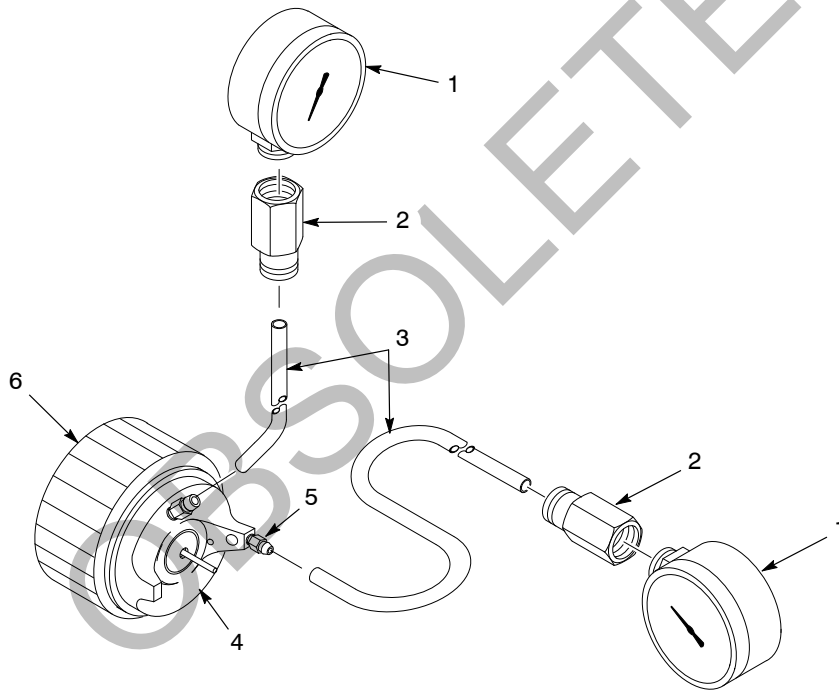

Figure 8-3 KVLP Compliance Kit Parts

## Adhesives, Sealants, and Lubricants

Use these adhesives, sealants, and lubricants when repairing your spray gun. Refer to the *Repair* or *Installation* sections for application instructions.

Part	Description	Quantity
900464	ADHESIVE, threadlocking (Loctite Removable 242)	1
900349	PTFE-FILLED LUBRICANT, O-ring, (MagnaLube) , 0.75-oz tube	1
247658	DIELECTRIC GREASE, applicator, 10 cc, 12 count	1

## Air Spray Conical Nozzles

Part	Description	Quantity
336608	10-in. CONICAL NOZZLE KIT, low pressure, 25.4 cm	1
336610	• TIP, fluid conical, electrostatic	1
336581	• CAP, conical	1
-----	• NOZZLE, 10 in. with insert, electrostatic	1
336678	• O-RING, Perlast, 0.375 x 0.50 x 0.063 in.	1
336569	• BACKUP RING, conductive, 0.39-in. ID x 0.045-in. thick, cut	1
336609	13-in. CONICAL NOZZLE KIT, low pressure, 33.1 cm	1
336610	• TIP, fluid conical, electrostatic	1
336582	• CAP, conical	1
-----	• NOZZLE, 13 in. with insert, electrostatic	1
336678	• O-RING, Perlast, 0.375 x 0.50 x 0.063 in.	1
336569	• BACKUP RING, conductive, 0.39-in. ID x 0.045-in. thick, cut	1

OBSOLETE

## Section 9

# Specifications

### Dimensions

Dimensions	Metric (cm)	English (in.)
Height	22.28	8.77
Length	30.48	12.00
Width	5.58	2.20
<b>NOTE:</b> The spray gun dimensions include the fluid and air fittings.		

### Weight

Weight	Metric (g)	English (oz)
Airspray/KVLP spray gun	837	29.5
<b>NOTE:</b> The spray gun weight includes the fluid and air fittings.		

### Operating Pressures

Operating Pressures	Metric	English
Maximum air input pressure	6.9 bar	100 psi
Maximum fluid input pressure	6.9 bar	100 psi
Maximum fluid temperature	82 °C	180 °F
<b>NOTE:</b> Supply air must be particulate free (5 microns maximum) and oil free. Use coalescing-type air filters.		

### KVLP Air Hose Requirements

KVLP Air Hose	Metric	English
Length	7.62 m	25 ft
	9.144 m	30 ft
Available ID for 7.62 m (25 ft) hose	7.94 mm	<sup>5</sup> / <sub>16</sub> in.
Available ID for 9.53 m (30 ft) hose	9.53 mm	<sup>3</sup> / <sub>8</sub> in.

## Air Spray Air Hose Requirements

Airspray Air Hose	Specification
Fitting size	1/4-in. NPSM, Male
Hose	You may use any grounding type air hose appropriate for your application needs.

## Standard Fitting Sizes

Spray Gun Standard Fitting Sizes	
Activation (trigger) air	1/4-in. NPSM, Male
Fluid fitting for spray gun, parts 336715	3/8-in. NPSM, Female
Fluid fitting for spray gun, parts 336724	3/8-in. NPSM, Male

## Gun Electrostatics

Maximum voltage: 93 kV

Maximum output rating current: 122 microamps

**NOTE:** Current draw greater than 50  $\mu$ A may affect spray pattern, transfer efficiency and finish. If the conductivity of your material causes excessive current draw, changing to the longer hose may be necessary.

Refer to *Selecting the Fluid Hose* on page 3-3 in the *Installation* section.

## Conductivity Range

Material Resistivity	Hose Length
Greater than 25 megohms/cm	Standard hose
Less than 25 megohms/cm	Long hose or 0.093-in. ID tubing

## Approvals

This spray gun has met the requirements for CE and FM approval.

## 1. DESCRIPTION

*NORDSON Corporation*

KINETIX High Pressure or TRILOGY Low Pressure liquid electrostatic guns have been designed and manufactured according to ATEX 94/9/CE directive, group II, category 2 G, with reference to EN 60079-0 and EN 50050 standards. The type of protection is EEx 0,24 mJ.

## 2. ELECTRICAL CHARACTERISTICS

### *IPS-20 Controller*

Rated voltage: 85 – 250VAC  
Rated current: 40VA

### *PISTOL (same for both applicators)*

Rated voltage: 93kV Max  
Rated current: 122µA  
Ambient temperature: -20°C to +40°C

## 3. MARKING

CE 1180  II 2 G

1180

II

2

G

EEx 0,24 mJ

Ambient temperature

n° of notified body (ATEX surveillance)

group II (surface)

category 2 apparatus

explosive atmospheres with caused by gas, mists or vapours

type of protection, gas group, temperature class

- 20 °C to + 40 °C

<i>Hazardous area</i>		<i>Categories according to 94/9/CE Directive</i>
Gas, mists or vapours	Zone 0	1 G
Gas, mists or vapours	Zone 1	2 G
Gas, mists or vapours	Zone 2	3 G

## 4. SAFETY INSTRUCTIONS FOR THE INSTALLATION IN HAZARDOUS AREA

KINETIX / TRILOGY liquid pistols shall be installed & maintained according to the applicable standards regarding electrical installations in hazardous area.

Before the installation READ CAREFULLY the INSTRUCTION MANUAL of the KINETIX / TRILOGY liquid pistol and IPS20 controller or associated apparatus.



**5. EXAMPLE OF APPLICATION**

This shows the applicators and how a typical system is configured.

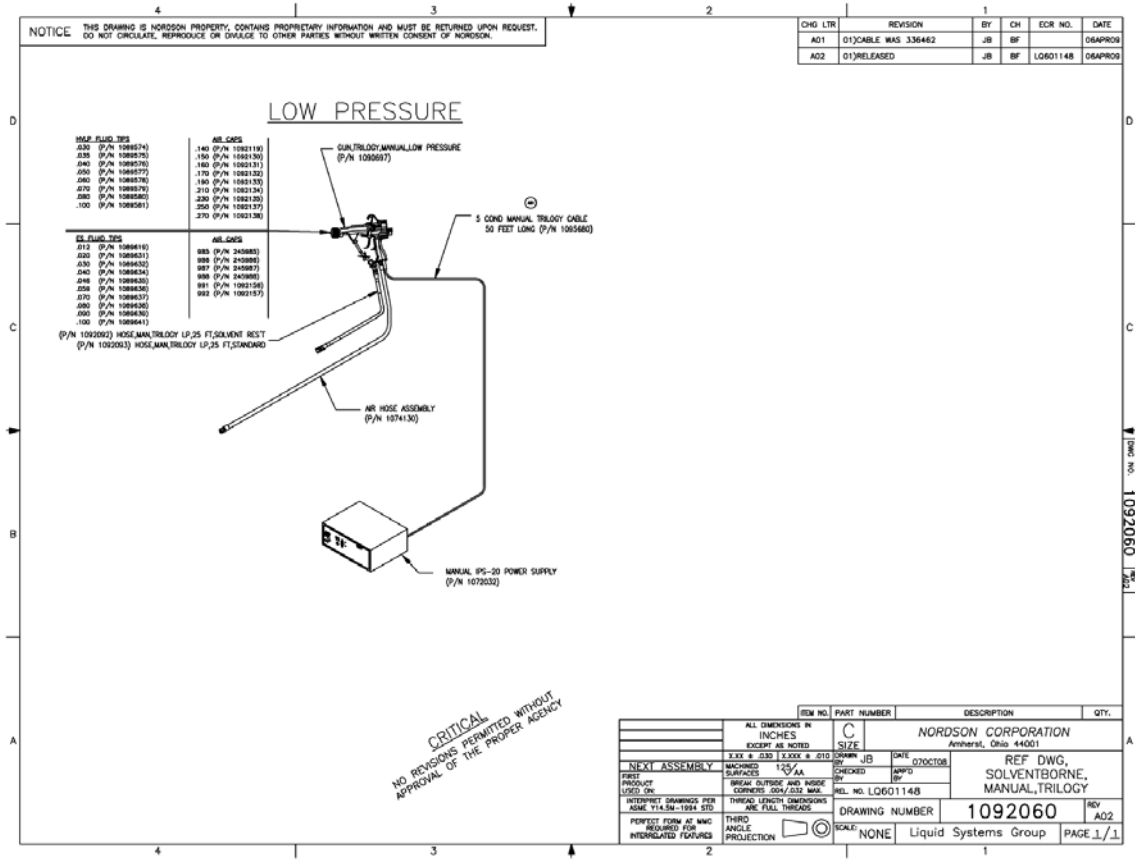

NOTICE THIS DRAWING IS NORDSON PROPERTY, CONTAINS PROPRIETARY INFORMATION AND MUST BE RETURNED UPON REQUEST. DO NOT CIRCULATE, REPRODUCE OR CHANGE TO OTHER PARTIES WITHOUT WRITTEN CONSENT OF NORDSON.

CHG LTR	REVISION	BY	CH	ECR NO.	DATE
ADD	(00) ISSUED	JRH	--	----	23NOV99
A01	(01) CRCTD PWR SPLY P/N	JRH	--	----	30NOV99
	(02) 33641 RING				
	(03) 33661,33662 & 33663 RING				
	(04)336716 & 336726 ADDD				
	(05)336717 & 33727 ADDD				
	(06) 33646 ADDD				
	(07) WIG 12 METERS				
	(08) 336715 & 336725 ADDD				
A09	(09) PRE-RELEASED	DAK		LQ 9370	25OCT00
A10	(10) RELEASED	DAK	BM	LQ 9377	09NOV00
	(11) 336724 & 336728 ADDD				
	(12) ADDD & IN HOSE				
A13	(13) 336540 RING, CHGD PICTORALLY	DAK	ACP	LQ 31569	20JUN01
A14	(14) REMOVE OBTULETED GUNS.	SRL	JW	GN300082	23MAR05
A15	(15) ADD KINETIX BELLOW GUN	JB	JW	LO300570	30OCT06
	(16) AIR HOSE ASBY P/N WIG 336733				
A17	(17) ADDD OPTIONAL HOSE P/Ns.	DC	MPW	GN300228	01DEC08
A18	(18) PART NUMBER WIG 297148	MHH	JF	LQ300509	15AUG07
A19	(19) LOW PRESSURE VERSION	DD	TT	LO601914	07JUL10
	ORIGL. REMOVED FROM DRAWING.				
	P/N 336466 REMOVED.				

### HIGH PRESSURE

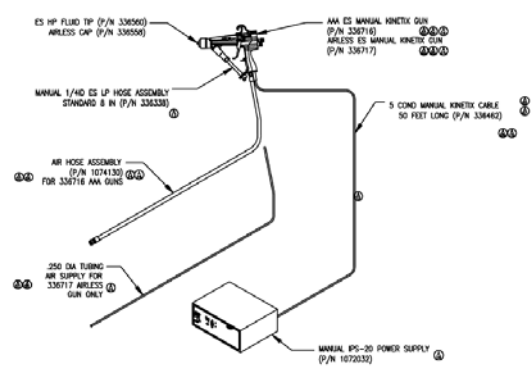

**CRITICAL**  
NO REVISIONS PERMITTED WITHOUT APPROVAL OF THE PROPER AGENCY

ITEM NO.	PART NUMBER	DESCRIPTION	QTY.
		ALL DIMENSIONS IN INCHES EXCEPT AS NOTED	
		<b>C</b> SIZE	
		<b>NORDSON CORPORATION</b> Amherst, Ohio 44001	
		REF DWG. SOLVENTBORNE, MAN KINETIX	
		DRAWING NUMBER <b>336449</b>	REV <b>A19</b>
		SCALE: NONE	Page 1/1

OBSOLETE

## 6. DECLARATION OF CONFORMITY

*Nordson Corporation  
Headquarters in Westlake Ohio, USA  
declare under our sole responsibility that the products*

**KINETIX High Pressure or TRILOGY Low Pressure Liquid Applicators including Air Spray /  
KVLP, Air Assisted Airless and Airless Models used with IPS-20 Manual Controllers.**

*to which this declaration relates complies with the following Directives:*

- Machinery Directive 2006/42/EC
- EMC Directive 2004/108/EC
- ATEX Directive 94/9/EC

*The conformity are under observance of the following standards or standards documents:*

EN12100 (1998)	EN61000-6-2 (2007)	
EN60079-0 (2006)	EN61000-6-3 (2006)	FM7260 (1996)
EN50050 (2006)	EN55011 (2007)	

*Type of protection:*

- II 2 G EEx 0,24 mJ , Ambient temperature: - 20°C to + 40°C

*EC type-examination certificate n°:*

- CESI 01ATEX 017
- Milan Italy

*N° of notified body (ATEX surveillance)*

- 1180 (Baseefa) (Buxton, Derbyshire, UK)

*ISO9000 certificate*

DNV

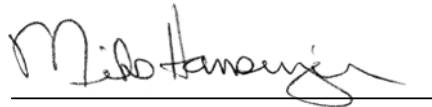

Mike Hansinger  
Manager Engineering Development

Date : 03 Sept 2010

### **Nordson Authorized Representative in the EU**

**Contact:** Operations Manager  
Industrial Coating Systems  
Nordson Deutschland GmbH  
Heinrich-Hertz-StraBe 42-44  
D-40699 Erkrath