

Zero-Cavity Automatic Dispensing Valves

Part 107 024A



NORDSON CORPORATION • AMHERST, OHIO • USA

Nordson Corporation welcomes requests for information, comments and inquiries about its products.

Address all correspondence to

Nordson Corporation
555 Jackson Street
Amherst, OH 44001

Notice

This is a Nordson Corporation publication which is protected by copyright. No part of this document may be photocopied, reproduced, or translated to another language without the prior written consent of Nordson Corporation. The information contained in this publication is subject to change without notice.

Trademarks

100 Plus, Blue Box, ChromaFlex, CleanSleeve, CleanSpray, Control Coat, Cross-Cut, Easy Coat, Econo-Coat, Flow Sentry, Isocoil, Isocore, Iso-Flo, Nordson, the Nordson logo, PRX, Pro-Flo, RBX, Ready-Coat, Rhino, Select Coat, Select Cure, Shur-Lok, Smart Spray, System Sentry, Thread Coat, Tribomatic, and Versa-Spray are registered trademarks of Nordson Corporation.

CPX, CanWorks, Excel 2000, PowderGrid, Pulse Spray, SCF, Versa-Coat, Versa Screen, and Package of Values are trademarks of Nordson Corporation.

All other trademarks are the property of their respective owners.

Zero-Cavity Automatic Dispensing Valves

1. Safety

Introduction

This section contains general safety instructions for using your Nordson equipment. Task- and equipment-specific warnings are included in other sections of this manual where appropriate. Note all warnings and follow all instructions carefully. Failure to do so may result in personal injury, death, or property damage.

To use this equipment safely,

- read and become familiar with the general safety instructions provided in this section of the manual before installing, operating, maintaining, or repairing this equipment.
- read and carefully follow the instructions given throughout this manual for performing specific tasks and working with specific equipment.
- store this manual within easy reach of personnel installing, operating, maintaining, or repairing this equipment.
- follow all applicable safety procedures required by your company, industry standards, and government or other regulatory agencies.
- obtain and read Material Safety Data Sheets (MSDS) for all materials used. Contact your material supplier for this information.

Safety Symbols

Become familiar with the safety symbols presented in this section. These symbols will alert you to safety hazards and conditions that may result in personal injury, death, or property and equipment damage.



WARNING: Failure to observe this warning may result in personal injury, death, or equipment damage.

Safety Symbols (contd)



WARNING: Risk of electrical shock. Failure to observe this warning may result in personal injury, death, or equipment damage.



WARNING: Disconnect equipment from line voltage. Failure to observe this warning may result in personal injury, death, or equipment damage.



WARNING: Risk of explosion or fire. Fire, open flames, and smoking prohibited.



WARNING: Wear protective clothing, safety goggles, and approved respiratory protection. Failure to observe may result in serious injury.



WARNING: Hot! Risk of burns. Wear heat-protective clothing, safety goggles with side shields and/or heat-protective gloves depending on the symbol shown.



WARNING: System or material pressurized. Relieve pressure. Failure to observe this warning may result in serious injury or death.



WARNING: Injection hazard. Do not point this device at yourself or other personnel. Failure to observe this warning may result in serious injury or death.



CAUTION: Failure to observe may result in equipment damage.



CAUTION: Hot surface. Failure to observe may result in burns.

Qualified Personnel

“Qualified personnel” is defined here as individuals who thoroughly understand the equipment and its safe operation, maintenance, and repair. Qualified personnel are physically capable of performing the required tasks, familiar with all relevant safety rules and regulations, and have been trained to safely install, operate, maintain, and repair the equipment. It is the responsibility of the company operating the equipment to see that its personnel meet these requirements.

Intended Use



WARNING: Use of this equipment in ways other than described in this manual may result in personal injury, death, or property and equipment damage. Use this equipment only as described in this manual.

Nordson Corporation cannot be responsible for injuries or damages resulting from nonstandard, unintended applications of its equipment. This equipment is designed and intended only for the purpose described in this manual. Uses not described in this manual are considered unintended uses and may result in serious personal injury, death, or property damage. Unintended uses may result from taking the following actions:

- making changes to equipment that have not been recommended or described in this manual or using parts that are not genuine Nordson replacement parts
- failing to make sure that auxiliary equipment complies with approval agency requirements, local codes, and all applicable safety standards
- using materials or auxiliary equipment that are inappropriate or incompatible with your Nordson equipment
- allowing unqualified personnel to perform any task

Installation

Read the installation section of all system component manuals before installing your equipment. A thorough understanding of system components and their requirements will help you to install the system safely and efficiently.

- Allow only qualified personnel to install Nordson and auxiliary equipment.
- Use only approved equipment. Using unapproved equipment in an approved system may void agency approvals.

Installation *(contd)*

- Make sure all equipment is rated and approved for the environment in which you are using it.
- Follow all instructions for installing components and accessories.
- Install locking, manual shutoff valves in the air supply lines to the system. This allows you to relieve air pressure and lock out the pneumatic system before undertaking maintenance and repairs.
- Ground (and fuse, if necessary) all electrically conductive equipment within 10 feet (3 meters) of the spray area or according to its rated current consumption. (See the ID plate on your equipment.) Ungrounded conductive equipment can store a static charge which could ignite a fire or cause an explosion if a hot spark is discharged.
- Route electrical wiring, cables, hoses, and air supply tubing along a protected path. Make sure they will not be damaged. Do not bend cables or hoses around a radius of less than 6 in. (152 mm).
- Do not use unapproved fluid hoses. Solvents may cause them to deteriorate rapidly and allow flammable liquids or pressurized material to escape.
- Protect components from damage, wear, and harsh environmental conditions.
- Allow ample room for maintenance, material supply container drop-off and loading, panel accessibility, and cover removal.
- Protect equipment with safety devices as specified by applicable safety regulations.

Operation

- If safety devices must be removed for installation, install them immediately after the work is completed and check them for proper functioning.

Only qualified personnel, physically capable of operating the equipment and with no impairments to their judgement or reaction times, are permitted to operate this equipment.

Read all component manuals before operating your Nordson equipment. A thorough understanding of components and their operation will help you operate the system safely and efficiently.

- Do not deactivate or bypass automatic safety interlocks, locked-out electrical disconnects, or pneumatic valves.

Operation (contd)

- Never operate equipment with a known malfunction or leak.
- Do not attempt to operate electrical equipment if standing water is present.
- Know where EMERGENCY STOP buttons, safety shutoff components, and fire extinguisher are located. Make sure they work. If a component malfunctions, shut down and lock out the equipment immediately.
- Know the pinch points, temperatures, pressures, and dispense material composition for all equipment that you are working with. Recognize potential hazards associated with these and exercise appropriate caution.
- Use this equipment only in the environments for which it is rated. Do not operate this equipment in humid, flammable, or explosive environments unless it has been rated for safe operation in these environments.
- Before operating, make sure all equipment, objects being sprayed, and fluid containers are connected to a true earth ground.
- Never touch exposed electrical connections or equipment while the power is ON.
- If you notice electrical arcing in a spray area, shut down the system immediately. An arc can cause a fire or explosion.
- Do not operate the equipment at pressures higher than the rated maximum working pressure of any component in the system.
- Keep parts of the body or loose clothing away from moving equipment or parts. Remove jewelry and cover or tie back long hair.
- Shut off moving equipment before taking measurements or inspecting workpieces.
- Wear National Institute of Occupational Safety and Health (NIOSH) approved respirators while operating spray equipment and when performing maintenance and cleaning tasks.
- Wear gloves, eye protection, and protective clothing to protect your skin when operating equipment.

Operation *(contd)*

- If your skin has been exposed to dispense materials or solvents wash frequently with soap and water, especially before eating or drinking. Do not use solvents to remove coating materials from your skin.
- Do not use high-pressure compressed air to blow dust or powder off your skin or clothes. High-pressure compressed air can be injected under the skin and cause serious injury or death. Treat all high-pressure fittings and hoses as if they could leak and cause injury.
- Never point handguns or applicator nozzles at yourself or other persons.
- Do not smoke in the spray area. A lit cigarette could ignite a fire or cause an explosion.
- Keep paint pumps, pressure pots, and containers of flammable materials far enough away from spray booths to prevent their inclusion in a booth fire.
- Do not use fluids that will corrode the equipment.

Less-obvious Dangers

Operators should also be aware of less-obvious dangers in the workplace that often cannot be completely eliminated:

- exposed surfaces on the equipment which may be hot or have sharp edges and cannot be practically safeguarded
- ungrounded conductive equipment which may continue to store an electrostatic charge after the equipment has been shut off
- vapors and materials which may cause allergic reactions or other health problems
- automatic hydraulic, pneumatic, or mechanical equipment or parts that may move without warning
- unguarded, moving mechanical assemblies

Action in the Event of a System or Component Malfunction

Do not operate a system that contains malfunctioning components. If a component malfunctions, turn the system OFF immediately.

- Disconnect and lock out electrical power. Close and lock out hydraulic and pneumatic shutoff valves and relieve pressures.
- Allow only qualified personnel to make repairs.

Maintenance and Repair

Allow only qualified personnel to perform maintenance, troubleshooting, and repair tasks.

- Always wear appropriate protective clothing and use safety devices when working on this equipment.
- Follow the recommended maintenance procedures in your equipment manuals.
- Do not service or adjust any equipment unless another person trained in first aid and CPR is present.
- Use only genuine Nordson replacement parts. Using unapproved parts or making unapproved modifications to equipment may void agency approvals and create safety hazards.
- Refer to MSDS before using solvents to clean this equipment. The MSDS will provide use, storage, and disposal information about the solvent. Read this information carefully and follow all instructions.



WARNING: Note the flash point of the cleaning solvent used. Only use controlled methods and equipment, such as temperature-controlled or explosion-protected heaters, to heat cleaning solvent. Observe explosion-prevention regulations and follow applicable safety instructions.

- Never use an open flame to clean the unit or components of the unit.
- Do not store flammable materials in the spray area or room. Keep paint pumps, pressure pots, and containers of flammable materials far enough away from spray booths to prevent their inclusion in a booth fire. If a fire or explosion occurs, flammable materials in the area will increase the chances and the extent of personal injuries and property damage.

Maintenance and Repair

(contd)

- Make sure that the room where you are working is sufficiently ventilated. Avoid breathing vapors over prolonged periods of time.
- Make sure the spray area floor is conductive to ground and that the operator's platform is grounded.
- Connect all disconnected equipment ground cables and wires after servicing the equipment. Ground conductive equipment.
- Disconnect, lock out, and tag electrical power at a disconnect or breaker in the service line ahead of electrical equipment before servicing.



WARNING: Service lines connected to panel disconnect switches may still be energized unless they are disconnected. Make sure the power is off before servicing. Wait five minutes for the capacitors to discharge after shutting off the electrical power.

- Do not attempt to service electrical equipment if there is standing water present. Do not service electrical equipment in a high-humidity environment.
- Use tools with insulated handles when working with electrical equipment.
- Relieve air and fluid pressures before servicing equipment. Follow the specific instructions in this manual.
- If you must disassemble a spring-loaded component, carefully preload the spring first if it is possible to do so.

Material and Solvent Precautions

Heated materials may cause severe burns on contact. Remember that some materials, even solid materials, may retain heat for some time. If you are burned by a heated material, immediately cool the affected skin with lots of cool, clean water. Do not try to remove hot, melted material from the skin. Seek immediate medical attention.



WARNING: Hot! Risk of burns. Wear heat-protective clothing, safety goggles with side shields and/or heat-protective gloves.



High-pressure fluids, unless they are safely contained, are extremely hazardous. A jet of high-pressure fluid can act like a knife or needle, penetrate skin and muscle, and inject itself into your body. Injected fluids can cause toxic poisoning.

Do not treat an injection injury as minor. Seek medical care immediately. Inform the medical staff at the hospital that you have an injection injury and identify the fluid that was injected. If possible, give the doctor copies of the MSDS for the injected fluid and for any additives, such as solvents, that are in the injected fluid.

Nordson recommends that you carry a National Safety Equipment Manufacturers Association (NSEMA) wallet card to give to emergency medical staff in the event of an injection injury. These cards are supplied with the equipment. Additional cards are available free from Nordson Corporation.



WARNING: Injection hazard. Do not go near a known leak in a hose or fitting, and stay clear of all dispensing device nozzles or orifices. Do not point a dispensing device at yourself or other personnel. The high-pressure fluid stream can penetrate skin and inject fluid into the body causing serious injury or death.

- Always handle fluid dispensing devices carefully. Do not point the nozzle of a pressurized device at yourself or other personnel.
- Never place hands, fingers, or other parts of your body directly over a nozzle or near a leak in a high-pressure system.

Material and Solvent Precautions (contd)

- Never “back-flush” the nozzles. Blocking a nozzle causes the high-pressure fluid to change direction. An injection injury may result.
- Always relieve system pressure before servicing equipment. Trigger all dispensing devices and bleed off system pressure.

See Table 1. Halogenated hydrocarbon solvents can cause an explosion when used with aluminum components in a pressurized fluid pumping system (pumps, heaters, filters, valves, spray guns, and tanks). The explosion could cause serious bodily injury, death, or substantial property damage. No available stabilizers will prevent this violent reaction from happening.



WARNING: Never use halogenated hydrocarbon solvents to clean aluminum parts or to flush any system. Cleaning agents, coatings and paints, or adhesives may contain halogenated hydrocarbon solvents. Obtain and read MSDS for each material and solvent being used.

- Contact your solvent supplier to determine whether your existing materials and solvents contain halogenated hydrocarbons or to obtain a suitable, nonhalogenated hydrocarbon solvent for cleaning and flushing your system.
- If you must use halogenated hydrocarbon solvents, consult your Nordson representative about compatible Nordson components.

Table 1 Solvents Containing Halogenated Fluids

Chlorinated Solvents	Iodinated Solvents	Brominated Solvents	Fluorocarbon Solvents
Carbon Tetrachloride	Ethyl Iodide	Ethylene Dibromide	Dichlorofluoromethane
Chloroform	Methyl Iodide	Methyl Bromide	Trichlorofluoromethane
Ethylene Dichloride	N-butyl Iodide	Methylene Chlorobromide	Freon
Methylene Chloride	Propyl Iodide		
1-1-1 Trichloroethane			
Monochlorobenzene			
Orthodichlorobenzene			
Perchloroethylene			
Trichloroethylene			

Disposal

Dispose of equipment and materials used in operation and cleaning according to your local regulations.

2. Description

Introduction

See Figure 1.

Zero-cavity dispensing valves have a matched needle and seat machined to close tolerance, which eliminates the formation of material pockets. This design provides a self-cleaning action that prevents material blockages, dispensing tails, and adhesive stringing.

Zero-cavity dispensing valves are available with 3-, 4-, and 5-mm nozzles. Each can be supplied with an optional manifold mount.

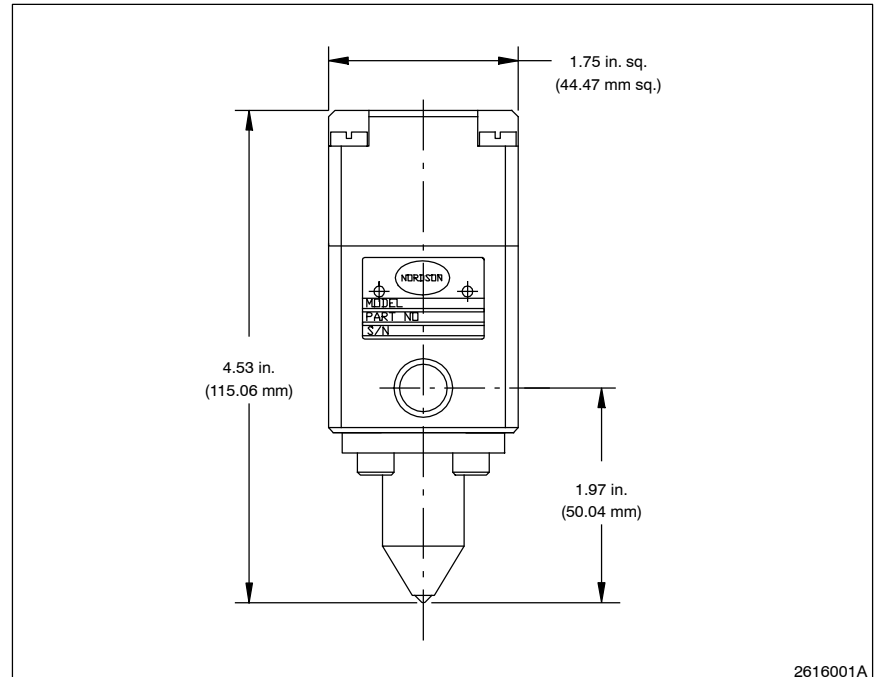
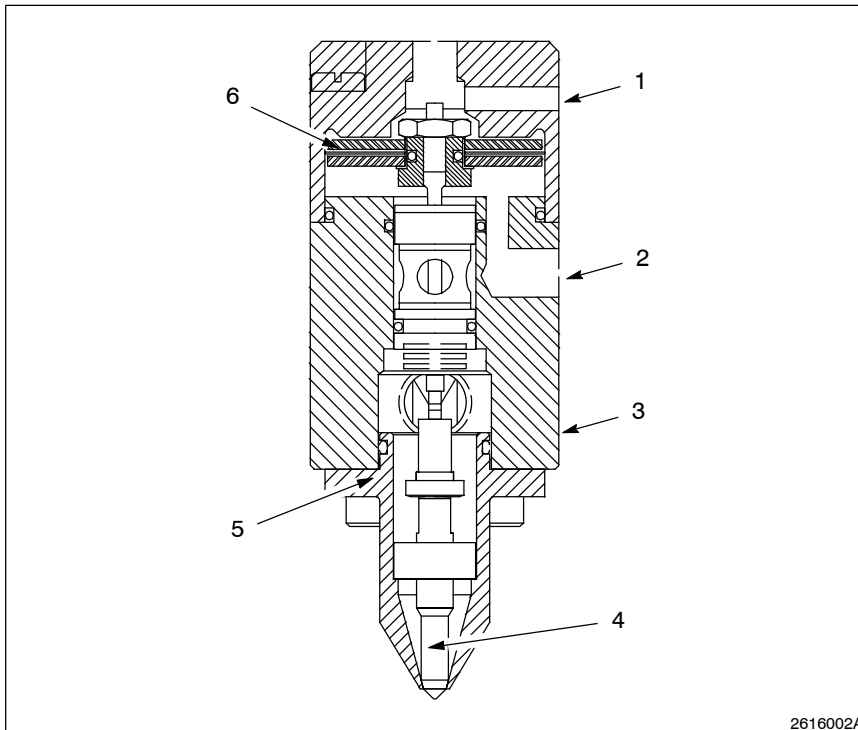

Fig. 1 Zero-cavity dispensing valve

Theory of Operation

See Figure 2.

When air is supplied to the valve-open air inlet (2), the piston is pushed upward pulling the needle (4) off the seat (5). Material flows in the material inlet (3) and out the nozzle. When air is shut off from the valve-open air inlet, a spring in the packing cartridge forces the needle back in the seat and stops material dispensing. Install a quick-release valve in the air supply line near the valve-open air inlet to achieve better dispensing response. For optimal performance, supply air to the valve-close air inlet (1). The air forces the piston downward to quickly return the needle to the seat.



- 1. Valve-close air inlet
- 2. Valve-open air inlet
- 3. Material inlet
- 4. Needle
- 5. Seat
- 6. Piston

2616002A

Fig. 2 Cutaway view of zero-cavity valve

3. Installation



WARNING: Allow only qualified personnel to perform the following tasks. Observe and follow the safety instructions in this document and all other related documentation.

Inspection

Inspect the dispensing valve for dents, scratches, corrosion, and other physical damage. If any damage is visible, contact a Nordson representative immediately.

Installation



WARNING: System or material pressurized. Relieve pressure. Failure to observe this warning may result in serious injury or death.

Dispensing Valve Mounting

See Figure 3.

Mount the dispensing valve to a fixed, mobile, or robotic fixture using a customer-supplied adaptor specifically designed for the application. The adaptor must provide two $\frac{1}{4}$ -in. (M6) threaded bolts to accept the hollow dowels (1) on the body. The correct bolt spacing is shown in Figure 3.

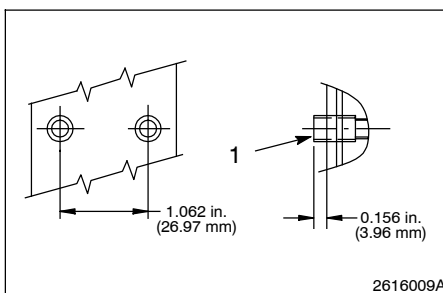

Fig. 3 Mounting hole spacing

1. Hollow dowels

Supply Air Connection

See Figure 2.

Air must be supplied to the valve-open air inlet (2). A spring will force the valve closed when air is shut off to the valve-open air inlet. To obtain quicker response:

- mount an air-operated, quick-release valve near the valve-open air inlet, or
- supply air to the valve-close air inlet (1).

Supply Air Connection (contd.)

Supply air must be taken from an oil-free shop air outlet that will maintain a pressure of at least 70 psi (4.83 bar). The dispensing valve will not operate properly without the required amount of air pressure (70 to 120 psi (4.83 to 8.28 bar)). Dispensing performance will increase at higher pneumatic pressures.

Follow these steps to install the dispensing valve:

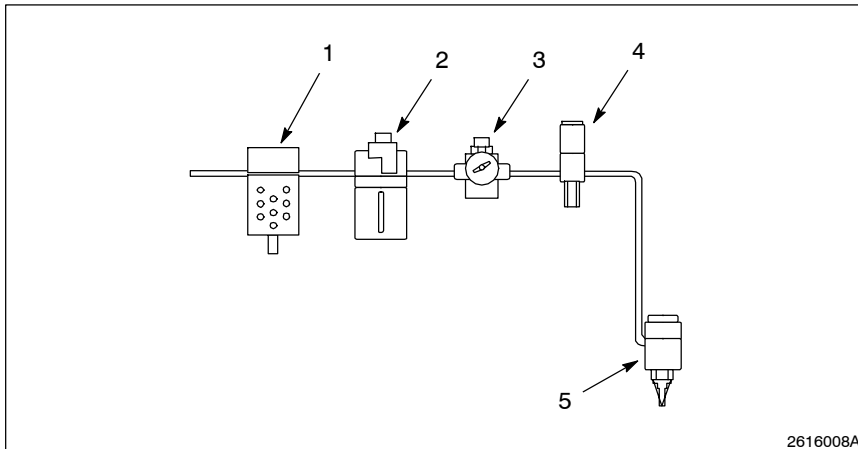

1. See Figure 4. Install a filter (1), lubricator (2), and regulator (3) in the air supply line.
2. Install a solenoid valve (4) as close to the dispensing valve as possible. Attach an air line to the A port of the solenoid valve.

NOTE: If the solenoid is too far from the dispensing valve, dispensing action may lag.

Fig. 4 Schematic of the air line connection to a dispensing valve

- | | |
|---------------|---------------------|
| 1. Filter | 4. Solenoid valve |
| 2. Lubricator | 5. Dispensing valve |
| 3. Regulator | |

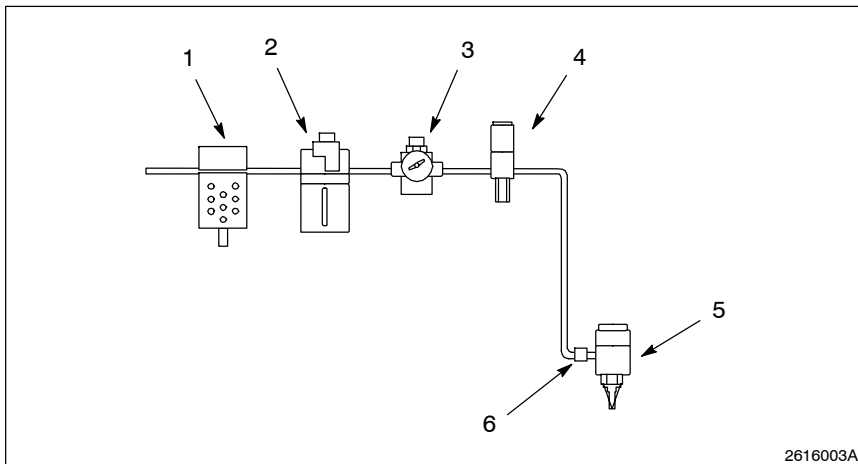

3. See Figure 5. If you are using a quick-release valve (6), install it as close to the valve-open air inlet as possible.
4. Attach an air supply line to the valve-open air inlet on the valve.

Fig. 5 Schematic of air line connections with quick-release valves on the valve-open air inlet

- | | |
|---------------|------------------------|
| 1. Filter | 4. Solenoid valve |
| 2. Lubricator | 5. Dispensing valve |
| 3. Regulator | 6. Quick-release valve |

Supply Air Connection (contd.)

Fig. 6 Schematic of air line connections with air-assisted valve closure

- | | |
|-------------------|--------------------------------------|
| 1. Filter | 5. Air line to valve-close air inlet |
| 2. Lubricator | 6. Dispensing valve |
| 3. Regulator | 7. Air line to valve-open air inlet |
| 4. Solenoid valve | |

5. See Figure 6. If you are using air-assisted closure, attach an air line (5) to the B port of the solenoid valve. Attach an air supply line to the valve-close air inlet on the valve.

Material Supply Line

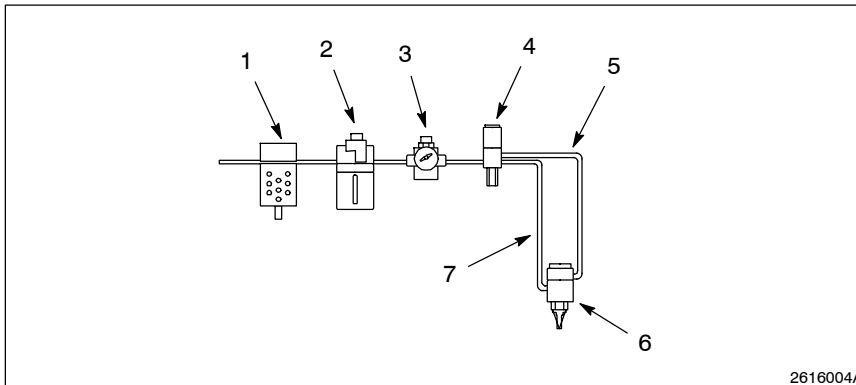
Each dispensing valve has two material inlet ports located on opposite sides of the body. Use either port and leave the other plugged.

Connect a Nordson swivel (purchased separately) to the material inlet. Refer to the manual, *Nordson High Pressure Fluid Swivel Connections*, for appropriate part numbers, connector sizes, and possible configurations. If additional assistance is needed, contact your Nordson representative.

If a standard material inlet fitting is required, use either a straight fitting or a 90°-elbow with a JIC-6 hose connection ($\frac{9}{16}$ -18 thread).

4. Operation

WARNING: Allow only qualified personnel to perform the following tasks. Observe and follow the safety instructions in this document and all other related documentation.

Introduction

Begin material dispensing by activating the valve-open air through the A port of the solenoid valve. Stop dispensing by turning off air through the A port. For air-assisted closure, activate the valve-close air through the B port of the solenoid valve.

Dispensing Valve Purging

After the dispensing valve has been installed, purge it to remove air from the material hose and nozzle. Place a material waste container under the nozzle.

Purge the dispensing valve until material flows freely from the nozzle.

5. Maintenance

General

Follow a preventive maintenance schedule to keep your dispensing valves operating efficiently.



WARNING: System or material pressurized. Relieve pressure. Failure to observe this warning may result in serious injury or death.



WARNING: Wear protective clothing, safety goggles, and approved respiratory protection. Failure to observe may result in serious injury.



Daily

- Check the nozzle for wear. Replace it when necessary.

Periodically

- Check the air lines and the material supply hose for leaks or damage. Replace lines and hoses when necessary.
- Make sure the dispensing valve is mounted securely.
- Clean the filter in the air supply line.

6. Troubleshooting



WARNING: Allow only qualified personnel to perform the following tasks. Observe and follow the safety instructions in this document and all other related documentation.

Introduction

This section contains troubleshooting procedures. These procedures cover only the most common problems that you may encounter. If you cannot solve the problem with the information given here, contact your local Nordson representative for help.

Problem		Page
1.	Leaking around seat	17
2.	Leaking through weep hole in valve body	17
3.	Dispensing valve responds slowly.	17

Troubleshooting Charts

NOTE: Some problems presented in this section may originate with other components in the system and not with the dispensing valve. If the corrective actions described here do not solve the problem, see the appropriate system manuals for further suggestions.

Problem	Possible Cause	Corrective Action	Refer to
1. Leaking around seat	Dirty or damaged metal sealing surfaces	Clean or replace needle and seat.	Repair section
2. Leaking through weep hole in valve body	Worn packing cartridge	Replace packing cartridge and install seal kit.	Repair section
3. Dispensing valve responds slowly.	Air piston assembly worn or out of adjustment	Adjust or replace air piston assembly.	Repair section
	Low air pressure to solenoid	Increase air pressure to solenoid.	
	Long air supply lines to valve	Mount solenoid on valve or as close as possible.	

7. Repair



WARNING: Allow only qualified personnel to perform the following tasks. Observe and follow the safety instructions in this document and all other related documentation.



WARNING: Disconnect equipment from line voltage. Failure to observe this warning may result in personal injury, death, or equipment damage.

Disconnect, lock out, and tag electrical power at a disconnect or breaker in the service line ahead of electrical equipment before servicing.



WARNING: System or material pressurized. Relieve pressure. Failure to observe this warning may result in serious injury or death.

Tools and Supplies Required

The following tools are required for servicing the dispensing valve:

- two adjustment wrenches

The following supplies are recommended for use during repair procedures:

- PTFE grease
- threadlock compound

Removing the Valve from the Fixture

1. Shut off the drum unloader.
2. Purge the dispensing valve to relieve the pressure in the hose and valve.
3. Shut off and lock out all power to the system.
4. Disconnect the material supply hose from the material inlet fitting on the valve.
5. Disconnect the air lines from the valve.
6. Remove the valve from the fixture.

Disassembling the Dispensing Valve

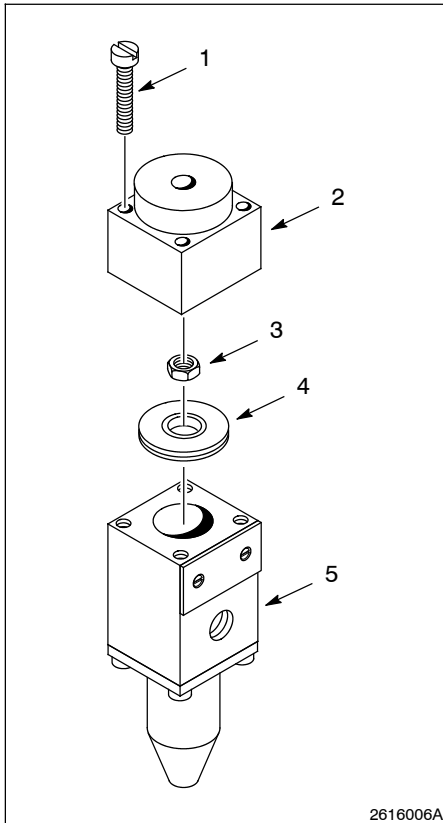

Fig. 7 Removing dispensing valve components

- | | |
|---------------------|--------------------|
| 1. Screw | 4. Piston assembly |
| 2. Air cylinder cap | 5. Body |
| 3. Nut | |

See Figure 7.

1. Remove the screws (1) and air cylinder cap (2) from the body.
2. See Figure 8. Place an adjustment wrench (7) on the hex of the seal lock nut (4). Remove the lock nut (2) from the top of the piston with another adjustment wrench.
3. Rotate the piston and lock nut counterclockwise and remove it from the packing cartridge (Figure 9, (9)).
4. See Figure 9. Remove the screws (13) and seat (12) from the body (7).
5. Hold the packing cartridge (9) steady with an adjustment wrench while removing the needle (10) with a second adjustment wrench.

If you are reusing the piston assembly, replace the O-ring (3) as described next, then return the assembly to the air cylinder cap to retain the shape of the preformed seals.

NOTE: Seals should face away from each other at the edge of the piston assembly.

1. See Figure 9. Remove the seal lock nut (4) and O-ring (3) from the center of the piston. Lubricate a new O-ring with PTFE grease, insert it in the piston, and replace the seal lock nut.
2. See Figure 7. Insert the piston assembly into the air cylinder cap with the seal lock nut facing outward. Be careful not to pinch the seals.

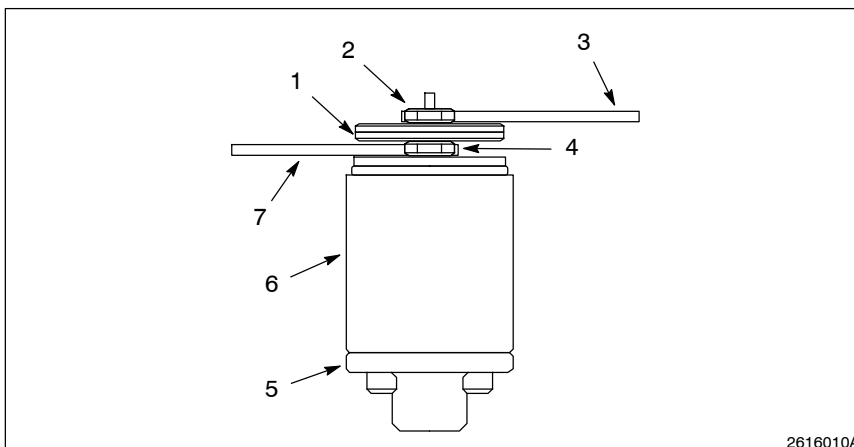
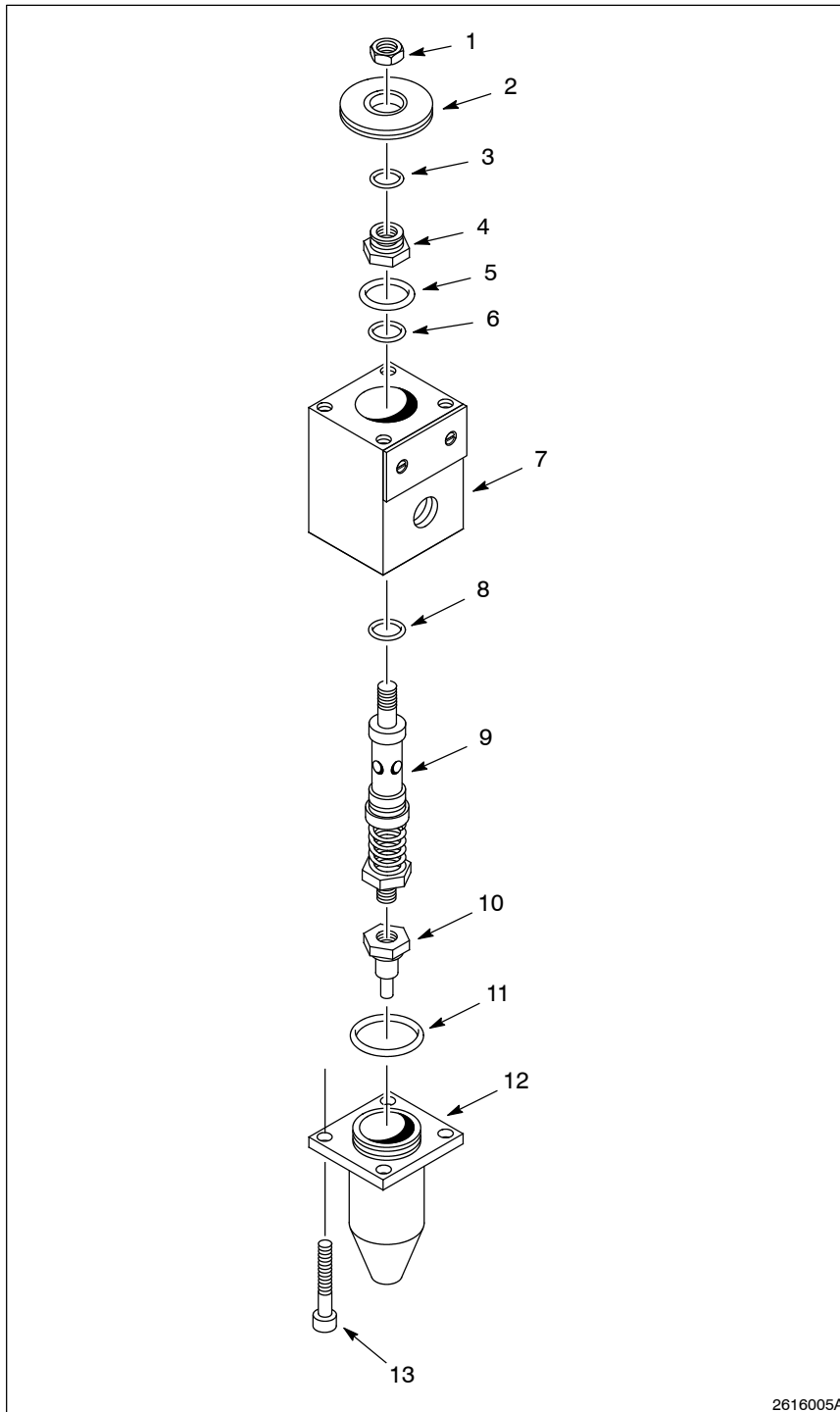

Fig. 8 Removing the piston assembly

1. Piston assembly
2. Lock nut
3. Adjustment wrench
4. Seal lock nut
5. Seat
6. Body
7. Adjustment wrench



- 1. Hex nut
- 2. Piston
- 3. O-ring
- 4. Seal lock nut
- 5. O-ring
- 6. O-ring
- 7. Body
- 8. O-ring
- 9. Packing cartridge
- 10. Needle
- 11. O-ring
- 12. Seat
- 13. Screw

Fig. 9 Disassembly of dispensing valve components

2616005A

Replacing the O-rings

See Figure 9.

1. Remove the O-ring (8) from the packing cartridge (9). Lubricate and install a new one.
2. Remove the O-ring (6) from the body interior with an O-ring removal tool. Lubricate and install a new one.
3. Remove the O-ring (5) from the body with an O-ring removal tool. Lubricate and install a new one.
4. Remove the O-ring (11) from the seat (12). Lubricate and install a new one.

Assembling the Dispensing Valve

See Figure 9.

NOTE: The needle (10) and seat (12) are a matched set. If either needs replaced, replace the pair.

1. Hold the packing cartridge (9) steady with an adjustment wrench while installing the needle (10) with a second adjustment wrench.
2. If you are reusing the piston assembly, remove it from the air cylinder by threading the packing cartridge (9) into the seal lock nut. Remove the piston with an even pulling force. Unthread the packing cartridge.

NOTE: Perform the remaining assembly steps immediately so the preformed seals do not lose their shape.

3. Lubricate the interior of the body (7) with PTFE grease. Insert the packing cartridge into the body.
4. Attach the seat (12) to the body with four screws (13).
5. If you are installing a new piston, remove it from the shipping fixture. Make sure the seal lock nut (4) is tight against the piston.
6. Thread the seal lock nut (4) of the piston assembly onto the packing cartridge (9), so the threads are engaged several turns.
7. Make sure the piston and inside of the air cylinder cap are lubricated with PTFE grease.

Assembling the Dispensing Valve *(contd)*

8. See Figure 8. Turn the seal lock nut (4) clockwise with an adjustment wrench to tighten the piston assembly on the packing cartridge. Tighten the nut until the wrench makes contact with both the body and piston, but can still be removed. Place a drop of threadlock compound on the threads above the piston.
9. Tighten the top lock nut (2) with a second adjustment wrench (3). Remove the first wrench from beneath the piston.
10. See Figure 7. Install the air cylinder cap (2) over the piston assembly. Be careful not to damage the seals. Rotate the cap so the air inlets are in the correct location for your application. Attach the cap with four screws (1).
11. If air or fluid line fittings were removed, coat the threads with threadlock compound and reinstall them.
12. Mount the dispensing valve to your fixture and attach the air material supply lines.

Cleaning the Seat

See Figure 9.

1. Remove the four screws (13) holding the seat (12) to the valve body (7).
2. Remove the O-ring (11) and keep in a safe place.
3. Clean the seat thoroughly with an appropriate solvent.
4. Replace the O-ring (11) and seat (12) and tighten the screws (13).

8. Parts

Introduction

To order parts, contact your distributor or local Nordson representative. Use this five-column parts list, and the accompanying illustration, to describe and locate parts.

Using the Illustrated Parts List

Numbers in the Item column correspond to numbers that identify parts in illustrations following each parts list. The code NS (not shown) indicates that a listed part is not illustrated. A dash (—) is used when the part number applies to all parts in the illustration.

The six-digit number in the Part column is the Nordson Corporation part number. A series of dashes in this column (- - - - -) means the part cannot be ordered separately.

The Description column gives the part name, as well as its dimensions and other characteristics when appropriate. Indentions show the relationships between assemblies, subassemblies, and parts.

Item	Part	Description	Quantity	Note
—	000 000	Assembly	1	
1	000 000	• Subassembly	2	A
2	000 000	• • Part	1	

- If you order the assembly, items 1 and 2 will be included.
- If you order item 1, item 2 will be included.
- If you order item 2, you will receive item 2 only.

The number in the Quantity column is the quantity required per unit, assembly, or subassembly. The code AR (As Required) is used if the part number is a bulk item ordered in quantities or if the quantity per assembly depends on the product version or model.

Letters in the Note column refer to notes at the end of each parts list. Notes contain important information about usage and ordering. Special attention should be given to notes.

Dispensing Valves Parts List See Figure 10.

Item	Part	Description	Quantity	Note
—	170 509	Dispensing valve, zero-cavity, 3 mm	1	
NS	170 510	Dispensing valve, zero-cavity, 4 mm	1	
NS	170 511	Dispensing valve, zero-cavity, 5 mm	1	
NS	175 593	Dispensing valve, zero-cavity, manifold mount	1	
1	982 386	• Screw, skt. hd., M5 x 35	4	
2	170 523	• Cap, air cylinder	1	
NS	145 897	• Kit, service, air piston	1	A
3	945 055	• • O-ring, Buna-N, 1.428 ID x 0.070 W	1	
4	984 120	• • Nut, hex, spl., #10-32	1	
5	-----	• • Piston, lock nut assembly	1	
7	240 274	• • Nut, seal lock	1	
8	940 151	• O-ring, Viton, 0.563 ID x 0.063 W	1	
9	170 242	• Body, valve	1	
10	133 431	• Packing cartridge	1	
12	170 224	• Needle and seat, 3 mm	1	A
NS	170 225	• Needle and seat, 4 mm	1	B
NS	170 226	• Needle and seat, 5 mm	1	C
14	982 027	• Screw, skt. hd., M5 x 14	4	
NS	901 911	• Wrench, adjustment	2	
NS	901 905	Brush, nozzle	1	
—	900 458	Lubricant, rubber, 1 pint	1	
—	900 424	Compound, threadlock	1	

NOTE A: Used in part 170 509 and part 175 593, only

B: Used in part 170 510, only

C: Used in part 170 511, only

NS: Not Shown

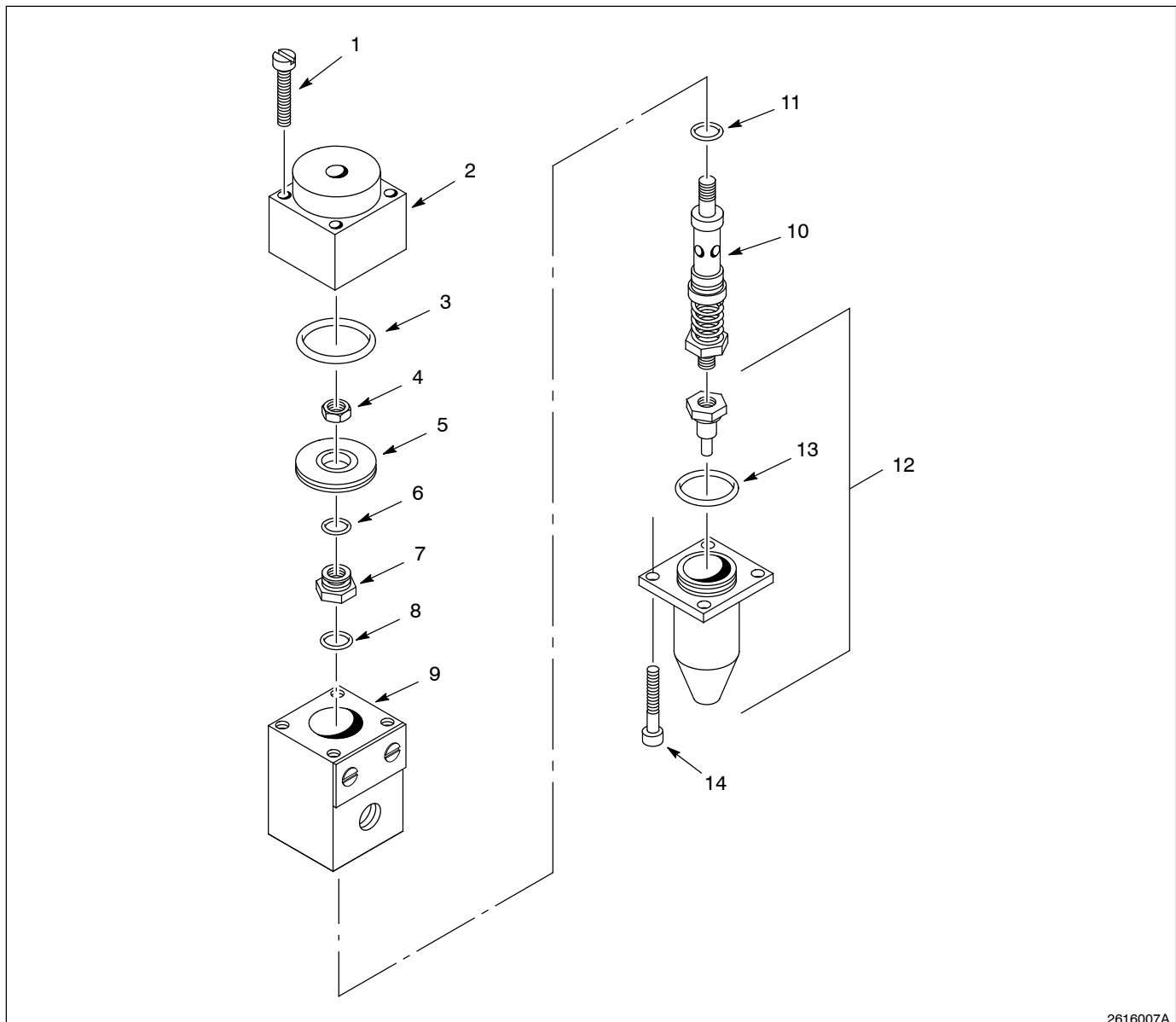

2616007A

Fig. 10 Zero-cavity automatic dispensing valve

O-ring Kit Parts List

See Figure 10.

Item	Part	Description
—	146 185	O-ring kit, zero-cavity dispensing valve
3	940 055	• O-ring, 1.428 ID x 0.063 W
6	940 090	• O-ring, 0.218 ID x 0.063 W
8	940 151	• O-ring, 0.563 ID x 0.063 W
11	940 133	• O-ring, 0.438 ID x 0.063 W
13	940 161	• O-ring, 0.625 ID x 0.063 W
NS	901 911	• Wrench, adjustment
NS: Not Shown		

9. Specifications**Dimensions**

Length 1.75 in. (44.45 mm)

Width 1.75 in. (44.45 mm)

Height 4.53 in. (115.06 mm)

Weight

15.1 oz (0.4198 kg)

Maximum Static Fluid Pressure Rating

4000 psi (275.87 bar)

Actuating Air Pressure

60–120 psi (4.14–8.38 bar)

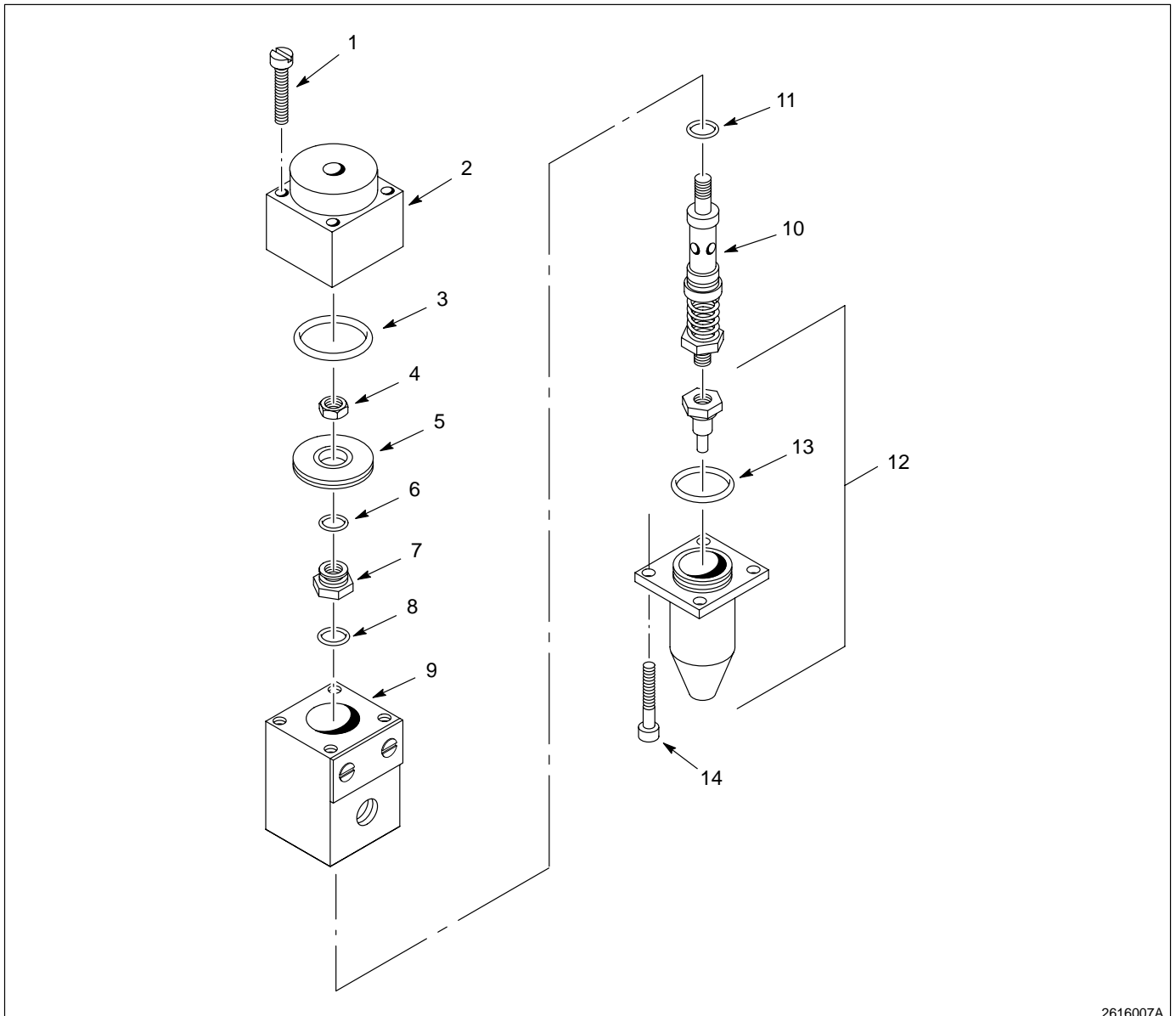

2616007A

Fig. 10 Zero-cavity automatic dispensing valve

O-ring Kit Parts List

See Figure 10.

Item	Part	Description
—	146 185	O-ring kit, zero-cavity dispensing valve
3	940 055	• O-ring, 1.428 ID x 0.063 W
6	940 090	• O-ring, 0.218 ID x 0.063 W
8	940 151	• O-ring, 0.563 ID x 0.063 W
11	940 133	• O-ring, 0.438 ID x 0.063 W
13	940 161	• O-ring, 0.625 ID x 0.063 W
NS	901 911	• Wrench, adjustment
NS: Not Shown		

9. Specifications**Dimensions**

Length 1.75 in. (44.45 mm)

Width 1.75 in. (44.45 mm)

Height 4.53 in. (115.06 mm)

Weight

15.1 oz (0.4198 kg)

Maximum Static Fluid Pressure Rating

4000 psi (275.87 bar)

Actuating Air Pressure

60–120 psi (4.14–8.38 bar)