

Section 11

Electrical System

NOTE: This section applies to applicators with C-style cordsets.

Table of Contents

Electrical System	11-1
Introduction	11-3
Overview of Electrical Operation	11-4
Cordsets	11-4
Adhesive Manifold Cordset	11-4
Heated Air Manifold Cordset	11-5
Heaters and Thermocouples	11-5
Thermostats	11-6
Cordset Connection	11-8
Preparing to Connect Cordsets	11-8
Connecting Adhesive Manifold Cordsets	11-9
Connecting Heated Air Manifold Cordsets	11-10
Restoring the System to Normal Operation	11-12
Disconnecting Cordsets	11-12
Cordset Service	11-14
Checking a Heater	11-14
Checking a Thermocouple	11-15
Checking a Thermostat	11-16
Replacing a Heater	11-18
Replacing a Thermocouple	11-20
Replacing a Thermostat	11-21
Resetting a Thermostat	11-22
Thermocouple Voltage Table	11-23
Parts	11-26
Adhesive Manifold Cordset	11-27
Heated Air Manifold Cordset	11-28
Splitter and Adapter Cables	11-29
Extension Cables	11-30
Recommended Spare Parts and Supplies	11-32
Technical Data	11-32
Electrical Specifications	11-32
Wiring Diagrams	11-32
Cordsets	11-33
Splitter and Adapter Cable Wiring Diagrams	11-34
Extension Cables	11-38

This page intentionally left blank.



WARNING: Allow only personnel with appropriate training and experience to operate or service the equipment. The use of untrained or inexperienced personnel to operate or service the equipment can result in injury, including death, to themselves and others, and damage to the equipment.

Introduction

This section describes the electrical system on applicators with Meltex thermocouple-style (hereafter referred to as C-style) cordsets. The applicator's electrical system includes the following components:

- adhesive manifold cordset(s) with heater(s) and thermocouple
- heated air manifold cordset(s) with heater(s) and thermocouple
- thermostats
- splitter and adapter cables (if used)
- extension cables

The hose also has some electrical components, including a cordset that connects it electrically to the melter and an electrical receptacle that connects it electrically to the applicator. In combination, the hose electrical connections, the applicator cordsets, and any cables used serve two purposes: (1) to supply electrical power to the heaters in the applicator adhesive and heated air manifolds and (2) to carry electrical signals from the thermocouples in the adhesive and heated air manifolds to a melter control system or to a standalone temperature controller. In addition, C-style adhesive manifold cordsets have two extra wires that may be used to supply power to one or more solenoid valves.

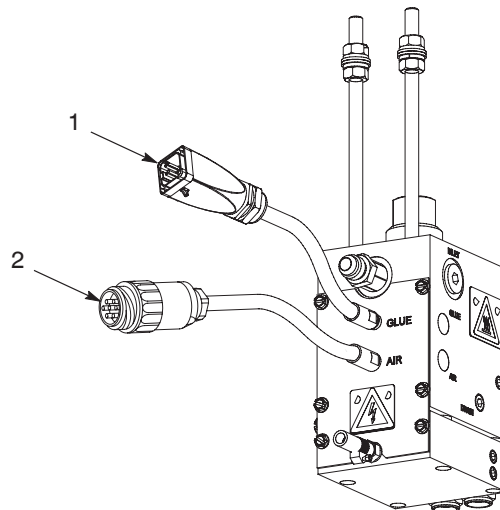

420400024

Figure 11-1 Applicator with C-style cordsets

1. Adhesive manifold cordset

2. Heated air manifold cordset

Overview of Electrical Operation

An applicator has two types of heated zone: adhesive manifold and heated air manifold. The adhesive manifold zones heat the adhesive in the applicator, and the heated air manifold zones heat the pattern air. Heating and temperature sensing of the zones is accomplished through cordsets.

Cordsets

Each heated zone has a cordset that is connected to one thermocouple and one or two heaters inside the applicator. Cordsets are then electrically connected, via a connector plug, to a temperature control channel on a melter control system or on a standalone temperature controller. The control system receives the thermocouple electrical signal and regulates the electrical power supplied to the heater(s) based on the signal. There are two types of cordset: adhesive manifold and heated air manifold.

Adhesive Manifold Cordset

See Figure 11-2. The adhesive manifold cordset has a square 8-pin male connector that connects to an 8-pin female connector on a hose or an extension, splitter, or adapter cable. The adhesive manifold cordset also has two extra wires that may supply power to one or more solenoid valves.

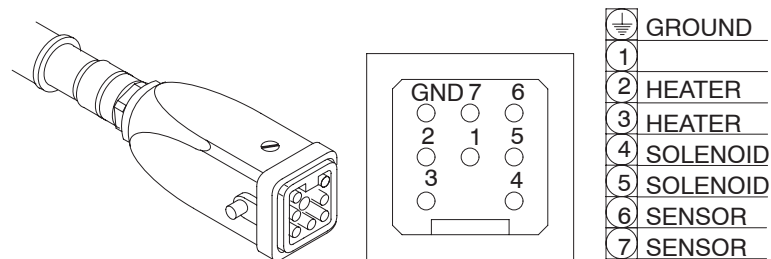

690300004

Figure 11-2 C-style adhesive manifold cordset connector

Heated Air Manifold Cordset

See Figure 11-3. The heated air manifold cordset has a round 7-pin male connector that connects to a 7-pin female connector on an extension, splitter, or adapter cable.

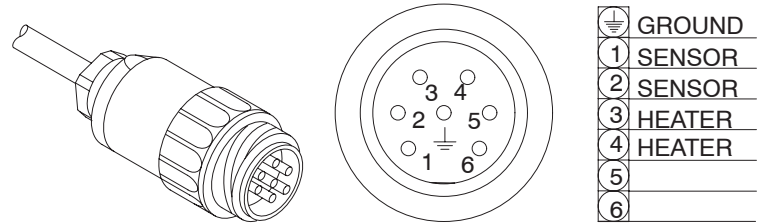

69030008

Figure 11-3 C-style heated air manifold cordset connector

Heaters and Thermocouples

Cordsets are wired to a replaceable cartridge heater (or heaters) housed in a bore inside each adhesive and heated air manifold zone, as shown in Figure 11-9 later in this section. When power is supplied to a heater, it heats the adhesive or the pattern air in the applicator manifolds. Two heaters are present when a zone's heating requirements are higher. Typically, the heating requirements of a filtered applicator are greater than those of a non-filtered applicator and the heating requirements of heated air manifold zones are greater than the heating requirements of adhesive manifold zones.

Cordsets are also wired to a thermocouple housed in a bore in each adhesive and heated air manifold zone. A thermocouple is an electronic temperature control device in which the voltage, in millivolts, varies depending on the temperature of the device. The thermocouple relays the temperature of the manifold to a melter control system or to a temperature controller, which in turn adjusts the power supplied to the manifold heaters accordingly.

NOTE: On some applicators, the thermocouple is an integral part of the cordset wiring (in which case no wire nut or connector is used).

Thermostats

Each adhesive manifold on the applicator has a thermostat that is connected in series with the heater(s) as shown in Figure 11-9 later in this section. Thermostats provides additional overtemperature protection. Normally, the control system maintains the temperature in a heated zone based on the voltage of the thermocouple. However, if the thermocouple fails, the thermostat acts as a backup, preventing the temperature in that heated zone from rising above its setpoint.

During normal operation, when the applicator temperature is below its setpoint, the thermostat should be closed, allowing power to reach the heaters. If the applicator does not heat properly and the applicator temperature has not been above the setpoint temperature, a thermostat may have failed.

If the applicator temperature rises above the thermostat setpoint, the thermostat has failed. The system should be shut down and the thermostat checked and replaced as necessary. The setpoint temperature for the thermostat is 260 °C (500 °F).

This page intentionally left blank.

Cordset Connection

Cordsets must be properly connected to hoses and/or splitter and extension cables to supply power to the applicator. This part of Section 11 provides cordset connection procedures for an installation in which adhesive manifold cordsets are connected to hose connectors and to extension and adapter cables and in which heated air manifold cordsets are connected to heated air manifold extension and splitter or adapter cables, which is the recommended configuration. If you need assistance with cordset installation, contact your Nordson representative.

NOTE: Normally, the hose, cordset, and cable configuration of your system will have already been determined by you and your Nordson representative. If you need to change the configuration, contact your Nordson representative for assistance. Splitter, adapter, and extension cable part numbers are provided in *Parts* at the end of this section.



WARNING: Risk of personal injury or death. Allow only qualified personnel to perform electrical installation, troubleshooting, or repair procedures. Before performing any electrical procedure, review Section 1, *Safety*, and disconnect and lock out electrical power to the system.

Preparing to Connect Cordsets

1. If the system is in operation, relieve system pressure. Refer to *Relieving System Pressure* in Section 10, *Filter*.
2. Disconnect and lock out electrical power to the system.

Connecting Adhesive Manifold Cordsets

Connect adhesive manifold cordsets as appropriate for your application. Refer to Table 11-1 and Figure 11-4 for a typical installation configuration

Table 11-1 Typical Adhesive Manifold Cordset Connections

Item in Figure 11-4	Component	Connect to...
1	First adhesive manifold cordset	Extension cable (item 2)
2	Extension cable	First adhesive manifold cordset (item 1) and to adapter cable (item 3)
3	Adapter cable	Extension cable (item 2) and to electrical receptacle on melter (item 6)
4	Second adhesive manifold cordset	Hose connector
5	Hose cordset	Electrical receptacle on melter (item 6)

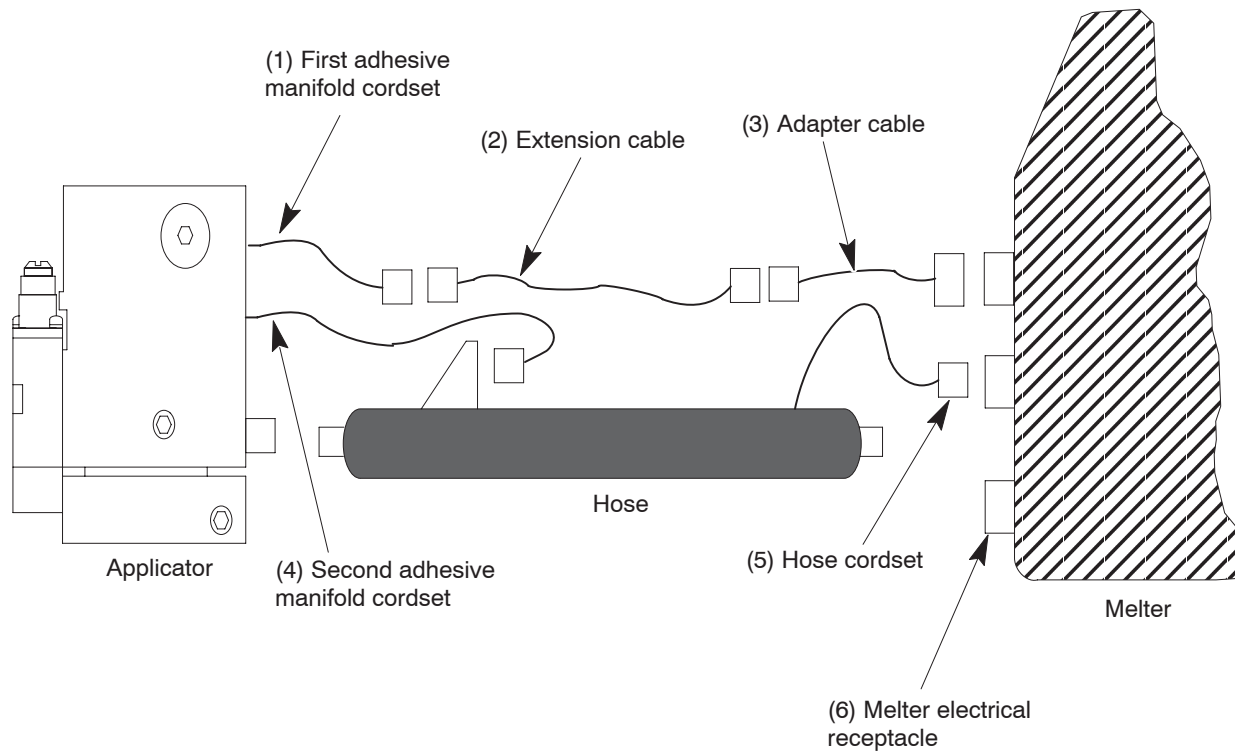

Figure 11-4 Typical adhesive manifold cordset connections

- | | | |
|------------------------------------|-------------------------------------|---------------------------------|
| 1. First adhesive manifold cordset | 3. Adapter cable | 5. Hose cordset |
| 2. Extension cable | 4. Second adhesive manifold cordset | 6. Melter electrical receptacle |

Connecting Heated Air Manifold Cordsets

Connect heated air manifold cordsets as appropriate for your application. Refer to Table 11-2 and Figure 11-5 for a typical installation configuration.

Table 11-2 Typical Heated Air Manifold Cordset Connections

Item in Figure 11-5	Component	Connect to...
1	One air manifold cordset	Extension cable (item 2)
2	Extension cable	One air manifold cordset (item 1) and adapter cable (item 3)
3	Adapter cable	Extension cable (item 2) and electrical receptacle on melter (item 7)
4	Two air manifold cordsets	Extension cables (item 5)
5	Extension cables	Two air manifold cordsets (item 4) and splitter cable (item 6)
6	Splitter cable	Extension cables (item 5) and electrical receptacle on melter (item 7)

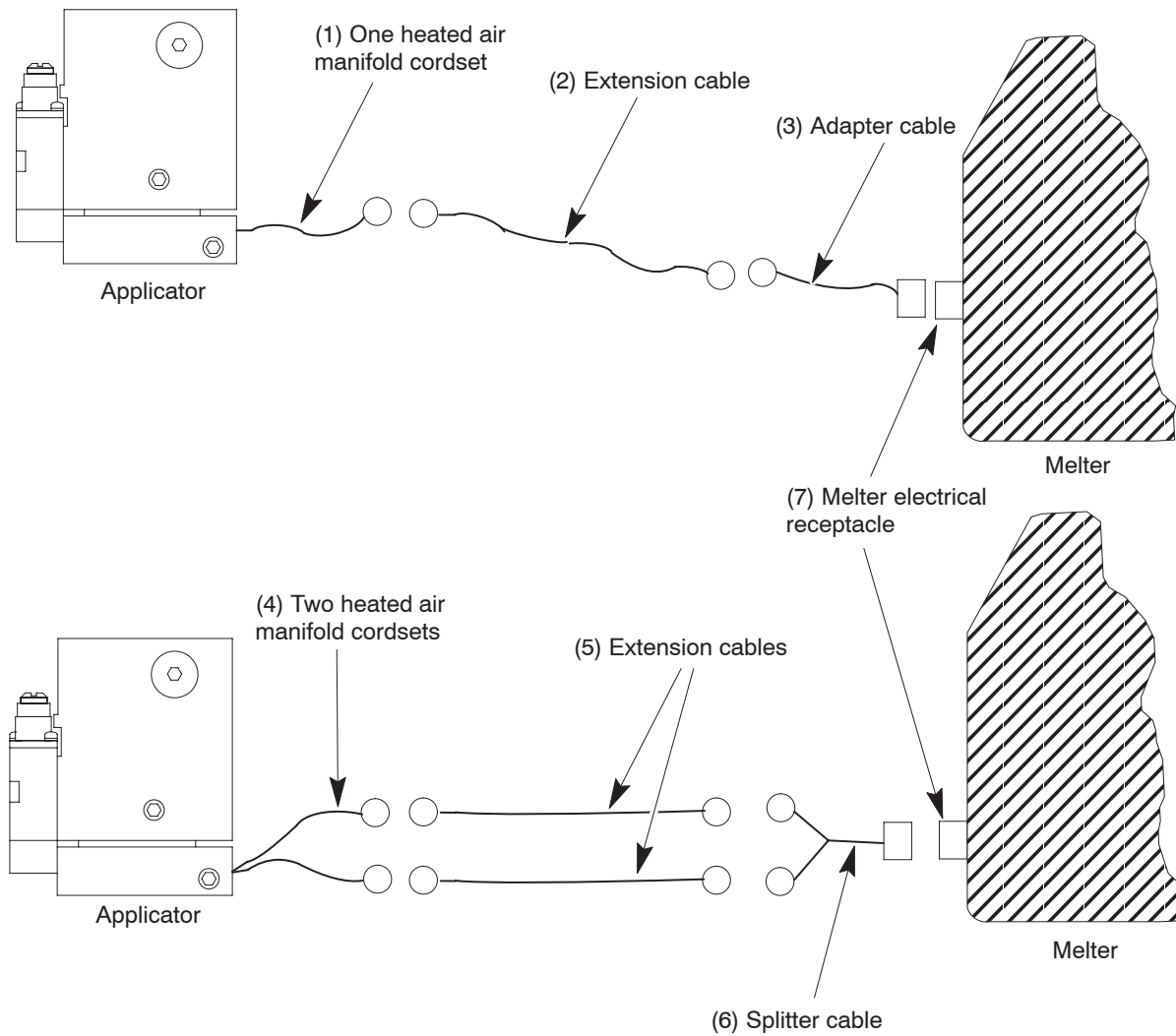

Figure 11-5 Typical heated air manifold cordset connections

- | | | |
|------------------------------------|-------------------------------------|---------------------------------|
| 1. One heated air manifold cordset | 4. Two heated air manifold cordsets | 6. Splitter cable |
| 2. Extension cable | 5. Extension cables | 7. Melter electrical receptacle |
| 3. Adapter cable | | |

Restoring the System to Normal Operation

Perform whichever of the following steps is appropriate for your installation:

- If the cordsets were connected as part of the initial installation of the applicator, return to the applicator installation procedures in Section 3, *Installation*, to complete the installation.
- If the cordsets were connected as part of another procedure, return to that procedure.
- If applicable, restore the system to normal operation. Refer to *Starting the Applicator* in Section 4, *Operation*, as needed.

Disconnecting Cordsets

Before disconnecting any cordset, relieve system pressure and disconnect and lock out electrical power to the system. Refer to *Relieving System Pressure* in Section 10, *Filter*, as needed.

This page intentionally left blank.

Cordset Service

This part of Section 11 provides cordset-related service procedures.



WARNING: Risk of personal injury or death. Allow only qualified personnel to perform electrical installation, troubleshooting, or repair procedures. Before performing any electrical procedure, review Section 1, *Safety*, and disconnect and lock out electrical power to the system.

Checking a Heater

1. Relieve system pressure. Refer to *Relieving System Pressure* in Section 10, *Filter*.
2. Disconnect and lock out electrical power to the system.
3. Disconnect the cordset that supplies power to the heater to be checked.
4. See Figure 11-6 or 11-7 as appropriate. Use an ohmmeter to check the heater resistance and continuity at the heater pins on the cordset:
 - If you measure low resistance, the heaters are operating normally. Return to the procedure that referenced this check.
 - If you measure high resistance or if an open circuit is indicated, there may be a broken wire, a loose connection, or a defective heater. Continue to the next step.

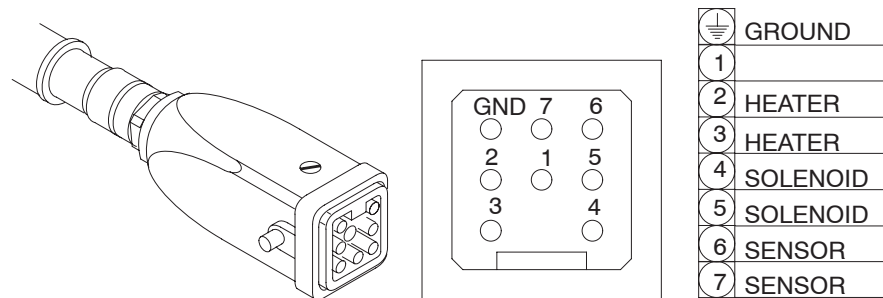

690300004

Figure 11-6 C-style adhesive manifold cordset connector

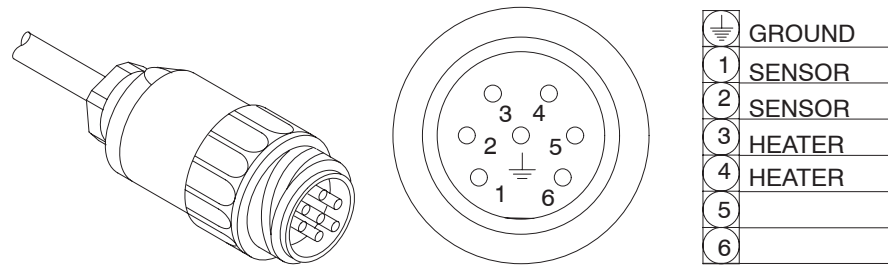

690300008

Figure 11-7 C-style heated air manifold cordset connector

5. Remove the appropriate manifold cover and inspect the heater wiring. Make sure there are no broken wires or loose connections and that the heaters are wired correctly. Refer to the cordset wiring diagrams provided in *Applicator-Specific Reference Drawings* in Section 8, *Parts*, as needed:
 - If any wiring problems are found, correct the problems and restore the system to normal operation.
 - If no wiring problems are found, the heater is probably defective. Replace the heater. Refer to *Replacing a Heater* later in this section.

Checking a Thermocouple

NOTE: You will need to know the temperature of the thermocouple to properly perform this check.

1. Relieve system pressure. Refer to *Relieving System Pressure* in Section 10, *Filter*.
2. Disconnect and lock out electrical power to the system.
3. Disconnect the cordset that supplies power to the thermocouple to be checked.
4. See Figure 11-6 or 11-7 as appropriate. With the thermocouple at a known temperature, use a millivoltmeter to check the thermocouple voltage between the thermocouple pins on the cordset.
5. Refer to *Thermocouple Voltage Table* later in this section to determine whether the measured value is the normal value for that temperature:
 - If the measured voltage is correct, the thermocouple is operating properly. Return to the procedure that referenced this check.
 - If the measured voltage is not correct, replace the thermocouple. Refer to *Replacing a Thermocouple* later in this section.

Checking a Thermostat

NOTE: Thermostats fail in the open position.

1. Relieve system pressure. Refer to *Relieving System Pressure* in Section 5, *Maintenance*.
2. Disconnect and lock out electrical power to the system.
3. Disconnect the cordset that supplies power to the thermostat to be checked.
4. See Figure 11-8. With the applicator at or below the adhesive application temperature, use an ohmmeter to measure the resistance between the heater pins on the adhesive manifold cordset:
 - If the measured resistance does not indicate an open circuit, the thermostat is operating properly at the normal operating temperature. Return to the procedure that referenced this check.
 - If the measured resistance indicates an open circuit, the thermostat may have failed. Proceed to the next step.

NOTE: When the applicator is at or below the adhesive application temperature, the thermostat should be closed.

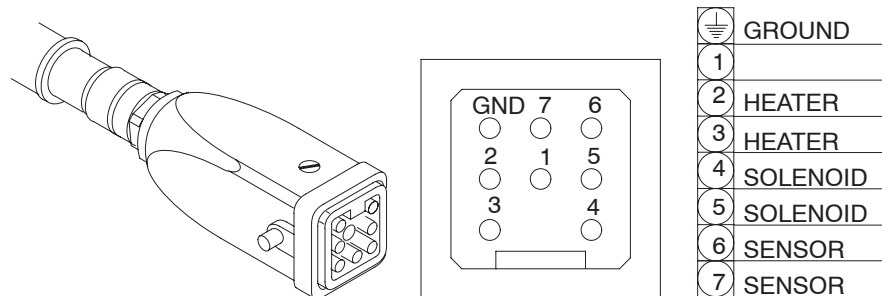

690300004

Figure 11-8 C-style adhesive manifold cordset connector

5. Remove the adhesive manifold cover and locate the wiring for the thermostat and the heater. Inspect the wiring and wire nuts for loose connections or damage. If loose or damaged connections are found or if damaged wiring is found, tighten the connections or repair the damage.

6. Use an ohmmeter to check the continuity of the thermostat circuit by placing the ohmmeter probes on the thermostat wiring connectors:
 - If the measured resistance indicates a short circuit, the thermostat is operating properly. Reinstall the manifold cover, reconnect the cordset, and return to the procedure that referenced this check.
 - If the measured resistance indicates an open circuit, the thermostat is open. Proceed to the next step.
7. Attempt to reset the thermostat by pressing the reset button on the thermostat.
8. Check the resistance again:
 - If the measured resistance indicates a short circuit, the thermostat is operating properly. Reinstall the manifold cover, reconnect the cordset, and return to the procedure that referenced this check.
 - If the measured resistance indicates an open circuit, the thermostat has failed. Replace the thermostat. Refer to the next procedure, *Replacing a Thermostat*.

Replacing a Heater

You will need the following items:

- appropriate tools
- small rod for loosening the heater (if needed)
- replacement heater
- replacement wire nuts or terminal blocks (if needed)
- heater lubricant

1. Relieve system pressure. Refer to *Relieving System Pressure* in Section 10, *Filter*.
2. Disconnect and lock out electrical power to the system.
3. Disconnect the cordset that supplies power to the heater to be replaced.
4. Remove the appropriate manifold cover. Refer to the applicator reference drawing provided in *Applicator-Specific Reference Drawings* in Section 8, *Parts*, as needed.
5. Disconnect the heater wires from the cordset wires.
6. See Figure 11-9. Remove the heater from the manifold.

NOTE: If the heater does not easily slide out of its bore, locate the small access hole at the back of the heater. Insert a small rod in the access hole and gently push or tap on the rod to loosen the heater.

7. Coat a new heater with heater lubricant and insert it into the bore in the manifold.
8. Connect the new heater wires to the cordset heater wires. Refer to the cordset wiring diagrams provided in *Applicator-Specific Reference Drawings* in Section 8, *Parts*, as needed.

NOTE: The heater wires are not polarity-sensitive. Either heater wire can be connected to either cordset wire.

9. Reinstall the manifold cover, reconnect the cordset, and restore the system to normal operation.

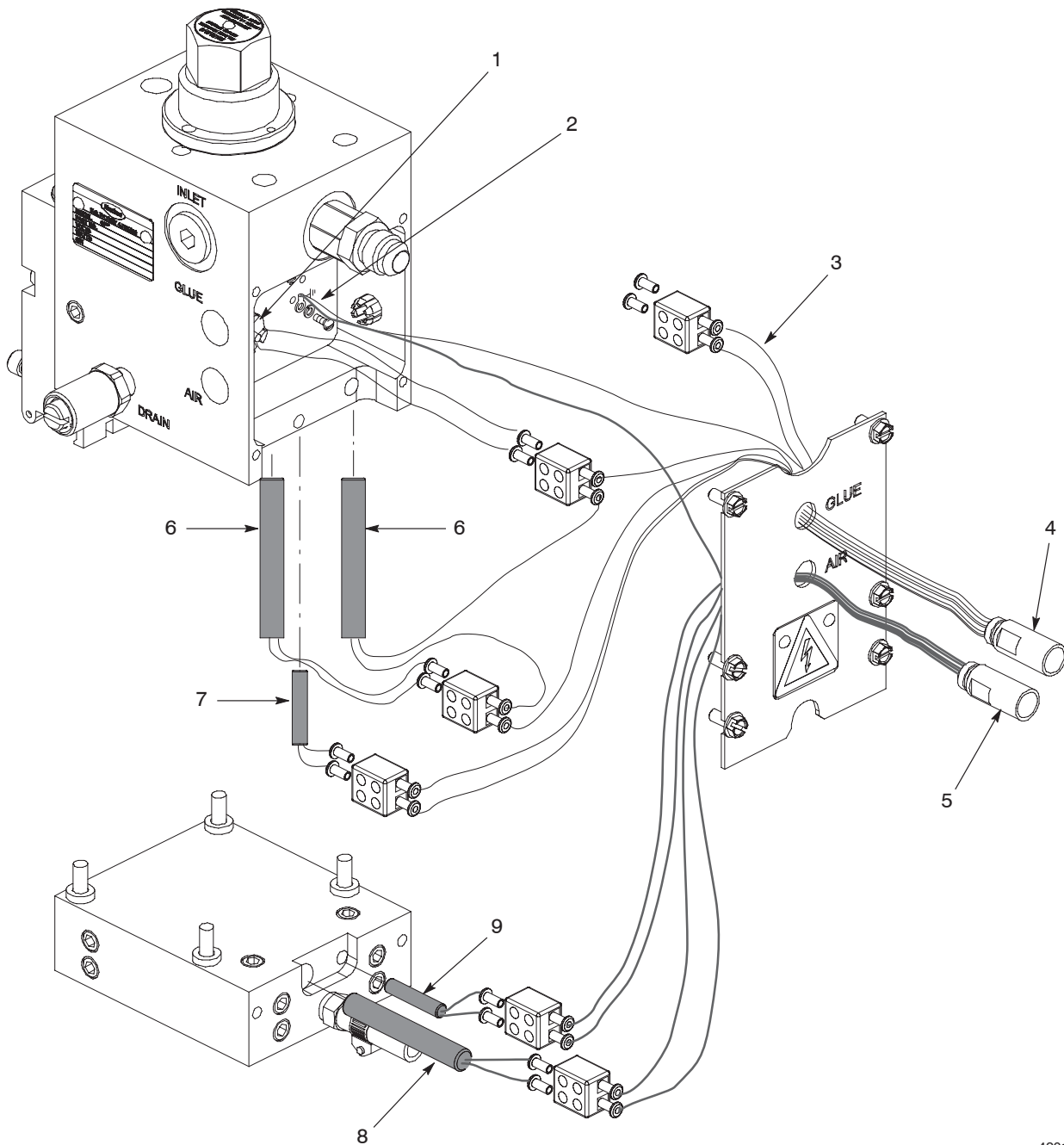

420100032

Figure 11-9 Typical configuration of heaters and thermocouple (applicator with vertical filter and two heaters shown)

- | | | |
|--|-------------------------------------|---------------------------------------|
| 1. Thermostat connection | 4. Adhesive manifold cordset | 8. Heater (heated air manifold) |
| 2. Ground connection | 5. Heated air manifold cordset | 9. Thermocouple (heated air manifold) |
| 3. Solenoid wires (refer to solenoid valve wiring diagram if applicable) | 6. Heater (adhesive manifold) | |
| | 7. Thermocouple (adhesive manifold) | |

Replacing a Thermocouple

You will need the following items:

- appropriate tools, including a wire stripper and cutter
 - replacement thermocouple
 - replacement wire nuts or terminal blocks (if needed)
1. Relieve system pressure. Refer to *Relieving System Pressure* in Section 10, *Filter*.
 2. Disconnect and lock out electrical power to the system.
 3. Disconnect the cordset that supplies power to the thermocouple to be replaced.
 4. Remove the adhesive manifold cover. Refer to the applicator reference drawing provided in *Applicator-Specific Reference Drawings* in Section 8, *Parts*, as needed.
 5. Note the color of the wires connected to the thermocouple pins on the cordset; then disconnect the thermocable from the those wires and remove it from the applicator. See Figure 11-6 or 11-7 as appropriate.
 6. Thread one end of the new thermocable through the cordset flexible conduit; then connect the thermocable wires to the wires connected to the thermocouple pins on the cordset, matching the wires to the pins by wire color.
 7. At the other end of the thermocable, strip about 2.5 cm (1 in.) of insulation off both wires.
 8. Twist the two sections of bare wire together so that secure contact is made between the wires.
 9. Clip the section of bare wire twisted together so that it is about 0.5 cm–1.0 cm (0.25–0.50 in.) long.
 10. Insert the thermocable into the thermocouple and tighten the set screw to secure the thermocable.
 11. Coat a new thermocouple with heater lubricant and insert it into the bore in the manifold.
 12. Reinstall the manifold cover, reconnect cordsets, and restore the system to normal operation.

Replacing a Thermostat

You will need the following items:

- appropriate tools
 - replacement thermostat
 - replacement wire nuts or terminal blocks (if needed)
1. Relieve system pressure. Refer to *Relieving System Pressure* in Section 5, *Maintenance*.
 2. Disconnect and lock out electrical power to the system.
 3. Remove the adhesive manifold cover and locate the thermostat and heater wiring. Refer to the applicator reference drawing provided in *Applicator-Specific Reference Drawings* in Section 8, *Parts*, as needed.
 4. Loosen the wire nuts that connect the wiring to the thermostat, remove the thermostat screws, and remove the thermostat from the manifold.
 5. Place the new thermostat in the mount, secure it with the thermostat screws, and connect the thermostat wiring to the cordset and heater wiring with the wire nuts. Refer to the adhesive manifold cordset wiring diagram in *Applicator-Specific Reference Drawings* in Section 8, *Parts*.
 6. Reinstall the adhesive manifold cover, reconnect the cordset, and restore the system to normal operation.

Resetting a Thermostat

When an adhesive manifold thermostat opens because of an overtemperature condition, it must be manually reset before the applicator can be restored to normal operation.

1. Relieve system pressure. Refer to *Relieving System Pressure* in Section 5, *Maintenance*.
2. Disconnect and lock out electrical power to the system.
3. Remove the appropriate adhesive manifold cover. Refer to the applicator reference drawing provided in *Applicator-Specific Reference Drawings* in Section 8, *Parts*, as needed.
4. See Figure 11-10. Press the reset button on the thermostat.
5. Reinstall the manifold cover and restore the system to normal operation.
6. If the thermostat still does not operate properly, go to *Checking a Thermostat* earlier in this section.

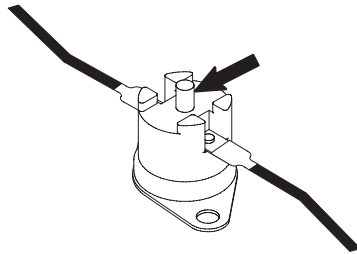

Figure 11-10 Location of the reset button on a thermostat

Thermocouple Voltage Table

Table 11-3 lists thermocouple voltage as a function of temperature. Refer to *Checking a Thermocouple* earlier in this section for the procedure for checking a thermocouple.

Table 11-3 Thermocouple Voltage as a Function of Temperature

Temperature		Voltage	Temperature		Voltage
18 °C	64.4 °F	0.94 mV	46 °C	114.8 °F	2.43 mV
19 °C	66.2 °F	1.00 mV	47 °C	116.6 °F	2.49 mV
20 °C	68.0 °F	1.05 mV	48 °C	118.4 °F	2.54 mV
21 °C	69.8 °F	1.10 mV	49 °C	120.2 °F	2.60 mV
22 °C	71.6 °F	1.16 mV	50 °C	122 °F	2.65 mV
23 °C	73.4 °F	1.21 mV	51 °C	123.8 °F	2.70 mV
24 °C	75.2 °F	1.26 mV	52 °C	125.6 °F	2.76 mV
25 °C	77.0 °F	1.31 mV	53 °C	127.4 °F	2.81 mV
26 °C	78.8 °F	1.37 mV	54 °C	129.2 °F	2.87 mV
27 °C	80.6 °F	1.42 mV	55 °C	131 °F	2.92 mV
28 °C	82.4 °F	1.47 mV	56 °C	132.8 °F	2.97 mV
29 °C	84.2 °F	1.53 mV	57 °C	134.6 °F	3.03 mV
30 °C	86.0 °F	1.58 mV	58 °C	136.4 °F	3.08 mV
31 °C	87.8 °F	1.63 mV	59 °C	138.2 °F	3.14 mV
32 °C	89.6 °F	1.69 mV	60 °C	140 °F	3.19 mV
33 °C	91.4 °F	1.74 mV	61 °C	141.8 °F	3.24 mV
34 °C	93.2 °F	1.79 mV	62 °C	143.6 °F	3.30 mV
35 °C	95.0 °F	1.84 mV	63 °C	145.4 °F	3.35 mV
36 °C	96.8 °F	1.90 mV	64 °C	147.2 °F	3.41 mV
37 °C	98.6 °F	1.95 mV	65 °C	149 °F	3.46 mV
38 °C	100.4 °F	2.00 mV	66 °C	150.8 °F	3.51 mV
39 °C	102.2 °F	2.06 mV	67 °C	152.6 °F	3.57 mV
40 °C	104.0 °F	2.11 mV	68 °C	154.4 °F	3.62 mV
41 °C	105.8 °F	2.16 mV	69 °C	156.2 °F	3.68 mV
42 °C	107.6 °F	2.22 mV	70 °C	158 °F	3.73 mV
43 °C	109.4 °F	2.27 mV	71 °C	159.8 °F	3.78 mV
44 °C	111.2 °F	2.33 mV	72 °C	161.6 °F	3.84 mV
45 °C	113.0 °F	2.38 mV	73 °C	163.4 °F	3.89 mV
74 °C	165.2 °F	3.95 mV	102 °C	215.6 °F	5.48 mV
75 °C	167.0 °F	4.00 mV	103 °C	217.4 °F	5.53 mV
76 °C	168.8 °F	4.05 mV	104 °C	219.2 °F	5.59 mV
77 °C	170.6 °F	4.11 mV	105 °C	221.0 °F	5.64 mV
78 °C	172.4 °F	4.16 mV	106 °C	222.8 °F	5.70 mV
79 °C	174.2 °F	4.22 mV	107 °C	224.6 °F	5.75 mV
80 °C	176.0 °F	4.27 mV	108 °C	226.4 °F	5.81 mV
81 °C	177.8 °F	4.32 mV	109 °C	228.2 °F	5.87 mV
82 °C	179.6 °F	4.38 mV	110 °C	230.0 °F	5.92 mV
83 °C	181.4 °F	4.43 mV	111 °C	231.8 °F	5.97 mV
84 °C	183.2 °F	4.49 mV	112 °C	233.6 °F	6.03 mV
85 °C	185.0 °F	4.54 mV	113 °C	235.4 °F	6.08 mV
86 °C	186.8 °F	4.60 mV	114 °C	237.2 °F	6.14 mV
87 °C	188.6 °F	4.65 mV	115 °C	239.0 °F	6.19 mV
88 °C	190.4 °F	4.71 mV	116 °C	240.8 °F	6.25 mV
89 °C	192.2 °F	4.77 mV	117 °C	242.6 °F	6.30 mV
90 °C	194.0 °F	4.82 mV	118 °C	244.4 °F	6.36 mV
91 °C	195.8 °F	4.87 mV	119 °C	246.2 °F	6.42 mV

Continued on next page

Thermocouple Voltage Table *(contd)*

Table 11-3 Thermocouple Voltage as a Function of Temperature *(contd)*

Temperature		Voltage	Temperature		Voltage
92 °C	197.6 °F	4.93 mV	120 °C	248.0 °F	6.47 mV
93 °C	199.4 °F	4.98 mV	121 °C	249.8 °F	6.53 mV
94 °C	201.2 °F	5.04 mV	122 °C	251.6 °F	6.58 mV
95 °C	203.0 °F	5.09 mV	123 °C	253.4 °F	6.64 mV
96 °C	204.8 °F	5.15 mV	124 °C	255.2 °F	6.69 mV
97 °C	206.6 °F	5.20 mV	125 °C	257.0 °F	6.75 mV
98 °C	208.4 °F	5.26 mV	126 °C	258.8 °F	6.81 mV
99 °C	210.2 °F	5.32 mV	127 °C	260.6 °F	6.86 mV
100 °C	212.0 °F	5.37 mV	128 °C	262.4 °F	6.92 mV
101 °C	213.8 °F	5.42 mV	129 °C	264.2 °F	6.97 mV
130 °C	266.0 °F	7.03 mV	158 °C	316.4 °F	8.60 mV
131 °C	267.8 °F	7.09 mV	159 °C	318.2 °F	8.65 mV
132 °C	269.6 °F	7.14 mV	160 °C	320.0 °F	8.71 mV
133 °C	271.4 °F	7.20 mV	161 °C	321.8 °F	8.77 mV
134 °C	273.2 °F	7.25 mV	162 °C	323.6 °F	8.82 mV
135 °C	275.0 °F	7.31 mV	163 °C	325.4 °F	8.88 mV
136 °C	276.8 °F	7.37 mV	164 °C	327.2 °F	8.93 mV
137 °C	278.6 °F	7.42 mV	165 °C	329.0 °F	8.99 mV
138 °C	280.4 °F	7.48 mV	166 °C	330.8 °F	9.05 mV
139 °C	282.2 °F	7.53 mV	167 °C	332.6 °F	9.10 mV
140 °C	284.0 °F	7.59 mV	168 °C	334.4 °F	9.16 mV
141 °C	285.8 °F	7.65 mV	169 °C	336.2 °F	9.21 mV
142 °C	287.6 °F	7.70 mV	170 °C	338.0 °F	9.27 mV
143 °C	289.4 °F	7.76 mV	171 °C	339.8 °F	9.33 mV
144 °C	291.2 °F	7.81 mV	172 °C	341.6 °F	9.38 mV
145 °C	293.0 °F	7.87 mV	173 °C	343.4 °F	9.44 mV
146 °C	294.8 °F	7.93 mV	174 °C	345.2 °F	9.49 mV
147 °C	296.6 °F	7.98 mV	175 °C	347.0 °F	9.55 mV
148 °C	298.4 °F	8.04 mV	176 °C	348.8 °F	9.61 mV
149 °C	300.2 °F	8.09 mV	177 °C	350.6 °F	9.66 mV
150 °C	302.0 °F	8.15 mV	178 °C	352.4 °F	9.72 mV
151 °C	303.8 °F	8.21 mV	179 °C	354.2 °F	9.77 mV
152 °C	305.6 °F	8.26 mV	180 °C	356.0 °F	9.83 mV
153 °C	307.4 °F	8.32 mV	181 °C	357.8 °F	9.89 mV
154 °C	309.2 °F	8.37 mV	182 °C	359.6 °F	9.94 mV
155 °C	311.0 °F	8.43 mV	183 °C	361.4 °F	10.00 mV
156 °C	312.8 °F	8.49 mV	184 °C	363.2 °F	10.05 mV
157 °C	314.6 °F	8.54 mV	185 °C	365.0 °F	10.11 mV
186 °C	366.8 °F	10.17 mV	214 °C	417.2 °F	11.73 mV
187 °C	368.6 °F	10.22 mV	215 °C	419.0 °F	11.79 mV
188 °C	370.4 °F	10.28 mV	216 °C	420.8 °F	11.85 mV
189 °C	372.2 °F	10.33 mV	217 °C	422.6 °F	11.90 mV
190 °C	374.0 °F	10.39 mV	218 °C	424.4 °F	11.96 mV
191 °C	375.8 °F	10.45 mV	219 °C	426.2 °F	12.01 mV
192 °C	377.6 °F	10.50 mV	220 °C	428.0 °F	12.07 mV
193 °C	379.4 °F	10.56 mV	221 °C	429.8 °F	12.13 mV
194 °C	381.2 °F	10.61 mV	222 °C	431.6 °F	12.18 mV
195 °C	383.0 °F	10.67 mV	223 °C	433.4 °F	12.24 mV
196 °C	384.8 °F	10.73 mV	224 °C	435.2 °F	12.29 mV
197 °C	386.6 °F	10.78 mV	225 °C	437.0 °F	12.35 mV
198 °C	388.4 °F	10.84 mV	226 °C	438.8 °F	12.41 mV

Continued on next page

Table 11-3 Thermocouple Voltage as a Function of Temperature (contd)

Temperature		Voltage	Temperature		Voltage
199 °C	390.2 °F	10.89 mV	227 °C	440.6 °F	12.46 mV
200 °C	392.0 °F	10.95 mV	228 °C	442.4 °F	12.52 mV
201 °C	393.8 °F	11.01 mV	229 °C	444.2 °F	12.57 mV
202 °C	395.6 °F	11.06 mV	230 °C	446.0 °F	12.63 mV
203 °C	397.4 °F	11.12 mV	231 °C	447.8 °F	12.69 mV
204 °C	399.2 °F	11.17 mV	232 °C	449.6 °F	12.74 mV
205 °C	401.0 °F	11.23 mV	233 °C	451.4 °F	12.80 mV
206 °C	402.8 °F	11.29 mV	234 °C	453.2 °F	12.85 mV
207 °C	404.6 °F	11.34 mV	235 °C	455.0 °F	12.91 mV
208 °C	406.4 °F	11.40 mV	236 °C	456.8 °F	12.97 mV
209 °C	408.2 °F	11.45 mV	237 °C	458.6 °F	13.02 mV
210 °C	410.0 °F	11.51 mV	238 °C	460.4 °F	13.08 mV
211 °C	411.8 °F	11.57 mV	239 °C	462.2 °F	13.13 mV
212 °C	413.6 °F	11.62 mV	240 °C	464.0 °F	13.19 mV
213 °C	415.4 °F	11.68 mV	241 °C	465.8 °F	13.25 mV
242 °C	467.6 °F	13.30 mV			
243 °C	469.4 °F	13.36 mV			
244 °C	471.2 °F	13.41 mV			
245 °C	473.0 °F	13.47 mV			
246 °C	474.8 °F	13.53 mV			
247 °C	476.6 °F	13.58 mV			
248 °C	478.4 °F	13.64 mV			
249 °C	480.2 °F	13.69 mV			
250 °C	482.0 °F	13.75 mV			
251 °C	483.8 °F	13.81 mV			
252 °C	485.6 °F	13.86 mV			
253 °C	487.4 °F	13.92 mV			
254 °C	489.2 °F	13.97 mV			
255 °C	491.0 °F	14.03 mV			
256 °C	492.8 °F	14.09 mV			
257 °C	494.6 °F	14.14 mV			
258 °C	496.4 °F	14.20 mV			
259 °C	498.2 °F	14.25 mV			
260 °C	500.0 °F	14.31 mV			

Parts

This part of Section 11 provides detailed parts lists for the electrical system. For other applicator parts, including a reference drawing and bill of materials specific to your applicator, refer to Section 8, *Parts*. The following chart provides guidance for reading the parts lists.

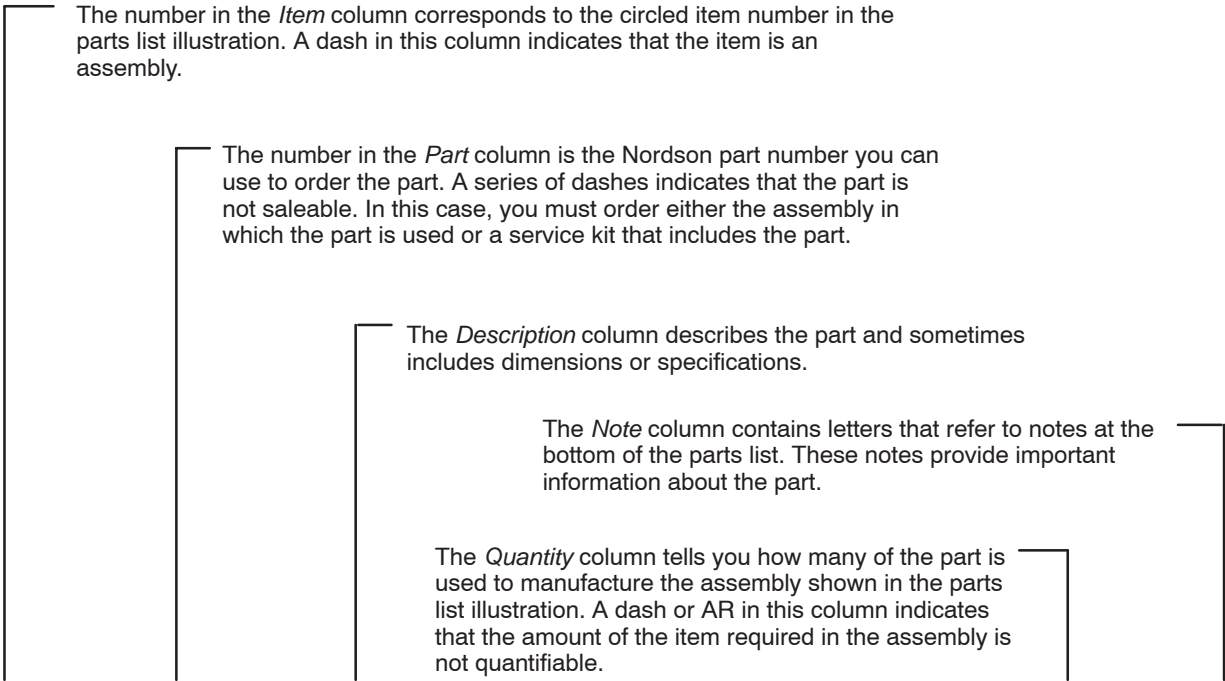

Item	Part	Description	Quantity	Note
—	0000000	Assembly A	—	
1	000000	• Part of assembly A	2	A
2	-----	•• Part of item 1	1	
3	0000000	••• Part of item 2	AR	
NS	000000	•••• Part of item 3	2	
NOTE A: Important information about item 1				
AR: As Required				
NS: Not Shown				

Adhesive Manifold Cordset

See Figure 11-11.

Part	Description	Note
158474	Cordset, adhesive manifold, C-style, thermocouple, 7-wire	

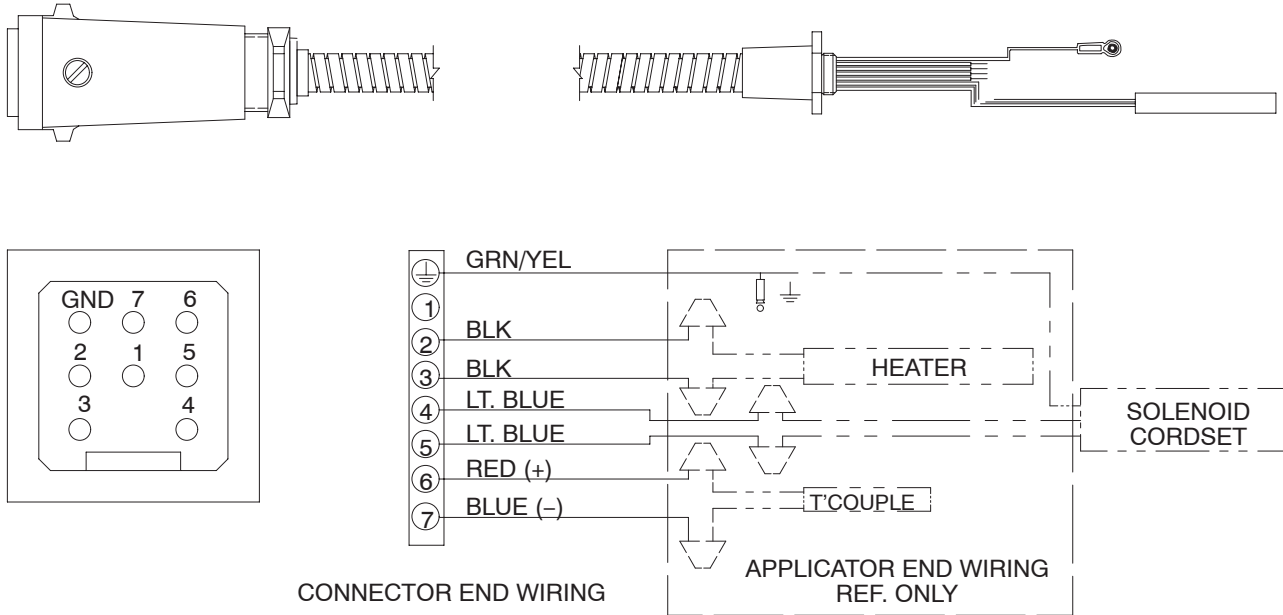

Figure 11-11 C-style adhesive manifold cordset

Heated Air Manifold Cordset

See Figure 11-12.

Part	Description	Note
152126	Cordset, heated air manifold, C-style, thermocouple, 5-wire	

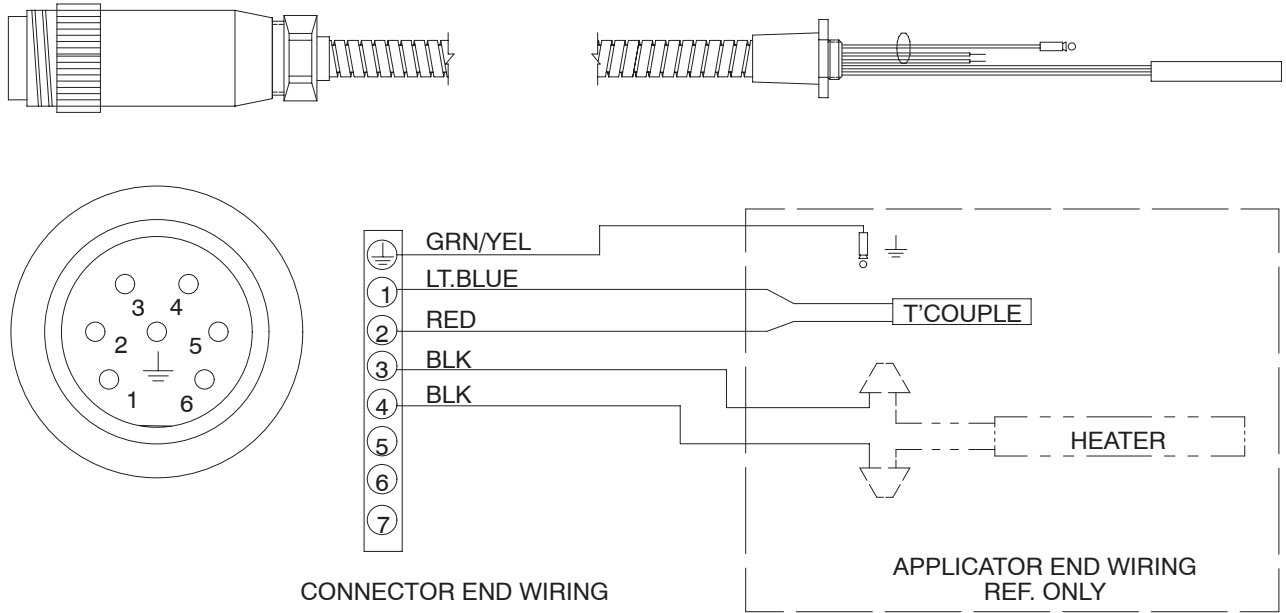

Figure 11-12 C-style heated air manifold cordset

Splitter and Adapter Cables

See Figure 11-13. These splitter and adapter cables can be used to connect the cordsets on hoses and applicators to the electrical receptacles on the melter. In most cases, extension cables will be needed.

Item	Part	Description	Quantity	Note
1	289764	Splitter cable, C-style, 2 heated air manifold cordsets, 0.3 m	AR	
2	289153	Splitter cable, C-style, 1 adhesive manifold cordset and 1 heated air manifold cordset, 0.3 m	AR	
3	289762	Splitter cable, C-style, 2 adhesive manifold cordsets, 0.3 m	AR	
4	289763	Adapter cable, C-style, 1 heated air manifold cordset, 0.3 m	AR	
5	289761	Adapter cable, C-style, 1 adhesive manifold cordset, 0.3 m	AR	
6	316269	Splitter cable, C-style, 2 hose cordsets, 0.3 m	AR	

AR: As Required

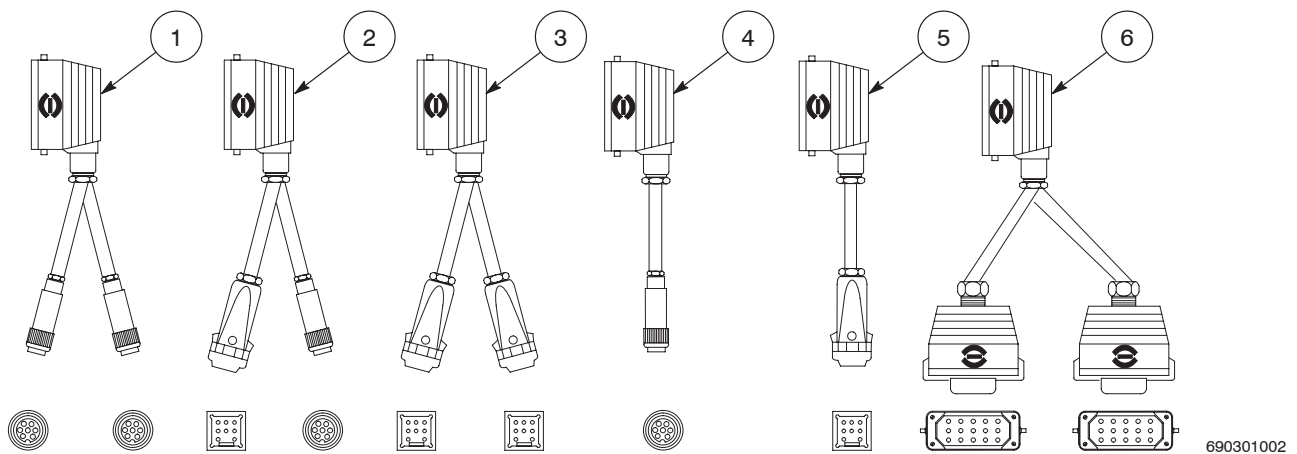
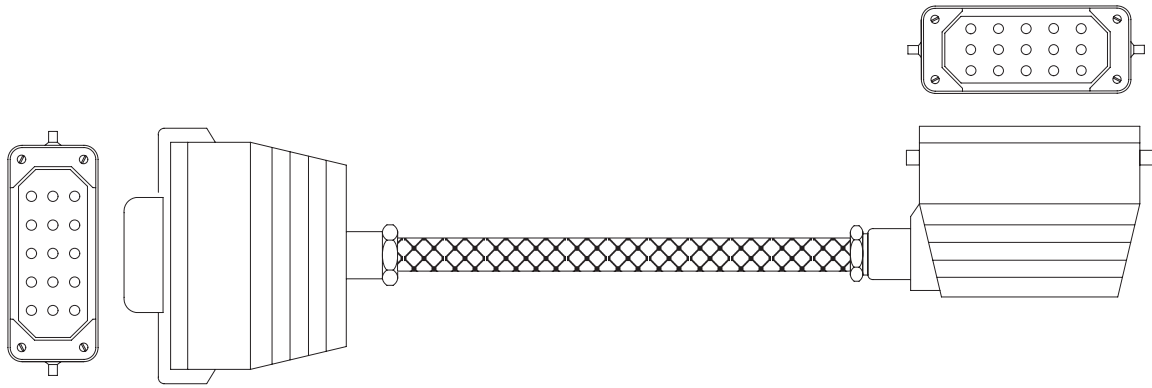

Figure 11-13 C-style splitter and adapter cables

Extension Cables

See Figures 11-14, 11-15, and 11-16. These extension cables can be used to connect splitter and adapter cables and/or hose and applicator cordsets to the electrical receptacles on the melter.

Part	Description	Note
314073	Extension cable, C-style, hose cordsets, 0.5 m (1.6 ft)	
263020	Extension cable, C-style, hose cordsets, 2 m (6.6 ft)	
157916	Extension cable, C-style, hose cordsets, 4 m (13.1 ft)	
291320	Extension cable, C-style, hose cordsets, 5 m (16.4 ft)	
258659	Extension cable, C-style, hose cordsets, 6 m (19.7 ft)	
261270	Extension cable, C-style, hose cordsets, 8 m (26.2 ft)	
261271	Extension cable, C-style, hose cordsets, 10 m (32.8 ft)	
290215	Extension cable, C-style, hose cordsets, 15 m (49.2 ft)	
315316	Extension cable, C-style, hose cordsets, 25 m (82.0 ft)	
252407	Extension cable, C-style, adhesive manifold cordsets, 0.6 m (2.0 ft)	
291658	Extension cable, C-style, adhesive manifold cordsets, 2 m (6.6 ft)	
256538	Extension cable, C-style, adhesive manifold cordsets, 3 m (9.8 ft)	
285458	Extension cable, C-style, adhesive manifold cordsets, 4 m (13.1 ft)	
254466	Extension cable, C-style, adhesive manifold cordsets, 5 m (16.4 ft)	
264599	Extension cable, C-style, adhesive manifold cordsets, 6 m (19.7 ft)	
256559	Extension cable, C-style, adhesive manifold cordsets, 7 m (23.0 ft)	
292229	Extension cable, C-style, adhesive manifold cordsets, 8 m (26.2 ft)	
279770	Extension cable, C-style, adhesive manifold cordsets, 11 m (36.1 ft)	
255178	Extension cable, C-style, heated air manifold cordsets, 1 m (3.3 ft)	
257301	Extension cable, C-style, heated air manifold cordsets, 2 m (6.6 ft)	
255373	Extension cable, C-style, heated air manifold cordsets, 3 m (9.8 ft)	
254467	Extension cable, C-style, heated air manifold cordsets, 4 m (13.1 ft)	
254468	Extension cable, C-style, heated air manifold cordsets, 5 m (16.4 ft)	
254464	Extension cable, C-style, heated air manifold cordsets, 6 m (19.7 ft)	
255524	Extension cable, C-style, heated air manifold cordsets, 7 m (23.0 ft)	
256265	Extension cable, C-style, heated air manifold cordsets, 8 m (26.2 ft)	
256533	Extension cable, C-style, heated air manifold cordsets, 9 m (29.5 ft)	
263085	Extension cable, C-style, heated air manifold cordsets, 10 m (32.8 ft)	



690301005

Figure 11-14 C-style hose cordset extension cable



690301003

Figure 11-15 C-style adhesive manifold cordset extension cable



690301004

Figure 11-16 C-style heated air manifold cordset extension cable

Recommended Spare Parts and Supplies

For a general spare parts and supplies list, refer to *Recommended Spare Parts and Supplies* in Section 8, *Parts*.

Part	Description	Note
158474	Cordset, adhesive manifold, C-style, thermocouple, 7-wire	
152126	Cordset, heated air manifold, C-style, thermocouple, 5-wire	
- - - - -	Heaters, adhesive and heated air manifolds	A
152130	Thermocouple, adhesive and heated air manifolds	
815557	Thermostat, adhesive manifold	
939522	Pin, crimp connector, 20–26 gauge, silver (for adhesive manifold cordset heaters)	
939521	Pin, crimp connector, 20–16 gauge, silver (for adhesive manifold cordset thermocouples)	
276784	Plug, 7-pin, water-resistant (heated air manifold cordset connector)	
165415	Lubricant, heater (for the heaters)	
NOTE A: Refer to <i>Applicator-Specific Reference Drawings</i> in Section 8, <i>Parts</i> , for the part numbers of the heaters for your applicator.		

Technical Data

Electrical Specifications

Refer to the identification plate on the applicator for voltage and wattage information. For the location of the identification plate on your applicator, refer to the reference drawing of the applicator in *Applicator-Specific Reference Drawings* in Section 8, *Parts*.

Wiring Diagrams

These wiring diagrams are provided for your reference as needed during troubleshooting activities. Refer also to *Applicator-Specific Reference Drawings* in Section 8, *Parts*, for wiring diagrams specific to your applicator.

NOTE: The term “sensor” as used in these diagrams refers to the thermocouple.

Cordsets

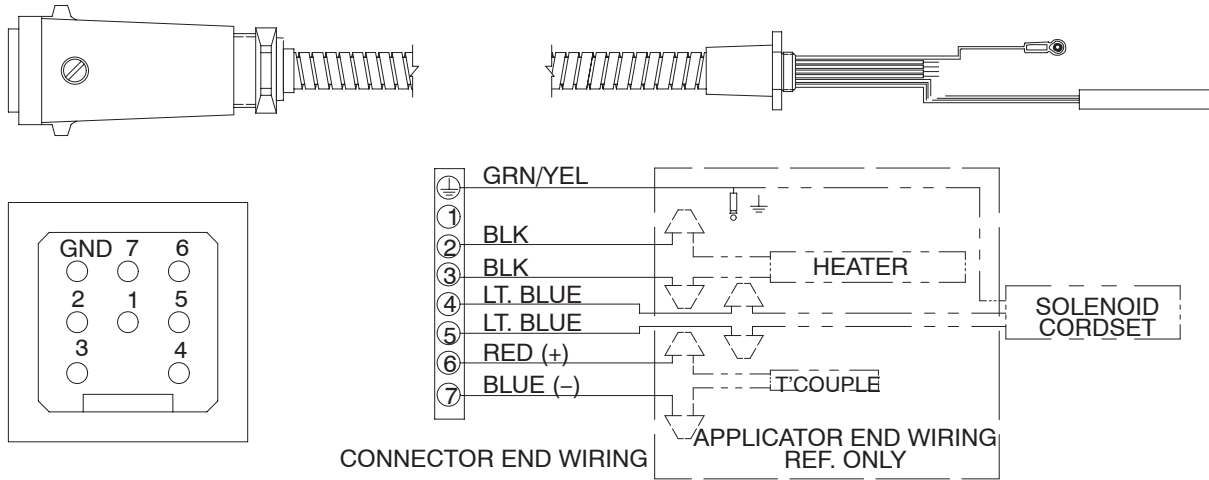

Figure 11-17 C-style adhesive manifold cordset pin positions

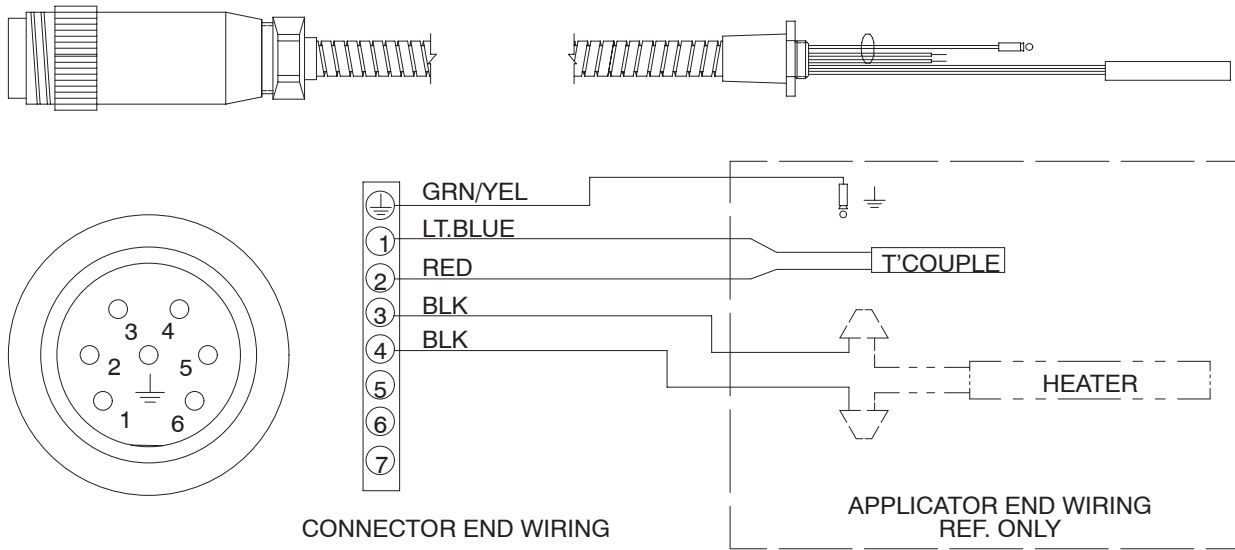

Figure 11-18 C-style heated air manifold cordset pin positions

Splitter and Adapter Cable Wiring Diagrams

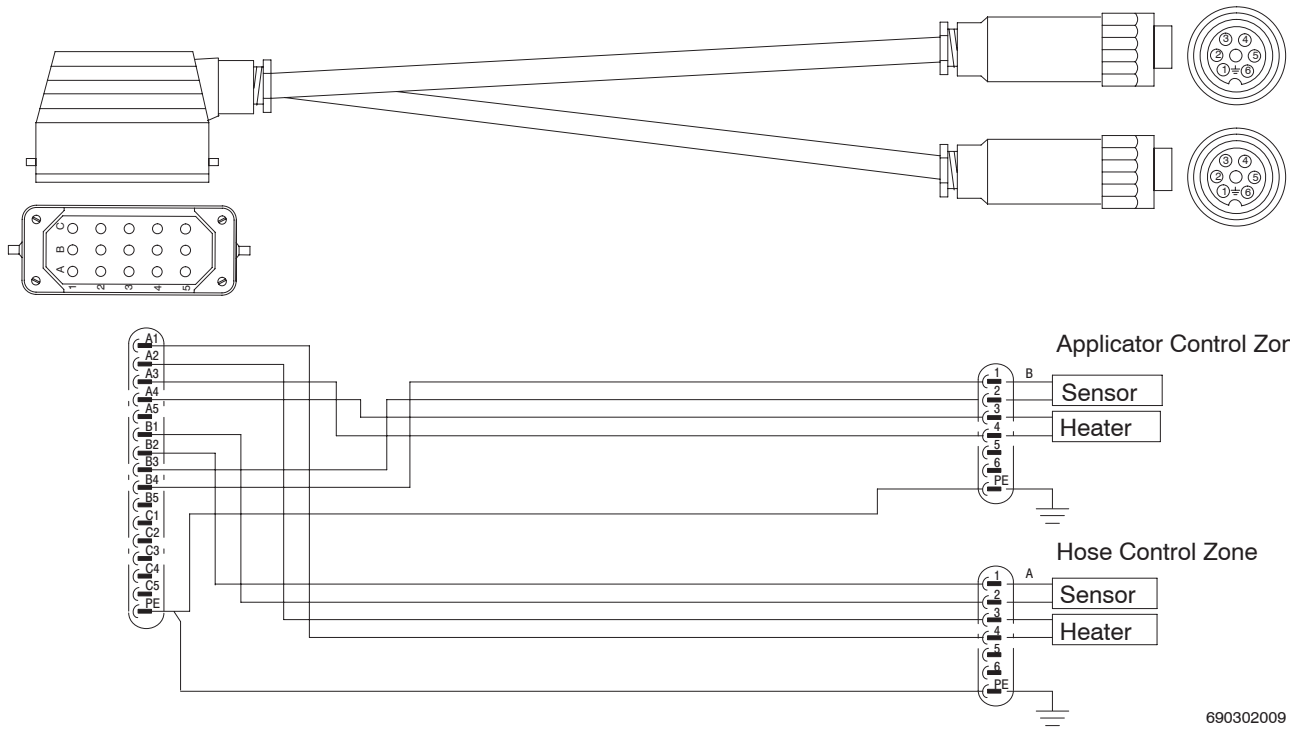

Figure 11-19 C-style splitter cable (two heated air manifold cordsets) wiring diagram

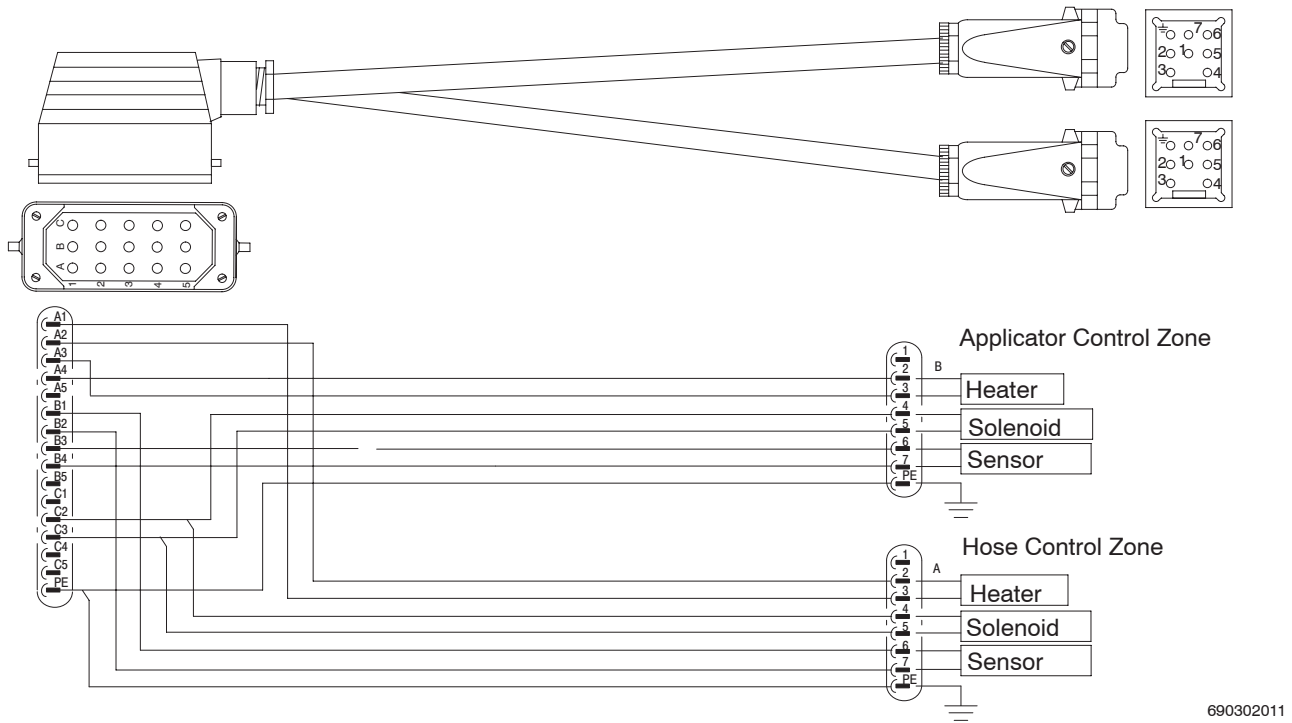
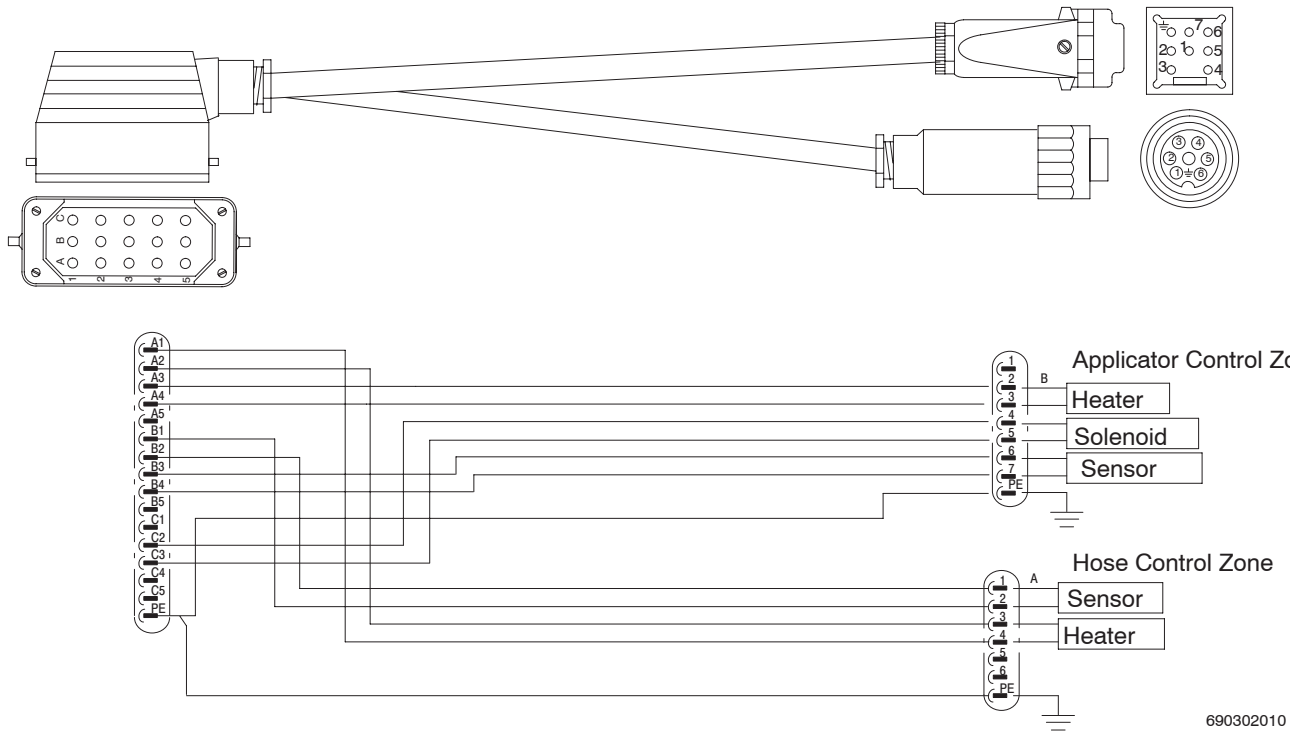
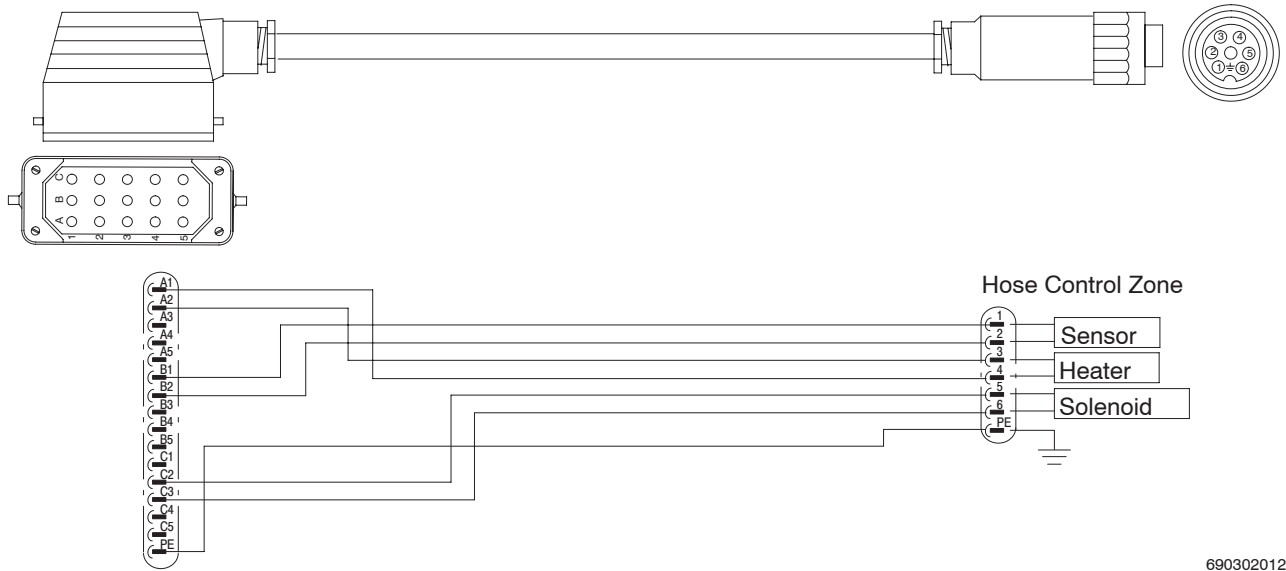

Figure 11-20 C-style splitter cable (two adhesive manifold cordsets) wiring diagram



690302010

Figure 11-21 C-style splitter cable (one adhesive manifold cordset and one heated air manifold cordset) wiring diagram



690302012

Figure 11-22 C-style adapter cable (one heated air manifold cordset) wiring diagram

Splitter and Adapter Cable Wiring Diagrams (contd)

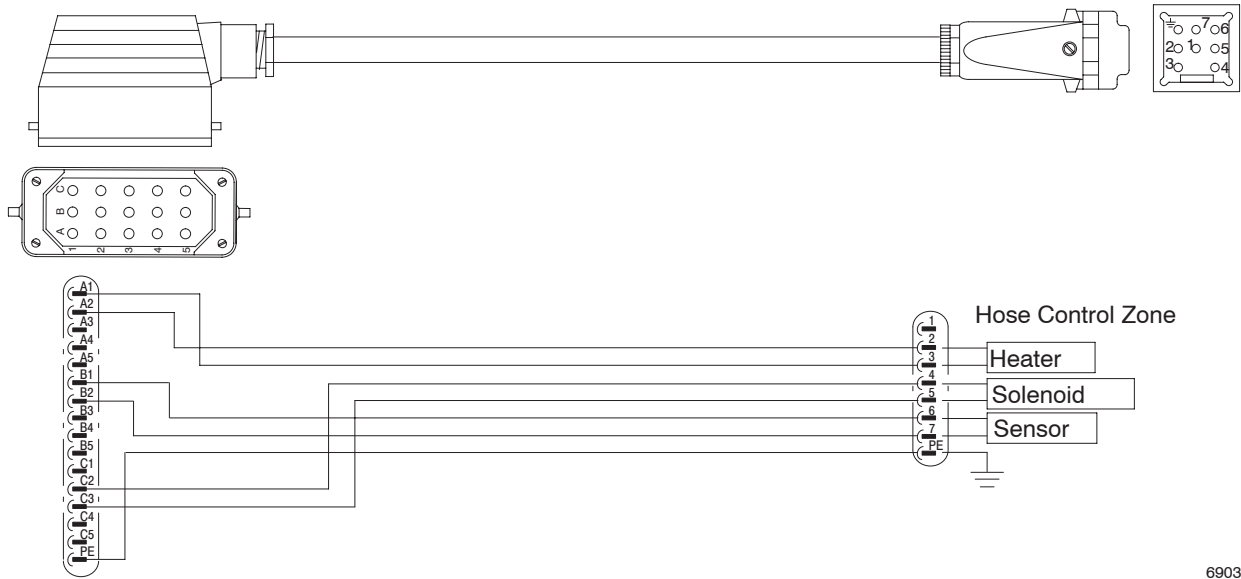

690302013

Figure 11-23 C-style adapter cable (one adhesive manifold cordset) wiring diagram

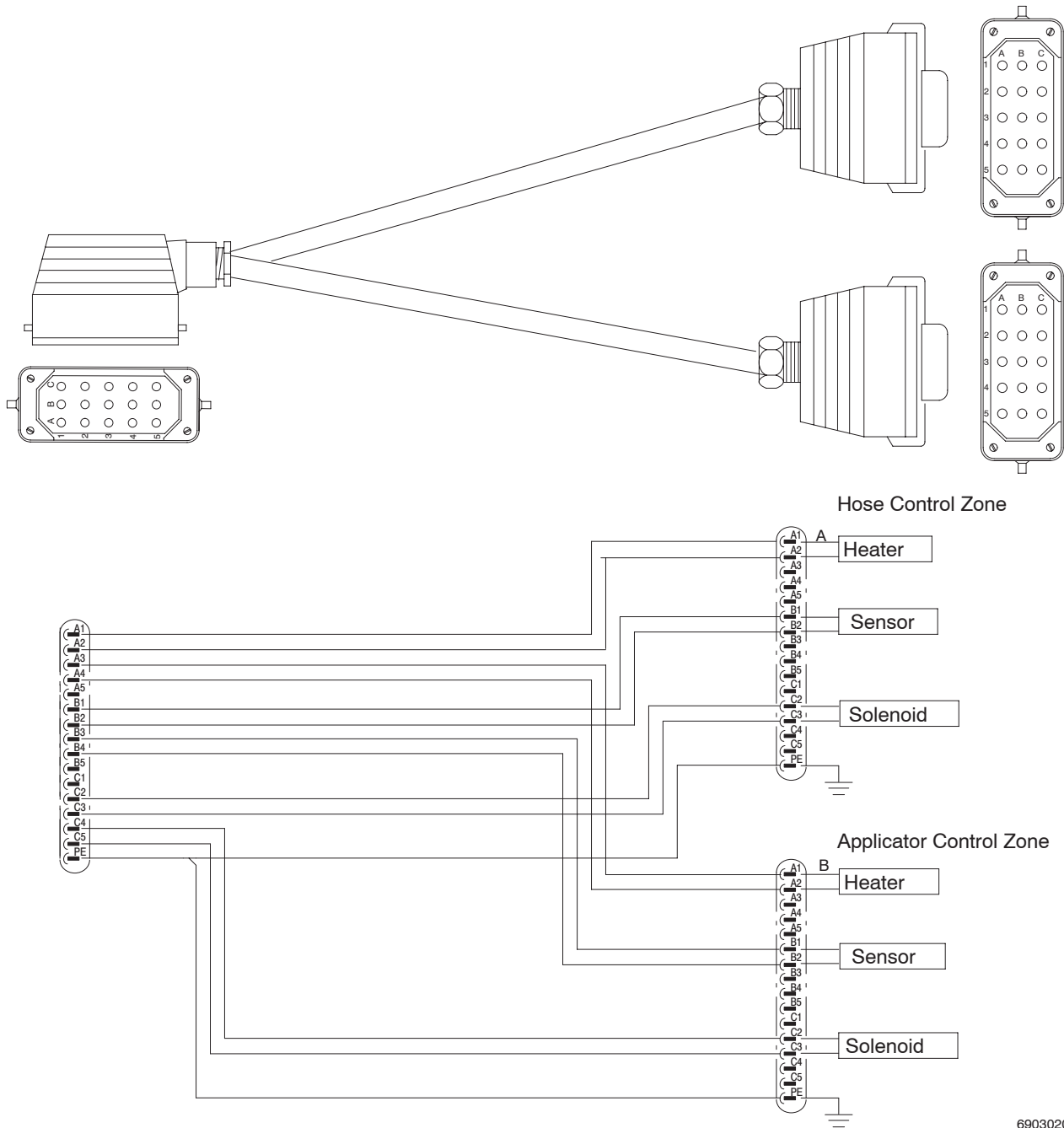

Figure 11-24 C-style splitter cable (two hose cordsets) wiring diagram

690302014

Extension Cables

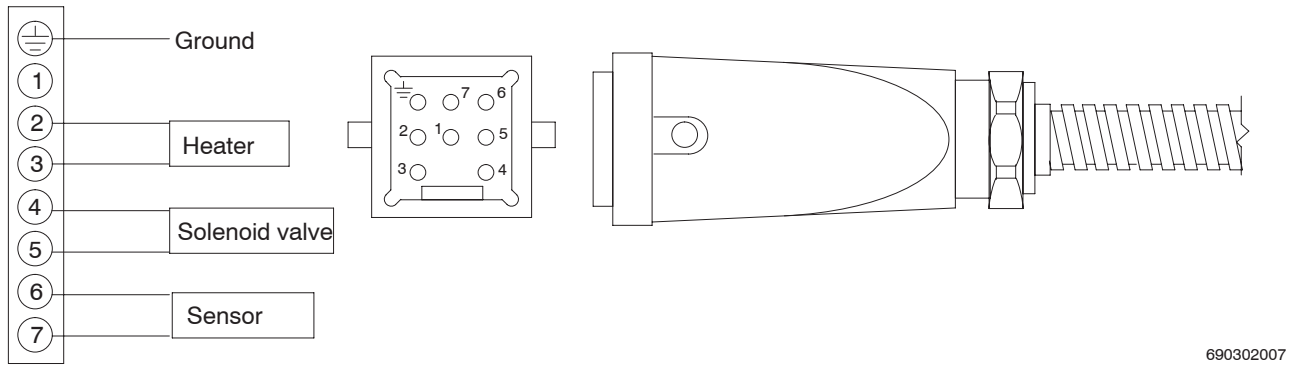

Figure 11-25 C-style adhesive manifold cordset extension cable wiring diagram

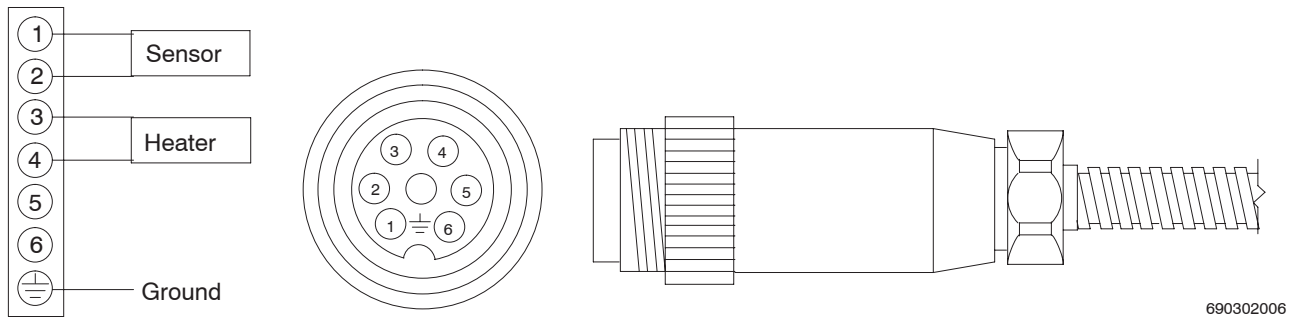
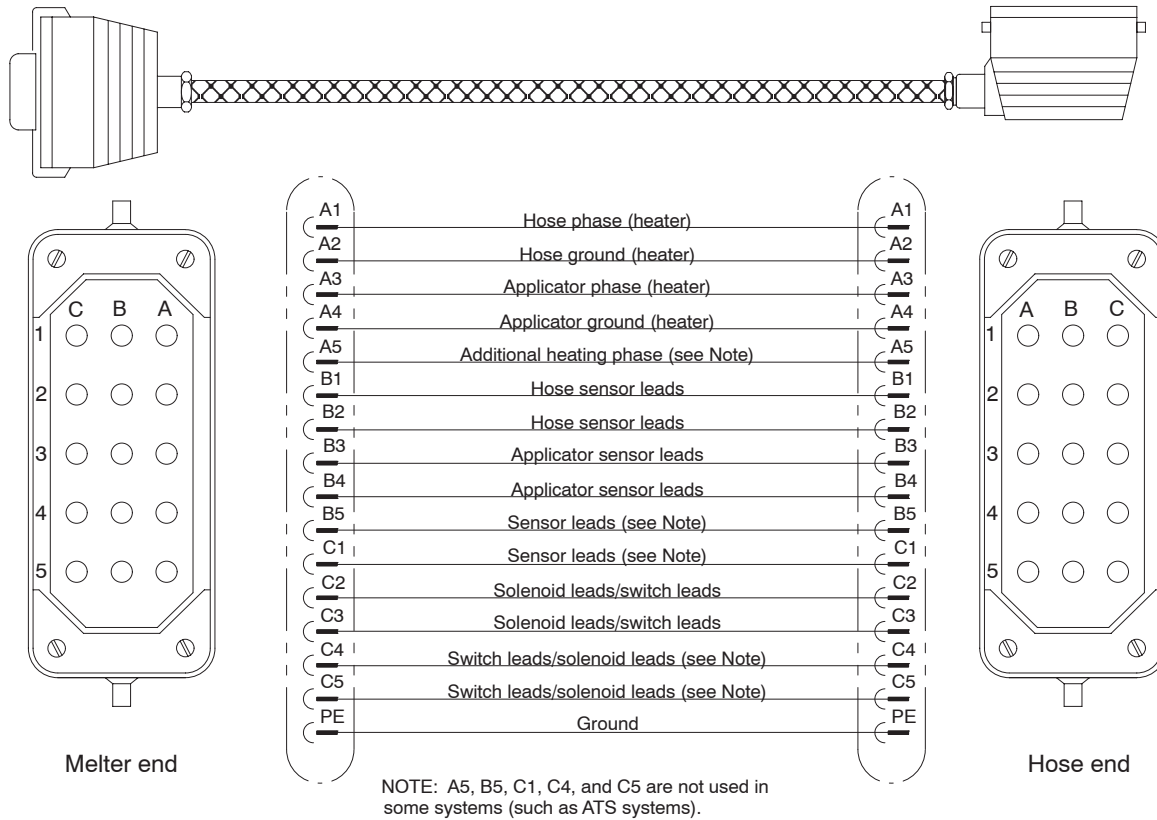

Figure 11-26 C-style heated air manifold cordset extension cable wiring diagram



690302008

Figure 11-27 C-style hose cordset extension cable wiring diagram

