

## Section 9

# Module

**NOTE:** This section applies to applicators with CF200PAD modules.

## Table of Contents

<b>Module</b> .....	<b>9-1</b>
Introduction .....	9-3
Module Overview .....	9-4
Pattern Control Troubleshooting .....	9-6
Module Service .....	9-9
Synchronizing Multi-Module Adhesive Output .....	9-9
Replacing a Module .....	9-11
Remove the Module .....	9-11
Install the Module .....	9-12
Rebuilding a Module .....	9-12
Prepare for Module Rebuild .....	9-13
Disassemble the Module .....	9-13
Assemble the Upper Module Components .....	9-16
Assemble the Lower Module Components .....	9-21
Install the Air Cap .....	9-22
Restore the System to Normal Operation .....	9-23
Nozzle Service .....	9-24
Removing a Nozzle .....	9-24
Installing a Nozzle .....	9-25
Cleaning Nozzles .....	9-26
Parts .....	9-31
Standard CF200PAD Module Parts .....	9-32
Right-Angle CF200PAD Module Parts .....	9-34
Nozzle Part Numbers .....	9-36
Module Service Kits .....	9-40
Recommended Spare Parts and Supplies .....	9-42
Technical Data .....	9-43
Applicator Specifications .....	9-43
Torque Specifications .....	9-44
Module Dimensions .....	9-44

This page intentionally left blank.

**WARNING:** Allow only personnel with appropriate training and experience to operate or service the equipment. The use of untrained or inexperienced personnel to operate or service the equipment can result in injury, including death, to themselves and others, and damage to the equipment.

## Introduction

This section provides troubleshooting, repair, parts, and specification information for applicators with Controlled Fiberization pattern air diffuser (CF200PAD) modules. The CF200PAD module is designed to dispense adhesive in a spiral pattern. The pattern air diffuser, which is located in the module seat, diffuses the pattern air that is supplied to the module through the heated air manifold. The diffused air then flows through the air passages in the CF nozzle, causing the adhesive to form an even spiral pattern.

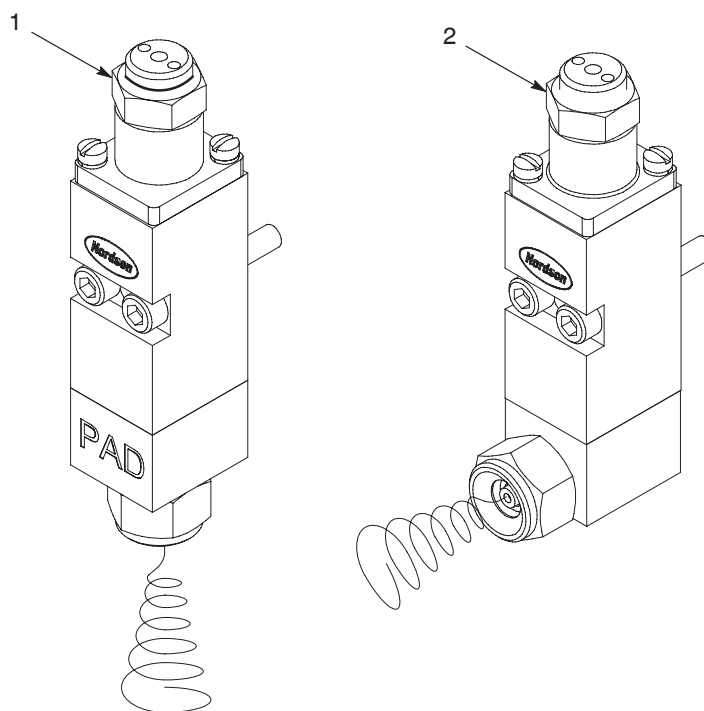

Figure 9-1 CF200PAD module

1. Standard module, adjustable

2. Right-angle module, adjustable

## Module Overview

Dispensing modules apply adhesive to a product. All modules are air-actuated (or air-open), meaning that an air supply controlled by a solenoid valve is required to open the module. Modules are then spring-closed. In air-open, spring-close (AOSC) modules, the actuating air lifts a needle-and-piston assembly inside the module, thus opening the module and allowing adhesive to flow through the nozzle onto the product. When the actuating air shuts off, a spring returns the needle-and-piston assembly to the closed position, closing the module.

A separate air supply is used to supply pattern air to the module; this air enters the pattern air inlet and is directed onto the adhesive exiting the nozzle, creating the desired spray pattern.

Figure 9-2 shows the flow of adhesive and air through a standard and right-angle module. Figure 9-3 shows the key parts of a module.

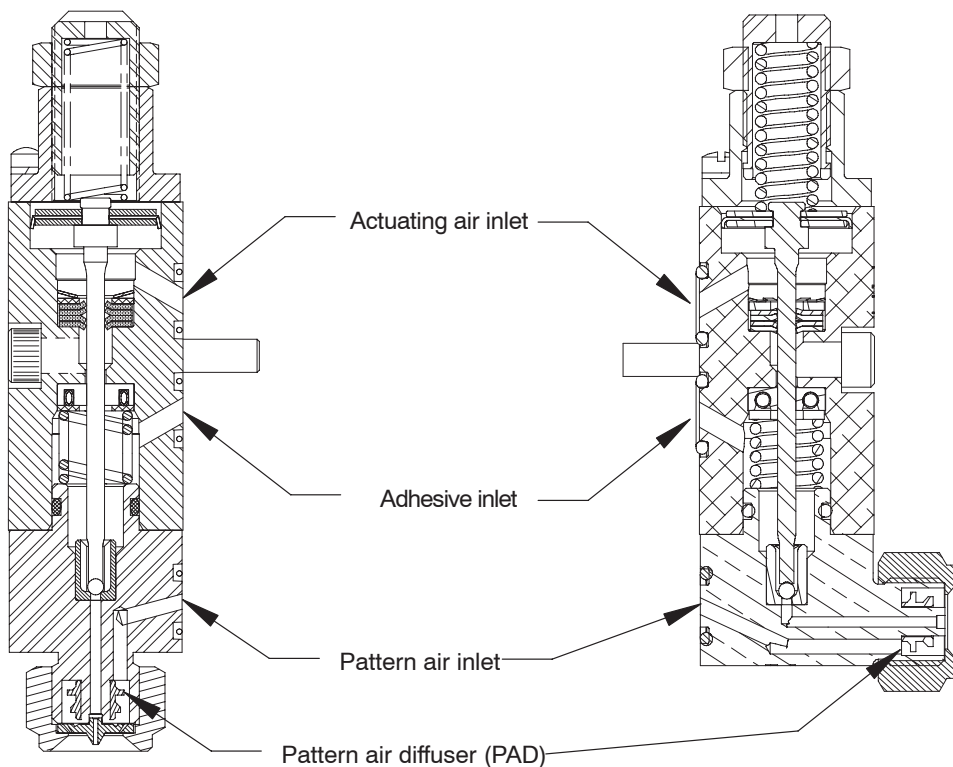

Figure 9-2 Flow of adhesive and air through a CF200PAD standard module (left) and right-angle module (right)

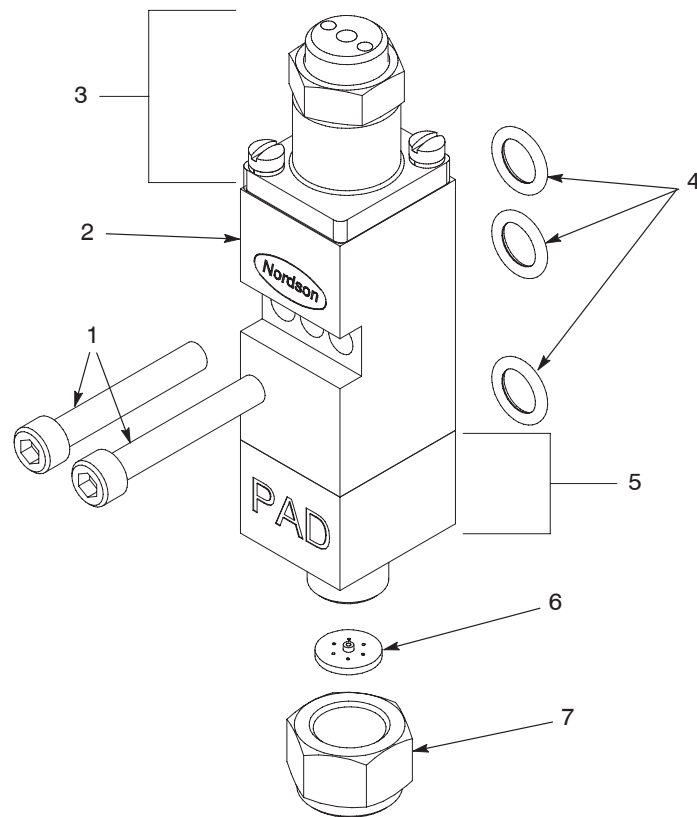

Figure 9-3 Key parts of a CF200PAD module (standard module shown)

- |                                  |                         |
|----------------------------------|-------------------------|
| 1. Module mounting screws        | 5. Module seat assembly |
| 2. Module body                   | 6. CF nozzle disk       |
| 3. Air cap assembly (adjustable) | 7. Nozzle-retaining nut |
| 4. Module O-rings                |                         |

# Pattern Control Troubleshooting

Use this troubleshooting table if you are experiencing adhesive pattern control problems. For all other troubleshooting, refer to Section 6, *Troubleshooting*.

**NOTE:** To aid in detecting pattern control problems, direct a strobe light on the adhesive as it flows onto the product.

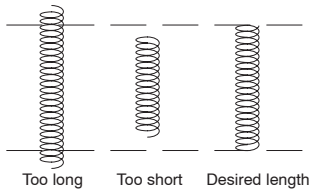
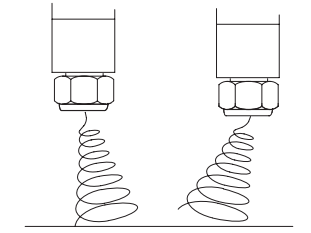
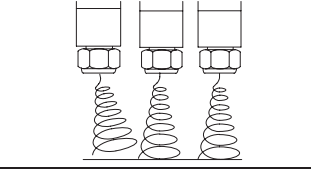
Problem	Possible Cause	Corrective Action	Example
<b>Adhesive flow not cutting off properly, causing a poor adhesive pattern</b>	Worn or charred module and/or seat  System pressure too high	Replace or rebuild the module. To replace a module, refer to <i>Replacing a Module</i> . To rebuild a module, order a module rebuild kit and follow the instructions in the kit. Refer to <i>Module Service Kits</i> .  Decrease the system pressure. Refer to the melter manual.	
<b>Beginnings and ends of adhesive patterns on multi-module applicator not aligned</b>	Modules not synchronized (loading screws not properly adjusted)	Adjust the module loading screws. Refer to <i>Synchronizing Multi-Module Applicator Adhesive Output</i> .	 <p>Too long      Too short      Desired length</p>
<b>Pattern off-center (skewed)</b>	Blocked air passage(s)  Blocked adhesive passage(s)	Remove the nozzle and use a pin-type probe to clean the blocked air passage(s). Refer to <i>Cleaning Nozzles</i> .  Remove the nozzle and use a pin-type probe to clean the blocked adhesive passage(s). Refer to <i>Cleaning Nozzles</i> .	
<b>End pattern oriented toward center of applicator</b>	Air currents in area near module	Eliminate the air current or add a blank module that provides only pattern air next to the end module.	

*Continued on next page*

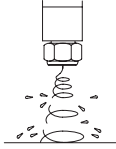
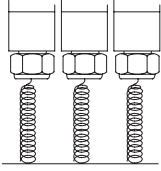
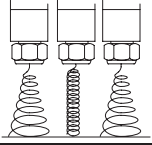
Problem	Possible Cause	Corrective Action	Example
<p><b>Pattern breaking up (adhesive droplets thrown from stream or overspray)</b></p>	<p>Adhesive and/or pattern air temperature too hot or pattern air pressure too high</p> <p>Adhesive output rate too low</p> <p>Damaged nozzle (adhesive leaking into air passages and being blown into the pattern)</p> <p>Nozzle too far from product</p> <p>Adhesive patterns overlapping and interfering with one another</p>	<p>Adjust the adhesive or air temperature and air pressure settings to the last good run settings; then check the adhesive output.</p> <p>Increase the system pressure or troubleshoot the output rate problem at the melter. Refer to the melter manual. Check for blockages in the nozzle, applicator, or hose. Refer to <i>Checking for Blockages</i> in Section 6, <i>Troubleshooting</i>.</p> <p>Replace the nozzle.</p> <p>Shorten the distance between the nozzle and the product.</p> <p>Replace the nozzles on the modules that are producing adhesive streams that interfere with the other module adhesive streams.</p>	
<p><b>All patterns too narrow</b></p>	<p>Adhesive and/or pattern air temperature too cool, pattern air pressure too low, or applicator mounted too close to substrate</p> <p>Adhesive flow rate too high</p>	<p>Adjust the adhesive temperature and air pressure settings to the last good run settings and/or check the applicator mounting height; then check the adhesive output.</p> <p>Decrease the system pressure or troubleshoot the output rate problem at the melter. Refer to the melter manual.</p>	
<p><b>One pattern too narrow</b></p>	<p>Incorrect or damaged nozzle; possible restriction in heated air manifold or pattern air input on module</p>	<p>Verify that the nozzle part number is correct. Check the nozzle for damage and replace if needed. Remove the module and check for blockage in the pattern air path.</p>	

*Continued on next page*

# Pattern Control Troubleshooting *(contd)*

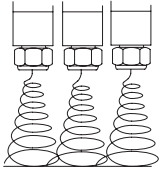
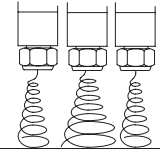
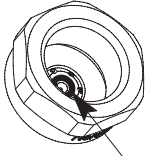
Problem	Possible Cause	Corrective Action	Example
<p><b>All patterns too wide</b></p>	<p>Adhesive and/or pattern air temperature too warm, pattern air pressure too high, or applicator mounted too far from substrate</p> <p>Adhesive flow rate too low</p> <p>Nozzle adhesive opening too large</p>	<p>Adjust the applicator temperature and air pressure settings to the last good run settings and/or check the applicator mounting height; then check the adhesive output.</p> <p>Increase the system pressure or troubleshoot the output rate problem at the melter. Refer to the melter manual.</p> <p>Change to a nozzle with a smaller adhesive opening. Refer to <i>Nozzle Part Numbers</i>.</p>	
<p><b>One pattern too wide</b></p>	<p>Incorrect or damaged nozzle; partially blocked adhesive or air passage(s) in nozzle</p>	<p>Verify that the nozzle part number is correct. Refer to <i>Nozzle Part Numbers</i>. Use a pin-type probe to clean the nozzle or check the nozzle for damage and replace if needed.</p>	
<p><b>Irregular pattern or adhesive leakage on one module</b></p>	<p>Nozzle overtightened and distorted or O-ring missing on unibody nozzle</p>	<p>Replace the nozzle or install a new nozzle O-ring. Tighten disk nozzles to 3.4 N•m (30 in.-lb) and unibody nozzles to 0.6 N•m (5 in.-lb).</p>	 <p>Unibody nozzle O-ring</p>

## Module Service

This part of Section 9 provides module-related service procedures.

### Synchronizing Multi-Module Adhesive Output

A loading screw located in the top of the modules can be used to fine-tune the alignment of the adhesive patterns of multi-module applicators, as shown in Figure 9-4.

You will need the following items:

- $\frac{5}{8}$ -in. wrench
- cap/nozzle/filter multi-tool (part 1059671)

**NOTE:** Refer to *Parts* for the part numbers of parts, tools, and supplies.

**CAUTION:** Do not use the loading screw to increase or decrease the amount of adhesive output (flow rate). To change the flow rate, adjust the melter pump speed.

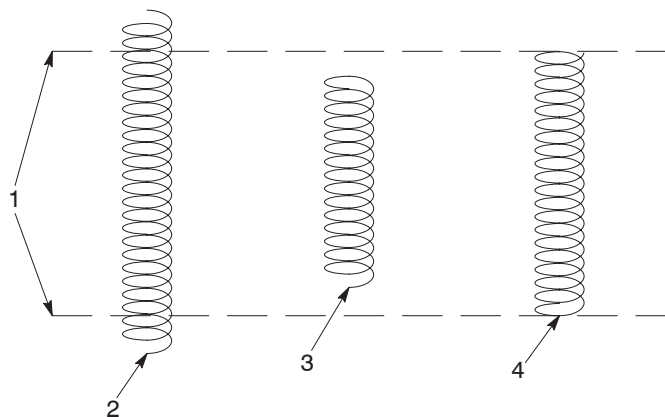

420405008

Figure 9-4 Results of module loading screw adjustments

- |                     |                           |
|---------------------|---------------------------|
| 1. Target area      | 3. Pattern too short      |
| 2. Pattern too long | 4. Desired pattern length |

## Synchronizing Multi-Module Adhesive Output *(contd)*

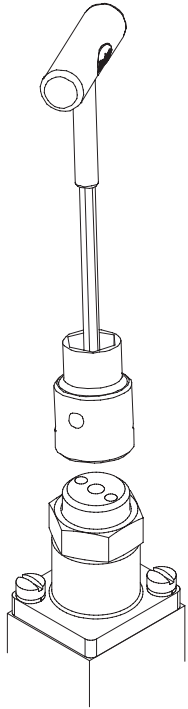

Using the multi-tool, part 1059671, to adjust a module

See Figure 9-5. To adjust a loading screw, loosen the locking nut (2) at the top of the module and hold it loosely in place with a  $\frac{5}{8}$ -in. wrench while turning the loading screw (1) with the multi-tool; then tighten the locking nut. Turn the loading screw as follows:

- To decrease the length of a pattern, turn the loading screw clockwise. This shortens the length at both ends of the pattern.
- To increase the length of a pattern, turn the loading screw counterclockwise. This increases the length at both ends of the pattern.

**NOTE:** If the module loading screw is tightened too much, the module will not dispense any adhesive.

To return a loading screw to the factory setting, loosen the locking nut, turn the screw clockwise until it bottoms out, back the screw out three full turns (counterclockwise), and tighten the locking nut.

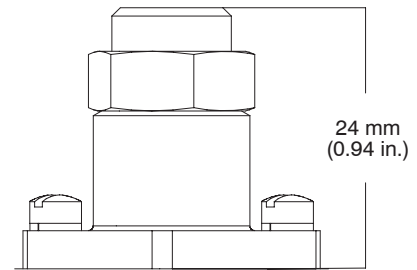
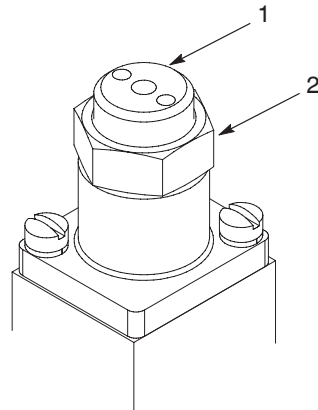

Figure 9-5 Location of the module loading screw and locking nut

1. Loading screw

2. Locking nut

## Replacing a Module

You will need the following items:

- appropriate tools, including a torque wrench
- drain pans and disposable rags
- replacement module
- replacement O-rings (if needed)
- O-ring lubricant (if needed)
- anti-seize lubricant

**NOTE:** Refer to *Parts* for the part numbers of parts, tools, and supplies.

**NOTE:** Modules can be rebuilt. To rebuild a module, order the appropriate module rebuild kit and follow the instructions in the kit. For kit part numbers, refer to *Module Service Kits* under *Parts* later in this section.

### Remove the Module

1. Heat the system to application temperature.
2. Relieve system pressure. Refer to *Relieving System Pressure* in Section 10, *Filter*.
3. Trigger the applicator solenoid valves to relieve any remaining pressure.
4. Shut off the module-actuating air.
5. Decrease the pattern air pressure. Leave just enough air pressure to prevent adhesive from entering the pattern air outlet.
6. See Figure 9-6. Remove the module mounting screws (1) and then remove the module. Remove the module O-rings (2) for inspection.

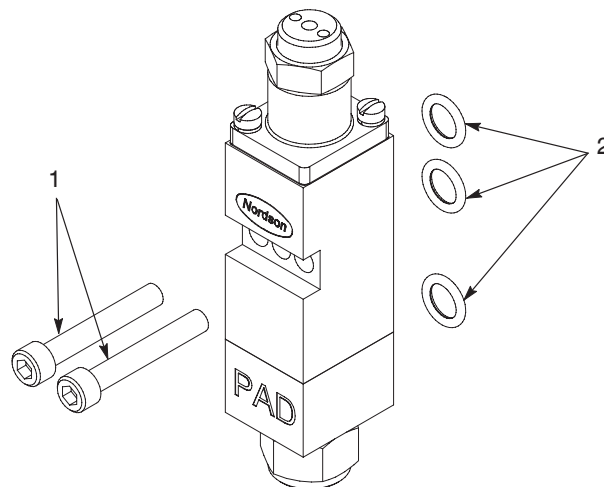

Figure 9-6 Replacing a module (standard module shown)

1. Mounting screws

2. O-rings

### ***Install the Module***

1. Wipe off any adhesive on the applicator, especially around the air passages.
2. Ensure that the module O-rings are lubricated and properly inserted in the O-ring bores on the back of the replacement module.
3. Coat the module mounting screws with anti-seize lubricant and use them to secure the new module to the applicator. Tighten the screws to 3.4 N•m (30 in.-lb).
4. Restore the system to normal operation. For best results, tighten the module mounting screws again after the applicator reaches application temperature.

## **Rebuilding a Module**

Two types of module rebuild kit are available: one type includes the needle-and-piston assembly and the other does not. In addition, several other module service kits are offered. Refer to *Module Service Kits* under *Parts*.

**NOTE:** Because the module rebuild kits include generic instructions, this procedure is provided for module-specific reference as needed.

You will need the following items:

- hex wrenches and screwdrivers
- $\frac{5}{8}$ -in wrench
- cap/nozzle/filter multi-tool (part 1059671)
- module rebuild tools
  - retaining ring removal tool, part 272821, or small probe set
  - base tool, part 272824
  - seal tool, part 272823
  - piston insertion tool, part 274973
- hot water or a heat gun
- small ruler or measuring tape
- applicable module service kits
- replacement O-rings for the back of the module
- Teflon paste
- neat's foot oil
- O-ring lubricant

**NOTE:** Refer to *Parts* for the part numbers of parts, tools, and supplies.

### ***Prepare for Module Rebuild***

1. To ease module disassembly, ensure that the adhesive in the system is heated at least to the softening point.
2. Remove the nozzle from the module to be rebuilt. Refer to *Removing a Nozzle* later in this section.
3. Remove the module from the applicator. Refer to *Remove the Module* earlier in this section.

### ***Disassemble the Module***

1. See Figure 9-7. Remove and discard the O-rings from the back of the module.

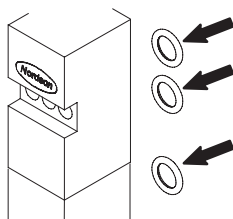

420100038

Figure 9-7 Removing the O-rings located on the back of the module

2. See Figure 9-8. Remove the air cap assembly (2) from the top of the module. The large compression spring (3) may fall out when you remove the assembly.

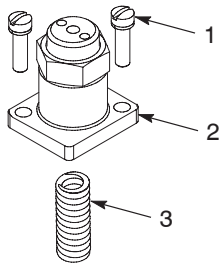
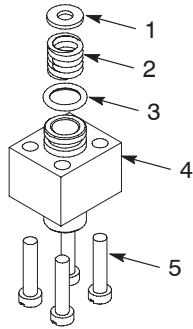

Figure 9-8 Removing the air cap assembly

- |                             |                             |
|-----------------------------|-----------------------------|
| 1. Air cap attachment screw | 3. Large compression spring |
| 2. Air cap assembly         |                             |

**Disassemble the Module** (contd)

3. See Figure 9-9. Remove the seat (4) and then remove the O-ring (3) from the seat. Discard the O-ring.
4. Remove the small compression spring (2) and lower seal support disk (1) from the bottom of the module body. You may need to use the retaining ring removal tool (or a similar tool).



420100039

Figure 9-9 Removing the seat, O-ring, small compression spring, and lower seal support disk

- |                             |                |
|-----------------------------|----------------|
| 1. Lower seal support disk  | 4. Seat        |
| 2. Small compression spring | 5. Seat screws |
| 3. Seat O-ring              |                |

5. See Figure 9-10. Remove the needle-and-piston assembly from the top of the module body.

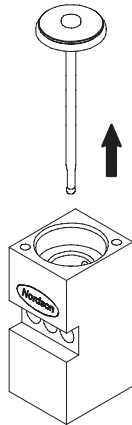

420100040

Figure 9-10 Removing the needle-and-piston assembly

6. See Figure 9-11. Use the retaining ring removal tool (or a similar tool) to remove the retaining ring from the module body.

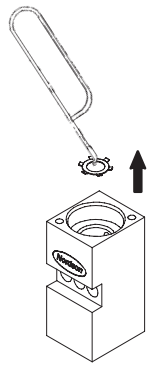

420100041

Figure 9-11 Removing the retaining ring

7. See Figure 9-12. Remove the upper seal support disk (1) and the upper (2) and lower (3) hat seals from the top of the module body.

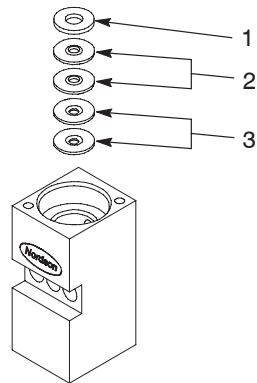

420100042

Figure 9-12 Removing the upper seal support disk and the hat seals

- |                            |                    |
|----------------------------|--------------------|
| 1. Upper seal support disk | 3. Lower hat seals |
| 2. Upper hat seals         |                    |

### Disassemble the Module *(contd)*

**CAUTION:** Risk of equipment damage. Do not scrape the inside of the module body when using a tool to remove the spring seal.

- See Figure 9-13. Remove the spring seal by turning the module body over and using the retaining ring removal tool (or a similar tool).

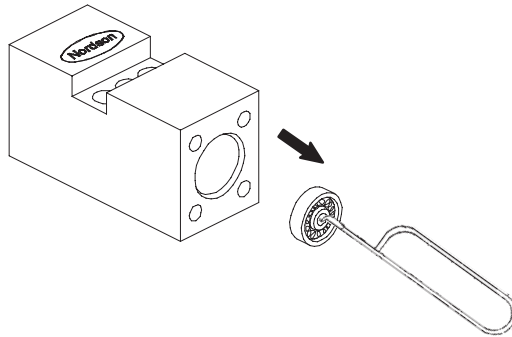

420100043

Figure 9-13 Removing the spring seal

The module is now fully disassembled. Be sure to discard any components that will be replaced and have all new components ready for module assembly.

### Assemble the Upper Module Components

**WARNING:** Do not change the module configuration during reassembly. Substitution of O-rings or seals from other manufacturers, or the combination of a new seal with a badly worn needle, can cause adhesive to leak into the pneumatic section or out from the front of the module.

- See Figure 9-14. Place the module body (1), with the pneumatic section pointing upward, on the base tool (2) supplied with the rebuild kit.

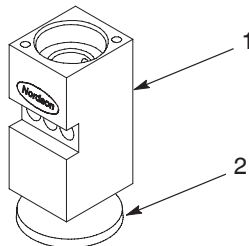

Figure 9-14 Module body on the base tool

1. Module body

2. Base tool

2. See Figure 9-16. Lubricate the seal portion of a new needle-and-piston assembly with neat's foot oil.
3. Use a heat gun or hot plate to warm the hat seals to approximately 93 °C (200 °F) to soften them. Use tweezers to handle the hat seals after softening them.
4. See Figure 9-15. Assemble the following onto the needle-and-piston assembly:
  - seal tool (1)
  - retaining ring with tangs down (2)
  - upper seal support disk (3)
  - two hat seals pointing toward the piston tool (4)
  - two hat seals pointing toward the needle ball (5)

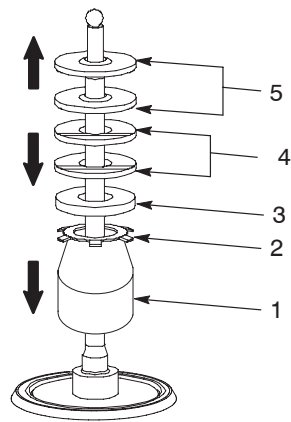

Figure 9-15 Assembling the seal tool, retaining ring, seal support disk, and hat seals on the needle-and-piston assembly

**Assemble the Upper Module Components** *(contd)*

5. See Figure 9-16. Position the piston insertion tool (3) on top of the module body.
6. Slide the needle-and-piston assembly components through the piston insertion tool into the module body. By pressing down on the center of the piston, use the seal tool (1) to compress the retaining ring, seal support disk, and hat seals (2) until the tangs on the retaining ring snap into place.

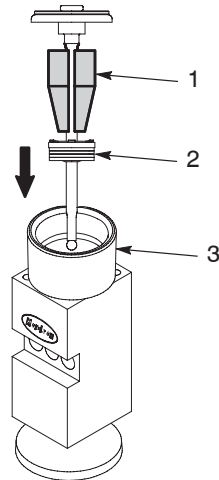

Figure 9-16 Using the seal tool to install the retaining ring, seal support disk, and hat seals

- |   |                          |
|---|--------------------------|
| 1. Seal tool  | 3. Piston insertion tool |
| 2. Retaining ring, seal support disk, and hat seals |                          |

**CAUTION:** Risk of equipment damage. When pulling the needle-and-piston assembly out of the module body, be careful not to damage or deform the piston seal.

7. Remove the piston insertion tool and lift the module off the base tool—the needle will be protruding from the bottom of the module. Hold the module body and push the needle against the table top or work surface. The needle assembly will come out enough so that it can be grasped with two fingers and pulled from the module body.

8. See Figure 9-17. Remove the seal tool from the needle.

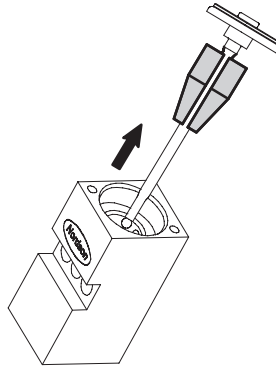

Figure 9-17 Removing the seal tool

9. See Figure 9-18. Place the module body back on the base tool (3), position the piston insertion tool (2) on top of the module, and stabilize the module on a flat surface (such as a block or table).
10. Push the needle-and-piston assembly (1) through the piston insertion tool into the module body.

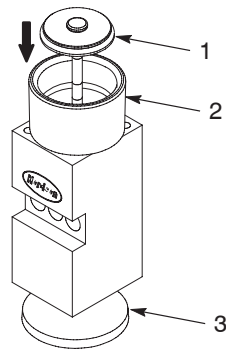

Figure 9-18 Pushing the needle-and-piston assembly through the piston insertion tool into the module body

1. Needle-and-piston assembly
2. Piston insertion tool
3. Base tool

**Assemble the Upper Module Components** (contd)

11. See Figure 9-19. Use another base tool (or a similar tool, such as a socket or nut driver) to push the needle-and-piston assembly through the seals and into the bore of the module body until the needle seats.

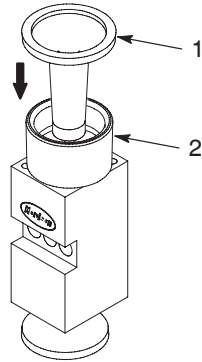

Figure 9-19 Using a base tool to push the needle-and-piston assembly into the module body

1. Base tool (or similar tool, such as a socket or nut driver)
2. Piston insertion tool

12. Remove the piston insertion and base tools.



### Install the Air Cap

1. See Figure 9-22. Position the air cap assembly (2) and large compression spring (3) on the module body. Coat the air cap screws (1) with Teflon paste and use them to secure the air cap to the module body. Tighten the screws to 1.5–1.7 N•m (13–15 in.-lb).

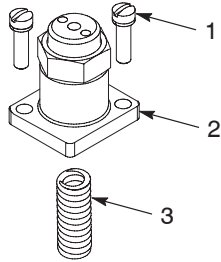
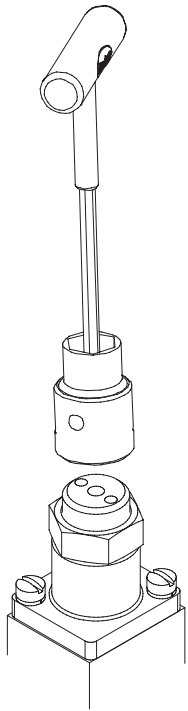

Figure 9-22 Installing the air cap assembly

- |                     |                             |
|---------------------|-----------------------------|
| 1. Air cap screw    | 3. Large compression spring |
| 2. Air cap assembly |                             |

2. See Figure 9-23. To adjust a loading screw, loosen the locking nut (2) at the top of the module and hold it loosely in place with a  $\frac{5}{8}$ -in wrench while turning the loading screw (1) with the multi-tool. Adjust the loading screw until it is 24 mm (0.94 in.) from the top of the loading screw to the base of the air cap. Tighten the locking nut to maintain the screw position.



Using the multi-tool, part 1059671, to adjust a module

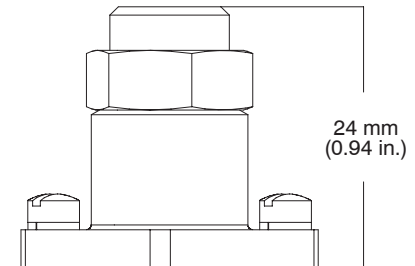
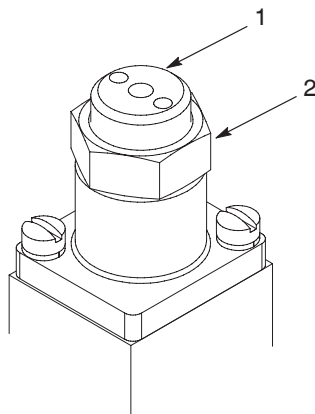
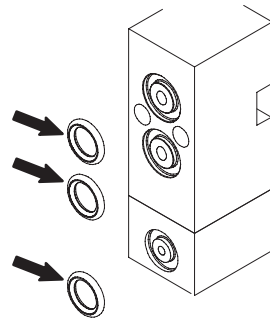

Figure 9-23 Adjusting the module loading screw

- |                  |                |
|------------------|----------------|
| 1. Loading screw | 2. Locking nut |
|------------------|----------------|

**Restore the System to Normal Operation**

1. See Figure 9-24. Coat new module O-rings with O-ring lubricant and place them in the O-ring bores on the back of the module.



420100052

Figure 9-24 Installing the module O-rings

2. Reinstall the module. Refer to *Install the Module* earlier in this section.
3. Reinstall the nozzle. Refer to *Installing a Nozzle* later in this section.
4. Restore the system to normal operation.

## Nozzle Service

This part of Section 9 provides nozzle-related service procedures.

### Removing a Nozzle

There are two types of CF nozzle: disk and unibody. On disk nozzles, the nozzle disk and nozzle-retaining nut are two separate parts. On unibody nozzles, the nozzle disk and nozzle-retaining nut are one piece. Follow these procedures to remove or install either type of nozzle. You will need the following items:

- appropriate tools, including a torque wrench
- drain pans and disposable rags
- replacement nozzle (if needed)

**NOTE:** Refer to *Parts* for the part numbers of parts, tools, and supplies.

1. Heat the system to application temperature.
2. Relieve system pressure. Refer to *Relieving System Pressure* in Section 10, *Filter*.
3. Trigger the applicator solenoid valves to relieve any remaining pressure.
4. Shut off the module-actuating air.
5. Decrease the pattern air pressure. Leave just enough air pressure to prevent adhesive from entering the pattern air outlet on the module.
6. See Figure 9-25. Use a wrench to loosen the nozzle-retaining nut.

**NOTE:** Do not use a torque wrench to loosen or remove a nozzle. Doing so will cause the torque wrench to become uncalibrated.

7. Remove the nozzle by hand.

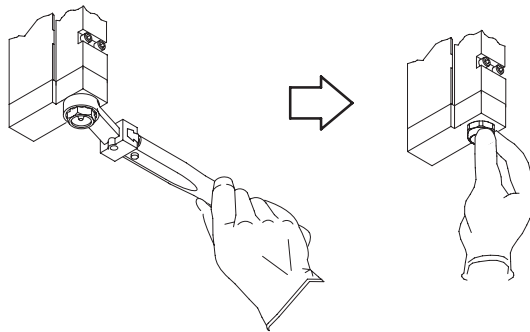
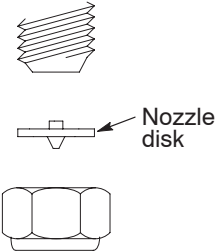
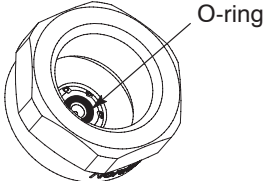

Figure 9-25 Removing a nozzle

430100006

## Installing a Nozzle

1. Clean the mating surface where the adapter or nozzle will be seated.
2. Install the nozzle as shown in the following table.

Nozzle Type	Installation Procedure
<p data-bbox="571 359 711 386">Disk nozzle</p> 	<ol style="list-style-type: none"> <li>a. Orient the nozzle disk as shown at left and place the disk inside the nozzle-retaining nut; then hand-thread the nut onto the module.</li> <li>b. Use a wrench to tighten the nut to no more than 3.4 N•m (30 in.-lb).</li> </ol>
<p data-bbox="571 669 756 697">Unibody nozzle</p> 	<ol style="list-style-type: none"> <li>a. Inspect the nozzle O-ring, replace if necessary, and ensure that the O-ring is lubricated and properly positioned.</li> <li>b. Hand-thread the nozzle onto the module. Use a wrench to tighten the nozzle to no more than 0.6 N•m (5 in.-lb).</li> </ol>

**NOTE:** Nordson offers special torque wrenches for CF disk and unibody nozzles. Refer to *Recommended Spare Parts and Supplies* under *Parts*.

## Cleaning Nozzles

Nozzles should be cleaned weekly or as needed to prevent clogging. You will need the following items:

- appropriate tools, including a torque wrench
- nozzle cleaning kits
- cleaning supplies (refer to Table 9-1)
- drain pans and disposable rags
- O-ring lubricant

**NOTE:** Refer to *Parts* for the part numbers of parts, tools, and supplies.

1. Remove the nozzles. Refer to the *Removing a Nozzle* earlier in this section.
2. Clean the nozzles using one of the Nordson-recommended methods shown in Table 9-1. Use only cleaning agents recommended by the adhesive supplier.

**WARNING:** Risk of explosion or fire. Follow the safety guidance and heating recommendations on the Material Safety Data Sheets (MSDSs) for your adhesives and nozzle-cleaning solutions.

**WARNING:** Risk of explosion or fire. Use a controlled heating device, such as a thermostatically controlled hot plate, to heat cleaning fluid, including Nordson Type-R fluid.





**CAUTION:** Risk of equipment damage. Do not use a wire brush (or a brush with bristles harder than the nozzle) to clean nozzles.

Table 9-1 Nozzle Cleaning Methods

Cleaning Method	Procedure
Citrus-based solution and ultrasonic tank  <b>NOTE:</b> This is the most thorough method.	<ol style="list-style-type: none"> <li>a. Place the nozzles in citrus-based solvent/degreasing solution and soak them overnight or for approximately 4 hours. This dissolves and loosens the adhesive and char buildup.</li> <li>b. Remove the nozzles from the citrus-based solvent/degreasing solution and place them in an alkaline solution heated to the appropriate temperature (refer to the MSDS) in an ultrasonic tank. Soak the nozzles for approximately 10 minutes. This will remove adhesive and char from the orifices.</li> <li>c. Scrub the nozzles with a soft, non-metallic brush to remove debris.</li> <li>d. Gently blow air through the nozzle orifices from the mounting side of the nozzle.</li> </ol>
Nordson Type-R fluid	<ol style="list-style-type: none"> <li>a. Place the nozzles in a controlled heating device containing Nordson Type-R fluid and heat it above the melting point of the adhesive (refer to the MSDS).</li> <li>b. Scrub the nozzles with a soft, non-metallic brush to remove debris.</li> </ol>
Electric heat gun	<ol style="list-style-type: none"> <li>a. Heat the nozzles with a flameless electric heat gun.</li> <li>b. Scrub the nozzles with a soft, non-metallic brush to remove debris.</li> </ol>
Ultrasonic tank	<ol style="list-style-type: none"> <li>a. Place the nozzles in an alkaline solution heated to the appropriate temperature (refer to the MSDS) in an ultrasonic tank. Soak the nozzles for approximately 10 minutes.</li> <li>b. Scrub the nozzles with a soft, non-metallic brush to remove debris.</li> <li>c. Gently blow air through the nozzle orifices from the mounting side of the nozzle.</li> </ol>
<i>Continued...</i>	

## Cleaning Nozzles *(contd)*

Table 9-1 Nozzle Cleaning Methods *(contd)*

Cleaning Method	Procedure
<p>Oven</p> <p><b>NOTE:</b> This method will cause discoloration of unplated brass nozzles. This discoloration is cosmetic only and will not adversely affect nozzle performance.</p> <p><b>NOTE:</b> This method is not recommended for color-coded nozzles (such as Saturn and CF steel unibody nozzles) because it will remove the color from the nozzles.</p>	<div style="display: flex; align-items: flex-start;"> <div style="margin-right: 10px;">  </div> <div> <p><b>WARNING:</b> Risk of explosion, fire, or toxic vapor release. Depending on the type of adhesive and/or organic solvent used with the nozzles, heating them in an oven can cause a hazardous event. Before using an oven to clean nozzles, consult with the oven manufacturer about the viability of this method and the safety risks. Follow the manufacturer's recommendations.</p> </div> </div> <div style="display: flex; align-items: flex-start; margin-top: 10px;"> <div style="margin-right: 10px;">  </div> <div> <p><b>WARNING:</b> Use the oven heating controls to keep the oven at the desired temperature. Do not use an oven that does not have heating controls.</p> </div> </div> <div style="display: flex; align-items: flex-start; margin-top: 10px;"> <div style="margin-right: 10px;">  </div> <div> <p><b>WARNING:</b> The heating temperature and time may need to be adjusted based on the oven type, the adhesive type, and the amount of char buildup on the nozzles. Nordson Corporation recommends testing this procedure on discarded nozzles prior to using it on good nozzles.</p> </div> </div> <p style="margin-top: 10px;"><b>CAUTION:</b> Risk of equipment damage. Remove O-rings before cleaning nozzles in an oven. Failure to do so can cause a chemical reaction that will permanently damage the nozzles.</p> <ol style="list-style-type: none"> <li>a. Ensuring that O-rings have been removed from the nozzles, place them in an electric oven heated to approximately 385 °C (725 °F). Allow the nozzles to bake for approximately 3–4 hours.</li> <li>b. Turn off the oven and allow the nozzles to cool; then remove the nozzles.</li> </ol> <div style="display: flex; align-items: flex-start; margin-top: 10px;"> <div style="margin-right: 10px;">  </div> <div> <p><b>WARNING:</b> Risk of fire. Use a heat-proof cloth to clean nozzles. Even cotton can burn in high-temperature conditions.</p> </div> </div> <div style="display: flex; align-items: flex-start; margin-top: 10px;"> <div style="margin-right: 10px;">  </div> <div> <p><b>WARNING:</b> Risk of equipment damage. Handle nozzles carefully to avoid denting the orifices, which can degrade the adhesive pattern.</p> </div> </div> <ol style="list-style-type: none"> <li>c. Wipe the nozzles with a soft cloth and then gently blow air through the nozzle orifices from the mounting side of the nozzle.</li> </ol>

3. If there is any remaining char buildup on the nozzles, gently scrape the char from the nozzles.

**CAUTION:** Risk of equipment damage. Use of an open torch, drill, or broach can damage a nozzle. Use only a pin-type probe to clean nozzle orifices and do not twist the probe inside the nozzle.

4. If cleaning of the nozzle orifices is necessary, use a pin-type probe that is one size smaller than the orifice size: insert the probe in the direction opposite the adhesive flow and then remove the probe without twisting it, as shown in Figure 9-26.

**NOTE:** Nordson offers two nozzle cleaning kits that contain a holder and several probe sizes. Refer to *Recommended Spare Parts and Supplies* under *Parts*.

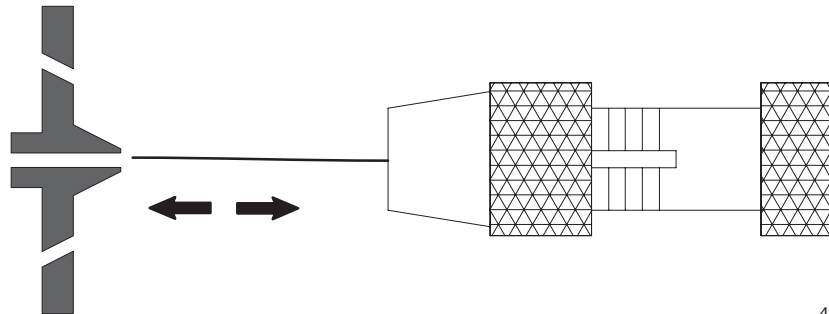

430100013

Figure 9-26 Correct direction to insert a pin-type probe into a nozzle (CF nozzle disk shown)

5. Reinstall the nozzles. Refer to *Installing a Nozzle* earlier in this section.
6. Restore the system to normal operation.

This page intentionally left blank.

# Parts

This part of Section 9 provides detailed parts lists for the module and nozzles. For other applicator parts, including a reference drawing and bill of materials specific to your applicator, refer to Section 8, *Parts*. The following chart provides guidance for reading the parts lists.

The number in the *Item* column corresponds to the circled item number in the parts list illustration. A dash in this column indicates that the item is an assembly.

The number in the *Part* column is the Nordson part number you can use to order the part. A series of dashes indicates that the part is not saleable. In this case, you must order either the assembly in which the part is used or a service kit that includes the part.

The *Description* column describes the part and sometimes includes dimensions or specifications.

The *Note* column contains letters that refer to notes at the bottom of the parts list. These notes provide important information about the part.

The *Quantity* column tells you how many of the part is used to manufacture the assembly shown in the parts list illustration. A dash or AR in this column indicates that the amount of the item required in the assembly is not quantifiable.

Item	Part	Description	Quantity	Note
—	0000000	Assembly A	—	
1	000000	• Part of assembly A	2	A
2	-----	• • Part of item 1	1	
3	0000000	• • • Part of item 2	AR	
NS	000000	• • • • Part of item 3	2	
NOTE A: Important information about item 1				
AR: As Required				
NS: Not Shown				

## Standard CF200PAD Module Parts

See Figure 9-27. Many of the module parts are available in a service kit. Refer to *Module Service Kits* later in this section.

Item	Part	Description	Quantity	Note
—	144906	Module, CF200, spray, pattern air diffuser (PAD), standard	—	A
1	1051132	• Screw, spring loading	1	
2	272289	• Nut, locking	1	
3	1051133	• Air cap, adjuster	1	
4	144892	• Spring, compression, 0.420 x 0.500 in.	1	
5	-----	• Needle with piston	1	
6	940111	• O-ring, Viton, 0.313 x 0.438 x 0.063 in.	3	
7	-----	• Body, module	1	
8	-----	• Seat, with pattern air diffuser	1	
9	119202	• Nut, nozzle-retaining	1	B
10	860258	• Screw, fillister, 8-32 x 0.875	4	
11	982871	• Screw, socket, cap, 10-32, with O-ring	2	
12	1051134	• Screw, fillister, 6-32 x 0.50 in., with lock washer	2	
13	900223	• Lubricant, O-ring, Parker, 4 oz	AR	
14	117544	• Seal, spring, $\frac{1}{8} \times \frac{7}{16} \times \frac{3}{32}$ in., PTFE	1	
15	940121	• O-ring, Viton, 0.364 ID x 0.070 W in.	1	
16	986502	• Retaining ring, internal, 43, push-on	1	
17	983012	• Disc, seal support	2	
18	-----	• Seal, hat, unformed	4	C
19	900290	• Oil, neat's foot	AR	
20	987022	• Spring, compression, 1.146 x 0.360 OD. x 0.065 in.	1	
21	-----	Disk, nozzle	1	B, D
NOTE	<p>A: Order this part for a complete replacement module. Modules can also be rebuilt. For module rebuild kit part numbers, refer to <i>Module Service Kits</i> later in this section.</p> <p>B: This part is required only if a two-piece disk nozzle is used. This part is not required if a unibody nozzle is used. Refer to <i>Nozzle Parts Numbers</i> later in this section for unibody nozzle part numbers.</p> <p>C: For a formed hat seal, order part 750553.</p> <p>D: Nozzle disks must be ordered separately. Refer to <i>Nozzle Part Numbers</i> later in this section.</p>			
AR: As Required				

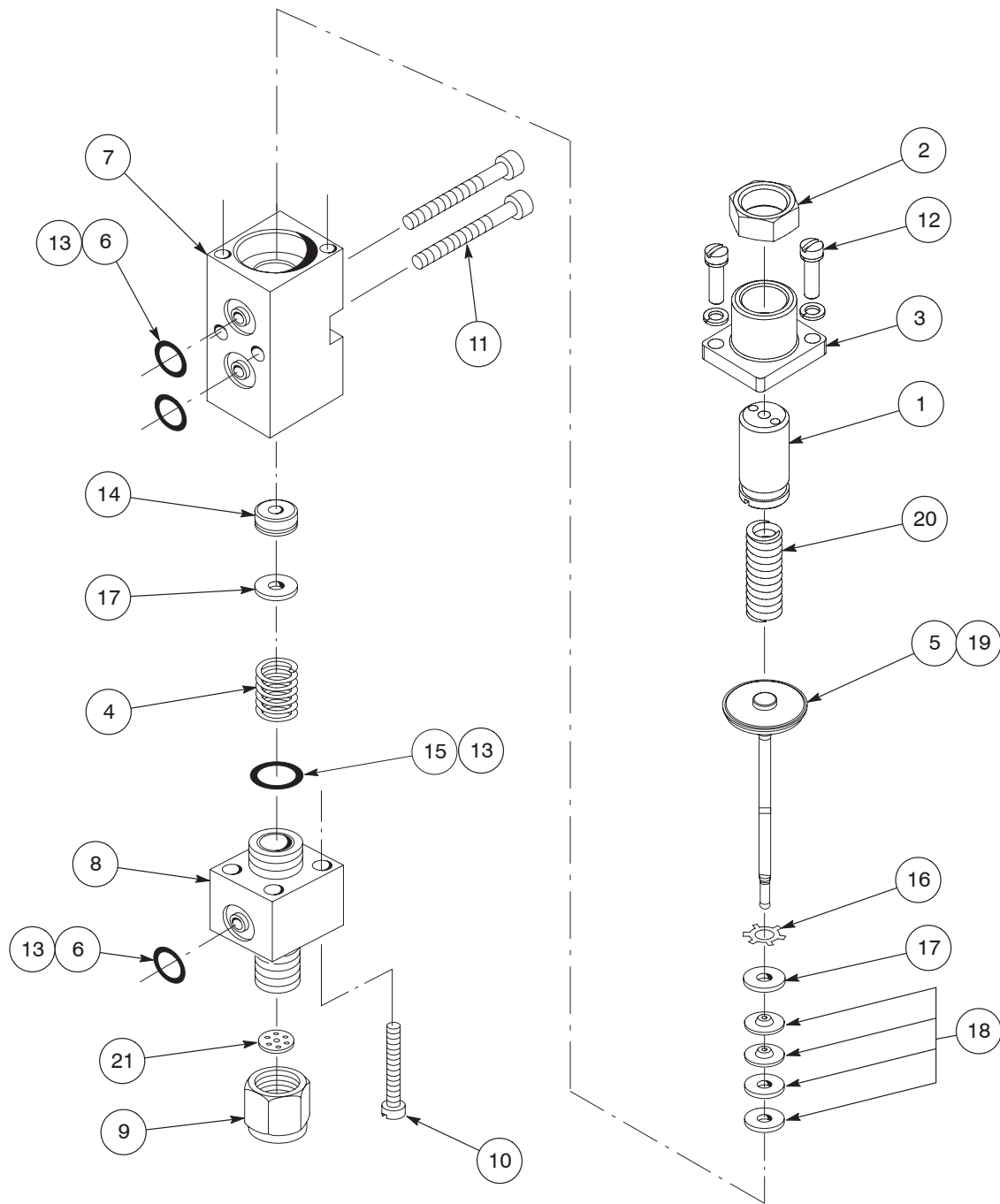

Figure 9-27 Standard CF200PAD module parts

## Right-Angle CF200PAD Module Parts

See Figure 9-28. Many of the module parts are available in a service kit. Refer to *Module Service Kits* later in this section.

Item	Part	Description	Quantity	Note
—	753166	Module, CF200, spray, pattern air diffuser (PAD), right-angle	—	A
1-3	—	• Item nos. not used	—	
4	144892	• Spring, compression, 0.420 x 0.500 in.	1	
5	—	• Item no. not used	—	
6	940111	• O-ring, Viton, 0.313 x 0.438 x 0.063 in.	3	
—	-----	• Module, H200, 90-percent	1	
7A	-----	• • Body, module	1	
7B	750553	• • Seal, hat, formed	4	
7C	983012	• • Disc, seal support	1	
7D	986502	• • Retaining, internal, 43, push-on	1	
7E	150170	• • Needle with piston	1	
7F	987022	• • Spring, compression, 1.146 x 0.360 OD x 0.065 in.	1	
7G	1051133	• • Air cap, adjuster	1	
7H	1051134	• • Screw, fillister, 6-32 x 0.050 in., with lock washer	2	
7I	272289	• • Nut, locking, 1/2-28	1	
7J	1051132	• • Screw, spring loading	1	
7K	900290	• • Oil, neat's foot	AR	
7L	117544	• • Seal, spring, 1/8 X 7/16 X 3/32 in., PTFE	1	
8	-----	• Seat, with carbide, pattern air diffuser, 90-degree	1	
9	119202	• Nut, nozzle-retaining	1	B
10	860258	• Screw, fillister, 8-32 x 0.875	4	
11	982871	• Screw, socket, cap, 10-32, with O-ring	2	
12	—	• Item no. not used	—	
13	900223	• Lubricant, O-ring, Parker, 4 oz	AR	
14	—	• Item no. not used	—	
15	940121	• O-ring, Viton, 0.364 ID x 0.070 W in.	1	
16	—	• Item no. not used	—	
17	983012	• Disc, seal support	1	
18	-----	Disk, nozzle	1	B, C

NOTE A: Order this part for a complete replacement module. Modules can also be rebuilt. For module rebuild kit part numbers, refer to *Module Service Kits* later in this section.

B: This part is required only if a two-piece disk nozzle is used. This part is not required if a unibody nozzle is used. Refer to *Nozzle Parts Numbers* later in this section for unibody nozzle part numbers.

C: Nozzle disks must be ordered separately. Refer to *Nozzle Part Numbers* later in this section.

AR: As Required

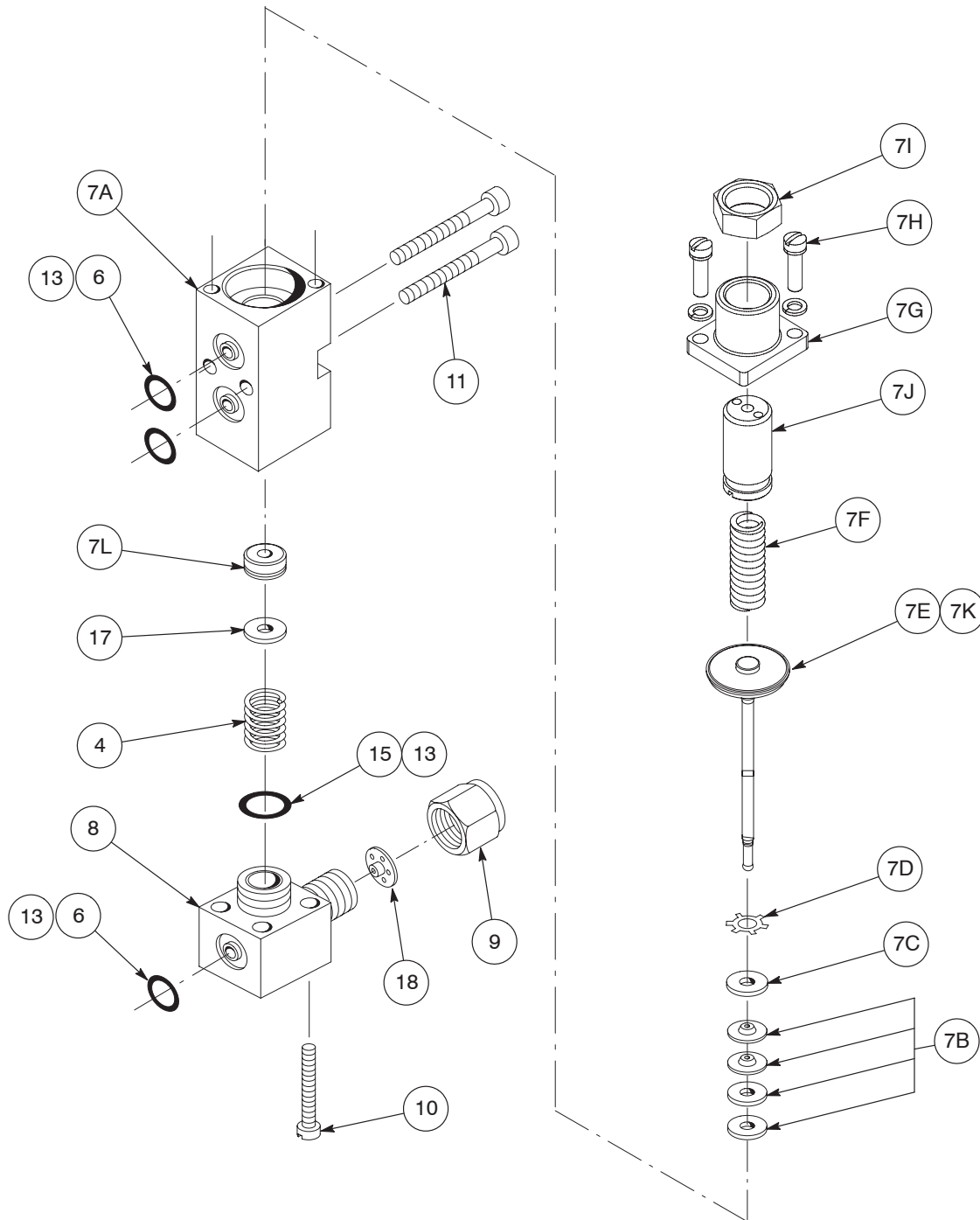

Figure 9-28 Right-angle CF200PAD module parts

## Nozzle Part Numbers

Normally, the choice of nozzle for your applicator will have already been made by you and your Nordson representative. Refer to your sales order to determine what nozzle choices were made. The part numbers for the most commonly used nozzles are provided here.

There are two types of CF nozzle, as shown in Table 9-2. CF nozzles may have either 6 air openings or 12 air openings. Nozzles with 12 air openings are referred to as high-frequency nozzles.

Table 9-2 Types of CF Nozzle

CF Nozzle Type	Description
Disk	The nozzle disk and the nozzle-retaining nut are two separate parts. The disk is held onto the module by the nozzle-retaining nut and is protected from damage because it is recessed inside the nut.
Unibody or steel unibody	The nozzle disk and the nozzle-retaining nut are a single assembly. This design makes the nozzles easier to clean because there are no recessed surfaces (as on disk nozzles). However, the nozzle disks may be more susceptible to damage. The nozzle-retaining nuts on unibody nozzles are color-coded for ease of identification. Steel unibody nozzles are also available.

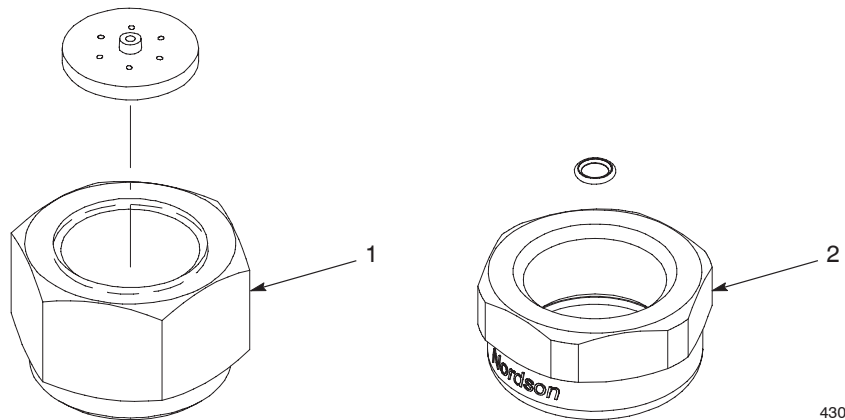

430100012

Figure 9-29 CF nozzles

1. CF disk nozzle (disk exploded)

2. CF unibody nozzle (O-ring exploded)

Table 9-3 CF Disk Nozzles (6 Air Openings)

Orifice Diameter	Pattern Width	Part Number
0.012 in.	Standard	860548
0.014 in.	Standard	860574
0.016 in.	Standard	860575
0.018 in.	Standard	860228
0.018 in.	Wide	1047073
0.018 in.	Wide	1047060
0.020 in.	Standard	860435
0.025 in.	Standard	100728
0.030 in.	Standard	810381
0.030 in.	Wide	1047075
0.050 in.	Standard	810300

**NOTE:** Use nozzle-retaining nut part 119202 with these nozzles.

Table 9-4 High-Frequency CF Disk Nozzle (12 Air Openings)

Orifice Diameter	Pattern Width	Nozzle Part Number
0.018 in.	Standard	755316

**NOTE:** Use nozzle-retaining nut part 119202 with these nozzles.

Table 9-5 CF Unibody Nozzles (6 Air Openings)

Orifice Diameter	Pattern Width	Nozzle Part Number
0.012 in.	Standard	152168
0.012 in.	Wide	1046126
0.014 in.	Standard	152169
0.016 in.	Standard	152170
0.018 in.	Standard	152171
0.018 in.	Wide	1046150
0.020 in.	Standard	152172
0.020 in.	Wide	1046151
0.025 in.	Standard	156698
0.025 in.	Wide	1046152
0.030 in.	Standard	152173
0.030 in.	Wide	1046156
0.040 in.	Standard	162500

**NOTE:** All nozzles include O-ring part 940031.

## Nozzle Part Numbers *(contd)*

Table 9-6 High Frequency CF Unibody Nozzles (12 Air Openings)

Orifice Diameter	Pattern Width	Nozzle Part Number
0.012 in.	Standard	755957
0.012 in.	Narrow	757537
0.014 in.	Standard	756306
0.016 in.	Standard	756307
0.018 in.	Standard	755530
0.018 in.	Wide	1046128
0.020 in.	Standard	756308
0.025 in.	Standard	756309
0.030 in.	Standard	756115
0.030 in.	Wide	1046154
0.046 in.	Standard	757399
0.046 in.	Wide	757469

**NOTE:** All nozzles include O-ring part 940031.

Table 9-7 CF Steel Unibody Nozzles (6 Air Openings)

Orifice Diameter	Pattern Width	Nozzle Part Number	Color
0.012 in.	Standard	753488	Brown
0.014 in.	Standard	753489	Grey
0.016 in.	Standard	753491	Green
0.018 in.	Standard	753492	Blue
0.020 in.	Standard	753493	Red
0.025 in.	Standard	753494	Pink
0.030 in.	Standard	753495	Black
0.018 in.	Wide	1046158	Yellow
0.030 in.	Wide	1046160	Purple
0.040 in.	Standard	753496	Maroon

**NOTE:** All nozzles include O-ring part 940031.

This page intentionally left blank.

## Module Service Kits

See Figure 9-30. Other service kits are available. Contact your Nordson representative for information.

Item	Part	Description	Quantity	Note
—	1055414	Kit, module rebuild, one module, with needle-and-piston assembly (rebuilds one module)	—	
1	150170	• Needle with piston	1	
2	986502	• Retaining ring, internal, 43, push-on	1	
3	983012	• Disk, seal support	2	
4	750553	• Seal, hat, formed	4	
5	117544	• Seal, spring, $\frac{1}{8} \times \frac{7}{16} \times \frac{3}{32}$ in., PTFE	1	
6	940111	• O-ring, Viton, 0.301 ID x 0.070 W in.	3	
7	940121	• O-ring, Viton, 0.364 x ID x 0.070 W in.	1	
8	144892	• Spring, compression, 0.420 x 0.500 in.	1	
9	272823	• Tool, seal	1	
10	272821	• Tool, retaining ring removal	1	
11	272824	• Tool, base	1	
12	1057944	• Tool, piston insertion	1	
NS	272287	• Gasket	1	A
NS	104723	• Instructions, module rebuild	1	
—	1055411	Kit, module rebuild, ten modules, with needle-and-piston assembly (rebuilds ten modules)	—	
1	150170	• Needle with piston	10	
2	986502	• Retaining ring, internal, 43, push-on	10	
3	983012	• Disk, seal support	20	
4	750553	• Seal, hat, formed	40	
5	117544	• Seal, spring, $\frac{1}{8} \times \frac{7}{16} \times \frac{3}{32}$ in., PTFE	10	
6	940111	• O-ring, Viton, 0.301 ID x 0.070 W in.	22	
7	940121	• O-ring, Viton, 0.364 x ID x 0.070 W in.	10	
8	144892	• Spring, compression, 0.420 x 0.500 in.	10	
9	272823	• Tool, seal	1	
10	272821	• Tool, retaining ring removal	1	
11	272824	• Tool, base	1	
12	1057944	• Tool, piston insertion	1	
NS	272287	• Gasket	10	A
NS	104723	• Instructions, module rebuild	1	
—	1055413	Kit, module rebuild, ten modules, without needle-and-piston assembly (rebuilds ten modules)	—	
2	986502	• Retaining ring, internal, 43, push-on	10	
3	983012	• Disk, seal support	20	
4	750553	• Seal, hat, formed	40	
5	117544	• Seal, spring, $\frac{1}{8} \times \frac{7}{16} \times \frac{3}{32}$ in., PTFE	10	
6	940111	• O-ring, Viton, 0.301 ID x 0.070 W in.	22	
7	940121	• O-ring, Viton, 0.364 x ID x 0.070 W in.	10	
8	144892	• Spring, compression, 0.420 x 0.500 in.	10	
9	272823	• Tool, seal	10	
10	272821	• Tool, retaining ring removal	10	
11	272824	• Tool, base	10	
12	1057944	• Tool, piston insertion	10	
NS	272287	• Gasket	10	A
NS	104723	• Instructions, module rebuild	1	

Continued...

Item	Part	Description	Quantity	Note
—	272822	Kit, needle-and-piston assembly and seals	—	
1	150170	• Needle with piston	1	
2	986502	• Retaining ring, internal, 43, push-on	1	
3	983012	• Disk, seal support	1	
4	750553	• Seal, hat, formed	4	
—	147473	Kit, compression springs and seal support discs	—	
10	144892	• Spring, compression, 0.420 x 0.500 in.	6	
A3	983012	• Disc, seal support	6	
—	272290	Kit, needle-and-piston assembly	—	

NOTE A: This gasket is not used on CF200PAD modules.

NS: Not Shown

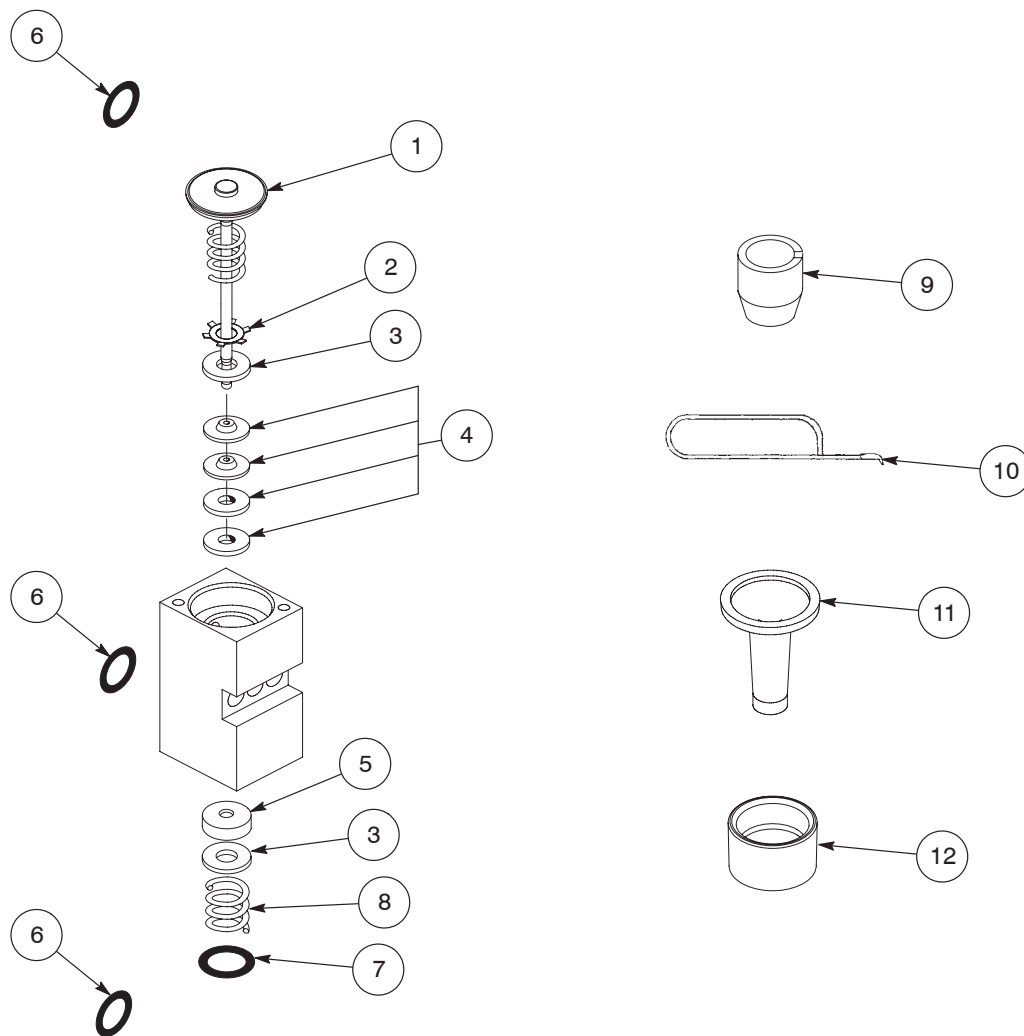

Figure 9-30 Module service kit parts

## Recommended Spare Parts and Supplies

For a general spare parts and supplies list, refer to *Recommended Spare Parts and Supplies* in Section 8, *Parts*.

Part	Description	Note
144906	Module, CF200, spray, pattern air diffuser (PAD), standard	
753166	Module, CF200, spray, pattern air diffuser (PAD), right-angle	
940111	• O-ring, Viton, 0.301 ID x 0.070 W in. (for the back of the module)	
982871	• Screw, socket, 10-32, with O-ring (for securing the module to the applicator)	
-----	Nozzles	A
119202	• Nozzle-retaining nut (for disk nozzles)	
940031	• O-ring, Viton, 0.087 x 0.127 x 0.020 in. (for unibody nozzles)	
133665	Kit, CF unibody nozzle O-rings (contains 10 part 940031 O-rings)	
133664	Kit, CF unibody nozzle O-rings (contains 25 part 940031 O-rings)	
133663	Kit, CF unibody nozzle O-rings (contains 100 part 940031 O-rings)	
901915	Kit, nozzle cleaning, small orifice	
231100	Kit, nozzle cleaning, large orifice	
1059671	Kit, multi-tool, cap/nozzle/filter (for adjusting a module)	
754766	Wrench, torque, CF disk nozzles	
754767	Wrench, torque, CF unibody nozzles	
900223	Lubricant, O-ring, Parker, 4 oz (for lubricating O-rings)	
900344	Lubricant, Never Seez, 8 oz can (for the module socket-head screws)	
900236	Sealant, paste, Teflon (for the seat and air cap screw threads)	
900290	Oil, neat's foot (for the needle-and-piston assembly)	
NOTE A: Refer to <i>Nozzle Part Numbers</i> earlier in this section for a list of available nozzles.		

# Technical Data

## Applicator Specifications

Table 9-8 provides specifications for an applicator with CF200PAD modules. Refer to *Applicator-Specific Reference Drawings* in Section 8, *Parts*, for the following information about your applicator:

- dimensions
- cordset style
- number and orientation of filters
- number of modules
- type and number of solenoid valves

Table 9-8 CF200 Applicator Specifications

Item	Specification
Operating temperature	70–230 °C (160–450 °F)
System hydraulic pressure	14–55 bar (200–800 psi); 103.4 bar (1,500 psi) maximum
Module-actuating air pressure	4.1–6.2 bar (60–90 psi) typical
Pattern air pressure	0.3–3.4 bar (5–50 psi); 0.8–1.2 bar (12–18 psi) typical
Pattern air temperature	9–15 °C (15–25 °F) above the adhesive application temperature; 15 °C (25 °F) typical
Air consumption	~28.3 nlm (~1 scfm) per module
Adhesive viscosity	500–10,000 cps
Adhesive pattern capability	Continuous or intermittent
Adhesive fiber size	10–200 microns
Adhesive add-on weight	1–2 gsm @ 300 m/min (984 ft/min)
Nozzle selection	CF disk, unibody, and steel unibody
Coating width (see Note)	Standard nozzle: 6–32 mm (0.25–1.25 in.) Wide nozzle: 25–51 mm (1.0–2.0 in.)
Size of nozzle openings	Refer to <i>Nozzle Part Numbers</i> .
Mounting height	19–51 mm (0.75–2.0 in.) typical
<b>NOTE:</b> The adhesive pattern width is affected by the viscosity of the adhesive. Lower-viscosity adhesives may not produce patterns as wide as those listed.	

## Torque Specifications

These torque specifications are also stated within the appropriate procedures.

Item	Torque Specification
CF disk nozzles	3.4 N•m (30 in.-lb)
CF unibody nozzles	0.6 N•m (5 in.-lb)
Module mounting screws	3.4 N•m (30 in.-lb)
Air cap screws	1.5–1.7 N•m (13–15 in.-lb)
Seat retaining screws	1.8–2.0 N•m (16–18 in.-lb)

## Module Dimensions

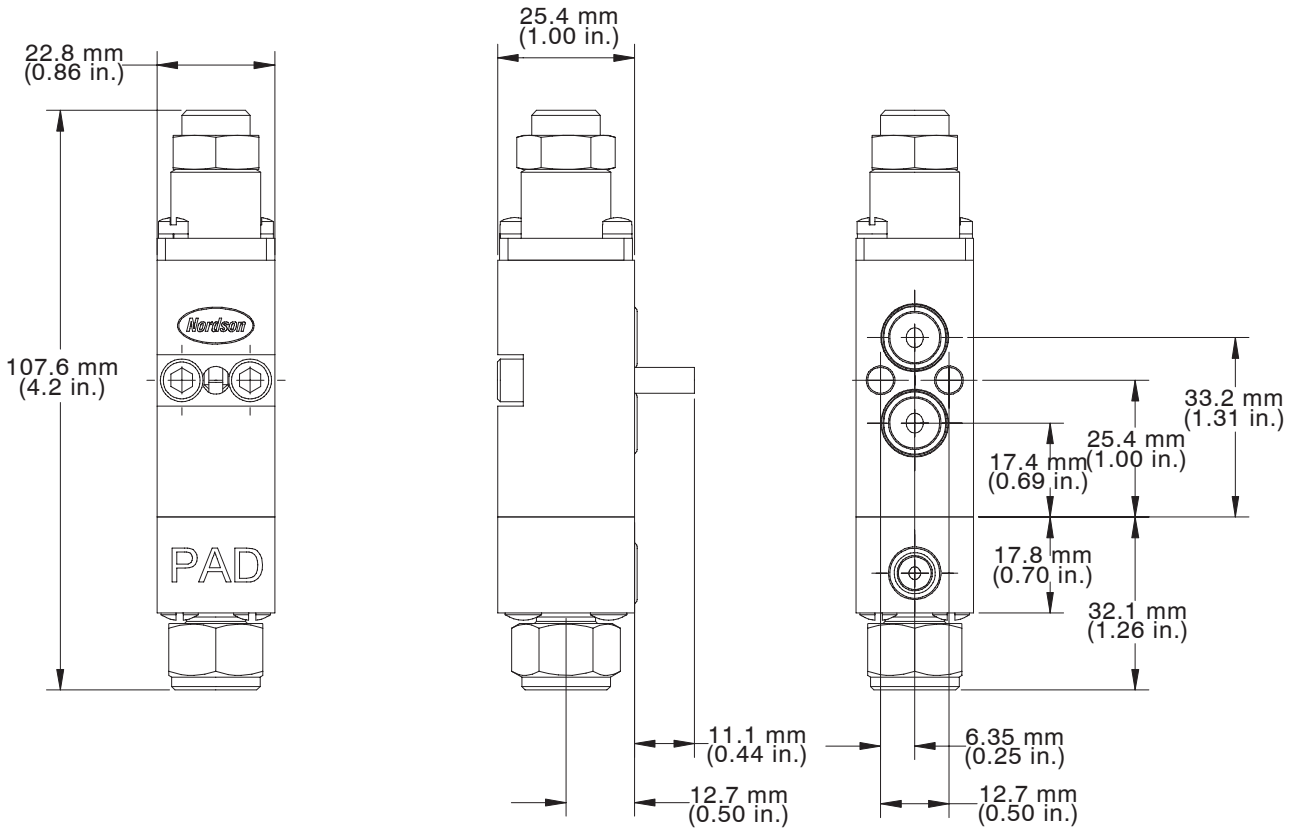

Figure 9-31 Standard CF200PAD module dimensions

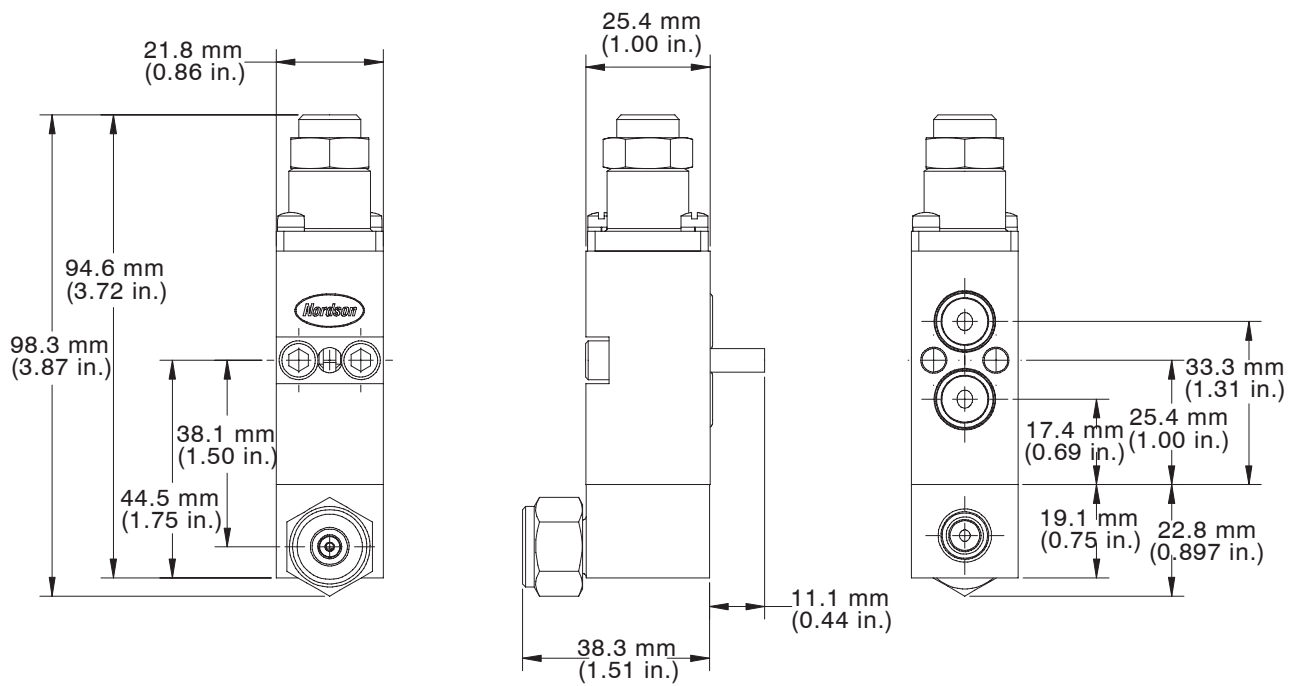

Figure 9-32 Right-angle CF200PAD module dimensions

