

Section 9

Module

NOTE: This section applies to applicators with UM22 modules.

Table of Contents

Module	9-1
Introduction	9-3
Module Overview	9-6
Pattern Control Troubleshooting	9-8
Module Service	9-12
Synchronizing Multi-Module Applicator Adhesive Output	9-12
Replacing a Module	9-14
Remove the Module	9-14
Install the Module	9-15
Rebuilding a Module	9-16
Disassemble the Module	9-16
Reassemble the Module	9-19
Nozzle Service	9-22
Removing a Nozzle	9-22
Installing a Nozzle	9-24
Cleaning Nozzles	9-25
Parts	9-29
UM22 Module Parts	9-30
Adjustable Modules	9-30
Fixed Modules	9-32
OptiStroke Modules	9-34
Blank Module	9-36
Adjustable Air Cap	9-37
Fixed Air Cap	9-38
OptiStroke Air Cap	9-39
Nozzle-Retaining Clamp (Standard)	9-40
Nozzle-Retaining Clamp (Right-Angle)	9-41
Summit Elastic Guide Parts	9-42
Elastic Guide	9-42
Elastic Guide Rollers	9-44

Module (contd)	
Nozzle Adapter Part Numbers	9-45
Nozzle Part Numbers	9-46
CF Disk and Unibody Nozzles	9-46
Universal CF Nozzles	9-49
Meltblown Nozzles	9-50
Summit Nozzles	9-52
SureWrap Nozzles	9-53
Signature Nozzles	9-54
Blank Nozzle	9-56
Module Service Kits	9-57
Recommended Spare Parts and Supplies	9-59
Technical Data	9-60
Applicator Specifications	9-60
Torque Specifications	9-61
Module Dimensions	9-61

WARNING: Allow only personnel with appropriate training and experience to operate or service the equipment. The use of untrained or inexperienced personnel to operate or service the equipment can result in injury, including death, to themselves and others, and damage to the equipment.

Introduction

This section provides troubleshooting, repair, parts, and specification information for applicators with UM22 Universal modules. The UM22 module, either directly or through the use of an adapter, can dispense adhesive in a variety of spray applications, including Controlled Fiberization (CF), meltblown, Summit, and SureWrap applications. Table 9-1 shows the available UM22 modules. Figures 9-1 and 9-2 show the key components of the UM22 module parts family.

Table 9-1 UM22 Modules

Part Number	Orientation	Construction	Actuation Type	Air Cap Type
1048999	Standard	Aluminum	AOSC	Adjustable
1049482	Standard	Aluminum	AOSC	Fixed
1049137	Standard	Aluminum	AOSC	OptiStroke
1054932	Right-angle	Aluminum	AOSC	Adjustable
1063255	Standard	Aluminum	Blank	Not applicable

NOTE: AOSC stands for air-open, spring-close.

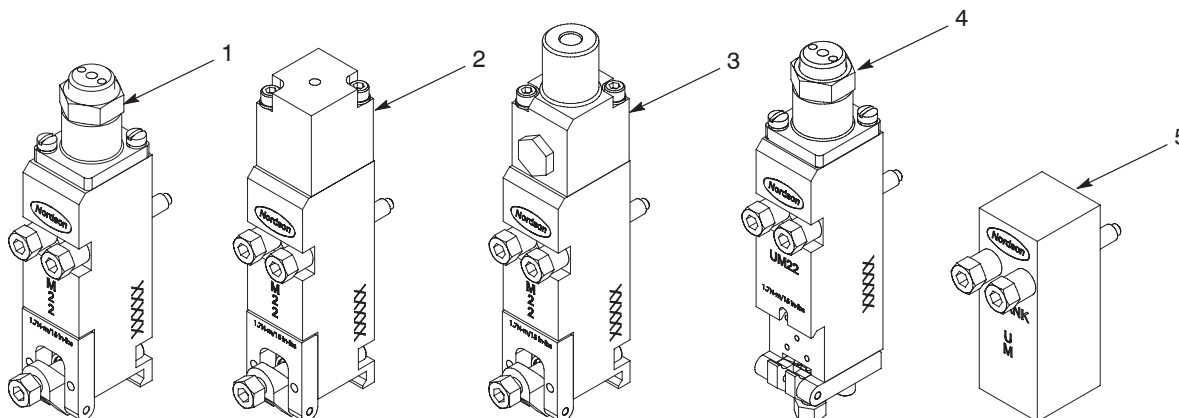

Figure 9-1 Example UM22 modules

- 1. Standard module, adjustable
- 2. Standard module, fixed
- 3. Standard module, OptiStroke
- 4. Right-angle module, adjustable
- 5. Blank module

Introduction *(contd)*

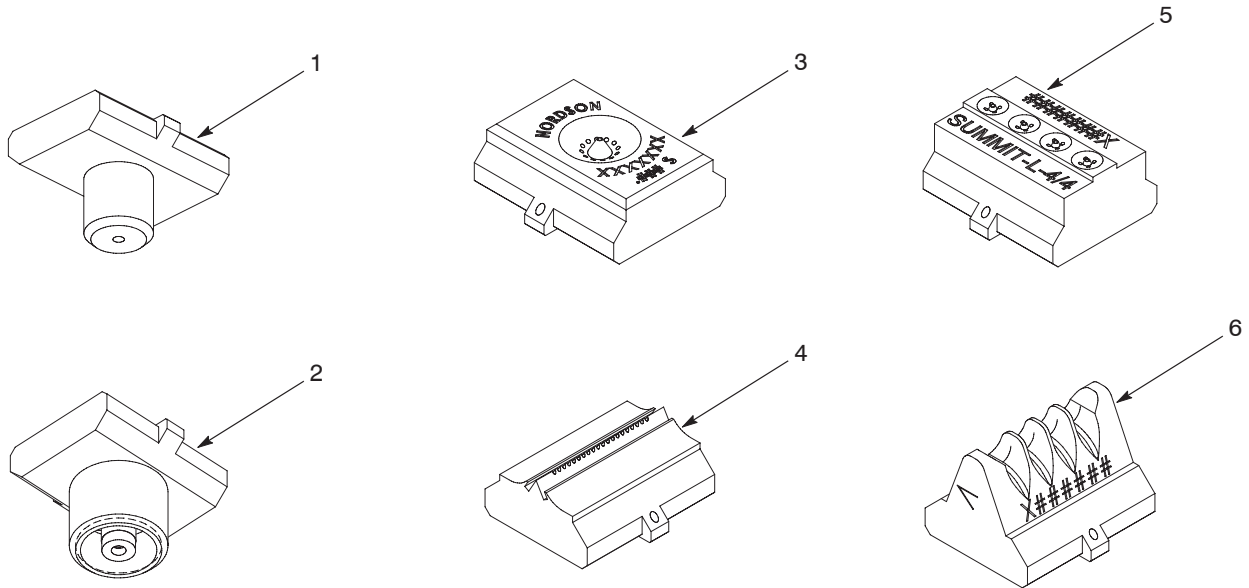

Figure 9-2 Adapters and nozzles associated with UM22 modules

- | | | |
|---|--------------------------|-------------------------|
| 1. Bead adapter (for bead nozzles) | 3. Universal CF nozzle | 5. UM22 Summit nozzle |
| 2. CF adapter (for CF disk and unibody nozzles) | 4. UM22 meltblown nozzle | 6. UM22 SureWrap nozzle |

Note: The bead adapter is used in non-spray applications, which are not covered by this manual. For more information on the use of this adapter, contact your Nordson representative.

Note: No adapter is required for Universal CF, meltblown, Summit, and SureWrap nozzles.

This page intentionally left blank.

Module Overview

Dispensing modules apply adhesive to a product. All modules are air-actuated (or air-open), meaning that an air supply controlled by a solenoid valve is required to open the module. Modules are then spring-closed. In air-open, spring-close (AOSC) modules, the actuating air lifts a needle-and-piston assembly inside the module, thus opening the module and allowing adhesive to flow through the nozzle onto the product. When the actuating air shuts off, a spring returns the needle-and-piston assembly to the closed position, closing the module.

A separate air supply is used to supply pattern air to the module; this air enters the pattern air inlet and is directed onto the adhesive exiting the nozzle, creating the desired spray pattern.

UM22 OptiStroke modules are compatible with the OptiStroke needle detection system. The special OptiStroke air cap on the module accepts the required sensor. The OptiStroke needle detection system electronically verifies the opening and closing time of a module/valve combination. It is used as a service and maintenance tool to measure compensation times and sends an alarm or stops the line during a stroke fault. The detection system automatically prevents production loss due to the absence of adhesive on the substrate caused by a slow or non-operating module/valve. Contact your Nordson representative for additional information on the OptiStroke needle detection system.

Figure 9-3 shows the flow of adhesive and air through a UM22 module. Figure 9-4 shows the key parts of a module.

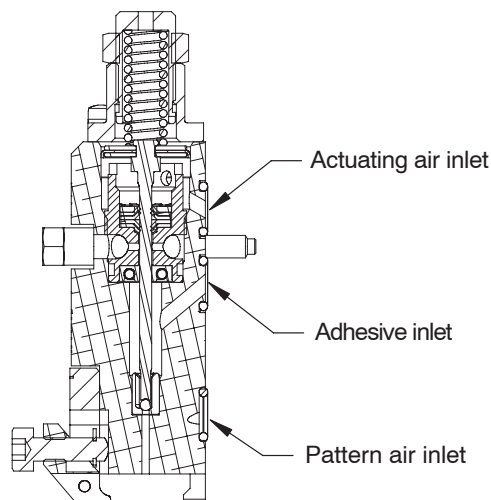

Figure 9-3 Flow of adhesive and air through a UM22 module (adjustable module shown)

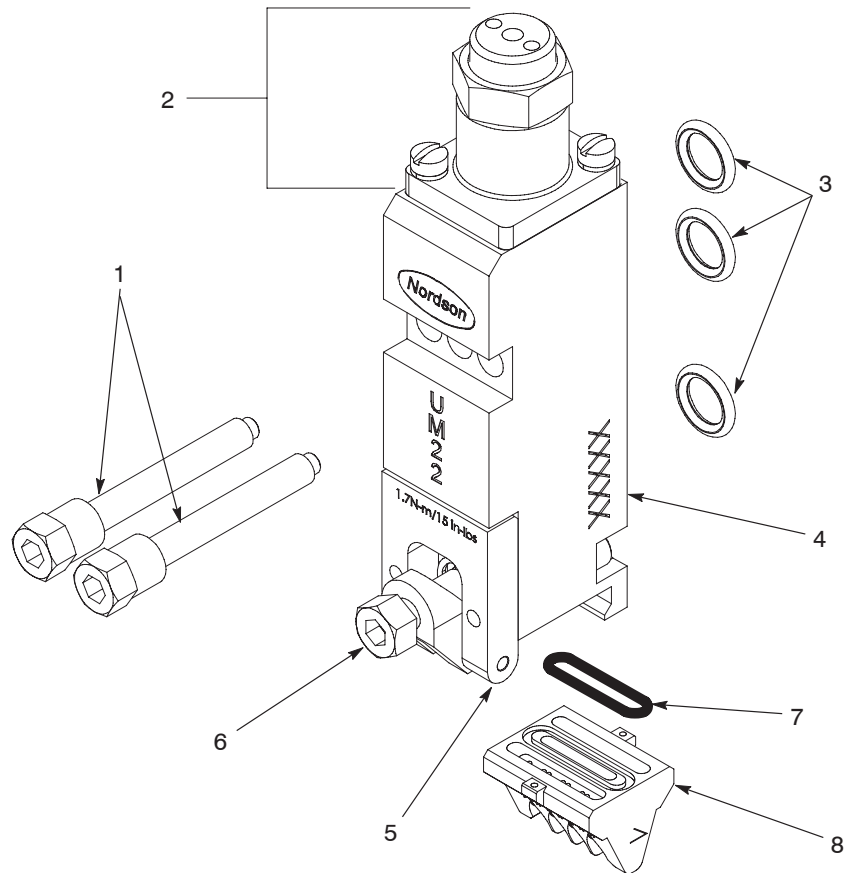

Figure 9-4 Key parts of a UM22 module (standard adjustable module shown)

- | | |
|--|-----------------------------------|
| 1. Module mounting screws | 5. Nozzle-retaining clamp |
| 2. Air cap assembly (adjustable air cap shown) | 6. Nozzle-retaining clamp screw |
| 3. Module O-rings | 7. Nozzle O-ring |
| 4. Module body | 8. Nozzle (SureWrap nozzle shown) |

Pattern Control Troubleshooting

Use this troubleshooting table if you are experiencing adhesive pattern control problems. For all other troubleshooting, refer to Section 6, *Troubleshooting*.

NOTE: Some of the problems listed in this troubleshooting table may not apply to the adhesive application you are troubleshooting. Contact your Nordson representative as needed for troubleshooting assistance.

NOTE: To aid in detecting pattern control problems, direct a strobe light on the adhesive as it flows onto the product.

Problem	Possible Cause	Corrective Action
1. Pattern off-center (skewed) or gaps in pattern	Blocked adhesive or air passages in nozzle	Clean or replace the nozzle. Refer to <i>Nozzle Service</i> . If cleaning or replacing the nozzle does not improve the pattern, check for blockages in the module, applicator, or hose. Refer to <i>Checking for Blockages</i> in Section 6, <i>Troubleshooting</i> .
2. End pattern oriented toward center of applicator	Air currents in area near module	Eliminate the air current or add a blank module that provides only pattern air next to the end module.
3. Adhesive droplets thrown from adhesive stream/pattern breaking up (overspray)	Adhesive and/or pattern air temperature too hot Pattern air pressure too high Adhesive output rate too low Damaged nozzle (adhesive leaking into air passages and being blown into the pattern) Applicator too far from product Adhesive patterns overlapping and interfering with one another	Adjust the temperature settings. Refer to <i>Applicator Specifications</i> for temperature recommendations. Decrease the pattern air pressure. Increase the system pressure or troubleshoot the output rate problem at the melter. Check for blockages in the nozzle, applicator, or hose. Refer to <i>Checking for Blockages</i> in Section 6, <i>Troubleshooting</i> . Replace the nozzle. Refer to <i>Nozzle Service</i> . Adjust the applicator mounting height. Replace the nozzles on the modules that are producing adhesive streams that interfere with the other module adhesive streams.

Continued...

Problem	Possible Cause	Corrective Action
4. All patterns too narrow	Adhesive and/or pattern air temperature too cool Pattern air pressure too low Applicator too close to product Adhesive flow rate too high	Adjust the temperature settings. Refer to <i>Applicator Specifications</i> for temperature recommendations. Increase the pattern air pressure. Adjust the applicator mounting height. Decrease the system pressure or troubleshoot the output rate problem at the melter.
5. One pattern too narrow	System pressure too high Incorrect or damaged nozzle Blocked air passage in nozzle Blocked air passage in module or heated air manifold	Reduce the system pressure or clean the nozzles. Refer to <i>Cleaning Nozzles</i> . Verify that the nozzle part number is correct. Replace damaged nozzles. Refer to <i>Nozzle Part Numbers</i> or <i>Nozzle Service</i> . Clean or replace the nozzle. Refer to <i>Nozzle Service</i> . Check for blockage in the pattern air path.
6. All patterns too wide	Adhesive and/or pattern air temperature too hot Pattern air pressure too high Applicator too far from product Adhesive flow rate too low Nozzle adhesive opening too large	Adjust the temperature settings. Refer to <i>Applicator Specifications</i> for temperature recommendations. Decrease the pattern air pressure. Adjust the applicator mounting height. Increase the system pressure or troubleshoot the output rate problem at the melter. Change to a nozzle with a smaller adhesive opening. Refer to <i>Nozzle Part Numbers</i> .
7. One pattern too wide	Incorrect or damaged nozzle Blocked adhesive or air passages in nozzle	Verify that the nozzle part number is correct. Replace damaged nozzles. Refer to <i>Nozzle Part Numbers</i> or <i>Nozzle Service</i> . Clean or replace the nozzle. Refer to <i>Nozzle Service</i> .
8. Irregular pattern or adhesive leakage on one module	Nozzle O-ring missing or nozzle too loose (under-tightened) NOTE: CF disk nozzles do not have an O-ring.	Install a new nozzle O-ring, replace the nozzle, or tighten the nozzle-retaining clamp screw. Refer to <i>Nozzle Service</i> .
<i>Continued...</i>		

Pattern Control Troubleshooting *(contd)*

Problem	Possible Cause	Corrective Action
9. Adhesive flow not cutting off properly, causing a poor adhesive pattern	Worn or charred module ball and/or seat	Replace the module. Refer to <i>Replacing a Module</i> .
	System pressure too high	Decrease the system pressure.
10. (Adjustable modules only) Beginnings and ends of adhesive patterns on multi-module applicator not aligned	Modules not synchronized (loading screws not properly adjusted)	Adjust the module loading screws. Refer to <i>Synchronizing Multi-Module Applicator Adhesive Output</i> .
11. (Meltblown only) Individual adhesive streams on a module are wider than other streams	Adhesive and/or pattern air temperature too cool or mounting height out of adjustment	Adjust the settings to the last good run settings and/or check the applicator mounting height.
	Pattern air pressure too low	Increase the pattern air pressure.
12. (Meltblown only) Fibers too fine, cobwebbing on machine surfaces	Applicator temperature and air pressure settings or mounting height out of adjustment	Adjust the settings to the last good run settings and/or check the applicator mounting height.
	Pattern air pressure too high	Decrease the pattern air pressure.
13. (Meltblown only) Fibers too coarse, pattern too open	Applicator temperature and air pressure settings or mounting height out of adjustment	Adjust the settings to the last good run settings and/or check the applicator mounting height.
	Pattern air pressure too low	Decrease the pattern air pressure.

This page intentionally left blank.

Module Service

This part of Section 9 provides module-related service procedures.

Synchronizing Multi-Module Applicator Adhesive Output

NOTE: This procedure applies only to adjustable modules. Fixed and OptiStroke modules are not adjustable.

A loading screw located in the top of the modules can be used to fine-tune the alignment of the adhesive patterns of multi-module applicators, as shown in Figure 9-5.

You will need the following items:

- $\frac{5}{8}$ -in wrench
- cap/nozzle/filter multi-tool (part 1059671)

NOTE: Refer to *Parts* for the part numbers of parts, tools, and supplies.

CAUTION: Do not use the loading screw to increase or decrease the amount of adhesive output (flow rate). To change the flow rate, adjust the melter pump speed.

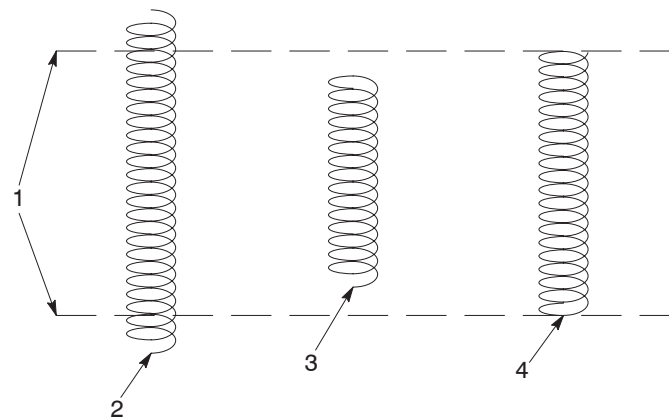

420405008

Figure 9-5 Results of module loading screw adjustments

- | | |
|---------------------|---------------------------|
| 1. Target area | 3. Pattern too short |
| 2. Pattern too long | 4. Desired pattern length |

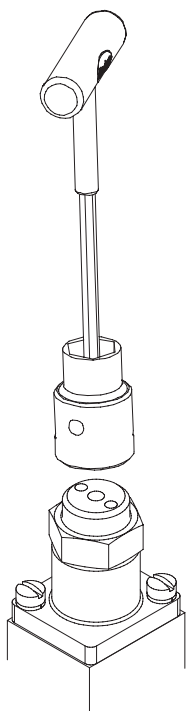

Using the multi-tool, part 1059671, to adjust a module

See Figure 9-6. To adjust a loading screw, loosen the locking nut (2) at the top of the module and hold it loosely in place with a $\frac{5}{8}$ -in wrench while turning the loading screw (1) with the multi-tool; then tighten the locking nut. Turn the loading screw as follows:

- To decrease the length of a pattern, turn the loading screw clockwise. This shortens the length at both ends of the pattern.
- To increase the length of a pattern, turn the loading screw counterclockwise. This increases the length at both ends of the pattern.

NOTE: If the module loading screw is tightened too much, the module will not dispense any adhesive.

To return a loading screw to the factory setting, loosen the locking nut, turn the screw clockwise until it bottoms out, back the screw out three full turns (counterclockwise), and tighten the locking nut.

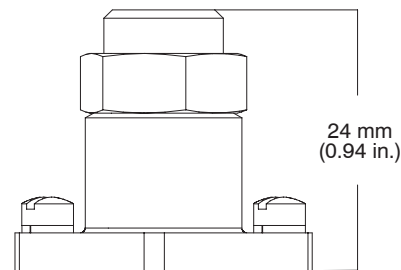
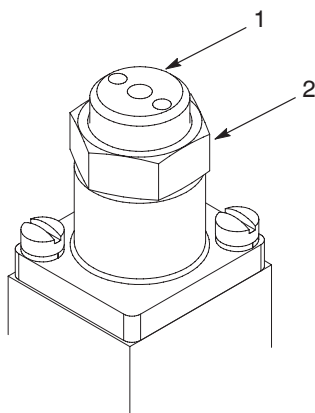

Figure 9-6 Location of the module loading screw and locking nut

1. Loading screw

2. Locking nut

Replacing a Module

You will need the following items:

- appropriate tools, including a torque wrench
- drain pans and disposable rags
- replacement module
- replacement O-rings (if needed)
- O-ring lubricant (if needed)
- anti-seize lubricant

NOTE: Refer to *Parts* for the part numbers of parts, tools, and supplies.

Remove the Module

1. Heat the system to application temperature.
2. Relieve system pressure. Refer to *Relieving System Pressure* in Section 10, *Filter*.
3. Trigger the applicator solenoid valves to relieve any remaining pressure.
4. Shut off the module-actuating air.
5. Decrease the pattern air pressure. Leave just enough air pressure to prevent adhesive from entering the pattern air outlet.
6. See Figure 9-7. Remove the module mounting screws and then remove the module. Discard the module O-rings.

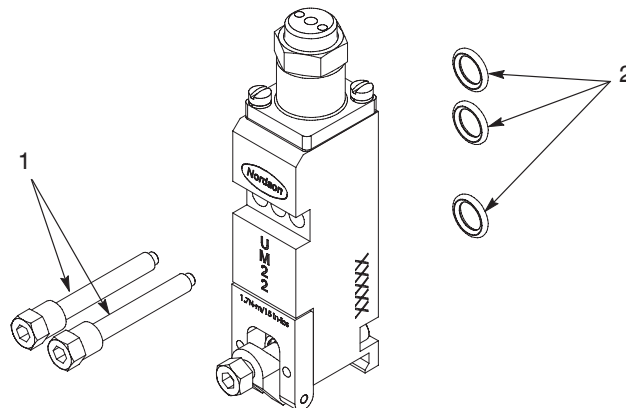

Figure 9-7 Replacing a module (standard adjustable module shown)

1. Module mounting screws

2. Module O-rings

Install the Module

1. Wipe off any adhesive on the applicator, especially around the air passages.
2. Ensure that the module O-rings are lubricated and properly inserted in the O-ring bores on the back of the replacement module.
3. Coat the module mounting screws with anti-seize lubricant and use them to secure the replacement module to the applicator. Tighten the screws to 3.4 N•m (30 in.-lb).
4. Restore the system to normal operation. For best results, tighten the module mounting screws again after the applicator reaches application temperature.

Rebuilding a Module

Two module rebuild kits are available: a minor rebuild kit and a major rebuild kit. The minor rebuild kit includes only the cartridge assembly and the O-rings on the back of the module. The major rebuild kit includes the cartridge assembly, the O-rings, the needle-and-piston assembly, and the compression spring located inside the air cap assembly.

You will need the following items:

- a set of metric Allen (hex) wrenches
- module rebuild tools (cartridge, piston insertion, and base tools)
- drain pans and disposable rags
- module rebuild kit (major or minor)
- Teflon paste
- Neat's foot oil
- anti-seize lubricant
- O-ring lubricant
- special grease (for OptiStroke modules only)

NOTE: Refer to *Parts* for the part numbers of parts, tools, and supplies.

Disassemble the Module

1. To ease module disassembly, ensure that the adhesive in the system is heated at least to the softening point.
2. Relieve system pressure and disable the applicator. Refer to *Relieving System Pressure* in Section 10, *Filter*, as needed.

WARNING: Molten material! Wear eye or face protection, clothing that protects exposed skin, and heat-protective gloves when servicing equipment that contains molten hot melt. Even when solidified, hot melt can still cause burns. Failure to wear appropriate personal protective equipment can result in personal injury.

3. Remove the nozzle and adapter (if applicable) from the module to be rebuilt. Refer to *Removing a Nozzle* later in this section as needed.
4. Remove the module from the applicator and remove and discard the module O-rings. Refer to *Remove the Module* earlier in this section as needed.

- See Figure 9-8. Remove the air cap assembly. If you are doing a major rebuild, remove and discard the compression spring.

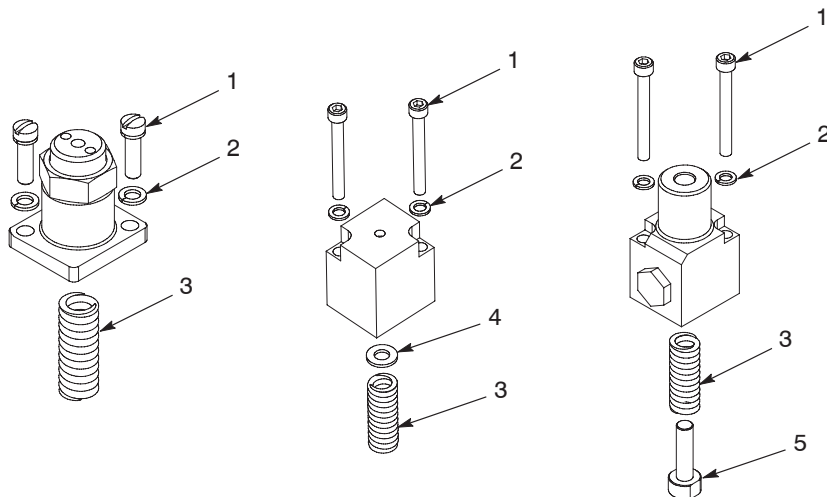

Figure 9-8 Air cap assembly components (adjustable, fixed, and OptiStroke air caps shown)

- | | |
|--------------------------|----------------|
| 1. Socket-head cap screw | 4. Flat washer |
| 2. Lock washer | 5. Piston |
| 3. Compression spring | |

- See Figure 9-9. Carefully push out the needle-and-piston assembly by inserting a small hex wrench in the hole in the bottom of the module.

NOTE: The adhesive in the module should be soft to facilitate this step and to avoid potential damage to the module components.

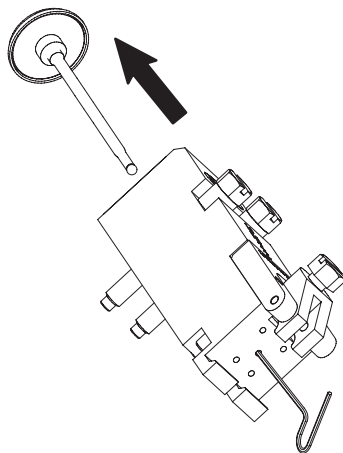

Figure 9-9 Removing the needle-and-piston assembly

421400016

Disassemble the Module (contd)

7. See Figure 9-10. Use the cartridge tool from the module rebuild tool kit to unscrew the cartridge assembly.

NOTE: The adhesive in the module should be soft to facilitate this step and to avoid potential damage to the module components.

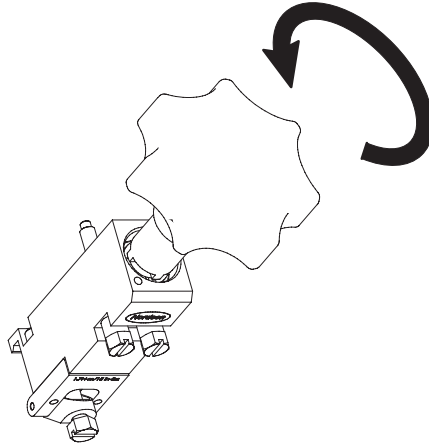

421400017

Figure 9-10 Loosening the cartridge assembly

8. See Figure 9-11. Remove the cartridge assembly from the module body.

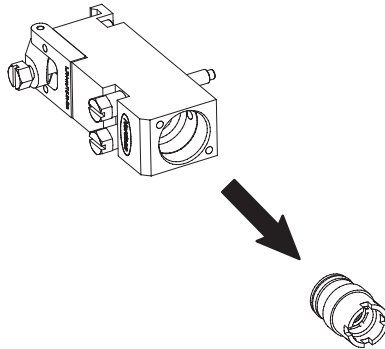

421400018

Figure 9-11 Removing the cartridge assembly

CAUTION: Before using any cleaning or flushing compound on or in the equipment, read and comply with the manufacturer's instructions and the MSDS supplied with the compound. Some cleaning compounds can react unpredictably with hot melt or cold adhesive, resulting in damage to the equipment.

CAUTION: Risk of equipment damage. Do not use any cleaning method (scraping, abrasive blasting, etc.) that could damage the inside surfaces of the module.

9. Soak the module body in a cleaning solution approved for your adhesive type and facility.

Reassemble the Module

1. See Figure 9-12. Apply a light coat of Teflon paste to the new cartridge assembly threads and install the assembly in the module body. Use the cartridge tool to hand-tighten the cartridge assembly until it seats.

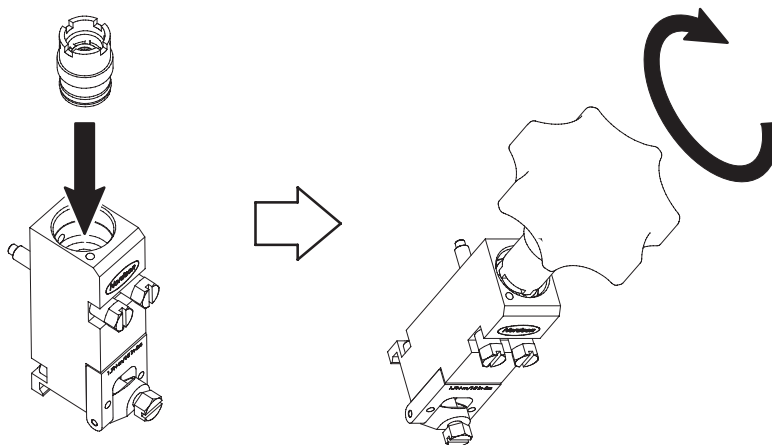

421400019

Figure 9-12 Installing the cartridge assembly

2. See Figure 9-13. Lubricate the seal portion of a new needle-and-piston assembly (1) with neat's foot oil.
3. Stabilize the module body on a flat surface (such as a block or table) and position the piston insertion tool (2) on top of the module body.
4. Drop the needle-and-piston assembly through the piston insertion tool into the module body.

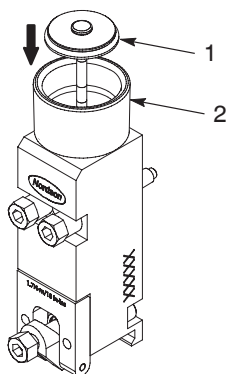

Figure 9-13 Dropping the needle-and-piston assembly through the piston insertion tool into the module body

1. Needle-and-piston assembly

2. Piston insertion tool

Reassemble the Module (contd)

5. See Figure 9-14. Use the base tool to push the needle-and-piston assembly through the seal and into the bore of the module body until it seats.
6. Remove the piston insertion and base tools.

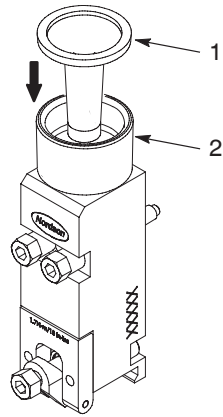

Figure 9-14 Using the base tool to push the needle-and-piston assembly into the module body

1. Base tool
2. Piston insertion tool

7. (*OptiStroke modules only*) If you are rebuilding an OptiStroke module, apply special grease (refer to *Parts*) to the piston portion of the needle-and-piston assembly.

8. See Figure 9-15. Position a reused (minor rebuild) or new (major rebuild) compression spring inside the air cap assembly, apply anti-seize lubricant to the air cap assembly screws, and install the air cap assembly on the module.

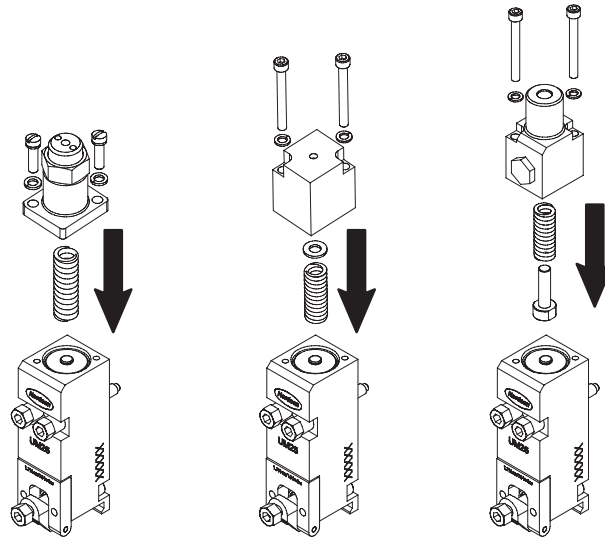

Figure 9-15 Installing the air cap assembly (adjustable, fixed, and OptiStroke air cap assemblies shown)

9. Coat the new module O-rings with O-ring lubricant and place them in the O-ring bores on the back of the module.
10. Reinstall the module on the applicator.
11. Reinstall the adapter (if applicable) and nozzle.
12. Restore the system to normal operation.

Nozzle Service

This part of Section 9 provides nozzle-related service procedures.

Removing a Nozzle

Several types of nozzle may be installed on a Universal module. In some cases, the nozzle is installed on an adapter. Follow this procedure to remove or install nozzles and/or adapters as needed. You will need the following items:

- appropriate tools, including a torque wrench
- drain pans and disposable rags
- replacement adapter and/or nozzle, if applicable

NOTE: Refer to *Parts* for the part numbers of parts, tools, and supplies.

1. Heat the system to application temperature.
2. Relieve system pressure. Refer to *Relieving System Pressure* in Section 10, *Filter*.
3. Trigger the applicator solenoid valves to relieve any remaining pressure.
4. Shut off the module-actuating air.
5. Decrease the pattern air pressure. Leave just enough air pressure to prevent adhesive from entering the pattern air outlet on the module.
6. **To remove a CF disk or unibody nozzle:**

NOTE: A CF disk nozzle is two-piece nozzle that consists of a nozzle disk and a retaining nut. A CF unibody nozzle is a one-piece nozzle.

See Figure 9-16.

- a. Use a wrench to loosen the nozzle-retaining nut.

NOTE: Do not use a torque wrench to loosen or remove a nozzle. Doing so will cause the torque wrench to become uncalibrated.

- b. Remove the nozzle by hand.

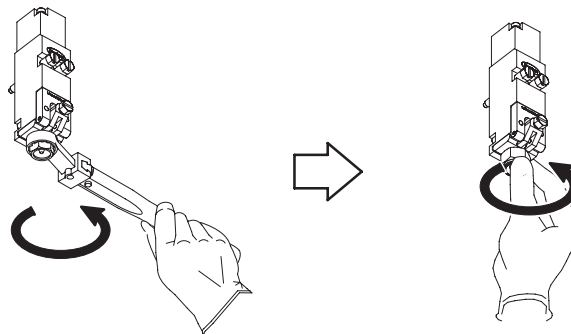

Figure 9-16 Removing a CF disk or unibody nozzle

421400025

7. To remove an adapter or a Universal CF, meltblown, Summit, or SureWrap nozzle:

See Figure 9-17.

- a. Back the nozzle-retaining clamp screw all the way out until it stops.
- b. Push the nozzle-retaining clamp toward the module to eject the adapter or nozzle.

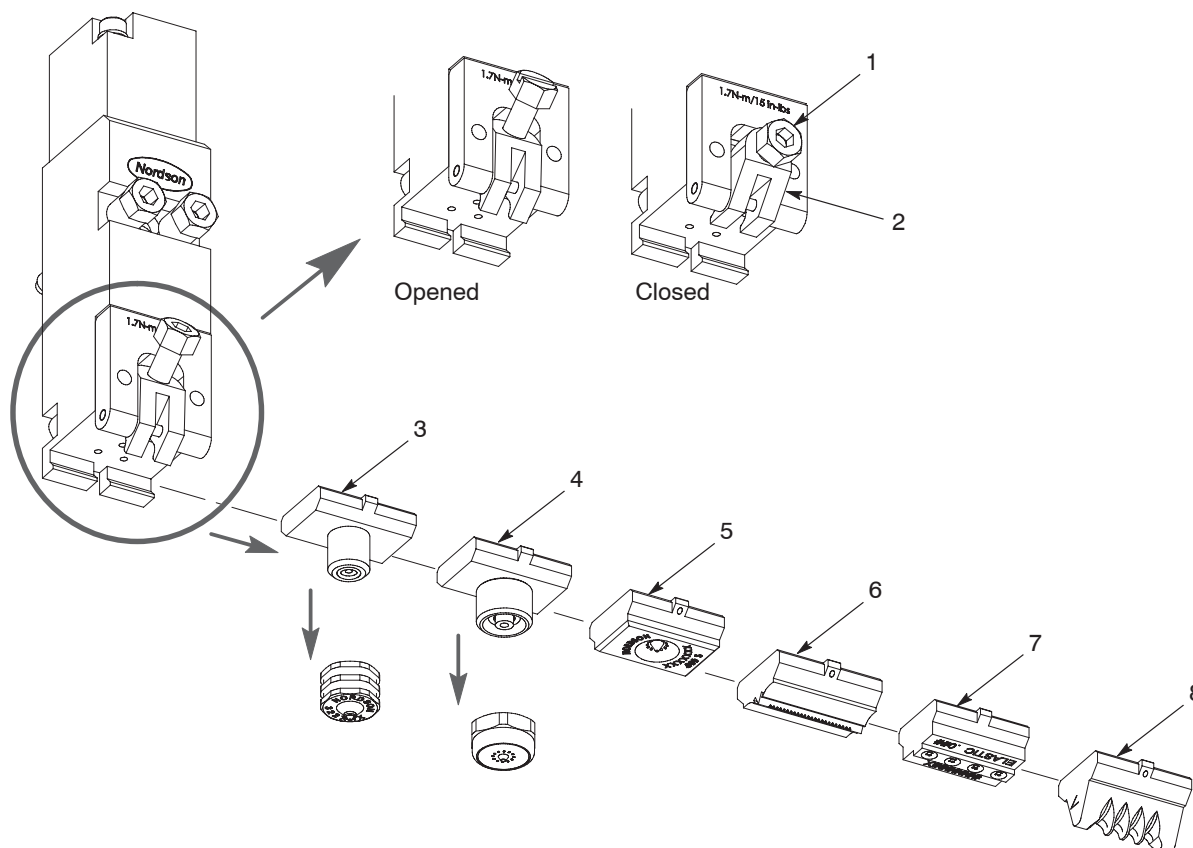

Figure 9-17 Adapter or nozzle removal or installation

- | | | |
|---------------------------------|---|---------------------|
| 1. Nozzle-retaining clamp screw | 4. CF adapter and CF disk or unibody nozzle | 6. Meltblown nozzle |
| 2. Nozzle-retaining clamp | 5. Universal CF nozzle | 7. Summit nozzle |
| 3. Bead adapter and bead nozzle | | 8. SureWrap nozzle |

Note: Refer to the steps under *To remove a CF disk or unibody nozzle* or *To install a CF disk or unibody nozzle* for CF disk and unibody nozzle removal/installation instructions.

Installing a Nozzle

1. Clean the mating surface where the adapter or nozzle will be seated.

2. To install a CF disk or unibody nozzle:

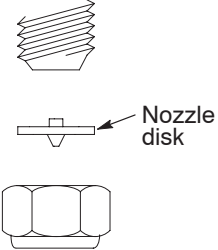
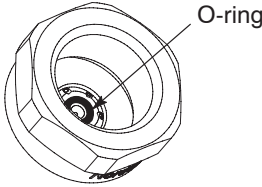
Type of Nozzle	Removal Procedure
<p data-bbox="570 422 711 449">Disk nozzle</p>  <p data-bbox="776 573 862 617">Nozzle disk</p>	<ol style="list-style-type: none"> <li data-bbox="919 422 1414 541">a. Orient the nozzle disk as shown at left and place the disk inside the nozzle-retaining nut; then hand-thread the nut onto the module. <li data-bbox="919 562 1398 621">b. Use a wrench to tighten the nut to no more than 3.4 N•m (30 in.-lb).
<p data-bbox="570 730 756 758">Unibody nozzle</p>  <p data-bbox="824 789 894 816">O-ring</p>	<ol style="list-style-type: none"> <li data-bbox="919 730 1438 825">a. Inspect the nozzle O-ring, replace if necessary, and ensure that the O-ring is lubricated and properly positioned. <li data-bbox="919 846 1390 961">b. Hand-thread the nozzle onto the module. Use a wrench to tighten the nozzle to no more than 0.6 N•m (5 in.-lb).

NOTE: Nordson offers special torque wrenches for CF disk and unibody nozzles. Refer to *Recommended Spare Parts and Supplies* under *Parts*.

3. To install an adapter or a Universal CF, meltblown, Summit, or SureWrap nozzle:

See Figure 9-17.

- a. Inspect the adapter or nozzle O-ring, replace if necessary, and ensure that the O-ring is lubricated and properly positioned in the O-ring bore.
- b. Carefully insert the adapter or nozzle in the module seat.

CAUTION: Overtightening a nozzle-retaining clamp screw can damage the module.

- c. Tighten the nozzle-retaining clamp screw to 1.7 N•m (15 in.-lb).

Cleaning Nozzles

Nozzles should be cleaned weekly or as needed to prevent clogging. You will need the following items:

- appropriate tools, including a torque wrench
- nozzle cleaning kits
- cleaning supplies (refer to Table 9-2)
- drain pans and disposable rags
- O-ring lubricant

NOTE: Refer to *Parts* for the part numbers of parts, tools, and supplies.

1. Remove the nozzles. Refer to the *Removing a Nozzle* earlier in this section.
2. Clean the nozzles using one of the Nordson-recommended methods shown in Table 9-2. Use only cleaning agents recommended by the adhesive supplier.

WARNING: Risk of explosion or fire. Follow the safety guidance and heating recommendations on the Material Safety Data Sheets (MSDSs) for your adhesives and nozzle-cleaning solutions.

WARNING: Risk of explosion or fire. Use a controlled heating device, such as a thermostatically controlled hot plate, to heat cleaning fluid, including Nordson Type-R fluid.

CAUTION: Risk of equipment damage. Do not use a wire brush (or a brush with bristles harder than the nozzle) to clean nozzles.





Cleaning Nozzles *(contd)*

Table 9-2 Nozzle Cleaning Methods

Cleaning Method	Procedure
Citrus-based solution and ultrasonic tank NOTE: This is the most thorough method.	<ol style="list-style-type: none"> a. Place the nozzles in citrus-based solvent/degreasing solution and soak them overnight or for approximately 4 hours. This dissolves and loosens the adhesive and char buildup. b. Remove the nozzles from the citrus-based solvent/degreasing solution and place them in an alkaline solution heated to the appropriate temperature (refer to the MSDS) in an ultrasonic tank. Soak the nozzles for approximately 10 minutes. This will remove adhesive and char from the orifices. c. Scrub the nozzles with a soft, non-metallic brush to remove debris. d. Gently blow air through the nozzle orifices from the mounting side of the nozzle.
Nordson Type-R fluid	<ol style="list-style-type: none"> a. Place the nozzles in a controlled heating device containing Nordson Type-R fluid and heat it above the melting point of the adhesive (refer to the MSDS). b. Scrub the nozzles with a soft, non-metallic brush to remove debris.
Electric heat gun	<ol style="list-style-type: none"> a. Heat the nozzles with a flameless electric heat gun. b. Scrub the nozzles with a soft, non-metallic brush to remove debris.
Ultrasonic tank	<ol style="list-style-type: none"> a. Place the nozzles in an alkaline solution heated to the appropriate temperature (refer to the MSDS) in an ultrasonic tank. Soak the nozzles for approximately 10 minutes. b. Scrub the nozzles with a soft, non-metallic brush to remove debris. c. Gently blow air through the nozzle orifices from the mounting side of the nozzle.

Continued...

Table 9-2 Nozzle Cleaning Methods (contd)

Cleaning Method	Procedure
<p>Oven</p> <p>NOTE: This method will cause discoloration of unplated brass nozzles. This discoloration is cosmetic only and will not adversely affect nozzle performance.</p> <p>NOTE: This method is not recommended for color-coded nozzles (such as Saturn and CF steel unibody nozzles) because it will remove the color from the nozzles.</p>	<div style="display: flex; align-items: flex-start;"> <div style="margin-right: 10px;">  </div> <div> <p>WARNING: Risk of explosion, fire, or toxic vapor release. Depending on the type of adhesive and/or organic solvent used with the nozzles, heating them in an oven can cause a hazardous event. Before using an oven to clean nozzles, consult with the oven manufacturer about the viability of this method and the safety risks. Follow the manufacturer's recommendations.</p> </div> </div> <div style="display: flex; align-items: flex-start; margin-top: 10px;"> <div style="margin-right: 10px;">  </div> <div> <p>WARNING: Use the oven heating controls to keep the oven at the desired temperature. Do not use an oven that does not have heating controls.</p> </div> </div> <div style="display: flex; align-items: flex-start; margin-top: 10px;"> <div style="margin-right: 10px;">  </div> <div> <p>WARNING: The heating temperature and time may need to be adjusted based on the oven type, the adhesive type, and the amount of char buildup on the nozzles. Nordson Corporation recommends testing this procedure on discarded nozzles prior to using it on good nozzles.</p> <p>CAUTION: Risk of equipment damage. Remove O-rings before cleaning nozzles in an oven. Failure to do so can cause a chemical reaction that will permanently damage the nozzles.</p> </div> </div> <ol style="list-style-type: none"> a. Ensuring that O-rings have been removed from the nozzles, place them in an electric oven heated to approximately 385 °C (725 °F). Allow the nozzles to bake for approximately 3–4 hours. b. Turn off the oven and allow the nozzles to cool; then remove the nozzles. <div style="display: flex; align-items: flex-start; margin-top: 10px;"> <div style="margin-right: 10px;">  </div> <div> <p>WARNING: Risk of fire. Use a heat-proof cloth to clean nozzles. Even cotton can burn in high-temperature conditions.</p> </div> </div> <div style="display: flex; align-items: flex-start; margin-top: 10px;"> <div style="margin-right: 10px;">  </div> <div> <p>WARNING: Risk of equipment damage. Handle nozzles carefully to avoid denting the orifices, which can degrade the adhesive pattern.</p> </div> </div> <ol style="list-style-type: none"> c. Wipe the nozzles with a soft cloth and then gently blow air through the nozzle orifices from the mounting side of the nozzle.

Cleaning Nozzles *(contd)*

3. If there is any remaining char buildup on the nozzles, gently scrape the char from the nozzles.

CAUTION: Risk of equipment damage. Use of an open torch, drill, or broach can damage a nozzle. Use only a pin-type probe to clean nozzle orifices and do not twist the probe inside the nozzle.

4. If cleaning of the nozzle orifices is necessary, use a pin-type probe that is one size smaller than the orifice size: insert the probe in the direction opposite the adhesive flow and then remove the probe without twisting it, as shown in Figure 9-18.

NOTE: Nordson offers two nozzle cleaning kits that contain a holder and several probe sizes. Refer to *Recommended Spare Parts and Supplies* under *Parts*.

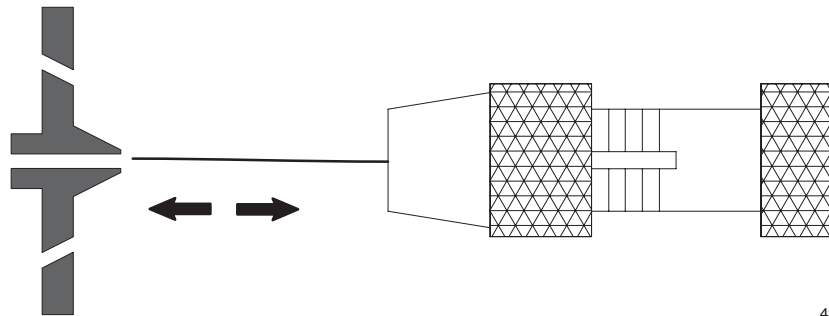

430100013

Figure 9-18 Correct direction to insert a pin-type probe into a nozzle (CF nozzle disk shown)

5. Reinstall the nozzles. Refer to *Installing a Nozzle* earlier in this section.
6. Restore the system to normal operation.

Parts

This part of Section 9 provides detailed parts lists for the module and nozzles. For other applicator parts, including a reference drawing and bill of materials specific to your applicator, refer to Section 8, *Parts*. The following chart provides guidance for reading the parts lists.

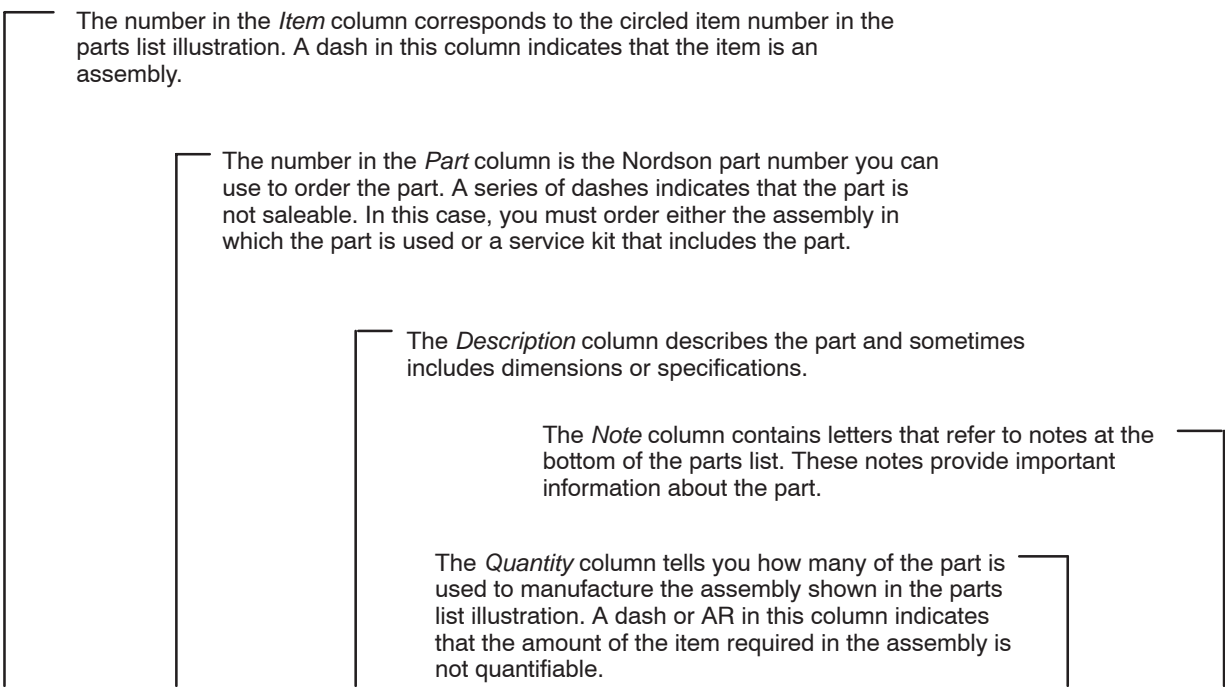

Item	Part	Description	Quantity	Note
—	0000000	Assembly A	—	
1	000000	• Part of assembly A	2	A
2	-----	•• Part of item 1	1	
3	0000000	••• Part of item 2	AR	
NS	000000	•••• Part of item 3	2	
NOTE A: Important information about item 1				
AR: As Required				
NS: Not Shown				

UM22 Module Parts

There are several types of UM22 module. Be sure to refer to the parts lists that apply to your modules. Table 9-1 at the beginning of this section provides an overview of the modules.

Adjustable Modules

See Figure 9-19.

Item	Part	Description	Quantity	Note
—	-----	Module, UM22, adjustable, standard	—	A
NS	-----	Module, UM22, adjustable, right-angle	—	A
1	-----	• Body, standard	1	
2	-----	• Washer, seat	1	
3	-----	• Seat, carbide	1	
4	1048284	• Assembly, cartridge, insert, seal	1	
5	150170	• Needle with piston	1	
6	—	• Item no. not used	—	
7	1048249	• Assembly, air cap, standard, adjustable	1	B
8	-----	• Assembly, clamp, nozzle-retaining	1	C
9	1048244	• Screw, module mounting, 10-32, special	2	
10	—	• Item no. not used	—	
11	940111	• O-ring, Viton, 0.301 ID x 0.070 W in.	3	
NOTE A: Refer to Table 9-1 for module part numbers. B: Refer to <i>Adjustable Air Cap</i> . C: Refer to <i>Nozzle-Retaining Clamp (Standard)</i> or <i>Nozzle-Retaining Clamp (Right-Angle)</i> . NS: Not Shown				

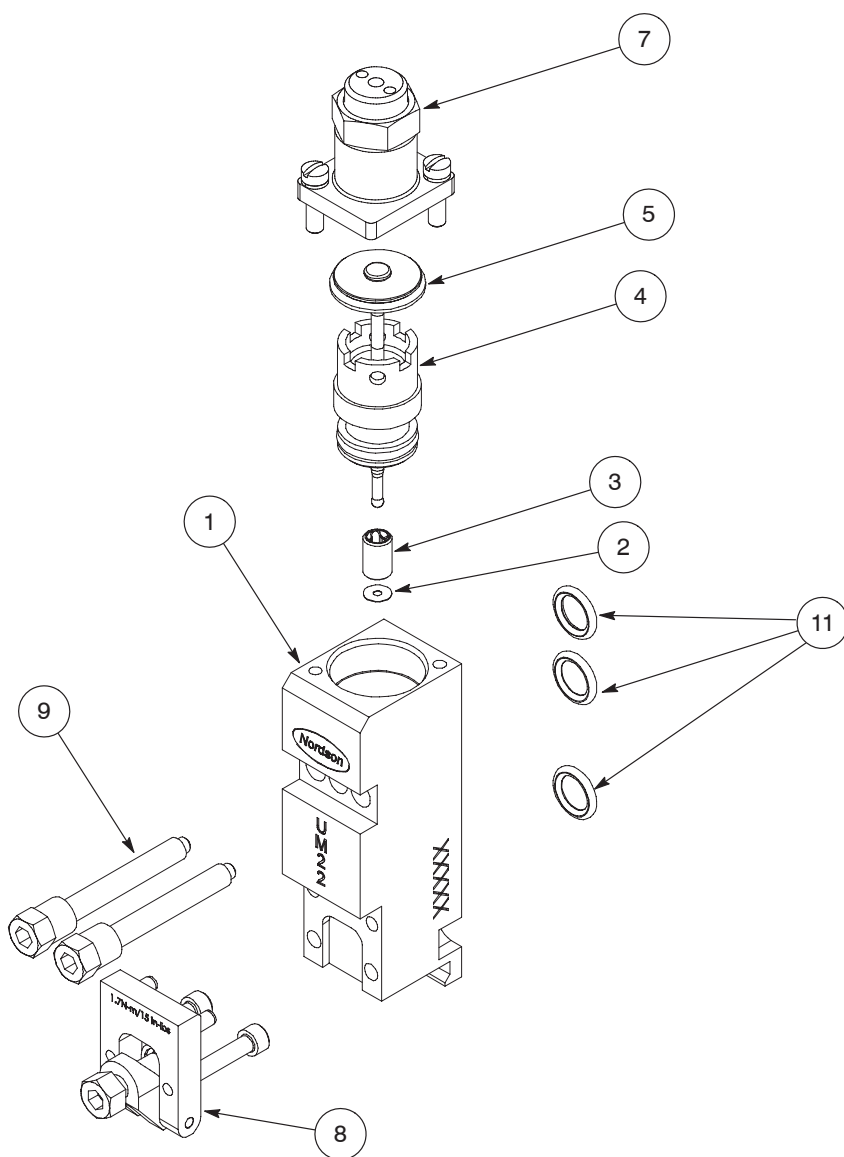

Figure 9-19 UM22 adjustable module parts (standard module shown)

Fixed Modules

See Figure 9-20.

Item	Part	Description	Quantity	Note
—	-----	Module, UM22, fixed, standard	—	A
1	-----	• Body, standard	1	
2	-----	• Washer, seat	1	
3	-----	• Seat, carbide	1	
4	1048284	• Assembly, cartridge, insert, seal	1	
5	150170	• Needle with piston	1	
6	—	• Item no. not used	—	
7	1048704	• Assembly, air cap, fixed	1	B
8	-----	• Assembly, clamp, nozzle-retaining	1	C
9	1048244	• Screw, module mounting, 10-32, special	2	
10	—	• Item no. not used	—	
11	940111	• O-ring, Viton, 0.301 ID x 0.070 W in.	3	
NOTE A: Refer to Table 9-1 for module part numbers. B: Refer to <i>Fixed Air Cap</i> . C: Refer to <i>Nozzle Retaining Clamp (Standard)</i> .				

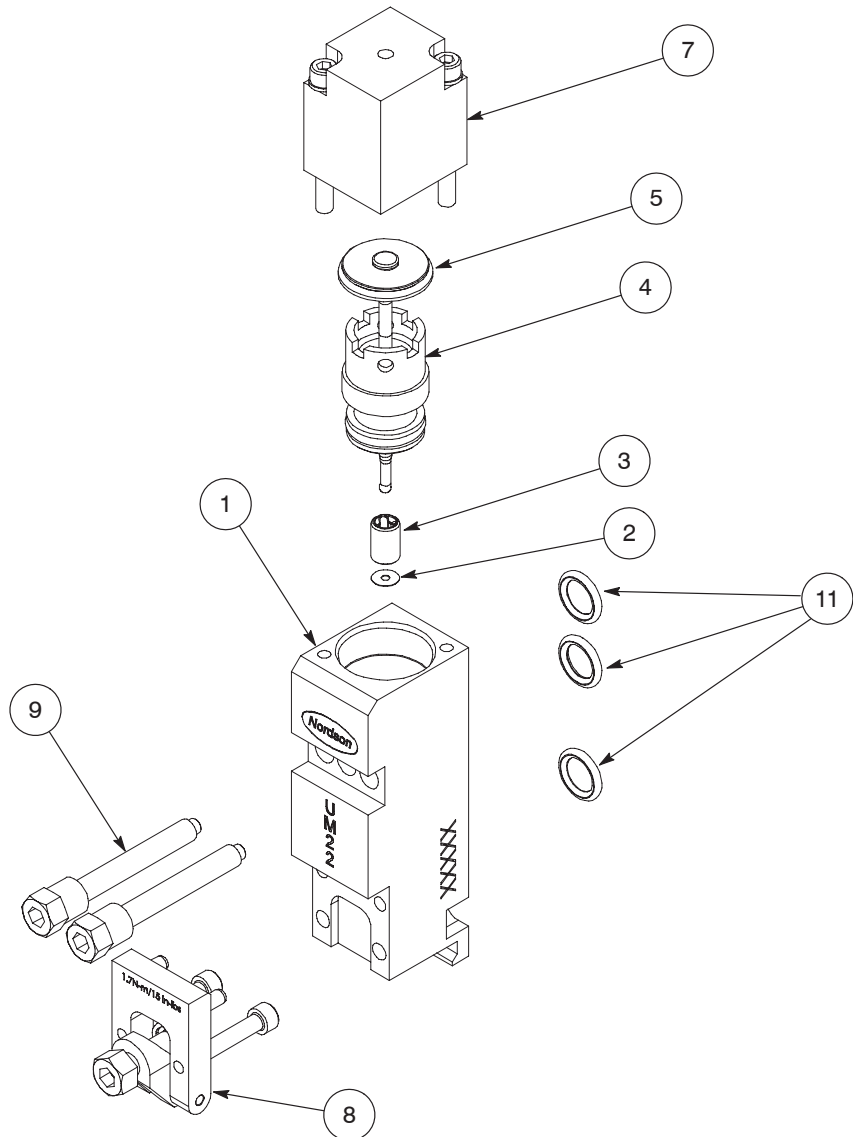

Figure 9-20 UM22 fixed module parts (standard module shown)

OptiStroke Modules

See Figure 9-21.

Item	Part	Description	Quantity	Note
—	-----	Module, UM22, OptiStroke, standard	—	A
1	-----	• Body, standard	1	
2	-----	• Washer, seat	1	
3	-----	• Seat, carbide	1	
4	1048284	• Assembly, cartridge, insert, seal	1	
5	150170	• Needle with piston	1	
6	—	• Item no. not used	—	
7	1049134	• Assembly, air cap, OptiStroke	1	B
8	-----	• Assembly, clamp, nozzle-retaining	1	C
9	1048244	• Screw, module mounting, 10-32, special	2	
10	—	• Item no. not used	—	
11	940111	• O-ring, Viton, 0.301 ID x 0.070 W in.	3	
NOTE A: Refer to Table 9-1 for module part numbers. B: Refer to <i>OptiStroke Air Cap</i> . C: Refer to <i>Nozzle Retaining Clamp (Standard)</i> .				

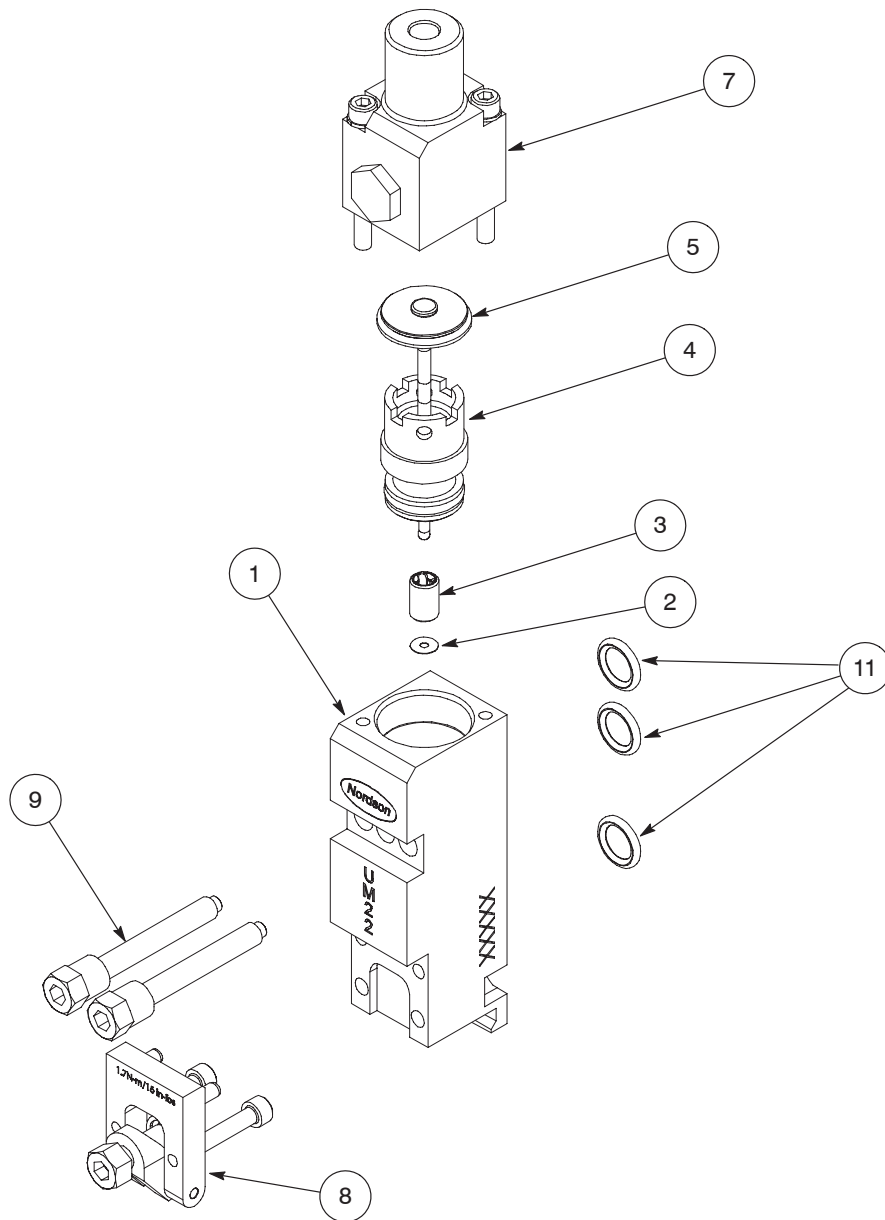

Figure 9-21 UM22 OptiStroke module parts (standard module shown)

Blank Module

See Figure 9-22.

Item	Part	Description	Quantity	Note
—	1063255	Module, UM22, blank	—	
1	-----	• Body, block-off, Universal module	1	
2	940111	• O-ring, Viton, 0.301 ID x 0.070 W in.	3	
3	1048244	• Screw, module mounting, 10-32, special	2	

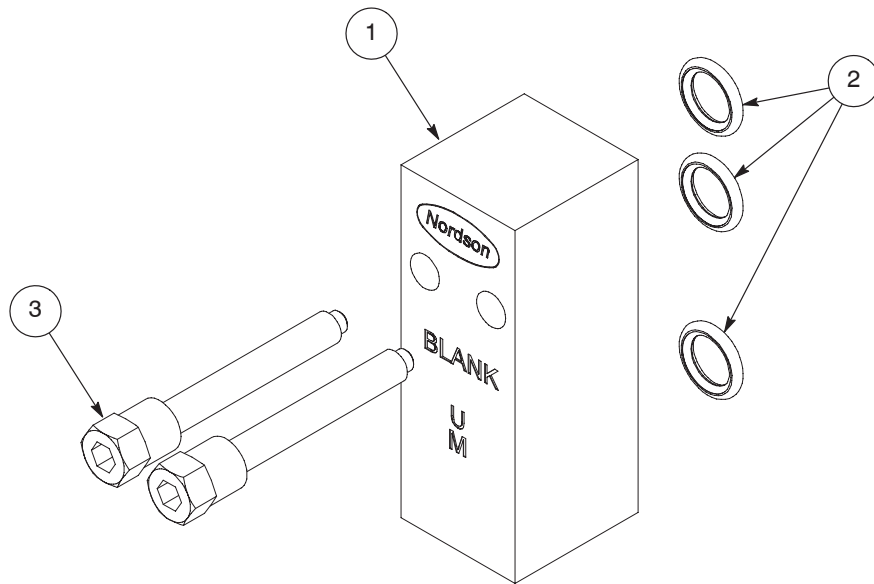

Figure 9-22 UM22 blank module parts

Adjustable Air Cap

See Figure 9-23.

Item	Part	Description	Quantity	Note
—	1048249	Air cap, standard, adjustable	—	
1	-----	• Air cap, adjustable	1	
2	-----	• Screw, spring loading	1	
3	-----	• Nut, locking, 1/2-28	1	
4	-----	• Spring, compression, 1.146 x 0.360 OD x 0.065 in.	1	
5	-----	• Screw, fillister, 6-32 x 0.50 in., with lock washer	2	

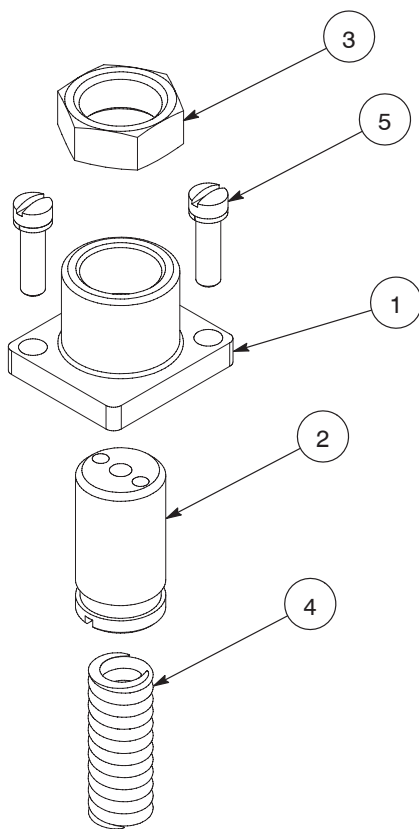

Figure 9-23 Adjustable air cap parts

Fixed Air Cap

See Figure 9-24.

Item	Part	Description	Quantity	Note
—	1048704	Air cap, fixed	—	
1	-----	• Cap, air, non-adjustable	1	
2	-----	• Washer, flat, 0.188 x 0.375 x 0.040 in.	1	
3	-----	• Spring, compression, 1.146 x 0.360 OD x 0.065 in.	1	
4	-----	• Washer, lock, split, #6	2	
5	-----	• Screw, socket, 6-32 x 1.25 in.	2	

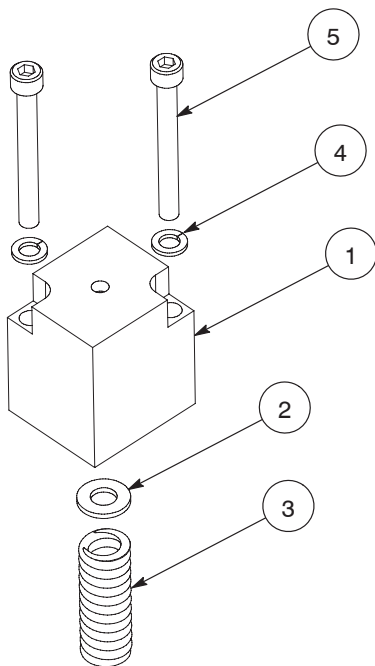

Figure 9-24 Fixed air cap parts

421401015

OptiStroke Air Cap

See Figure 9-25.

Item	Part	Description	Quantity	Note
—	1049134	Air cap, OptiStroke	—	
1	-----	• Cap, air, OptiStroke	1	
2	-----	• Button, piston	1	
3	-----	• Spring, compression, 1.146 x 0.360 OD x 0.065 in.	1	
4	-----	• Washer, lock, split, #6	2	
5	-----	• Screw, socket, 6-32 x 1.25 in.	2	
6	-----	• Silencer	1	

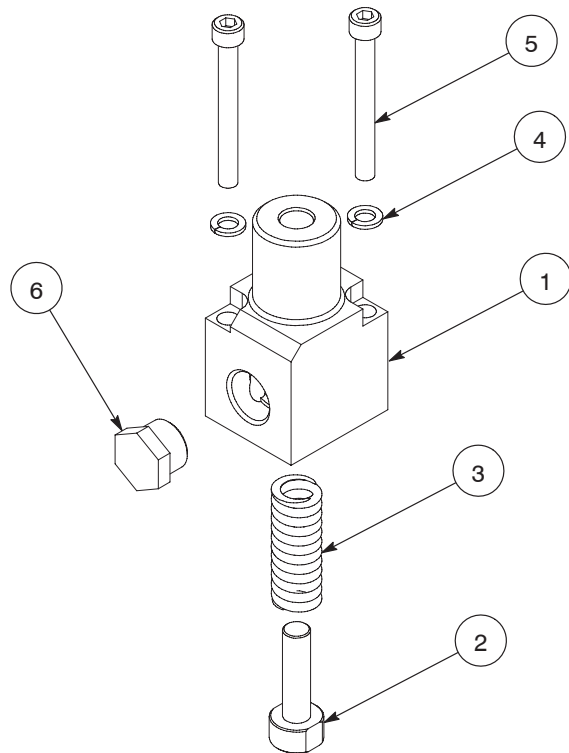

Figure 9-25 OptiStroke air cap parts

421401016

Nozzle-Retaining Clamp (Standard)

See Figure 9-26.

Item	Part	Description	Quantity	Note
—	1048283	Nozzle-retaining clamp assembly, standard module, UM22	—	
1	-----	• Plate, clamp	1	
2	-----	• Clamp, nozzle, 3-way	1	
3	-----	• Screw, clamp, hex, M5	1	
4	-----	• Retaining ring, external, 18, E-ring	1	
5	-----	• Pin, dowel, 0.941 x 0.853 in. long	1	
6	-----	• Pin, dowel, 0.125 x 0.375 in.	2	
7	-----	• Screw, socket, 6-32 x 0.875 in.	2	

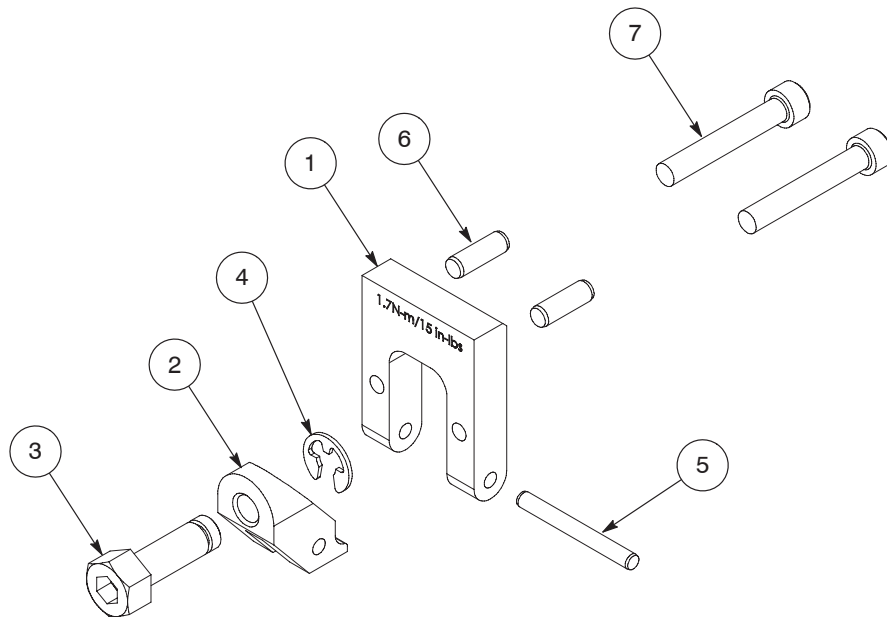

Figure 9-26 Nozzle-retaining clamp parts (standard module)

Nozzle-Retaining Clamp (Right-Angle)

See Figure 9-27.

Item	Part	Description	Quantity	Note
—	1058090	Nozzle-retaining clamp assembly, right-angle module	—	
1	-----	• Plate, clamp	1	
2	-----	• Clamp, nozzle-retaining	1	
3	-----	• Screw, clamp, hex, M5	1	
4	-----	• Retaining ring, external, 18, E-ring	1	
5	-----	• Pin, dowel, 0.0941 x 0.853 in. long	1	
6	-----	• Pin, dowel, 0.125 x 0.375 in.	2	
7	-----	• Screw, socket, 6-32 x 0.625 in.	2	

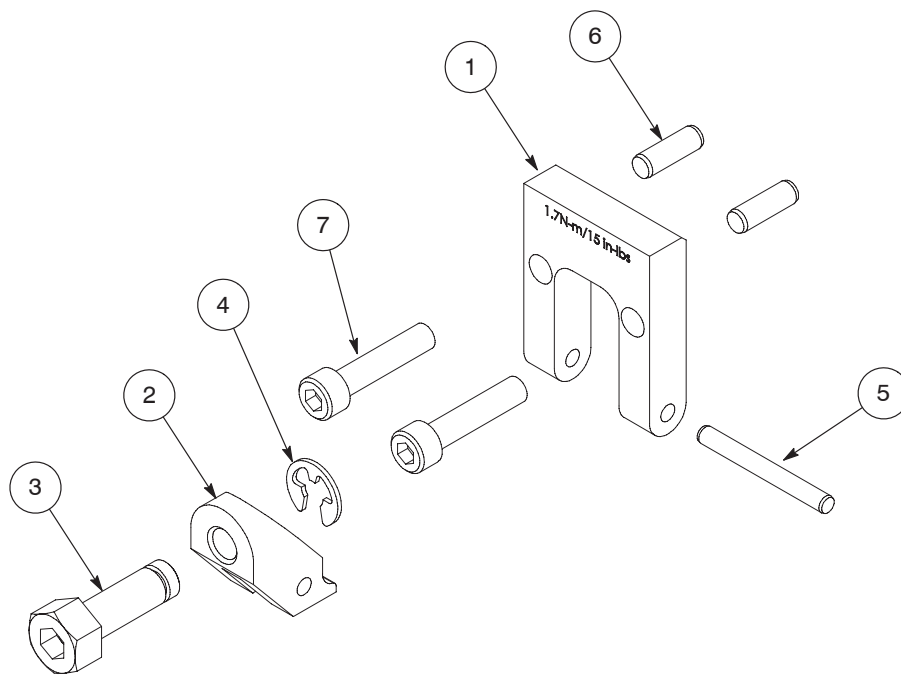

Figure 9-27 Nozzle-retaining clamp parts (right-angle module)

Summit Elastic Guide Parts

If you are installing a Summit applicator for a dedicated strand-coating application, Nordson Corporation strongly recommends installing this elastic guide on the applicator to stabilize the elastic strands as the adhesive is applied to them. Use this parts list and illustration to install the guide.

NOTE: Earlier versions of the Summit applicator, or existing applicators being converted to Summit applicators, may not have provisions for mounting the elastic guide. Contact your Nordson representative for information about making modifications to these applicators to allow mounting of the elastic guide.

Elastic Guide

See Figure 9-28.

Item	Part	Description	Quantity	Note
—	1014665	Elastic guide assembly, without roller	—	
1	1015315	• Plate, slot	1	
2	1015316	• Nut, T, special	1	
3	1015339	• Handle, clamping, ball knob	1	
4	981669	• Screw, socket, 10-32 x 0.500 in.	2	
5	1015312	• Extension arm	1	
6	1015314	• Knob, clamping, fluted, 10-32 x $\frac{3}{8}$ x $\frac{7}{8}$ in.	1	
7	900464	• Adhesive, threadlocking	AR	
8	1015313	• Rod, Z-adjust	1	
9	1015337	• Collar, steel, $\frac{1}{4}$ in. bore, $\frac{11}{16}$ in. OD, $\frac{5}{16}$ in. W	1	
10-11	—	• Item nos. not used	—	
12	981893	• Screw, socket, 10-32 x 0.500 in.	1	
13	-----	Roller	1	A
<p>NOTE A: Refer to the next part of this section, <i>Elastic Guide Rollers</i>. Custom-pitch rollers may be available. Contact your Nordson representative for more information.</p> <p>AR: As Required</p> <p>NS: Not Shown</p>				

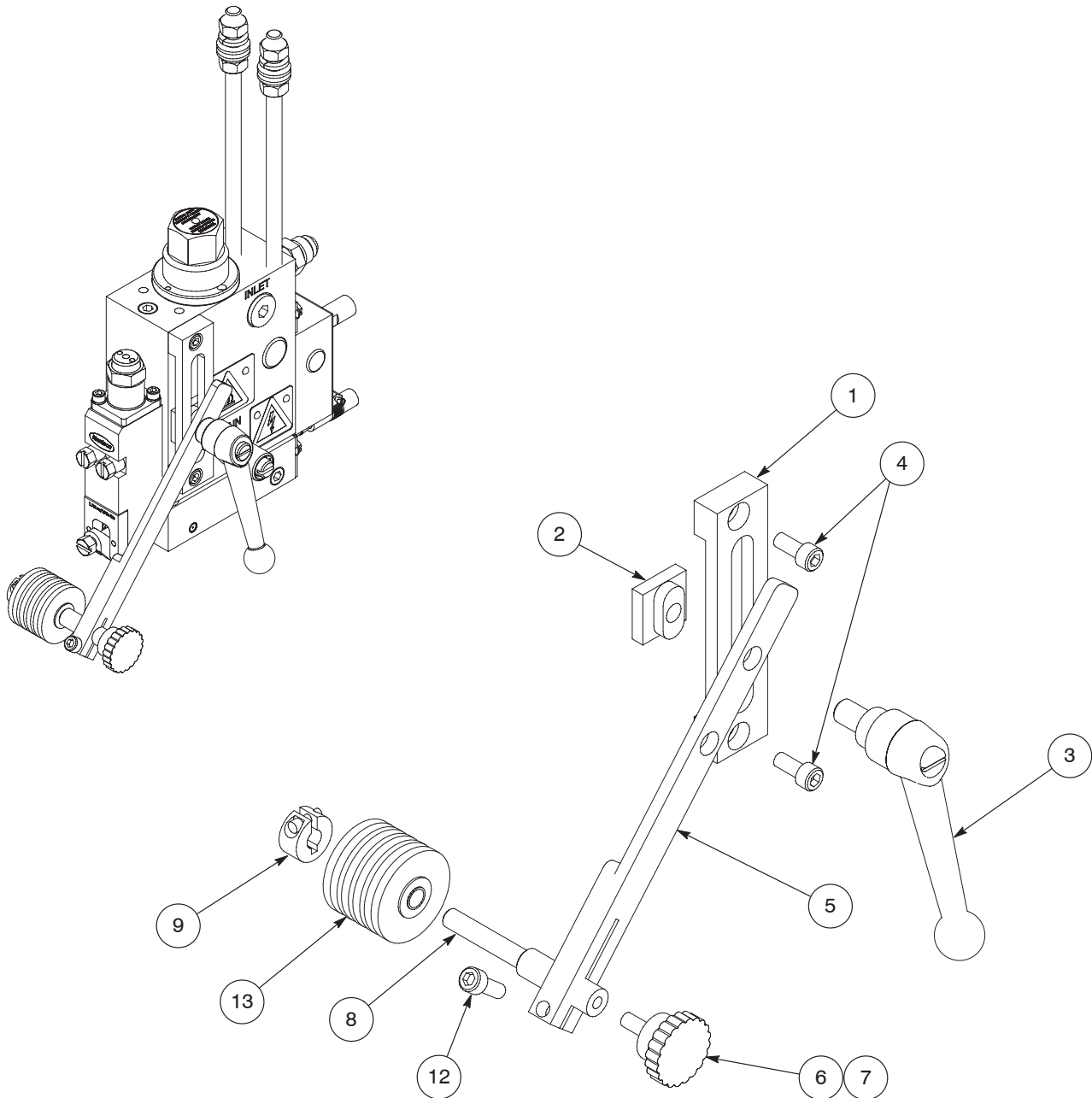

Figure 9-28 Elastic guide parts

Elastic Guide Rollers

See Figure 9-29.

NOTE: Custom-pitch rollers may be available. Contact your Nordson representative for more information.

Number of Openings in Nozzle	Distance Between Openings	Roller Part Number
2	3 mm	1015317
	4 mm	1015330
	5 mm	1015332
3	3 mm	1015318
	4 mm	1015331
	5 mm	1015333
4	3 mm	1015319
	4 mm	1014668
	5 mm	1014948

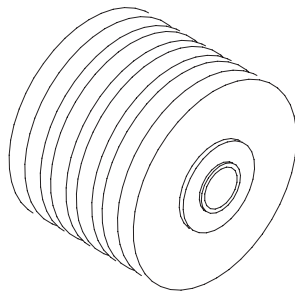

421101004

Figure 9-29 Elastic guide roller

Nozzle Adapter Part Numbers

See Figure 9-30. For some nozzles, including bead nozzles and CF disk and unibody nozzles, an adapter must be installed on the module. The following table provides the part numbers for available adapters.

NOTE: No adapter is required for Universal CF, meltblown, Summit, or SureWrap nozzles.

Item	Part	Description	Quantity	Note
1	1020732	Adapter, bead (for Saturn nozzles)	—	A
2	1019706	• O-ring, Viton, 0.146 ID x 0.031 W in.	1	
3	1050406	Adapter, CF, UM22 (for CF disk and unibody nozzles)	—	
4	1019706	• O-ring, Viton, 0.146 ID x 0.031 W in.	1	

NOTE A: This adapter is used in non-spray applications, which are not covered by this manual. For more information on the use of this adapter, contact your Nordson representative.

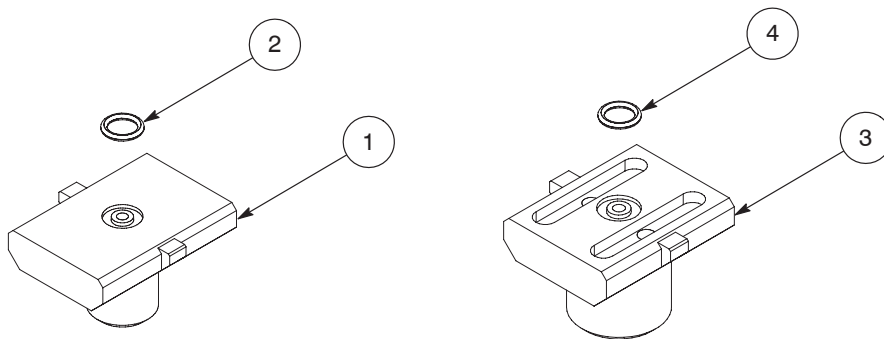

421401023

Figure 9-30 Nozzle adapters

Nozzle Part Numbers

Normally, the choice of nozzle for your applicator will have already been made by you and your Nordson representative. Refer to your sales order to determine what nozzle choices were made. The part numbers for the most commonly used nozzles are provided here.

NOTE: Some nozzles require the use of an adapter. Refer to *Nozzle Adapter Part Numbers* earlier in this manual for adapter part numbers.

CF Disk and Unibody Nozzles

The difference between CF disk and unibody nozzles is explained in Table 9-3. The nozzles may have either 6 air openings or 12 air openings. Nozzles with 12 air openings are referred to as high-frequency nozzles.

To use a CF disk or unibody nozzle with a Universal module, an adapter is required. Refer to *Nozzle Adapter Part Numbers* earlier in this manual for the CF adapter part number.

Table 9-3 CF Disk and Unibody Nozzles

CF Nozzle Type	Description
Disk	The nozzle disk and the nozzle-retaining nut are two separate parts. The disk is held onto the module by the nozzle-retaining nut and is protected from damage because it is recessed inside the nut.
Unibody or steel unibody	The nozzle disk and the nozzle-retaining nut are a single assembly. This design makes the nozzles easier to clean because there are no recessed surfaces (as on disk nozzles). However, the nozzle disks may be more susceptible to damage. The nozzle-retaining nuts on unibody nozzles are color-coded for ease of identification. Steel unibody nozzles are also available.

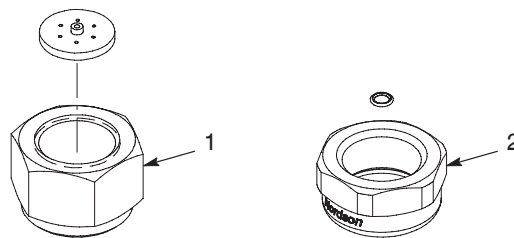

Figure 9-31 CF disk and unibody nozzles

1. CF disk nozzle (disk exploded)

2. CF unibody nozzle (O-ring exploded)

Table 9-4 CF Disk Nozzles (6 Air Openings)

Orifice Diameter	Pattern Width	Part Number
0.012 in.	Standard	860548
0.014 in.	Standard	860574
0.016 in.	Standard	860575
0.018 in.	Standard	860228
0.018 in.	Wide	1047073
0.018 in.	Wide	1047060
0.020 in.	Standard	860435
0.025 in.	Standard	100728
0.030 in.	Standard	810381
0.030 in.	Wide	1047075
0.050 in.	Standard	810300

NOTE: Use nozzle-retaining nut part 119202 with these nozzles.

Table 9-5 High-Frequency CF Disk Nozzle (12 Air Openings)

Orifice Diameter	Pattern Width	Nozzle Part Number
0.018 in.	Standard	755316

NOTE: Use nozzle-retaining nut part 119202 with these nozzles.

Table 9-6 CF Unibody Nozzles (6 Air Openings)

Orifice Diameter	Pattern Width	Nozzle Part Number
0.012 in.	Standard	152168
0.012 in.	Wide	1046126
0.014 in.	Standard	152169
0.016 in.	Standard	152170
0.018 in.	Standard	152171
0.018 in.	Wide	1046150
0.020 in.	Standard	152172
0.020 in.	Wide	1046151
0.025 in.	Standard	156698
0.025 in.	Wide	1046152
0.030 in.	Standard	152173
0.030 in.	Wide	1046156
0.040 in.	Standard	162500

NOTE: All nozzles include O-ring part 940031.

CF Disk and Unibody Nozzles (contd)

Table 9-7 High Frequency CF Unibody Nozzles (12 Air Openings)

Orifice Diameter	Pattern Width	Nozzle Part Number
0.012 in.	Standard	755957
0.012 in.	Narrow	757537
0.014 in.	Standard	756306
0.016 in.	Standard	756307
0.018 in.	Standard	755530
0.018 in.	Wide	1046128
0.020 in.	Standard	756308
0.025 in.	Standard	756309
0.030 in.	Standard	756115
0.030 in.	Wide	1046154
0.046 in.	Standard	757399
0.046 in.	Wide	757469

NOTE: All nozzles include O-ring part 940031.

Table 9-8 CF Steel Unibody Nozzles (6 Air Openings)

Orifice Diameter	Pattern Width	Nozzle Part Number	Color
0.012 in.	Standard	753488	Brown
0.014 in.	Standard	753489	Grey
0.016 in.	Standard	753491	Green
0.018 in.	Standard	753492	Blue
0.020 in.	Standard	753493	Red
0.025 in.	Standard	753494	Pink
0.030 in.	Standard	753495	Black
0.018 in.	Wide	1046158	Yellow
0.030 in.	Wide	1046160	Purple
0.040 in.	Standard	753496	Maroon

NOTE: All nozzles include O-ring part 940031.

Universal CF Nozzles

Universal CF nozzles are one-piece, high-frequency CF nozzles with 12 air openings. No adapter is required to use a Universal CF nozzle on a UM22 module.

Table 9-9 Universal CF Nozzles

Orifice Diameter	Pattern Width	Nozzle Part Number
0.012 in.	Standard	1053960
0.012 in.	Wide	1053964
0.016 in.	Standard	1053961
0.016 in.	Wide	1053966
0.018 in.	Standard	1054730
0.018 in.	Wide	1054731
0.020 in.	Standard	1049565
0.020 in.	Wide	1052500
0.020 in.	14 mm	1053969
0.025 in.	Standard	1053962
0.025 in.	Wide	1053967
0.030 in.	Standard	1053963
0.030 in.	Wide	1053968
0.030 in.	18 mm	1053970

NOTE: All nozzles include O-ring part 1019706.

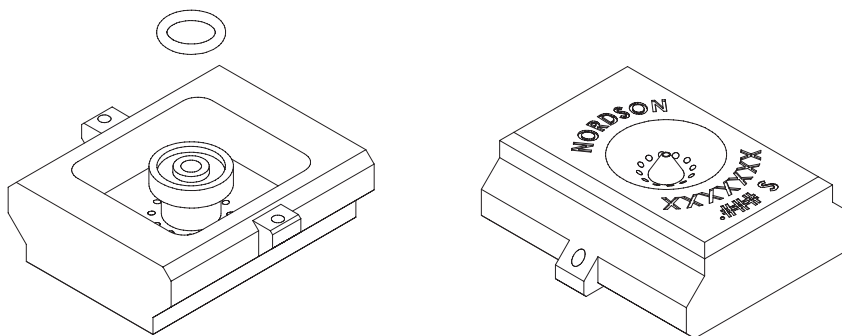

Figure 9-32 Universal CF nozzle

Meltblown Nozzles

Meltblown nozzles may be full coverage or partial coverage nozzles. They may also be high or low-density nozzles (high-density nozzles apply a heavier, denser coating than low-density nozzles).

- See Figure 9-33. A full coverage, high-density nozzle has 20 openings that extend along the entire length of the nozzle. A full-coverage, low-density nozzle has 10 openings that extend along the entire length of the nozzle. The adhesive coating width in either case is 22 mm.
- A partial coverage high- or low-density nozzle has openings through only part of the nozzle, leaving a closed area at either one or both ends. A partial coverage nozzle may be oriented to apply adhesive starting at the left, right, or center of the nozzle. Various nozzle widths are available in either side-oriented or center-oriented configurations. Note that the nozzles are symmetrical, which means that a partial coverage nozzle can be positioned for either right-side or left-side coverage.

No adapter is required to use a meltblown nozzle on a UM22 module.

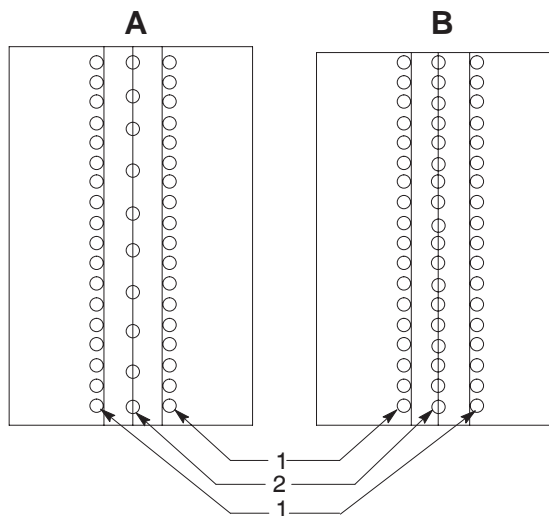

430400004

Figure 9-33 Air and adhesive openings on meltblown full coverage low-density (A) and high-density (B) nozzles

1. Air openings

2. Adhesive openings

Table 9-10 Low-Density Meltblown Laminating Nozzles (22.3 mm)

Coverage	Orientation of Openings	Part Number (Coated Brass)
Not applicable	Air only	1050380
~5–6 mm (1/4 in.) wide	Left/right	1050378
	Centered	1050374
~11 mm (1/2 in.) wide	Left/right	1050376
	Centered	1050373
~15–16 mm (3/4 in.) wide	Left/right	1050375
	Centered	1050372
~22 mm	Full width	1050371
NOTE: All nozzles include O-ring part 1043328.		

Table 9-11 High-Density Meltblown Laminating Nozzles (22.3 mm)

Coverage	Orientation of Openings	Part Number (Coated Brass)
Not applicable	Air only	1050380
~5–6 mm (1/4 in.) wide	Left/right	1050370
	Centered	1050347
~11 mm (1/2 in.) wide	Left/right	1050349
	Centered	1050346
~15–16 mm (3/4 in.) wide	Left/right	1050348
	Centered	1050345
~22 mm	Full width	1050344
NOTE: All nozzles include O-ring part 1043328.		

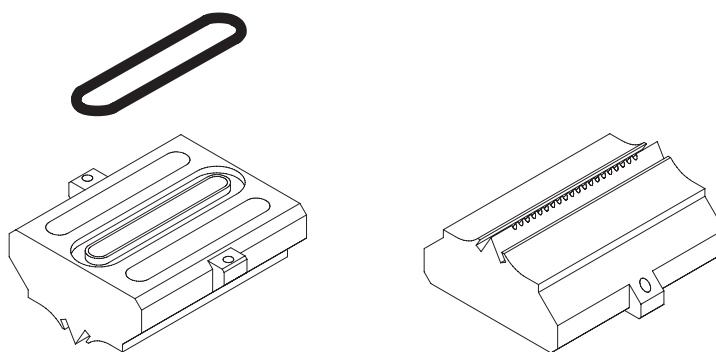

430401002

Figure 9-34 Meltblown nozzle

Summit Nozzles

There are two types of Summit nozzle: elastic coating and laminating.

- An elastic coating nozzle has one adhesive opening for each strand on the product. The spacing of the adhesive openings corresponds to the strands on the product. Elastic coating nozzles may be manufactured to custom strand configurations.
- A laminating nozzle has one to four adhesive openings that are oriented to apply adhesive starting at the left, right, or center of the nozzle. The adhesive coating width ranges from 5–22 mm (0.2–0.9 in.), depending on the number of openings.

No adapter is required to use a Summit nozzle on a UM22 module.

Table 9-12 Summit Laminating Nozzles (22.3 mm)

Coverage	Orientation of Openings	Part Number (Coated Brass)
Not applicable	Air only	1047422
~5–6 mm (1/4 in.) wide	Left/right	1047423
	Centered	1047409
~11 mm (1/2 in.) wide	Left/right	1047424
	Centered	1047420
~15–16 mm (3/4 in.) wide	Left/right	1047425
	Centered	1047421
~22 mm	Full width	1047426

NOTE: All nozzles include O-ring part 1043328.

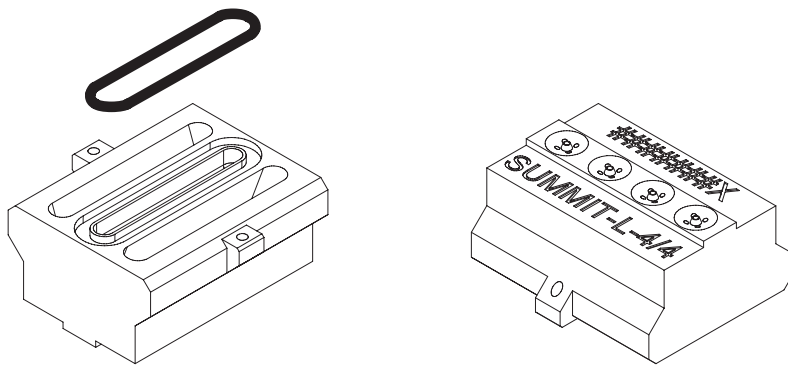

430701007

Figure 9-35 Summit nozzle

SureWrap Nozzles

SureWrap nozzles are available for elastic applications. A SureWrap nozzle has one adhesive opening for each elastic strand on a product. The spacing of the adhesive openings corresponds to the spacing of the elastic strands on the product. SureWrap nozzles may be custom-drilled and the adhesive openings may be biased left or right from center for special applications. All SureWrap nozzles have a hard-release coating to resist wear and facilitate cleaning.

No adapter is required to use a SureWrap nozzle on a UM22 module.

Table 9-13 SureWrap Nozzles for Thin Elastic (22.3 mm)

Number of Streams	Pitch	Part Number (Coated Brass)
1	Not applicable	1049121
2	3	1049122
	4	1049123
	5	1049124
3	3	1049125
	4	1049126
	5	1049127
4	3	1049128
	4	1049129
	5	1049130

NOTE: All nozzles include O-ring part 1043328.

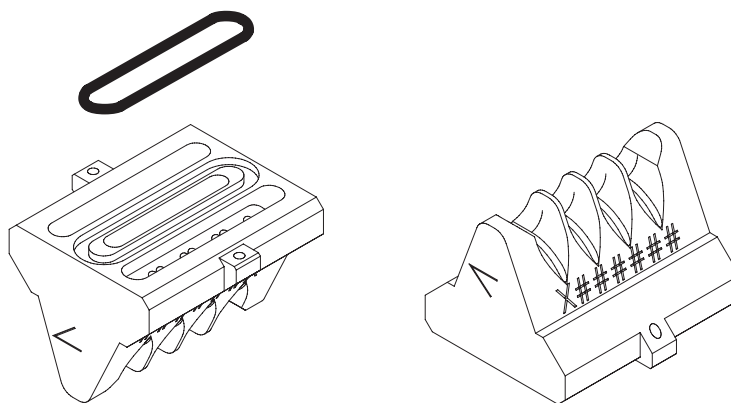

431001002

Figure 9-36 SureWrap nozzle

Signature Nozzles

A Signature nozzle is an assembly of parts that are collectively referred to as a “nozzle.” A parts list for the Signature nozzle assembly is provided on the following page. Signature nozzles are available in full coverage or partial coverage versions. A partial coverage nozzle can be positioned for either right-side or left-side coverage.

No adapter is required to use a Signature nozzle on a UM22 module.

Signature Nozzle Part Numbers

Table 9-14 Signature Nozzles

Coverage	Orientation	Nozzle Part Number
5 mm	1/4 left or right side	1074327
11 mm	1/2 left or right side	1074326
16 mm	3/4 left or right side	1074325
22 mm	Center (full coverage)	1074324

NOTE A: Signature nozzles may be custom-fabricated. Contact your Nordson representative for more information.

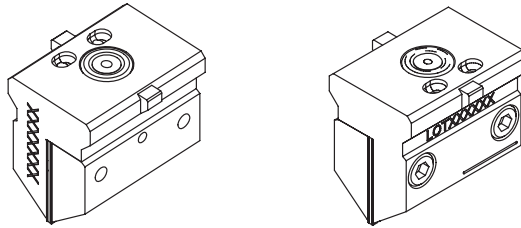

Figure 9-37 Signature nozzle

Signature Nozzle Parts

See Figure 9-38.

Item	Part	Description	Quantity	Note
—	-----	Nozzle, Signature, 22 mm	—	A
1	-----	• Base	1	
2	-----	• Shim, nozzle, air pattern, UM22, 20 hole	2	
3	-----	• Shim, nozzle, UM22, adh/air thru	1	
4	-----	• Shim, nozzle, UM22, adh pattern	1	
5	-----	• Shim, nozzle, UM22, block off	1	
6	-----	• Clamp, signature, nozzle, UM22	1	
7	982775	• Screw, socket, M3 x 12	2	
8	254146	• Quad-ring, 4.47 x 1.78	1	

NOTE A: Refer to Table 9-14 for nozzle part numbers.

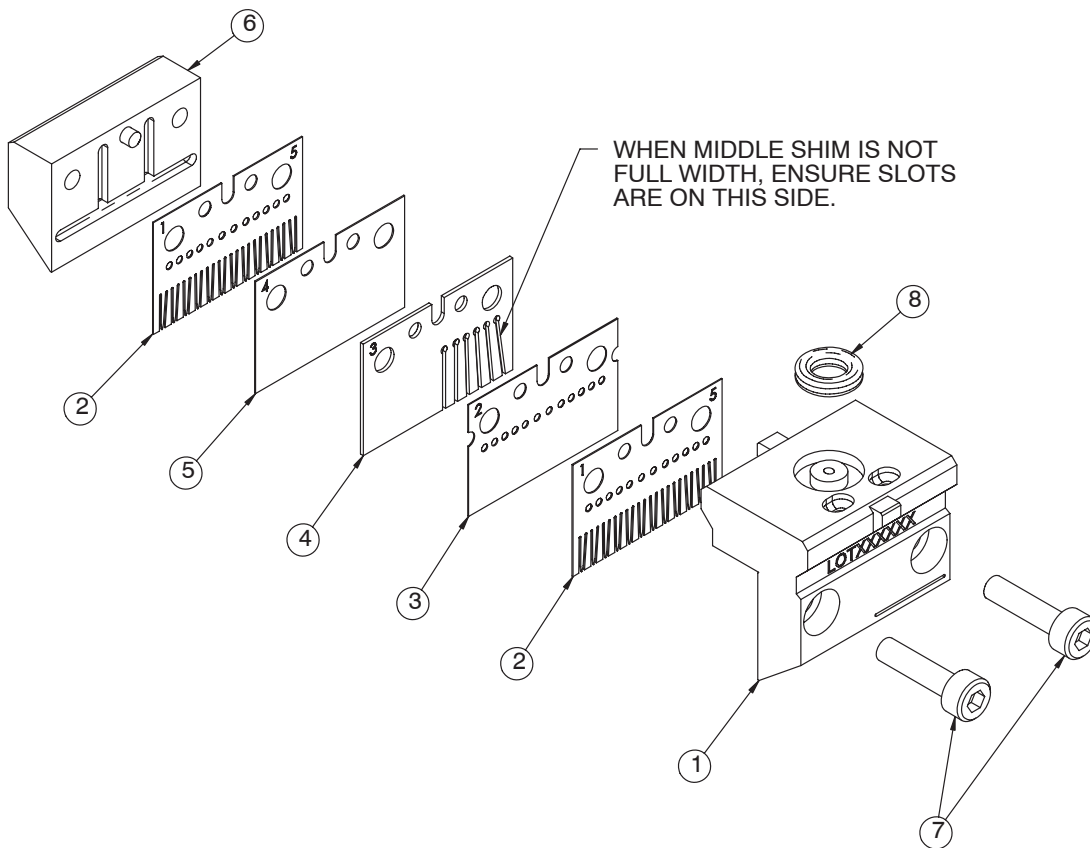

Figure 9-38 Signature nozzle parts

Blank Nozzle

A blank nozzle has no air or adhesive openings. Blank nozzles, in combination with active and partial nozzles, aid in achieving a desired adhesive pattern.

Table 9-15 Blank Nozzle

Part	Description
1045216	Nozzle, blank, Universal, 22 mm
NOTE: Blank nozzles use O-ring part 1019706.	

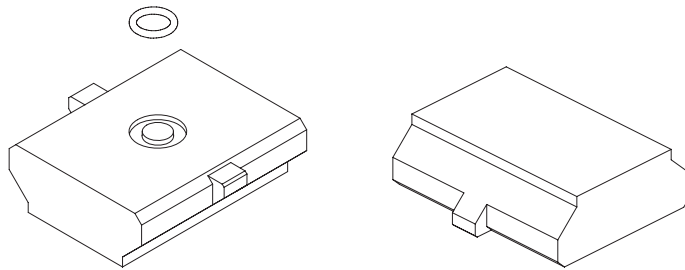

Figure 9-39 Blank nozzle

Module Service Kits

See Figure 9-40.

Item	Part	Description	Quantity	Note
—	1049909	Kit, rebuild, minor, UM22/UM25/UM50 module	—	
1	-----	• Assembly, cartridge, insert, seal	1	
2	-----	• O-ring, Viton, 0.301 ID x 0.070 W in.	3	
—	1049908	Kit, rebuild, major, UM22/UM25/UM50 module	—	
1	-----	• Assembly, cartridge, insert, seal	1	
2	-----	• O-ring, Viton, 0.301 ID x 0.070 W in.	3	
3	-----	• Needle with piston	1	
4	-----	• Spring, compression, 1.146 x 0.360 OD x 0.065 in.	1	
—	1050081	Kit, tool, rebuild, UM22/UM25/UM50 module	—	
5	-----	• Tool, piston insertion	1	
6	-----	• Tool, cartridge	1	
7	-----	• Tool, base	1	
8	900290	Oil, neat's foot	AR	
9	900236	Sealant, paste, Teflon	AR	
10	900223	Lubricant, O-ring, Parker, 4 oz	AR	
NS	401448	Grease, special	AR	A
NOTE A: This special grease is used to lubricate the piston on OptiStroke modules only.				
AR: As Required				

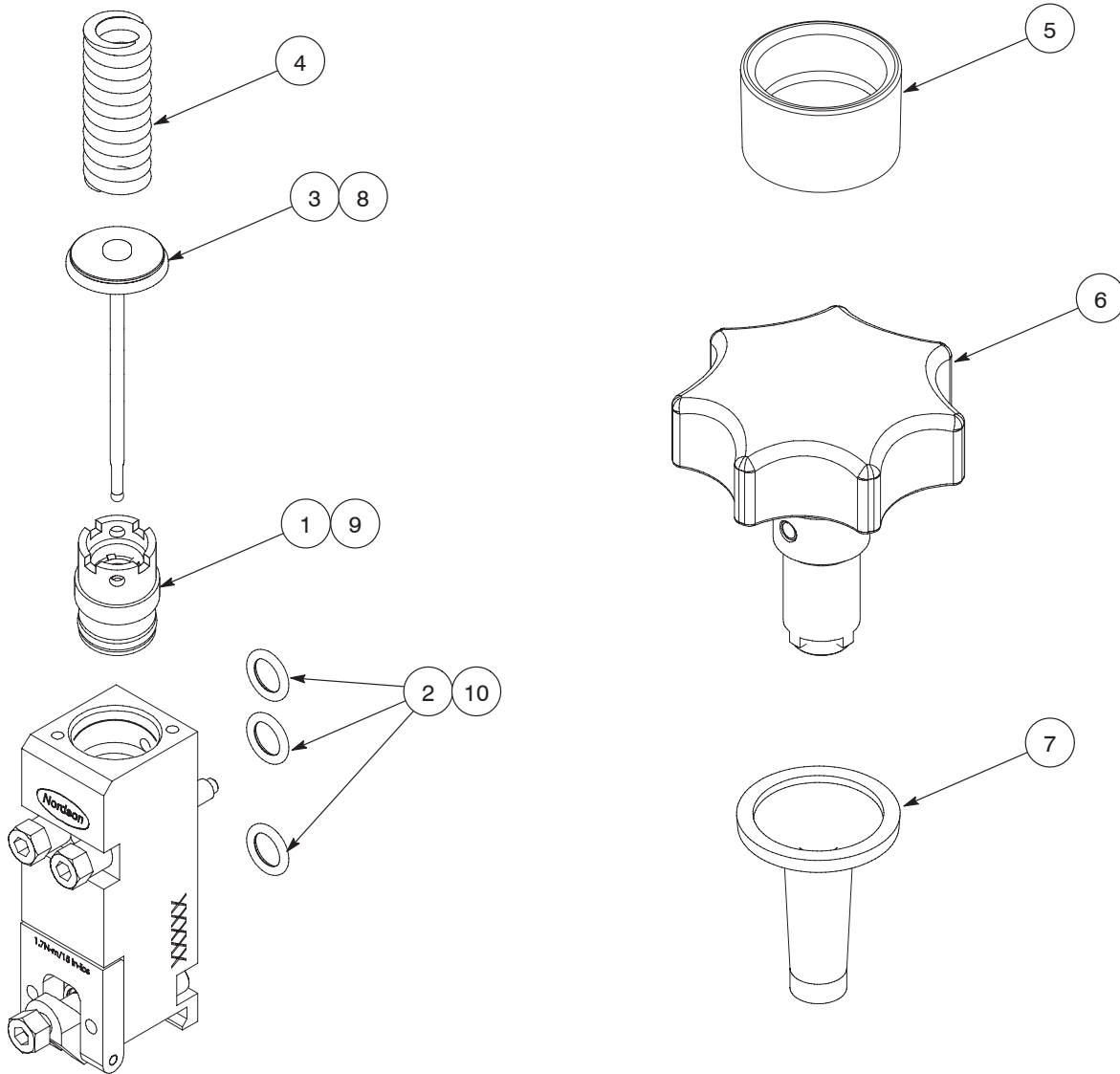

Figure 9-40 Module service kit parts

Recommended Spare Parts and Supplies

For a general spare parts and supplies list, refer to *Recommended Spare Parts and Supplies* in Section 8, *Parts*.

Part	Description	Note
-----	Modules, UM22	A
1048244	• Screw, module mounting, 10-32 (2 required to secure the module to the applicator)	
940111	• O-ring, Viton, 0.301 ID x 0.070 W in. (3 required for the back of the module)	
1069577	Module, cutaway, UM22	B
1049909	Kit, rebuild, minor, UM22/25 (includes cartridge assembly and module O-rings)	
1049908	Kit, rebuild, major, UM22/25 (includes cartridge assembly, module O-rings, needle-and-piston assembly, and compression spring)	
1050081	Kit, tool, rebuild, UM22/25 (includes tools needed to facilitate module rebuilding)	
1059671	Kit, multi-tool, cap/nozzle/filter (for adjusting a module)	
1048249	Air cap assembly, adjustable	
1048704	Air cap assembly, fixed	
1049134	Air cap assembly, OptiStroke	
1048283	Nozzle-retaining clamp assembly, UM22, standard module	
1050456	Nozzle-retaining clamp assembly, UM22, right-angle module	
-----	Nozzles	C
119202	• Nozzle-retaining nut (CF disk nozzles)	
940031	• O-ring, Viton, 0.087 x 0.127 x 0.020 in. (CF unibody nozzles)	
1019706	• O-ring, Viton, 0.146 ID x 0.031 W in. (Universal CF nozzles)	
1043328	• O-ring, Viton, 0.500 OD x 0.580 ID x 0.040 W in. (meltblown, Summit, and SureWrap nozzles)	
1019706	• O-ring, Viton, 0.146 ID x 0.031 W in. (nozzle adapters)	
133665	Kit, CF unibody nozzle O-rings (contains 10 part 940031 O-rings)	
133664	Kit, CF unibody nozzle O-rings (contains 25 part 940031 O-rings)	
133663	Kit, CF unibody nozzle O-rings (contains 100 part 940031 O-rings)	
754766	Wrench, torque, CF disk nozzles	
754767	Wrench, torque, CF unibody nozzles	
901915	Kit, nozzle cleaning, small orifice	
231100	Kit, nozzle cleaning, large orifice	
900223	Lubricant, O-ring, Parker, 4 oz (for O-rings)	
900344	Lubricant, Never-Seez, 8 oz can (for screw threads)	
900290	Oil, neat's foot (for the needle-and-piston assembly)	
900236	Sealant, paste, Teflon (for the cartridge assembly threads)	
401448	Grease, special (for the piston on OptiStroke modules)	
NOTE A: Refer to Table 9-1 for module part numbers.		
B: This cutaway module is nonfunctional and is intended for training purposes.		
C: Refer to <i>Nozzle Part Numbers</i> .		

Technical Data

Applicator Specifications

Table 9-16 provides specifications for an applicator with UM22 modules. Refer to *Applicator-Specific Reference Drawings* in Section 8, *Parts*, for the following information about your applicator:

- applicator dimensions
- cordset style
- number and orientation of filters
- number of modules
- type and number of solenoid valves

Table 9-16 UM22 Applicator Specifications

Item	Specification
Operating temperature	70–204 °C (160–400 °F)
System hydraulic pressure	90 bar (1,300 psi) maximum
Module-actuating air pressure	4.1 bar (60 psi) recommended
Pattern air pressure	CF: 0.3–3.4 bar (5–50 psi); 0.8–1.2 bar (12–18 psi) typical Meltblown: 2.1–3.1 bar (30–45 psi) typical Summit: 0.3–1.7 bar (5–25 psi) typical SureWrap: 0.5–1.5 bar (7–22 psi); 0.8 bar (12 psi) typical
Pattern air temperature	Meltblown: 16–27 °C (30–50 °F) above the adhesive application temperature typical Other applications: 9–15 °C (15–25 °F) above the adhesive application temperature typical
Air consumption	~7.1–56.6 nlm (~0.25–2.0 scfm), depending on the application (higher for meltblown, lower for Summit)
Adhesive viscosity	500–10,000 cps
Adhesive applications supported	CF, meltblown, Summit, and SureWrap
Adhesive pattern capability	Continuous or intermittent
Mounting height	CF: 19–51 mm (0.75–2.0 in.) above substrate typical Meltblown: 19–51 mm (0.75–2.0 in.) above substrate typical Summit: 12–25 mm (0.5–1.0 in.) above substrate typical SureWrap: contact

Torque Specifications

These torque specifications are also stated within the appropriate procedures.

Item	Torque Specification
Air cap screws	1.7 N•m (15 in.-lb)
CF disk nozzles	3.4 N•m (30 in.-lb)
CF unibody nozzles	0.6 N•m (5 in.-lb)
Module mounting screws	3.4 N•m (30 in.-lb)
Nozzle-retaining clamp screw	1.7 N•m (15 in.-lb)

Module Dimensions

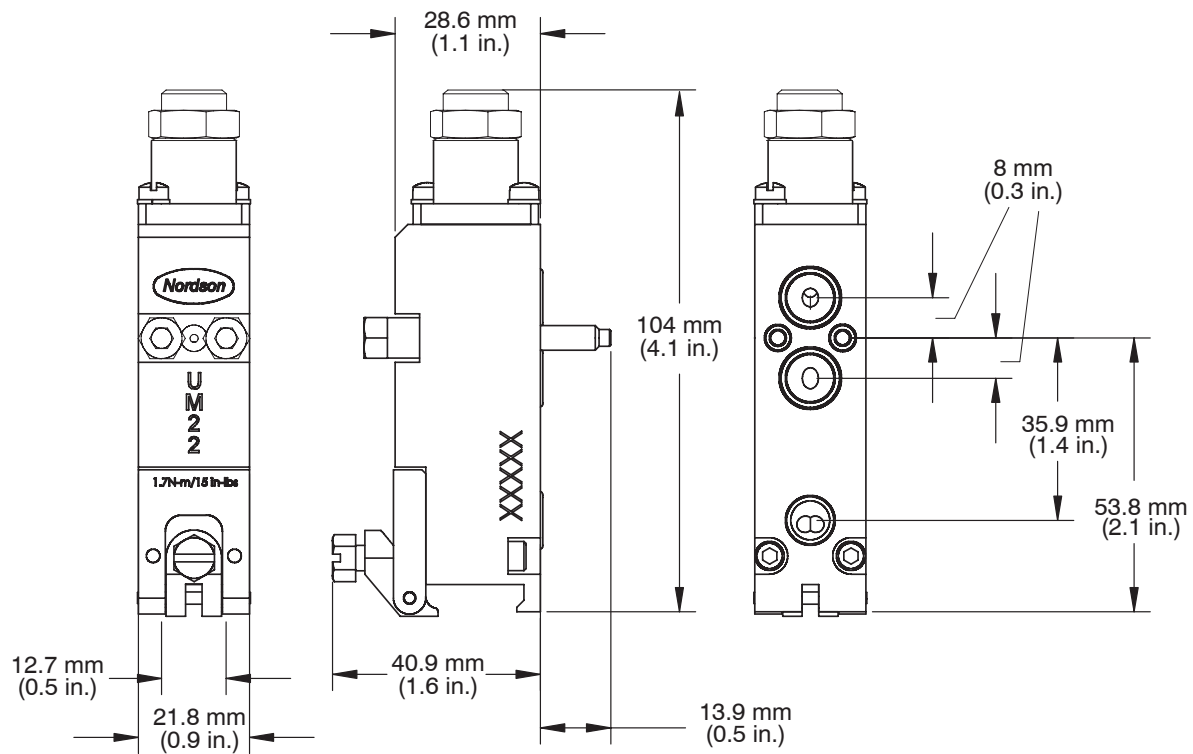

Figure 9-41 Adjustable UM22 module dimensions

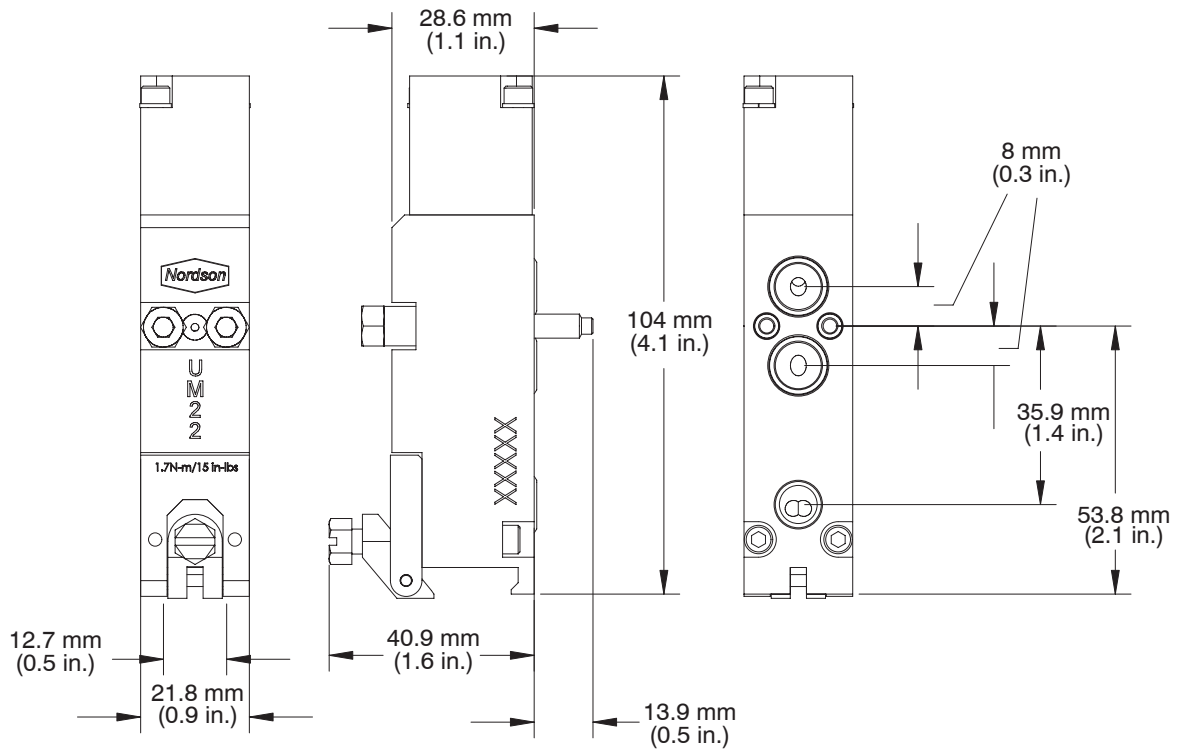

Figure 9-42 Fixed UM22 module dimensions

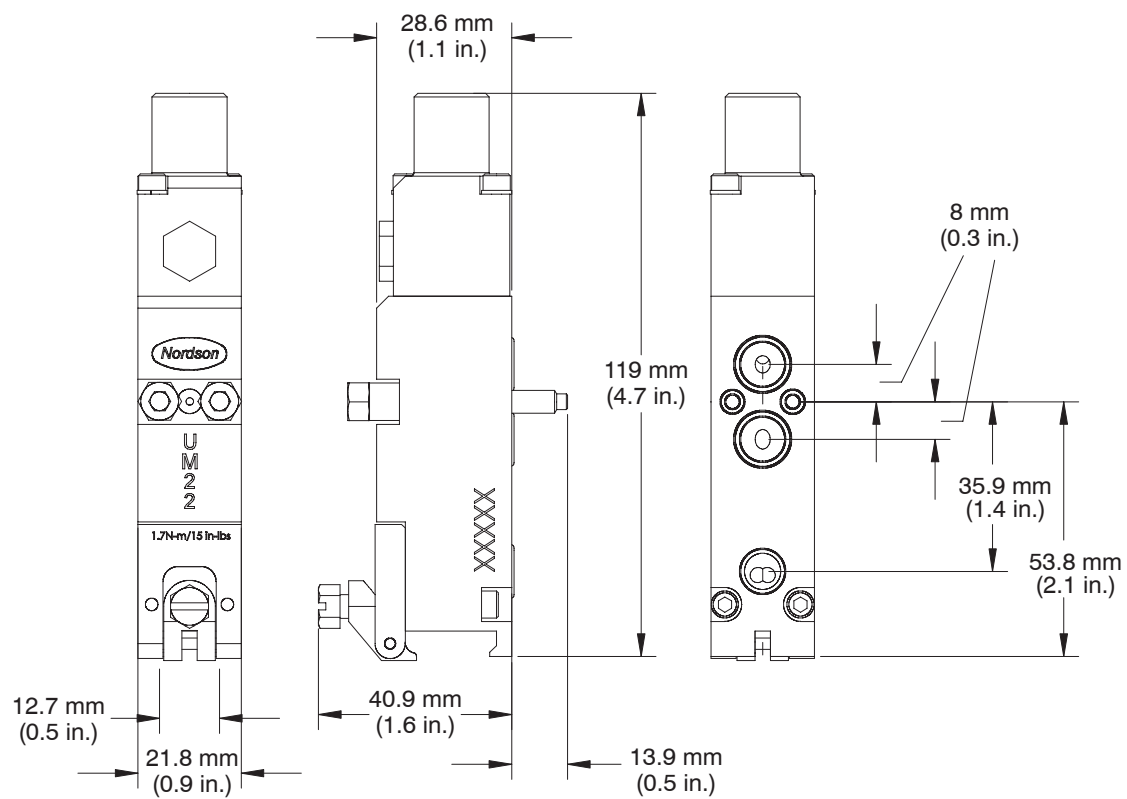
Module Dimensions (contd)

Figure 9-43 OptiStroke UM22 module dimensions

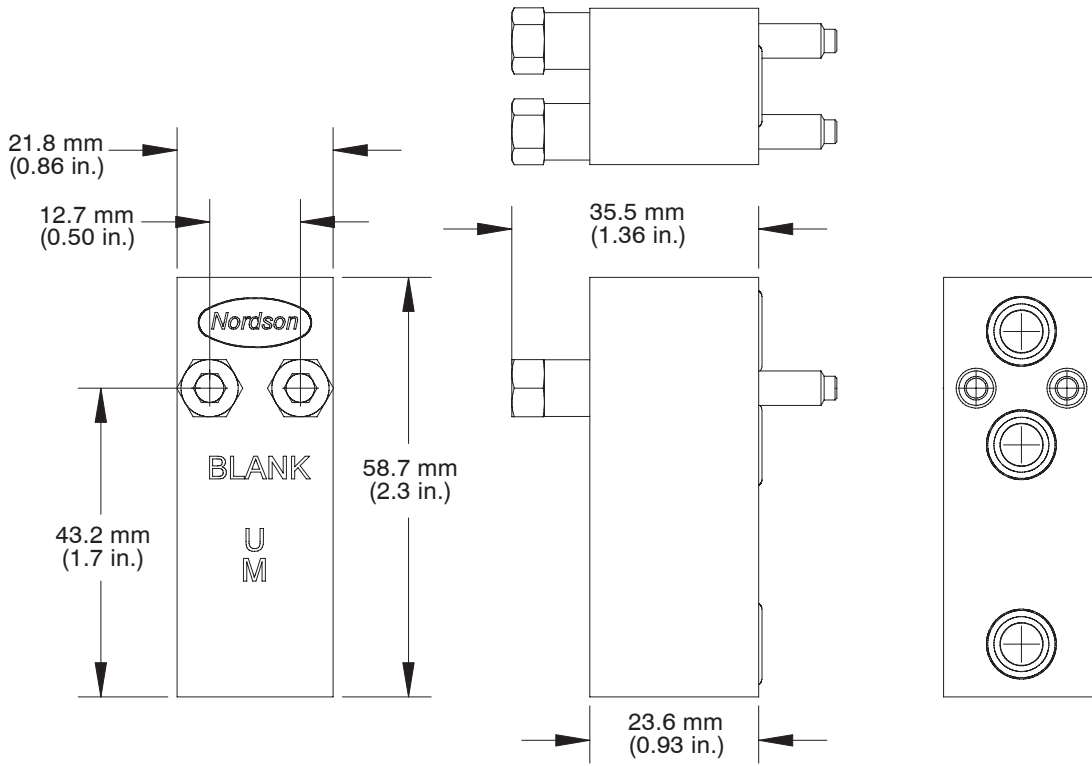

Figure 9-44 Blank UM22 module dimensions