



Nordson Corporation

OPERATOR'S CARD

P/N 1029961C

HMS Applicators (CF200)

Safety



WARNING: Allow only personnel with appropriate training and experience to operate or service the equipment. The use of untrained or inexperienced personnel to operate or service the equipment can result in injury, including death, to themselves and others, and damage to the equipment.



WARNING: Risk of burns. Failure to relieve system pressure before performing maintenance or repairs can cause hot adhesive to spray from a connecting point. Relieve system pressure as instructed in this and all other related documentation.



WARNING: Always wear heat-protective clothing, safety goggles (ANSI Z87.1-1989 or equivalent), and safety gloves when working with hot melt equipment.



WARNING: Obtain and read the Material Safety Data Sheets for all materials used.

Introduction

HMS applicators apply hot melt adhesive to a product. Adhesive enters the inlet port of the applicator and is directed through the heated adhesive manifold into one or more CF200 modules. When the modules are triggered open (via solenoid valves), the adhesive exits the modules through the adhesive passages in the CF nozzles. Simultaneously, pattern air flows through the heated air manifold into the air passages of the CF nozzles, causing the adhesive to form the Controlled Fiberization pattern.

Figure 1 shows a typical applicator. Figure 2 identifies the key parts of the applicator.

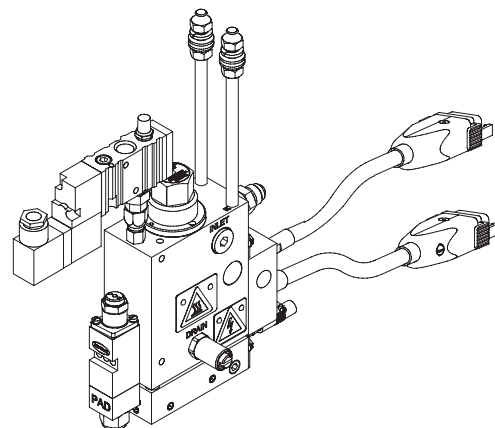
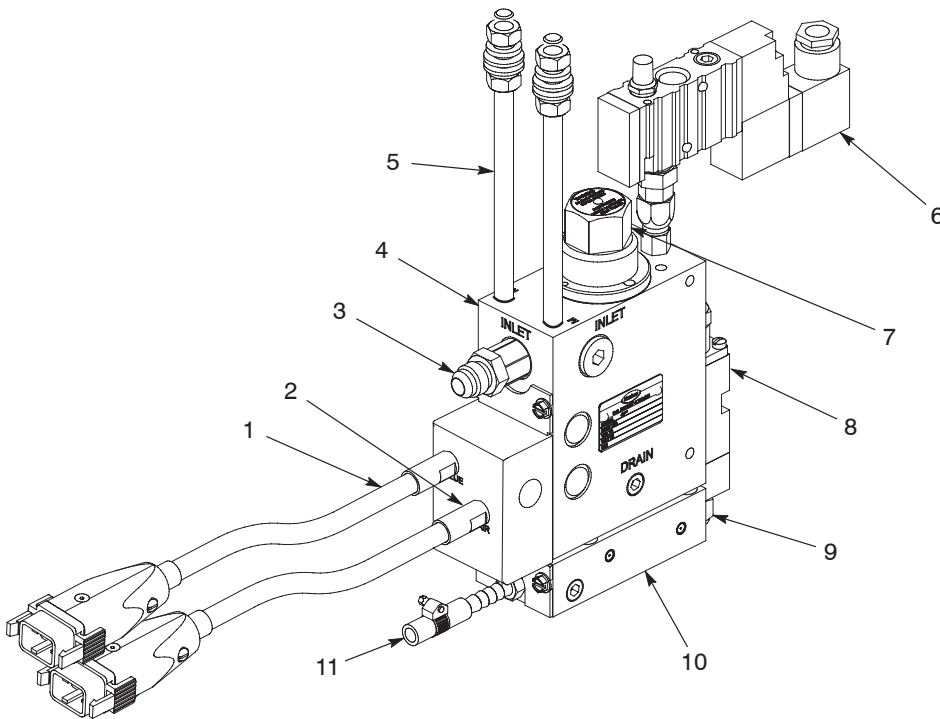

Figure 1 Typical HMS applicator (single-module applicator with a CF200 module)

Key Parts



420400014C

Figure 2 Key parts of an HMS applicator (single-module applicator with a CF200 module shown)

- | | | |
|--------------------------------|-------------------|-----------------------------------|
| 1. Adhesive manifold cordset | 5. Mounting rod | 9. CF nozzle |
| 2. Heated air manifold cordset | 6. Solenoid valve | 10. Heated air manifold |
| 3. Hose connector | 7. Filter | 11. Pattern air supply connection |
| 4. Adhesive manifold | 8. CF200 module | |

Installation

Complete these tasks to install the applicator. For detailed procedures and installation guidelines, refer to the applicator manual.

1. If applicable, install solenoid valve(s) on the applicator. Position the valves as close to the applicator as possible.
2. Mount the applicator on the parent machine. Ensure that there will be enough clearance to service the applicator.
3. Connect the hose(s) to the applicator.
4. Connect a regulated module-actuating air supply to the solenoid valve(s). Use only clean, dry, unlubricated air.
5. Connect a regulated pattern air supply to the pattern air inlet port. Use only clean, dry, unlubricated air.
6. Connect the solenoid valves to a triggering device, such as a timer or pattern controller.
7. Connect the applicator cordsets to a power source (such as the hose or the melter). Use splitter and/or extension cables as needed.
8. Flush the applicator (with nozzles removed) to remove any factory-testing residue.
9. Install the nozzle(s).
10. Test the applicator operation until the desired performance is achieved.

Operation

Starting the Applicator

Starting the applicator involves starting the melter and enabling the air supplies. Refer to the melter manual as needed to operate the melter.

1. Start the melter and heat the system to application temperature.
2. Turn on the pattern air.
3. Turn on the module-actuating air.
4. Start the melter pump(s).
5. Start the production line.

Shutting Down the Applicator

1. Stop the production line.
2. Stop the melter pumps.
3. Shut off the module-actuating air.
4. Shut off the pattern air.
5. Relieve system pressure. Refer to *Relieving System Pressure*.
6. Shut down the melter.

Relieving System Pressure

1. Stop the melter pump(s). Refer to the melter manual as needed.
2. Shut off the module-actuating air.
3. Place drains pans under all melter and applicator drain valves.
4. See Figure 3. Open the melter and applicator drain valves by turning the drain valve screws counterclockwise. Some adhesive will drain from the valves.
5. Manually trigger all modules at the solenoid valves.
6. Close the applicator and melter drain valves.

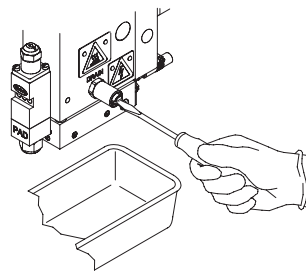

420100030C

Figure 3 Opening an applicator drain valve

Maintenance

Recommended Maintenance Activities and Schedule

Table 1 provides a recommended maintenance schedule. Base how often you perform these maintenance activities on your operating environment.

Table 1 Recommended Maintenance Schedule

Frequency	Activity
Daily	Clean all exterior applicator surfaces.
	Check hose connections for leaks.
Weekly	Clean nozzles. Refer to <i>Cleaning Nozzles</i> .
As needed	Replace the filter screen. Refer to <i>Replacing the Filter Screen</i> .
	Check all electrical connections.
	Clean air pressure regulator filter elements.

Cleaning Nozzles

There are two types of CF nozzle: disk and unibody. On disk nozzles, the nozzle disk and nozzle-retaining nut are two separate parts. On unibody nozzles, the nozzle disk and nozzle-retaining nut are one piece.

Nozzle Removal

1. Heat the system to a temperature that is slightly higher than the application temperature.
2. Relieve system pressure. Refer to *Relieving System Pressure* under *Operation*.
3. Trigger the applicator solenoid valves to relieve any remaining pressure.
4. Shut off the module-actuating air.
5. Decrease the pattern air pressure. Leave just enough pressure to prevent adhesive from entering the pattern air inlet.

Maintenance (contd)

Nozzle Removal (contd)

- See Figure 4. Remove the nozzles using whichever of the following procedures is appropriate:

Nozzle Type	Removal Procedure
Disk nozzle	Use a wrench to loosen the nozzle retaining nut and then remove the nozzle pieces by hand.
Unibody nozzle	Use a wrench to loosen the nozzle and then remove the nozzle by hand.

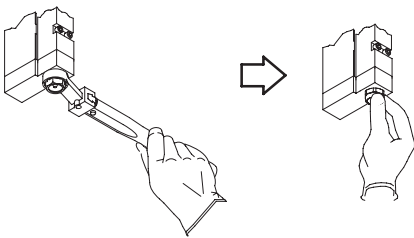

Figure 4 Removing a CF nozzle

430100006C

Nozzle Cleaning

- Clean the nozzles using one of methods shown in Table 2 (next page). Use only cleaning agents recommended by the adhesive supplier.
- If there is any remaining char buildup on the nozzles, gently scrape the char from the nozzles.

CAUTION: Risk of equipment damage. Use of an open torch, drill, or broach can damage a nozzle. Use only a pin-type probe to clean nozzle orifices and do not twist the probe inside the nozzle.

- See Figure 5. If cleaning of the adhesive nozzle orifices is necessary, use a pin-type probe that is one size smaller than the orifice size: insert the probe in the direction opposite the adhesive flow and then remove the probe without twisting it.

NOTE: Nordson offers two nozzle cleaning kits that contain a holder and several probe sizes. Refer to *Recommended Spare Parts and Supplies*.

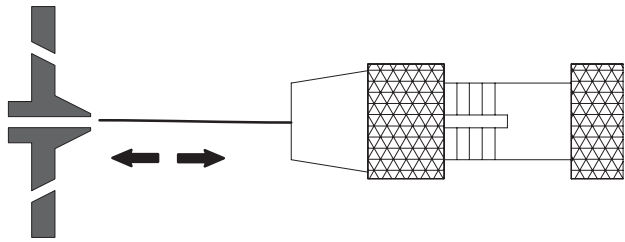

Figure 5 Correct direction to insert a pin-type probe into a nozzle (CF nozzle disk shown)

Nozzle Installation

Install the nozzles using whichever of the following procedures is appropriate:

Nozzle Type	Installation Procedure
Disk nozzle	Orient the nozzle disk as shown in Figure 6 and place the disk inside the nozzle-retaining nut; then thread the nut onto the module. Use a wrench to tighten the nut to no more than 3.4 N•m (30 in.-lb).
Unibody nozzle	Thread the nozzle onto the module. Use a wrench to tighten the nozzle to 0.6 N•m (5 in.-lb).

NOTE: Nordson offers a torque wrench for each type of CF nozzle. Refer to *Recommended Spare Parts and Supplies*.

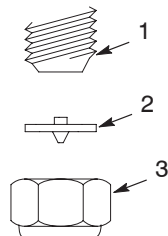

430100001C





Figure 6 Correct assembly of a CF disk nozzle

- Module threads
- Nozzle disk
- Nozzle-retaining nut

Note: The conical nozzle tip must point away from the module threads.

Maintenance (contd)

Table 2 Nozzle Cleaning Methods

Cleaning Method	Procedure
<p>Citrus-based solution and ultrasonic tank</p> <p>NOTE: This is the most thorough method.</p>	<ol style="list-style-type: none"> Place the nozzles in citrus-based solvent/degreasing solution and soak them overnight or for approximately 4 hours. This dissolves and loosens the adhesive and char buildup. Remove the nozzles from the citrus-based solvent/degreasing solution and place them in an alkaline solution heated to the appropriate temperature (refer to the MSDS) in an ultrasonic tank. Soak the nozzles for approximately 10 minutes. This will remove adhesive and char from the orifices. Scrub the nozzles with a soft, non-metallic brush to remove debris. Gently blow air through the nozzle orifices from the mounting side of the nozzle.
<p>Nordson Type-R fluid</p>	<ol style="list-style-type: none"> Place the nozzles in a controlled heating device containing Nordson Type-R fluid and heat it above the melting point of the adhesive (refer to the MSDS). Scrub the nozzles with a soft, non-metallic brush to remove debris.
<p>Electric heat gun</p>	<ol style="list-style-type: none"> Heat the nozzles with a flameless electric heat gun. Scrub the nozzles with a soft, non-metallic brush to remove debris.
<p>Ultrasonic tank</p>	<ol style="list-style-type: none"> Place the nozzles in an alkaline solution heated to the appropriate temperature (refer to the MSDS) in an ultrasonic tank. Soak the nozzles for approximately 10 minutes. Scrub the nozzles with a soft, non-metallic brush to remove debris. Gently blow air through the nozzle orifices from the mounting side of the nozzle.
<p>Oven</p> <p>NOTE: This method will cause discoloration of unplated brass nozzles. This discoloration is cosmetic only and will not adversely affect nozzle performance.</p> <p>NOTE: This method is not recommended for color-coded nozzles (such as Saturn and CF steel unibody nozzles) because it will remove the color from the nozzles.</p>	<div style="display: flex; align-items: flex-start;"> <div style="margin-right: 10px;">  </div> <div> <p>WARNING: Risk of explosion, fire, or toxic vapor release. Depending on the type of adhesive and/or organic solvent used with the nozzles, heating them in an oven can cause a hazardous event. Before using an oven to clean nozzles, consult with the oven manufacturer about the viability of this method and the safety risks. Follow the manufacturer's recommendations.</p> </div> </div> <div style="display: flex; align-items: flex-start; margin-top: 10px;"> <div style="margin-right: 10px;">  </div> <div> <p>WARNING: Use the oven heating controls to keep the oven at the desired temperature. Do not use an oven that does not have heating controls.</p> </div> </div> <div style="display: flex; align-items: flex-start; margin-top: 10px;"> <div style="margin-right: 10px;">  </div> <div> <p>WARNING: The heating temperature and time may need to be adjusted based on the oven type, the adhesive type, and the amount of char buildup on the nozzles. Nordson Corporation recommends testing this procedure on discarded nozzles prior to using it on good nozzles.</p> </div> </div> <p>CAUTION: Risk of equipment damage. Remove O-rings before cleaning nozzles in an oven. Failure to do so can cause a chemical reaction that will permanently damage the nozzles.</p> <ol style="list-style-type: none"> Ensuring that O-rings have been removed from the nozzles, place them in an electric oven heated to approximately 385 °C (725 °F). Allow the nozzles to bake for approximately 3–4 hours. Turn off the oven and allow the nozzles to cool; then remove the nozzles. <div style="display: flex; align-items: flex-start; margin-top: 10px;"> <div style="margin-right: 10px;">  </div> <div> <p>WARNING: Risk of fire. Use a heat-proof cloth to clean nozzles. Even cotton can burn in high-temperature conditions.</p> </div> </div> <div style="display: flex; align-items: flex-start; margin-top: 10px;"> <div style="margin-right: 10px;">  </div> <div> <p>WARNING: Risk of equipment damage. Handle nozzles carefully to avoid denting the orifices, which can degrade the adhesive pattern.</p> </div> </div> <ol style="list-style-type: none"> Wipe the nozzles with a soft cloth and then gently blow air through the nozzle orifices from the mounting side of the nozzle.

Maintenance *(contd)*

Replacing the Filter Screen

Replace the filter screen when the adhesive flow diminishes or when pressure builds up in the system. For most applications, the filter screen should be replaced monthly.

NOTE: If your applicator has a non-standard filter, refer to the filter screen replacement procedure in the applicator manual.

Filter Removal

1. Heat the system to application temperature.
2. Relieve system pressure. Refer to *Relieving System Pressure under Operation*.
3. Trigger the applicator solenoid valves to relieve any remaining pressure.
4. Shut off the module-actuating air.
5. Decrease the pattern air pressure. Leave just enough pressure to prevent adhesive from entering the pattern air inlet.
6. See Figure 7. Use a socket wrench to loosen the filter assembly and then remove the assembly by hand over a drain pan.

NOTE: The filter may be installed in the right side, left side, or top of the applicator.

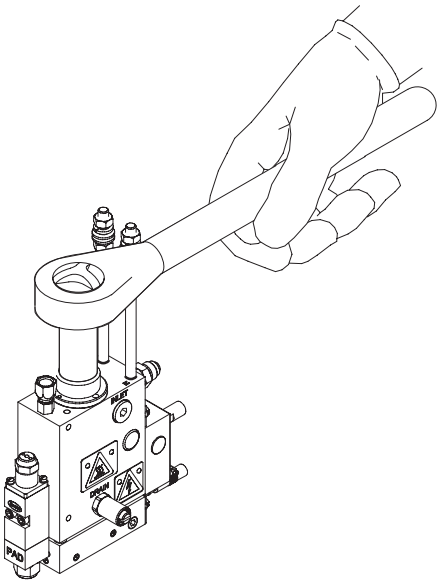
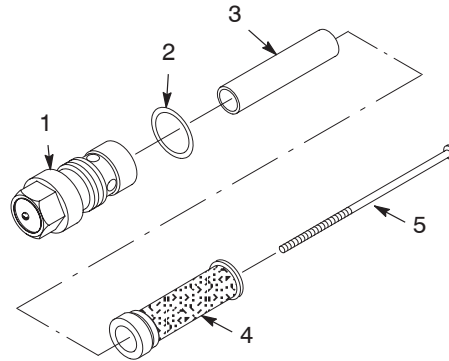

Figure 7 Removing a filter (vertical filter shown)

Filter Screen Replacement

1. See Figure 8. Disassemble the filter and discard the screen.
2. Inspect the O-ring for cuts, hardening, or other damage and replace as necessary.
3. Apply O-ring lubricant to the O-ring and assemble the filter with a new screen.



690100004C

Figure 8 Filter components

- | | |
|-----------|-----------|
| 1. Bung | 4. Screen |
| 2. O-ring | 5. Screw |
| 3. Tube | |

Filter Installation

1. Ensure that the system is at application temperature.
2. Apply anti-seize lubricant to the filter screw threads, insert the filter in the manifold, and turn it clockwise by hand until it seats.
3. Remove the nozzles from the applicator and pump adhesive through applicator. This removes any loose char remaining in the applicator or modules.
4. Reinstall the nozzles and resume normal operation.

Recommended Spare Parts and Supplies

Applicator Spare Parts

See Figure 9. For complete parts lists, refer to the applicator manual.

Item	Part	Description	Quantity	Note
1	-----	Solenoid valve	AR	A
2	147883	Filter, in-out, 0.006 in.	AR	B
NS	147884	• Screen, filter, 0.006 in. mesh	1	B
NS	941201	• O-ring, Viton, 1.000 x 1.188 x 0.094 in.	1	B
3-4	-----	Cordsets (adhesive and air)	AR	A
5	144906	Module, CF200 PAD	AR	
6	940111	• O-ring, Viton, 0.301 ID x 0.070 W in.	3	
7	981171	• Screw, socket, 10-32 x 1.250 in.	2	
8	-----	Nozzle	AR	A
NS	940031	• O-ring, Viton, 0.087 x 0.127 x 0.020 in. (for disk and unibody nozzles)	1	C
NS	119202	• Nozzle-retaining nut (for disk nozzles)	1	

NOTE A: Refer to the applicator manual for part numbers.
 B: If your applicator has a non-standard filter, refer to the applicator manual for part numbers.
 C: The following value packs of this O-ring are available: 133665 (contains 10 O-rings), 133664 (contains 25 O-rings), and 133663 (contains 100 O-rings).

AR: As Required
 NS: Not Shown

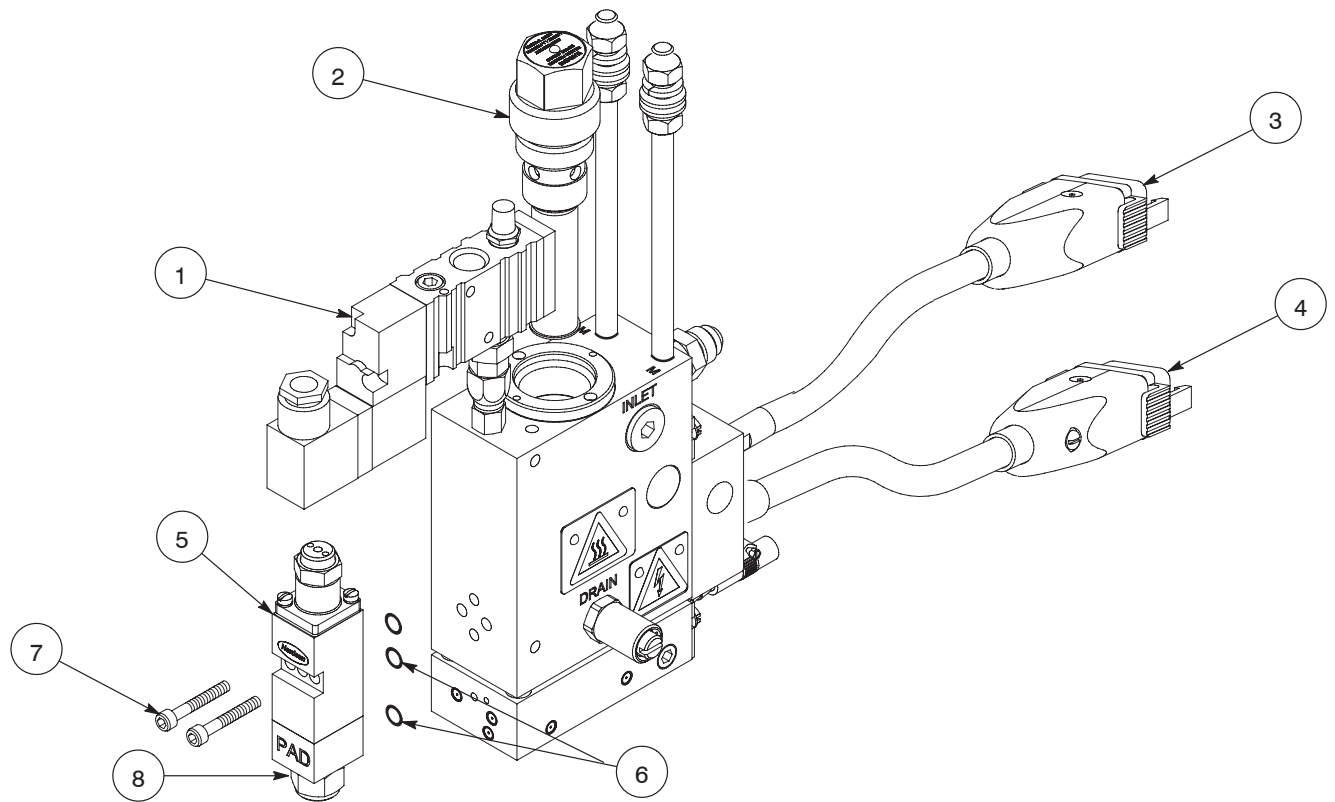

Figure 9 Applicator spare parts

Recommended Spare Parts and Supplies *(contd)*

Service Kits and Supplies

For complete parts lists, refer to the applicator manual.

Part	Description	Note
272818	Kit, module rebuild, one module, with needle-and-piston assembly (rebuilds one module)	
142753	Kit, module rebuild, ten modules, with needle-and-piston assembly (rebuilds ten modules)	
161414	Kit, module rebuild, ten modules, without needle-and-piston assembly (rebuilds ten modules)	
272822	Kit, needle-and-piston assembly and seals	
147473	Kit, compression springs and seal support discs	
272290	Kit, needle-and-piston assembly	
901915	Kit, nozzle cleaning, small orifice	
231100	Kit, nozzle cleaning, large orifice	
754766	Wrench, torque, CF disk nozzles	
754767	Wrench, torque, CF unibody nozzles	
1059671	Kit, multi-tool, cap/nozzle/filter (for adjusting a module)	
900223	Lubricant, O-ring, Parker, 4 oz (for O-rings)	
900344	Lubricant, Never Seez, 8 oz can (for screw threads)	
900290	Oil, neat's foot (for the needle-and-piston assembly)	

Issued 9/05

Original copyright date 2002. CF, Nordson, and the Nordson logo are registered trademarks of Nordson Corporation.

Controlled Fiberization is a trademark of Nordson Corporation.

Never Seez is a registered trademark of Bostik Inc.

Parker Lubricant is a registered trademark of Parker Seal.

Viton is a registered trademark of DuPont Dow Elastomers. L.L.C.