







Module Rebuild Kit

Follow the instructions provided to rebuild Classic Blue, Solid Blue and Sure Bead modules.

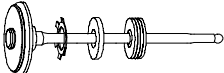
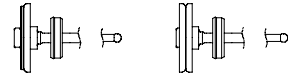
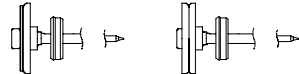
WARNING: Risk of personal injury or equipment damage! Refer to the safety information provided in the gun manual before servicing the module. Failure to comply with the safety information provided can result in personal injury, including death.

Required Tools:

Flat-head screw driver
4 mm hex wrench
O-ring lubricant, P/N 900223
Never-Seez, P/N 900341

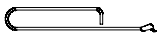
-  Needle with hat seals (4), seal retainer and retaining ring (ClassicBlue)
 -  Needle with spring seal (SolidBlue AOAC and AOAC)
 -  Needle with spring seal (SureBead AOAC and AOAC)
 -  O-ring, module to manifold (qty 2 for AOAC, qty 3 for AOAC)
 -  Compression spring (qty. 1)
 -  Spring seal (qty. 1)
 -  Seal retainer (qty. 1)
 -  Nozzle seat O-ring (qty. 1)
 -  Retaining ring removal tool (qty. 1)
- Installation tools (shown on next page)

Disassemble the Module

1. Heat the system to operating temperature. Shut the system down. Disconnect and lock out power.

2. Remove the module from the manifold.

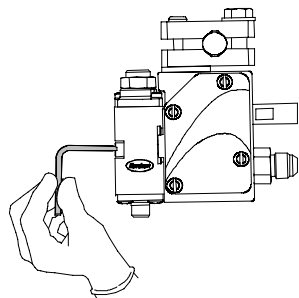

3. Disassemble the module. Use the retaining ring removal tool to remove the retaining ring inside the module. Discard the shaded items.

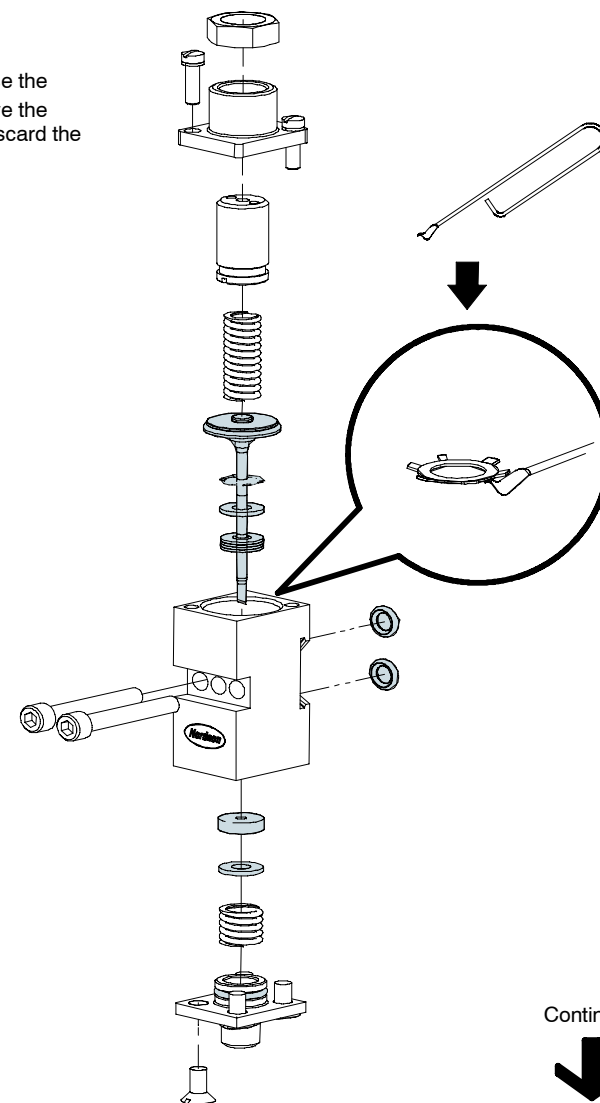
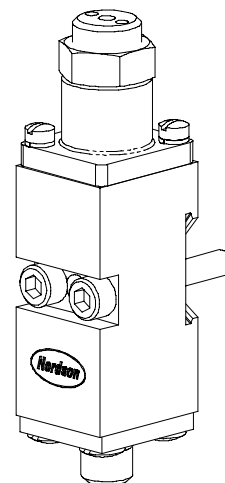

Note: It may be necessary to soak the module in R fluid (P/N 270755) in order to remove components. Refer to the manual for the proper procedure.

Continue



Service the Module

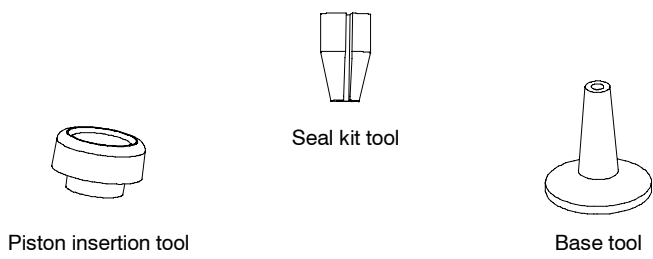

Note: Set the length of the air cap screw at 29 mm (1.14 in.) from the top of the screw to the base of the air cap (four threads showing). Set the locking nut to maintain the air cap screw position.

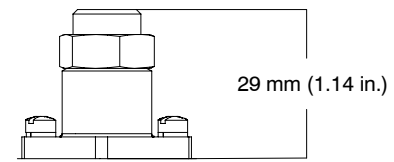

- 3.** Use the piston insertion tool to guide the piston into the module body as you push the piston down.

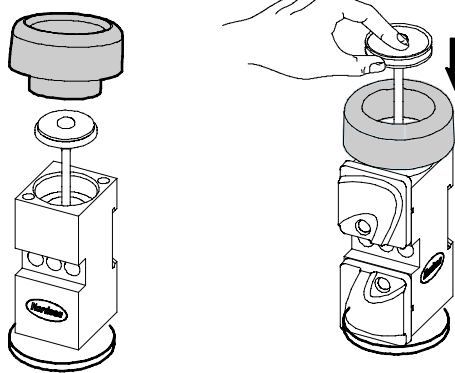

- 4.** Insert the spring into the air cap, and position the air cap onto the module body. Coat the screws with Never Seez (P/N 900341), and secure the air cap to the module. Tighten the screws to 1.7 N•m (15 in.-lb).

- 2.** Place the seal kit tool between the piston and the retaining ring. Slide the piston and needle down into the module body. Use the tool to compress the seal, seal retainer and retaining ring until the tangs on the retaining ring snap into place. Raise the piston and remove the seal kit tool.

Note: SolidBlue and SureBead needles do not have a seal retainer or a retaining ring.

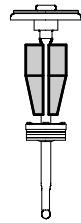

- 8.** Apply O-ring lubricant (P/N 900223) to the module body O-rings, and position them onto the grooves at the back of the module body.

Note: Air-open-spring-close modules have two O-rings. Air-open-air-close modules have three O-rings.

- 1.** Place the module body, with the pneumatic side pointing up, onto the base tool.

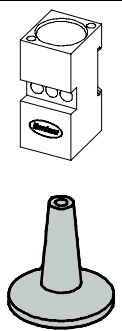

- 5.** Remove the base tool. Insert the spring seal, spring side facing the nozzle, and seal support into the hydraulic side of the module body. Insert the spring.

- 6.** Apply O-ring lubricant (P/N 900223) to the nozzle seat O-ring and install it onto the nozzle seat.

- 7.** Apply Never-Seez (P/N 900341) to the nozzle seat screws. Secure the seat to the module body. Tighten the screws to 1.7 N•m (15 in.-lb).

Continue



Install the Rebuilt Module

