

This instruction sheet provides the procedure for rebuilding a return module using a module rebuild kit. Two types of rebuild kit are available: one type includes the needle-and-piston assembly and the other does not. Refer to the module documentation for module rebuild kit part numbers.

**WARNING:** Risk of personal injury or equipment damage! Refer to the safety information provided in the melter manual before servicing the melter. Failure to comply with the safety information provided can result in personal injury, including death.

**Required Tools:**

- |                               |                       |
|-------------------------------|-----------------------|
| Hex wrenches                  | Screwdrivers          |
| 5/8-in. wrench                | Rebuild tools         |
| Multi-tool (P/N 1059671)      | Hot water or heat gun |
| Teflon paste                  | O-ring lubricant      |
| Small ruler or measuring tape |                       |

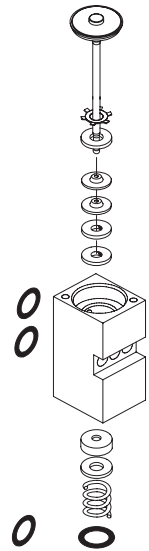

Rebuild kit components (see procedure for item identification)

**NOTE:** The rebuild kit contains parts for rebuilding any CF module. Depending on the type of module being rebuilt, some parts may be unused.

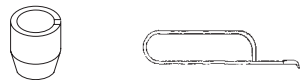

Seal tool  
P/N 272823

Retaining ring tool  
P/N 272821

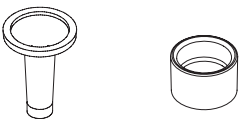

Base tool  
P/N 272824

Piston insertion tool  
P/N 1057944

**Prepare for Module Rebuild**

- To ease module removal, ensure that the applicator is heated at least to the softening point of the adhesive.
- Relieve system pressure and disable the applicator. Refer to the applicator manual as needed.

**WARNING:** Molten material! Wear eye or face protection, clothing that protects exposed skin, and heat-protective gloves when servicing equipment that contains molten hot melt. Even when solidified, hot melt can still cause burns. Failure to wear appropriate personal protective equipment can result in personal injury.

- Remove the module from the applicator, then remove the nozzle from the module. Refer to the module documentation as needed.

**Disassemble the Module**

- Remove and discard the module O-rings (9).
- Remove the air cap assembly (2) from the top of the module. The large compression spring (3) may fall out when you remove the assembly.

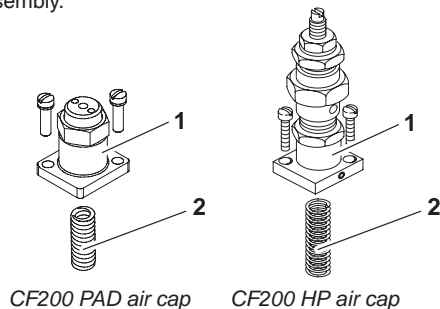

**Disassemble the Module (contd.)**

- Remove the seat (14) and then remove the O-ring (15) from the seat. Discard the O-ring.
- Remove the small compression spring (12) and lower seal support disk (11) from the bottom of the module body. You may need to use the retaining ring removal tool (or a similar tool).
- Remove the needle-and-piston assembly (1) from the top of the module body.
- Use the retaining ring removal tool (or a similar tool) to remove the retaining ring (3) from the module body.

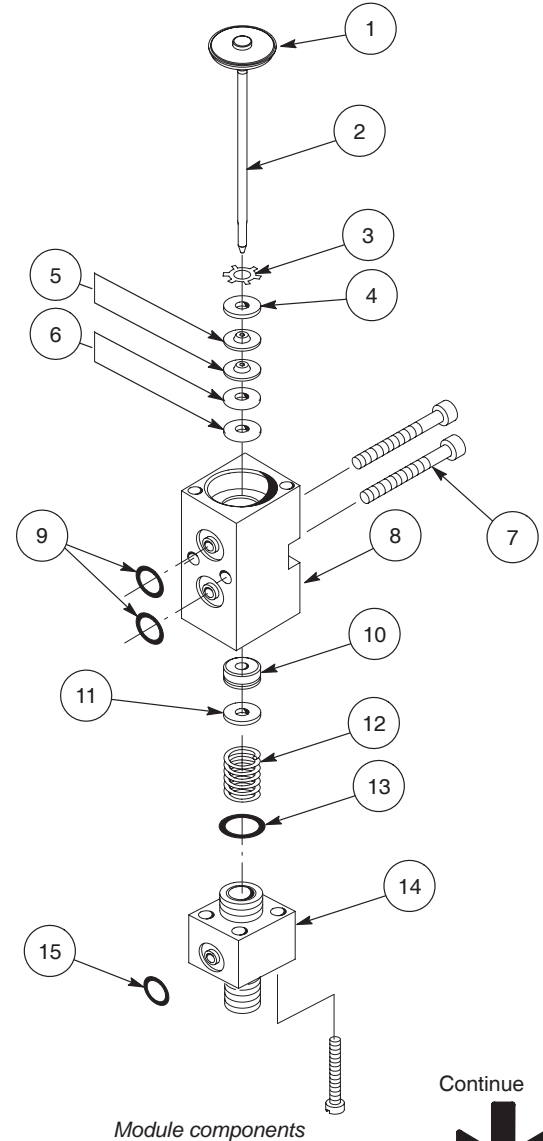

Continue



## Disassemble the Module (contd.)

**CAUTION:** Risk of equipment damage. Do not scrape the inside of the module body when using a tool to remove the spring seal.

- Remove the spring seal by turning the module body over and using the retaining ring removal tool (or a similar tool).

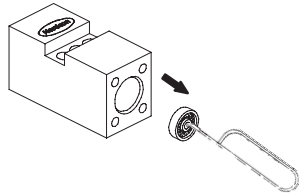

The module is now fully disassembled. Discard any components that will be replaced, clean existing components as needed, and have all new components ready for module assembly.

**CAUTION:** Risk of equipment damage. When cleaning the module body, do not bake or sand blast—this will damage the seal mating surfaces.

## Assemble the Upper Module Components

**CAUTION:** Do not change the module configuration during reassembly. Substitution of O-rings or seals from other manufacturers, or the combination of a new seal with a badly worn needle, can cause adhesive to leak into the pneumatic section or out from the front of the module.

- Place the module body (1), with the pneumatic section pointing upward, on the base tool (2) supplied with the rebuild kit.

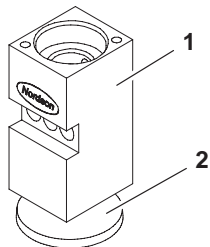

## Assemble the Upper Module Components (contd.)

- Use a heat gun or hot plate to warm the hat seals to approximately 93 °C (200 °F) to soften them. Use tweezers to handle the hat seals after softening them.

- Assemble the following onto the needle-and-piston assembly:

- seal tool (1)
- retaining ring with tangs down (2)
- upper seal support disk (3)
- two hat seals pointing toward the piston tool (4)
- two hat seals pointing away from the piston tool (5)

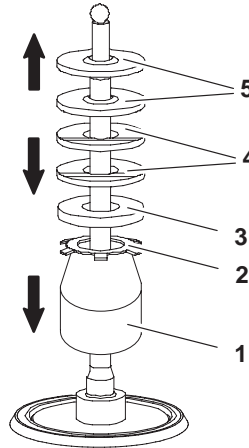

- Position the piston insertion tool (3) on top of the module body.

- Slide the needle-and-piston assembly components through the piston insertion tool into the module body. By pressing down on the center of the piston, use the seal tool (1) to compress the retaining ring, seal support disk, and hat seals (2) until the tangs on the retaining ring snap into place.

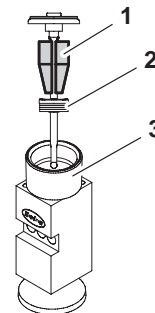

## Assemble the Upper Module Components (contd.)

**CAUTION:** Risk of equipment damage. When pulling the needle-and-piston assembly out of the module body, be careful not to damage or deform the piston seal.

- Remove the piston insertion tool and lift the module off the base tool—the needle will be protruding from the bottom of the module. Hold the module body and push the needle against the table top or work surface. The needle assembly will come out enough so that it can be grasped with two fingers and pulled from the module body.

- Remove the seal tool from the needle.

- Place the module body back on the base tool (3), position the piston insertion tool (2) on top of the module, and stabilize the module on a flat surface (such as a block or table).

- Push the needle-and-piston assembly (1) through the piston insertion tool into the module body.

- Use another base tool (1, or a similar tool, such as a socket or nut driver) to push the needle-and-piston assembly through the seals and into the bore of the module body until the needle seats.

- Remove the piston insertion (2) and base tools.

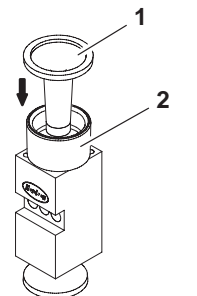
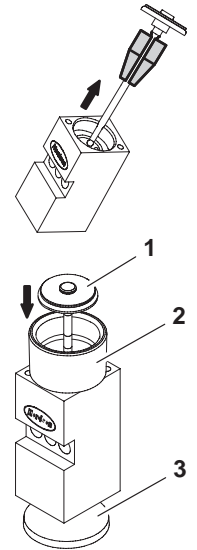

Continue



## Assemble the Lower Module Components

1. Insert the following in the bottom of the module body:
  - spring seal (1) with the spring side pointing up (towards the bottom of the module)
  - lower seal support disk (2)

You may need to use the base tool to push the seal and washer into place.

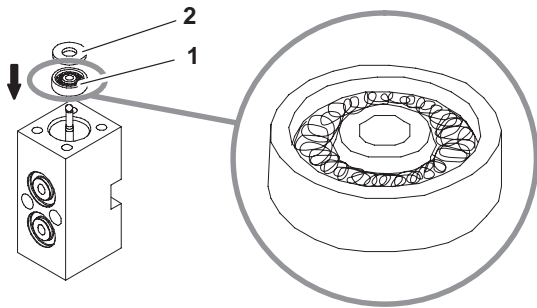

2. Coat the seat O-ring (3) with O-ring lubricant and install it on the seat (2).
3. Coat the seat screws (1) with Teflon paste.
4. Insert the small compression spring (4) inside the module body and then install the seat to compress and secure the spring. Alternate tightening of the seat screws to 1.8–2.0 N•m (16–18 in.-lb).

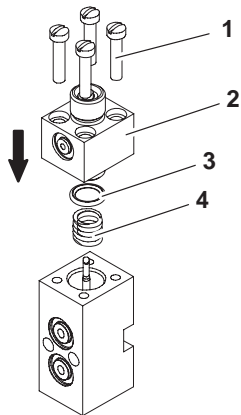

## Install the Air Cap

1. Position the air cap assembly (2) and large compression spring (3) on the module body. Coat the air cap screws (1) with Teflon paste and use them to secure the air cap to the module body. Tighten the screws to 1.5–1.7 N•m (13–15 in.-lb).

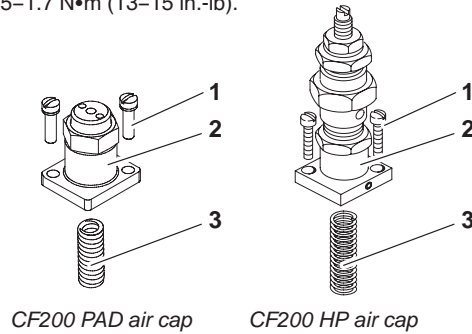

2. To adjust the loading screw on a **CF200 PAD** module, loosen the locking nut (2) at the top of the module and hold it loosely in place with a  $\frac{5}{8}$ -in wrench while turning the loading screw (1) with the multi-tool. Adjust the loading screw until it is 24 mm (0.94 in.) from the top of the loading screw to the base of the air cap. Tighten the locking nut to maintain the screw position.

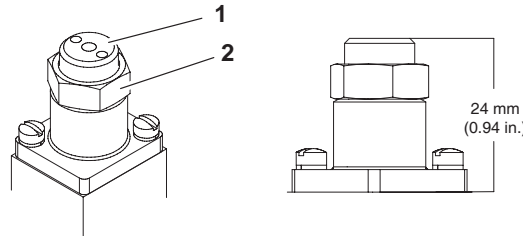

3. To set the loading screw on a **CF200 HP** module to the factory setting, loosen the locking nut (2), turn the loading screw (1) clockwise until it bottoms out, back the loading screw out three full turns (counterclockwise), and tighten the locking nut. To use the loading screw to adjust adhesive output, refer to *Synchronizing Multi-Module Applicator Adhesive Output* earlier in this section.

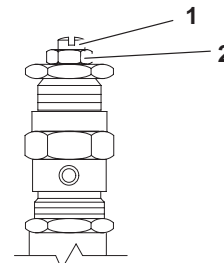

## Restore the System to Normal Operation

1. Coat new module O-rings with O-ring lubricant and place them in the O-ring bores on the back of the module.

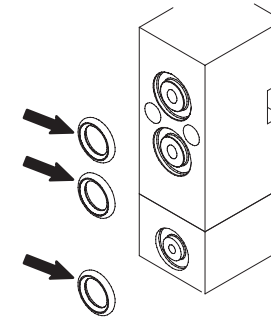

2. Reinstall the module. Refer to the module documentation as needed.
3. Reinstall the nozzle. Refer to the module documentation as needed.
4. Restore the system to normal operation.